

# PPC-175T

## 17" Panel PC with Intel® Pentium®/ Celeron® M Processor



### Features

- 17" TFT SXGA LCD
- Intel® Pentium®/Celeron® M up to 1.8 GB/1.5 GB
- System memory up to 2 GB DDR RAM
- Built-in CF card interface (IDE interface for OS booting)
- One PCI expansion slot
- Two 10/100 Mbps Ethernet ports; Two IEEE 1394 ports
- Resistive, capacitive, SAW, infrared type, and projected capacitive touch screens are available
- Light sensor supports automatic backlight control



### Introduction

The PPC-175T is an Intel Pentium/Celeron M based Panel PC with 17" color TFT LCD (resolution up to 1280 x 1024). It features multimedia devices, various connectors, and can be installed in virtually any application. In addition, its user-friendly interface makes it a great host for information appliances. Three serial ports and two 10/100 Mbps Ethernet ports give the PPC-175T advanced networking capabilities, and provide a great solution for versatile applications.

### Specifications

Processor System	CPU	Supports Socket 478 based Pentium /Celeron M up to 1.8 GHz/ 1.5 GHz				
	Disk Drive Housing	Room for 1 x 2.5" HDD, SATA interface is available, but converter board needed				
	Dimensions (W x H x D)	442 x 362 x 111.5 mm (17.4" x 14.25" x 4.39")				
	Front Panel Protection	IP65/NEMA 4 compliant (not for SAW model)				
	HDD	IDE HDD interface (2.5" HDD bay)				
	CD-ROM Drive	Optional 24X or above				
	DVD+/-RW Drive	Optional 8X or above				
	Combo Drive	Optional DVD/CD-RW 8D/24W/24E/24R or above				
	Memory	Supports up to 2 GB DDR SDRAM (184-pin)				
	FDD	Optional				
	Network (LAN)	2 x ports 10/100 Mbps Ethernet interface				
I/O Ports		- 3 x COM ports: 2 x RS-232, 1 x RS-232/422/485			- 1 x PS/2 mouse and keyboard interface	
		- 4 x USB 2.0 ports			- Mic-in, Line-in, Line-out	
		- 1 x PCMCIA Type II			- 2 x IEEE 1394 ports	
Bus Expansion		1 x PCI expansion slot, 1 x Mini PCI card				
	Operating Temperature	0 ~ 50° C (32 ~ 122° F)				
	Relative Humidity	5% ~ 85% non-condensing				
	Shock	10 G peak acceleration (11 msec. duration)				
	EMC	BSMI, VCCI, CE, FCC Class B, CCC				
Safety	CB, CE, UL					
Power Supply	Output Rating	100 W (max.)				
	Input Voltage	100 ~ 250 V <sub>DC</sub> @ 50 ~ 60 Hz				
	Output Voltage	+3.3 V @ 8.0 A, +5 V @ 12.0 A, +12 V @ 4.0 A, -12 V @ 0.2 A, +5 Vsb @ 2.0 A				
LCD Display	Display Type	Color TFT LCD				
	Size (Diagonal)	17"				
	Max. Resolution	1280 x 1024				
	Max. Colors or Grayscales	16.7 M				
	Pixel Pitch (mm)	0.264 x 0.264				
	Luminance (cd/m <sup>2</sup> )	300				
	Contrast Ratio	800 : 1				
	Viewing Angle	80° (left), 80° (right), 80° (up), 80° (down)				
	Operating Temperature	0 ~ 50° C				
	VR Controls	Brightness				
	Simultaneous Mode	Yes				
LCD MTBF	50,000 hrs					
Touchscreen (Optional)	Types	Analog Resistive	Capacitive	Surface Acoustic Wave	Infrared	Projected Capacitive
	Resolution	Continuous	1024 x 1024	4096 x 4096	4096 x 4096	1024 x 768
	Light Transmission	80%	91.5%	91%	91%	91%
	Controller	RS-232 Interface	RS-232 Interface	RS-232 Interface	RS-232 Interface	RS-232 Interface
	Power Consumption	+5 V @ 200 mA	+5 V @ 100 mA	+5 V @ 150 mA	+5 V @ 150 mA	+5 V @ 100 mA
	Software Driver	Supports both DOS and Windows				Supports Windows only
	Durability (Touches)	35 million	225 million	50 million	100,000 hrs	Unlimited

## Dimensions

Unit: mm (inch)

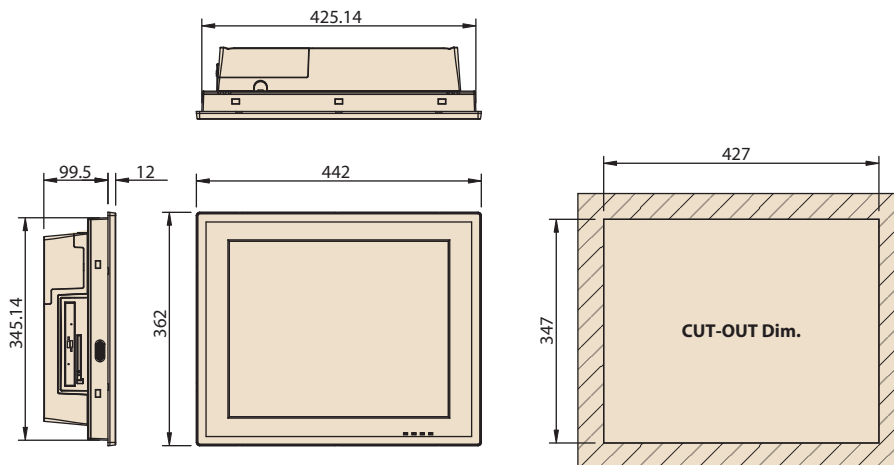

## Ordering Information

Part No.	Description
PPC-FP-A01E	USB Fingerprint Accessory Kit
PPC-ARM-A03	VESA Standard ARM for PPC series
PPC-155 STAND	Stand kit for PPC-154/155/174/175T Series
PPC-174 WL-MT	Wall mount kit for PPC-154/155/175T Series
PPC-175T-BARE-VE	PPC-175T Bare BOM with infrared touchscreen
PPC-175T-BARE-TE	PPC-175T Bare BOM with resistive touchscreen
PPC-175T-BARE-SE	PPC-175T Bare BOM with SAW touchscreen
PPC-175T-BARE-PE	PPC-175T Bare BOM with projected capacitive touchscreen
PPC-175T-BAREE	Panel PC with 17" color TFT LCD display (resolution 1280 x 1024)
PPC-175T-BARE-CE	PPC-175T Bare BOM with capacitive touchscreen
1702002605	POWER CABLE 90D 220V EUROPEAN 250V/6A 1.8M
1702002600	POWER Cable UL/CSA (USA) 180D 125V10A 1.83M
9898007100E	2.5" PATA to SATA HDD Converter Board
989KP15505E	Optical Disc Drive Bracket for PPC-155/175 (Bracket only, W/O ODD)
989KP15504E	Mini-PCI [Realtek] 802.1b/g Wireless Module for PPC-155/175
989KP15503E	Mini-PCI [VIA] 802.1b/g Wireless Module for PPC-155/175
989KP15502E	DVD-RW Module of PPC-155/175
989KP15501E	Combo Module of PPC-155/175
989KP15500E	CD-ROM Module of PPC-155/175

## Feature Details

### Protection

To meet the requirements of a public environment, the front panel PPC-175T complies with the IP65/NEMA 4 protection standard. Furthermore, the watchdog timer and power management features make the system secure and stable. The onboard hardware monitoring feature provides an automatic protection function, which prevents the CPU from becoming overheated.

### Expansion

To extend functionality, the PPC-175T is designed with one expansion slot for PCI cards, four USB 2.0 (Universal Serial Bus) ports, and one PCMCIA card bus (Type II x 1). With these expansion capabilities, the PPC-175T not only functions as an HMI, but also as a computing center on which to build your applications.

### Easy Maintenance

Maintaining and replacing the LCD and touchscreen are made easier through the PPC-175T modular design. In order to replace a defective LCD or touchscreen, one merely needs to remove the front cover and LCD bracket instead of disassembling the whole system.

### Touchscreen Options

Customers can choose from five optional types of standardized touchscreens: resistive, capacitive, infrared, SAW (Surface Acoustic Wave), and projected capacitive. Flexible options for the PPC-175T offer a more user-friendly interface for diverse environments.

## Fully Integrated I/O

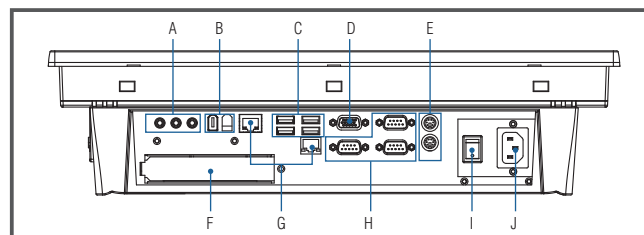

- A. Line-in / Line-out / Mic-in
- B. IEEE 1394 x 2
- C. USB 2.0 x 4
- D. VGA port
- E. PS/2 mouse & keyboard
- F. PCI slot x 1
- G. 10/100 Base-T Ethernet x 2
- H. RS-232 x 2, RS-232/422/485 x 1
- I. Power switch
- J. AC Inlet

Компания «Life Electronics» занимается поставками электронных компонентов импортного и отечественного производства от производителей и со складов крупных дистрибьюторов Европы, Америки и Азии.

С конца 2013 года компания активно расширяет линейку поставок компонентов по направлению коаксиальный кабель, кварцевые генераторы и конденсаторы (керамические, пленочные, электролитические), за счёт заключения дистрибьюторских договоров

Мы предлагаем:

- Конкурентоспособные цены и скидки постоянным клиентам.
- Специальные условия для постоянных клиентов.
- Подбор аналогов.
- Поставку компонентов в любых объемах, удовлетворяющих вашим потребностям.
- Приемлемые сроки поставки, возможна ускоренная поставка.
- Доставку товара в любую точку России и стран СНГ.
- Комплексную поставку.
- Работу по проектам и поставку образцов.
- Формирование склада под заказчика.
- Сертификаты соответствия на поставляемую продукцию (по желанию клиента).
- Тестирование поставляемой продукции.
- Поставку компонентов, требующих военную и космическую приемку.
- Входной контроль качества.
- Наличие сертификата ISO.

В составе нашей компании организован Конструкторский отдел, призванный помогать разработчикам, и инженерам.

Конструкторский отдел помогает осуществить:

- Регистрацию проекта у производителя компонентов.
- Техническую поддержку проекта.
- Защиту от снятия компонента с производства.
- Оценку стоимости проекта по компонентам.
- Изготовление тестовой платы монтаж и пусконаладочные работы.



Тел: +7 (812) 336 43 04 (многоканальный)

Email: [org@lifeelectronics.ru](mailto:org@lifeelectronics.ru)