

# Shenzhen Leadtek Technology Co.,Ltd

- Preliminary Specification  
 Approval Specification

## SPECIFICATION FOR LCD MODULE

Customer : \_\_\_\_\_  
Product Model: LTK080A60A004T  
Sample code: \_\_\_\_\_

Designed by	Checked by	Approved by

### Final Approval by Customer

Approved by	Comment

※The specification of "TBD" should refer to the measured value of sample . If there is difference between the design specification and measured value, we naturally shall negotiate and agree to solution with customer.

**Revision History**

Version	Contents	Date	Note
A0	Original	2017.06.20	

## Contents

No.	Item	Page
1	Features	4
2	General Specifications	4
3	Outline Dimension	5
4	Electrical Specifications	7
5	Optical Specifications	17
6	Reliability Test	20
7	Handling Precautions	21
8	Precaution for use	22
9	Package Drawing	23
10	Label Drawing	24
11	HSF Requirements	24
12	Scope	24
13	Numbering System	25

## 1. Features

This module is a color active matrix TFT-LCD (Thin Film Transistor Liquid Crystal Display) module that uses amorphous silicon TFT as a switching device. This module is composed of LCD panel, driver IC, and LED backlight.

## 2. General Specifications

No.	Item	Specification
1	LCD size	8.0 inch
2	Resolution	1200 (RGB)X1920
3	Display mode	Normally black
4	Pixel pitch	0.0897 (W) X 0.0897 (H) mm
5	Active area	107.64(W)X172.22(H) mm
6	Module size	132.6(W)X193.6(H)X3.6(D)mm
7	Pixel arrangement	RGB Vertical stripe
8	Interface	MIPI(4lane)
9	Backlight power consumption	1.4W (typ.)
10	Panel power consumption	TBD (typ.)
11	Weight	73g (typ.)
12	Luminance for LCM (不帶 TP)	400cd/m <sup>2</sup> (typ.)

# 3.Outline Dimension

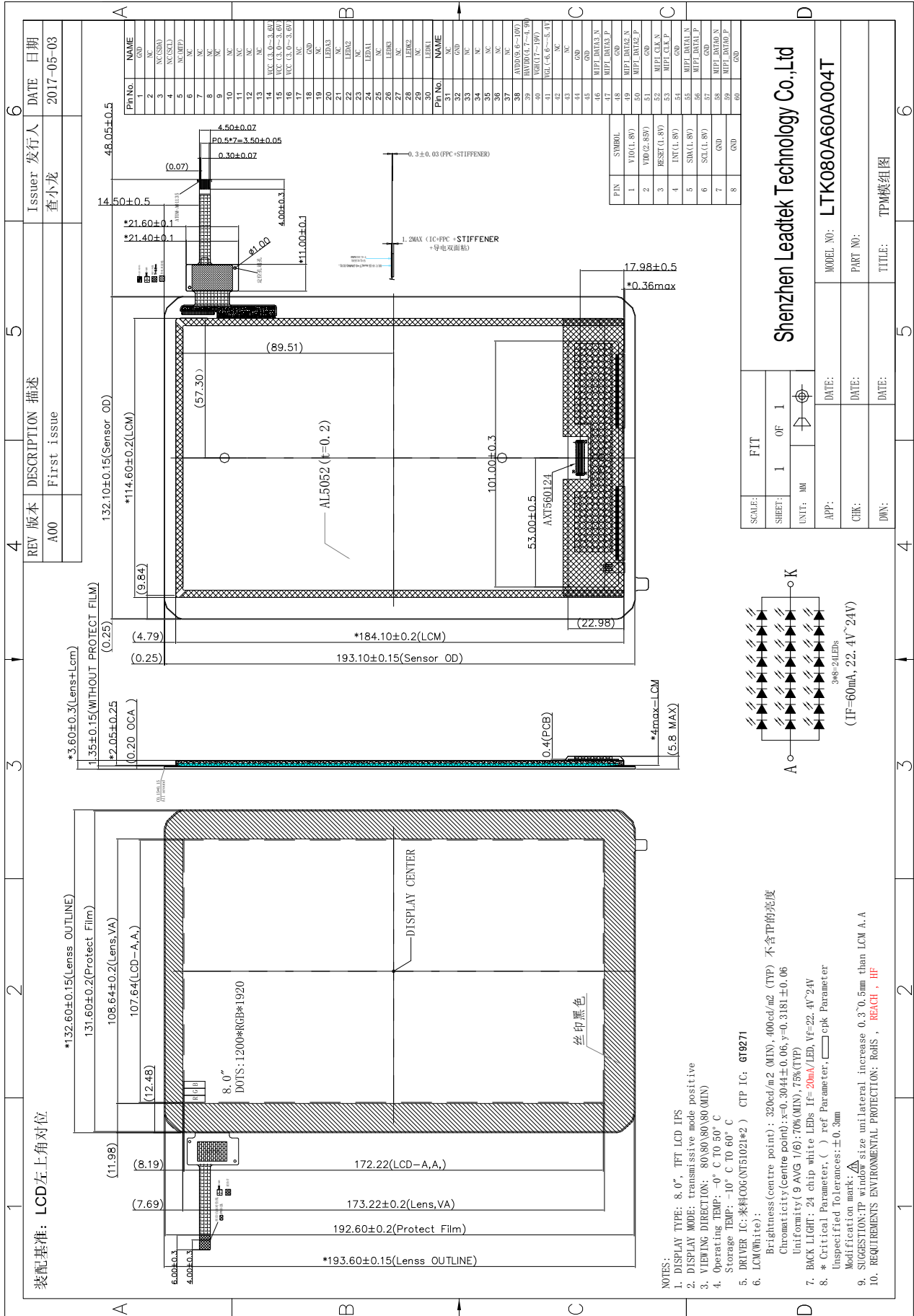

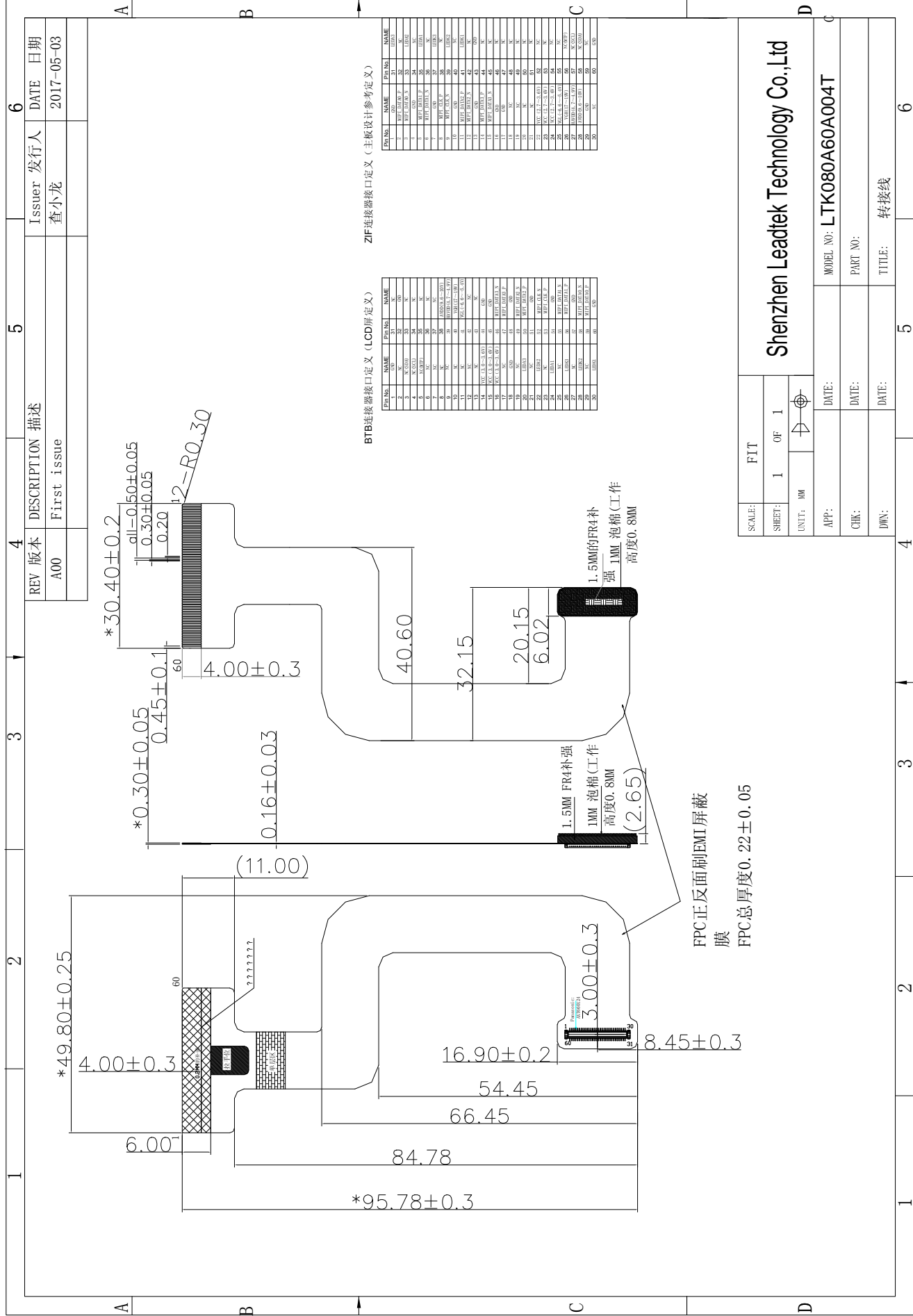

BTB连接器接口定义 (LCD屏定义)

Pin No.	NAME	Pin No.	NAME
1	NC	31	NC
2	NC	32	NC
3	NC	33	NC
4	NC	34	NC
5	NC	35	NC
6	NC	36	NC
7	NC	37	NC
8	NC	38	NC
9	NC	39	NC
10	NC	40	NC
11	NC	41	NC
12	NC	42	NC
13	NC	43	NC
14	NC	44	NC
15	NC	45	NC
16	NC	46	NC
17	NC	47	NC
18	NC	48	NC
19	NC	49	NC
20	NC	50	NC
21	NC	51	NC
22	NC	52	NC
23	NC	53	NC
24	NC	54	NC
25	NC	55	NC
26	NC	56	NC
27	NC	57	NC
28	NC	58	NC
29	NC	59	NC
30	NC	60	NC

ZIF连接器接口定义 (主板设计参考定义)

Pin No.	NAME	Pin No.	NAME
1	NC	31	NC
2	NC	32	NC
3	NC	33	NC
4	NC	34	NC
5	NC	35	NC
6	NC	36	NC
7	NC	37	NC
8	NC	38	NC
9	NC	39	NC
10	NC	40	NC
11	NC	41	NC
12	NC	42	NC
13	NC	43	NC
14	NC	44	NC
15	NC	45	NC
16	NC	46	NC
17	NC	47	NC
18	NC	48	NC
19	NC	49	NC
20	NC	50	NC
21	NC	51	NC
22	NC	52	NC
23	NC	53	NC
24	NC	54	NC
25	NC	55	NC
26	NC	56	NC
27	NC	57	NC
28	NC	58	NC
29	NC	59	NC
30	NC	60	NC

SCALE: FIT  
 SHEET: 1 OF 1  
 UNIT: MM

DATE: DATE: DATE:  
 MODEL NO: LTK080A60A004T  
 PART NO:  
 TITLE: 转接线

1.5MM FR4补强  
 1MM 泡棉(工作高度0.8MM)  
 1.5MM的FR4补强  
 1MM 泡棉(工作高度0.8MM)  
 (2.65)  
 FPC正反面刷EMI屏蔽膜  
 FPC总厚度0.22±0.05

## 4. Electrical specifications

### 4.1 Block Diagram

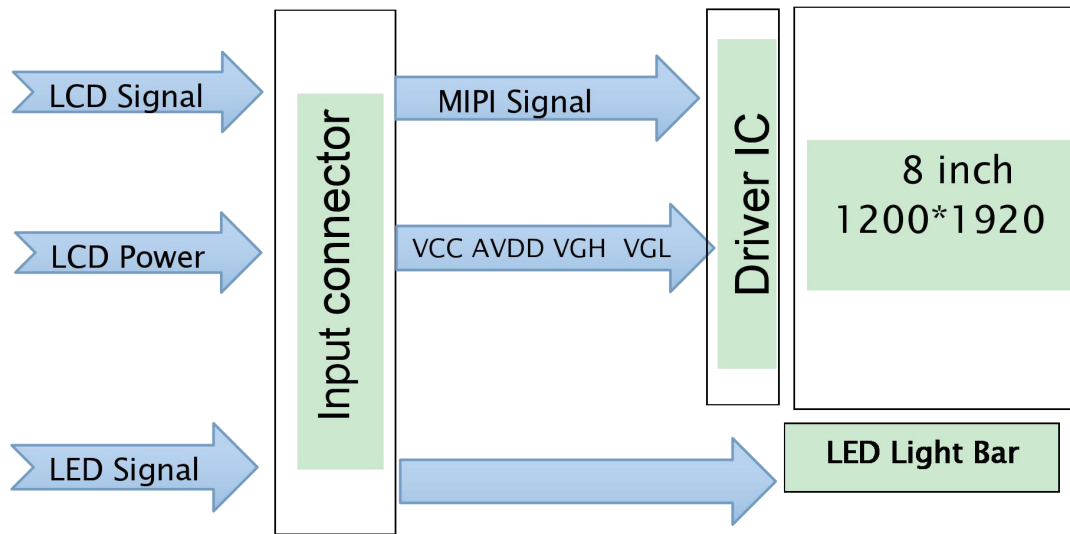

## 4.2 Interface Definition

Pin No.	Symbol	Function
1	GND	Power Ground
2	NC	No connection
3	NC(SDA)	No connection
4	NC(SCL)	No connection
5	NC(MTP)	No connection
6	NC	No connection
7	NC	No connection
8	NC	No connection
9	NC	No connection
10	NC	No connection
11	NC	No connection
12	NC	No connection
13	NC	No connection
14	VCC	Power supply
15	VCC	Power supply
16	VCC	Power supply
17	NC	No connection
18	GND	Power Ground
19	NC	No connection
20	LEDA3	LED Anode
21	NC	No connection
22	LEDA2	LED Anode
23	NC	No connection
24	LEDA1	LED Anode
25	NC	No connection
26	LEDK3	LED Cathode
27	NC	No connection
28	LEDK2	LED Cathode
29	NC	No connection
30	LEDK1	LED Cathode
31	NC	No connection



32	GND	Power Ground
33	NC	No connection
34	NC	No connection
35	NC	No connection
36	NC	No connection
37	NC	No connection
38	AVDD	Power for Analog Circuit
39	HAVDD(NC)	No connection
40	VGH	Gate ON Voltage
41	VGL	Gate OFF Voltage
42	NC	No connection
43	NC	No connection
44	GND	Power Ground
45	GND	Power Ground
46	MIPI_DATA3_N	MIPI data pair 3 negative signal
47	MIPI_DATA3_P	MIPI data pair 3 positive signal
48	GND	Power Ground
49	MIPI_DATA2_N	MIPI data pair 2 negative signal
50	MIPI_DATA2_P	MIPI data pair 2 positive signal
51	GND	Power Ground
52	MIPI_CLK_N	MIPI CLK negative signal
53	MIPI_CLK_P	MIPI CLK positive signal
54	GND	Power Ground
55	MIPI_DATA1_N	MIPI data pair 1 negative signal
56	MIPI_DATA1_P	MIPI data pair 1 positive signal
57	GND	Power Ground
58	MIPI_DATA0_N	MIPI data pair 0 negative signal
59	MIPI_DATA0_P	MIPI data pair 0 positive signal
60	GND	Power Ground

Note1:

LCD CONNECTOR AXT560124(Panasonic)

### 4.3 Absolute Max. Rating

Item	Symbol	Values		Unit
		Min.	Max.	
Power Voltage	VCC	-0.5	5	V
	AVDD	9.6	10	V
	VGH	-0.3	32	V
	VGL	-16	0.3	V
Backlight forward current	I <sub>LED</sub>	0	20	mA(For each LED)
Input Signal Voltage	V <sub>I</sub>	-0.3	VCC+0.3	V
Operation Temperature	T <sub>OP</sub>	0	50	°C
Storage Temperature	T <sub>ST</sub>	-10	60	°C

Note: The absolute maximum rating values of this product not allowed to be exceeded at any times. Should be module be used with any of absolute maximum ratings exceeded. The characteristics of the module may not be recovered, or in an extreme case, the module may be permanently destroyed.

### 4.4 Typical Operation Conditions

Item	Symbol	Values			Unit	Note
		Min.	Typ.	Max.		
Power Voltage	VCC	3.0	3.3	3.6	V	
	AVDD	9.6	9.8	10	V	
	VGH	17	18	19	V	
	VGL	-6.6	-6	-5.4	V	
Power consumption	I <sub>VCC</sub>	-	TBD	-	mA	
	I <sub>AVDD</sub>	-	TBD	-	mA	
	I <sub>VGH</sub>	-	TBD	-	mA	
	I <sub>VGL</sub>	-	TBD	-	mA	

### 4.5 LED Backlight Specification

Item	Symbol	Condition	Min	Typ	Max	Unit
Forward Voltage	V <sub>f</sub>	I <sub>f</sub> =60mA	22.4	-	24	V

LED circuit:

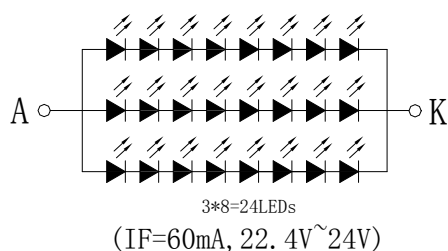

## 4.6 Power On/Off Sequence

To prevent the device damage from latch up, the power on/off sequence shown below must be followed.

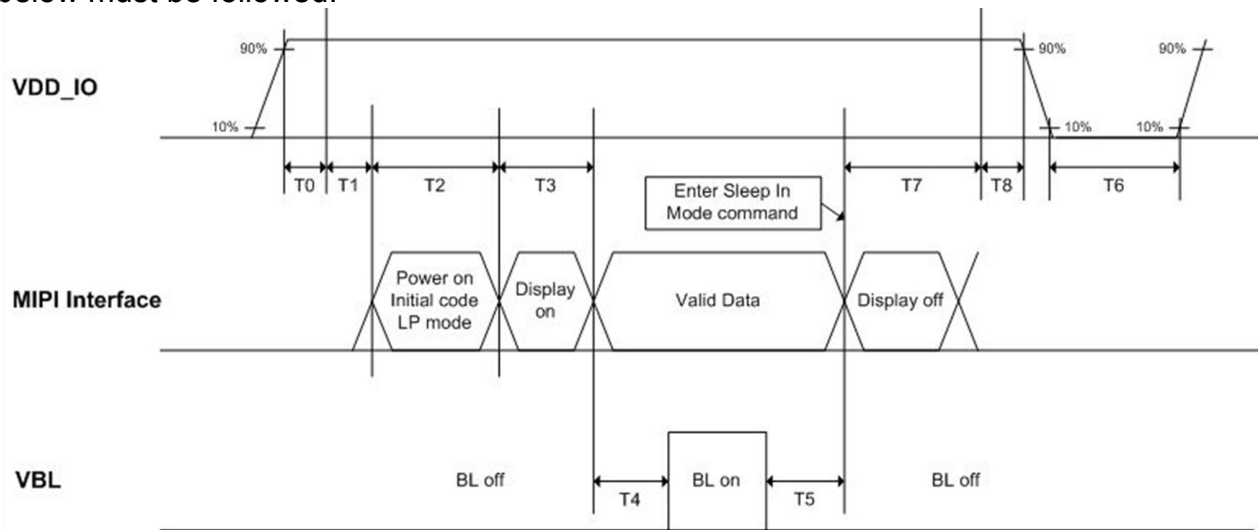

	Min.	Typ.	Max.	Unit
T0 +T1	30	-		ms
T2	50	-		ms
T3	-	0	-	ms
T4	100	-	-	ms
T5	50	-	-	ms
T6	500	-	-	ms
T7	100	-	-	ms
T8	0	-	-	ms

## 4.6.1 Power On Sequence

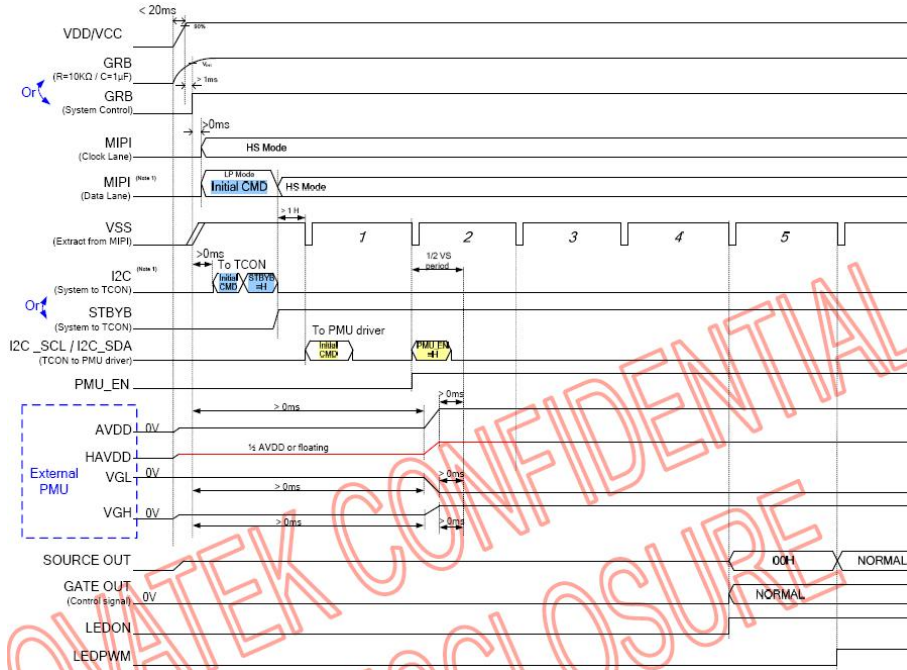

## 4.6.2 Power Off Sequence

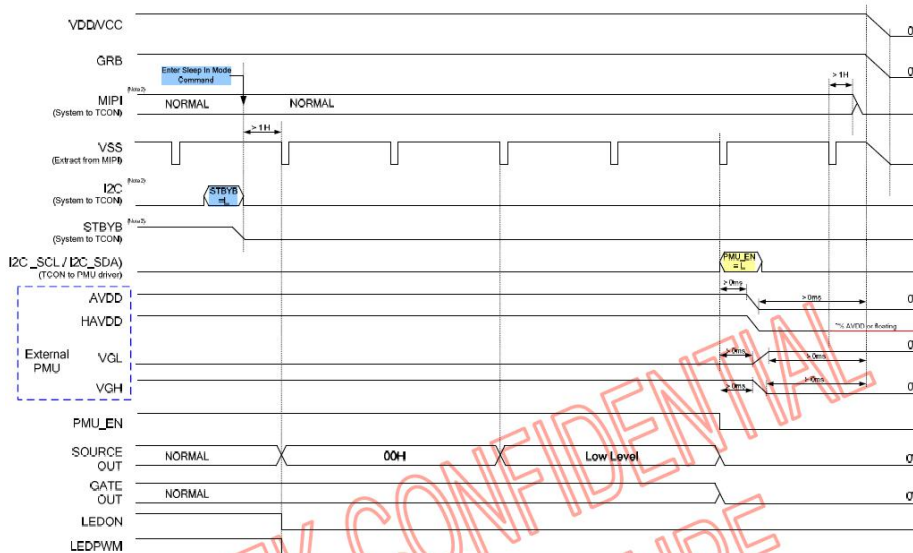

## 4.7 Data input format

### 4.7.1 Data input Format for MIPI

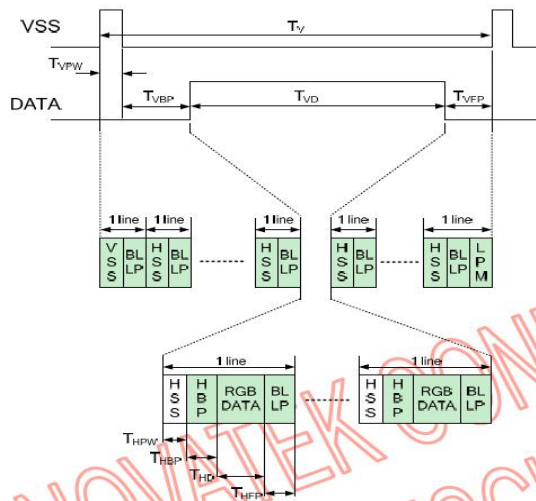

## 4.7.2 Input Timing Table

ITEM		SYMBOL	min	typ	max	UNIT	
LCD	Frame Rate	-	55	60		Hz	
	Pixels Rate	-		159.4		MHz	
Timing	DCLK	Frequency	fCLK		500	MHz	
		Period	Tclk	1		ns	
	Horizontal	Horizontal total time	tHP	1275	1341	1342	tCLK
		Horizontal Active time	tHadr	1200			tCLK
		Horizontal Pulse Width	tHsync	1	1	1	tCLK
		Horizontal Back Porch	tHBP	32	60	60	tCLK
		Horizontal Front Porch	tHFP	60	80	81	tCLK
	Vertical	Vertical total time	tvp	1981	1981	1982	tH
		Vertical Active time	tVadr	1920			tH
		Vertical Pulse Width	tVsync	1	1	1	tH
Vertical Back Porch		tVBP	25	25	25	tH	
Vertical Front Porch		tVFP	35	35	36	tH	
Differential Swing		VDswing	140			mV	
Bit Rate		TX SPD (Mbps)	955	999	1000	Mbps	
Pixel Format				8		Data bit/ pixel	
Lane				1		Lane	

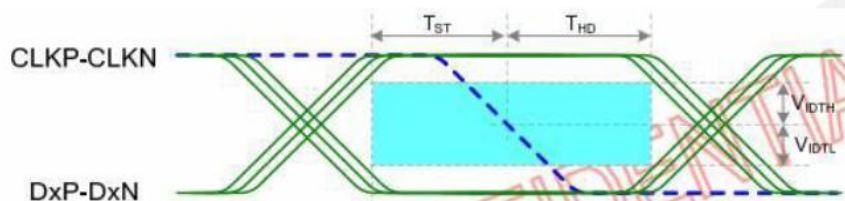
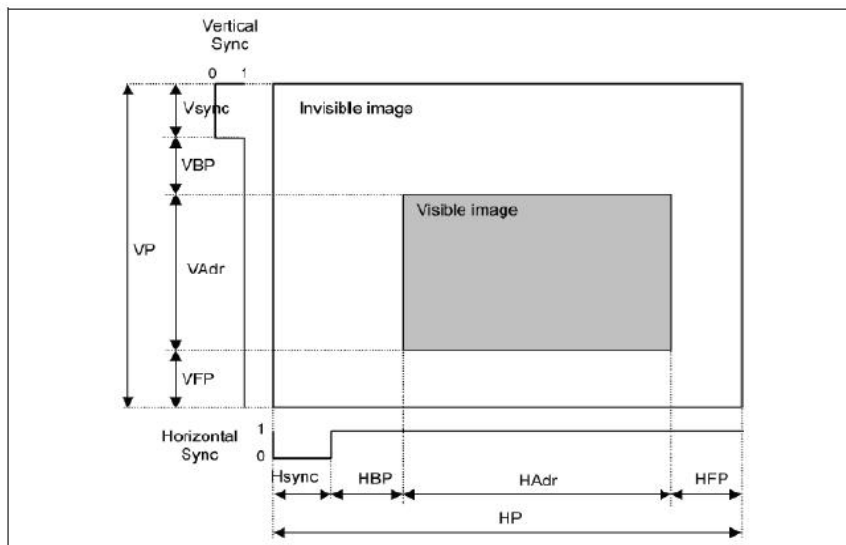

**Note:** VIDTH is the input high threshold and should  $>70mV$

VIDTL is the input low threshold and should  $<-70mV$

## 4.8 MIPI Interface Characteristic

### 4.8.1 MIPI DC Characteristic

(VCC=VCC\_IF=1.55V to 1.65V, VDD= 2.7V to 3.6V, AVDD= 7V to 10V, GND=AGND= 0V, TA= -20 to +85°C)

Parameter	Symbol	Min.	Typ.	Max.	Unit	Condition
MIPI digital operation current	$I_{VCCIF}$	-	-	24	mA	VCC=VCC_IF=1.6V, Data Rate=500Mbps, Input pattern: 55h→AAh→55h→AAh
MIPI digital stand-by current	$I_{VCCIFST}$	-	200	-	uA	VCC_IF input current. All input signal are stopped.
<b>MIPI Characteristics for High Speed Receiver</b>						
Single-ended input low voltage	$V_{ILHS}$	-40	-	-	mV	
Single-ended input high voltage	$V_{IHHS}$	-	-	460	mV	
Common-mode voltage	$V_{CMRXDC}$	155	-	330	mV	
Differential input impedance	$Z_{ID}$	80	100	125	ohm	
Differential input high threshold	$V_{IDTH}$	-	-	70	mV	
Differential input low threshold	$V_{IDTL}$	-70	-	-	mV	
<b>MIPI Characteristics for Low Power Mode</b>						
Pad signal voltage range	$V_I$	-50	-	1350	mV	
Ground shift	$V_{GNDSH}$	-50	-	50	mV	
Input low level	$V_{IL}$	-150	-	150	mV	
Input high level	$V_{IH}$	1.1	1.2	1.3	V	

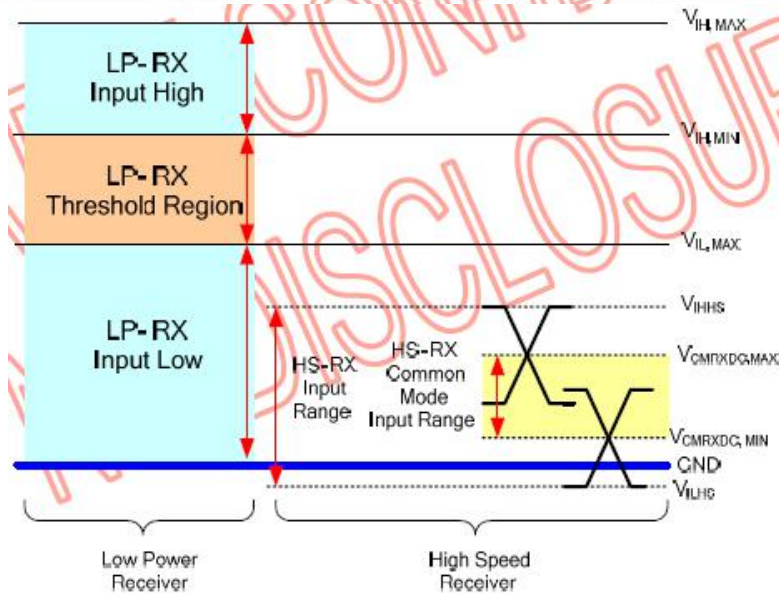

### 4.8.2 MIPI AC Characteristic

#### A.LP Transmitter AC Specification

(VCC=VCC\_IF=1.55V to 1.65V, VDD= 2.7V to 3.6V, AVDD= 7V to 10V, GND=AGND= 0V, TA= -20 to +85°C)

Parameter	Symbol	Min	Typ	Max	Units
15%-85% rise time and fall time	$T_{RLP} / T_{FLP}$	-	-	25	ns
Pulse width of the LP exclusive-OR clock	$T_{LP-PULSE-TX}$	50	-	-	ns
Period of the LP exclusive-OR clock	$T_{LP-PER-TX}$	100	-	-	ns

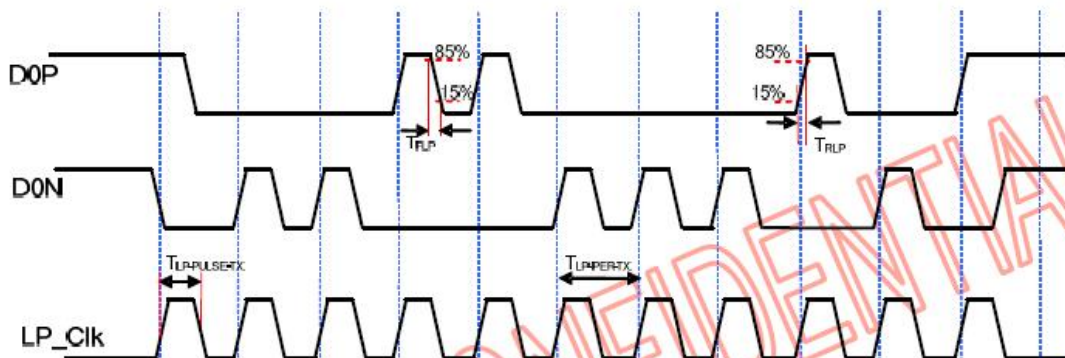



## B.High Speed Transmission

### a. Data-clock Timing Specifications

(VCC=VCC\_IF=1.55V to 1.65V, VDD= 2.7V to 3.6V, AVDD= 7V to 10V, GND=AGND= 0V, TA= -20 to +85°C)

Parameter	Symbol	Min	Typ	Max	Units
UI instantaneous	UI <sub>INST</sub>	1.0	-	12.5	ns
Data to Clock Setup Time	T <sub>SETUP</sub>	0.25	-	-	UI <sub>INST</sub>
Data to Clock Hold Time	T <sub>HOLD</sub>	0.25	-	-	UI <sub>INST</sub>

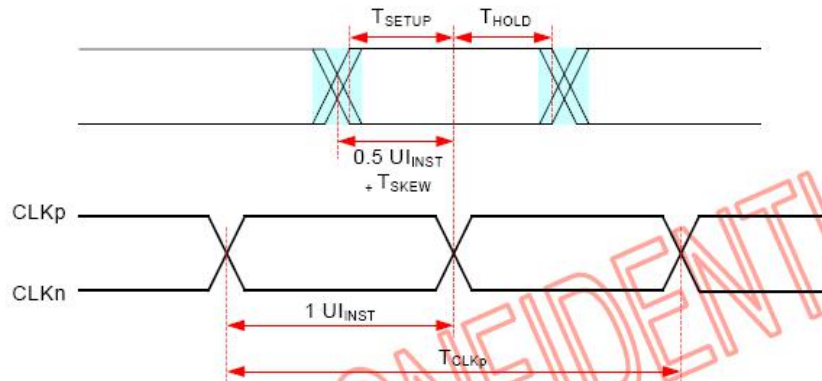

### b. High Speed Data Transmission in Bursts

(VCC=VCC\_IF=1.55V to 1.65V, VDD= 2.7V to 3.6V, AVDD= 7V to 10V, GND=AGND= 0V, TA= -20 to +85°C)

Parameter	Symbol	Min	Typ	Max	Units
Time to drive LP-00 to prepare for HS transmission	T <sub>HS-PREPARE</sub>	40+4UI	-	85+6UI	ns
Time from start of T <sub>HS-TRAIL</sub> or T <sub>CLK-TRAIL</sub> period to start of LP-11 state	T <sub>EOT</sub>	-	-	105+12UI	ns
Time to enable Data Lane receiver line termination measured from when Dn cross V <sub>IL,MAX</sub>	T <sub>HS-TERM-EN</sub>	-	-	35+4UI	ns
Time to drive flipped differential state after last payload data bit of a HS transmission burst	T <sub>HS-TRAIL</sub>	60+4UI	-	-	ns
Time-out at RX to ignore transition period of EoT	T <sub>HS-SKIP</sub>	40	-	55+4UI	ns
Time to drive LP-11 after HS burst	T <sub>HS-EXIT</sub>	100	-	-	ns
Length of any Low-Power state period	T <sub>LPX</sub>	50	-	-	ns
Sync sequence period	T <sub>HS-SYNC</sub>	-	8UI	-	ns
Minimum lead HS-0 drive period before the Sync sequence	T <sub>HS-ZERO</sub>	105+6UI	-	-	ns

Note:

- The minimum value depends on the bit rate. Implementations should ensure proper operation for all the supported bit rates.
- UI means Unit Interval, equal to one half HS clock period on the Clock Lane.
- T<sub>LPX</sub> is an internal state machine timing reference. Externally measured values may differ slightly from the specified values due to asymmetrical rise and fall times.

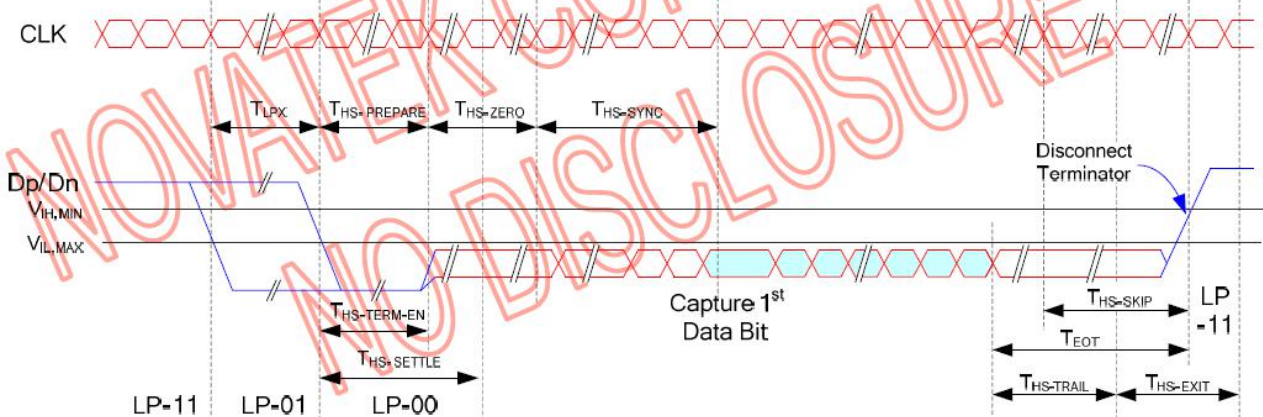

### c. High Speed Clock Transmission(Switching the Clock Lane Operation Timing Parameters)

(VCC=VCC\_IF=1.55V to 1.65V, VDD= 2.7V to 3.6V, AVDD= 7V to 10V, GND=AGND= 0V, TA= -20 to +85°C)

Parameter	Symbol	Min	Typ	Max	Units
Time that the transmitter shall continue sending HS clock after the last associated Data Lane has transitioned to LP mode	$T_{CLK-POST}$	60+52UI	-	-	ns
Detection time that the clock has stopped toggling	$T_{CLK-MISS}$	-	-	60	ns
Time to drive LP-00 to prepare for HS clock transmission	$T_{CLK-PREPARE}$	38	-	95	ns
Minimum lead HS-0 drive period before starting Clock	$T_{CLK-PREPARE} + T_{CLK-ZERO}$	300	-	-	ns
Time to enable Clock Lane receiver line termination measured from when Dn cross $V_{IL,MAX}$	$T_{HS-TERM-EN}$	-	-	38	ns
Minimum time that the HS clock must be set prior to any associated date lane beginning the transmission from LP to HS mode	$T_{CLK-PRE}$	8	-	-	UI
Time to drive HS differential state after last payload clock bit of a HS transmission burst	$T_{CLK-TRAIL}$	60	-	-	ns

Note:

The DSI host processor shall support continuous clock on the Clock Lane for NT chip that require it, so the host processor needs to keep the HS serial clock running.

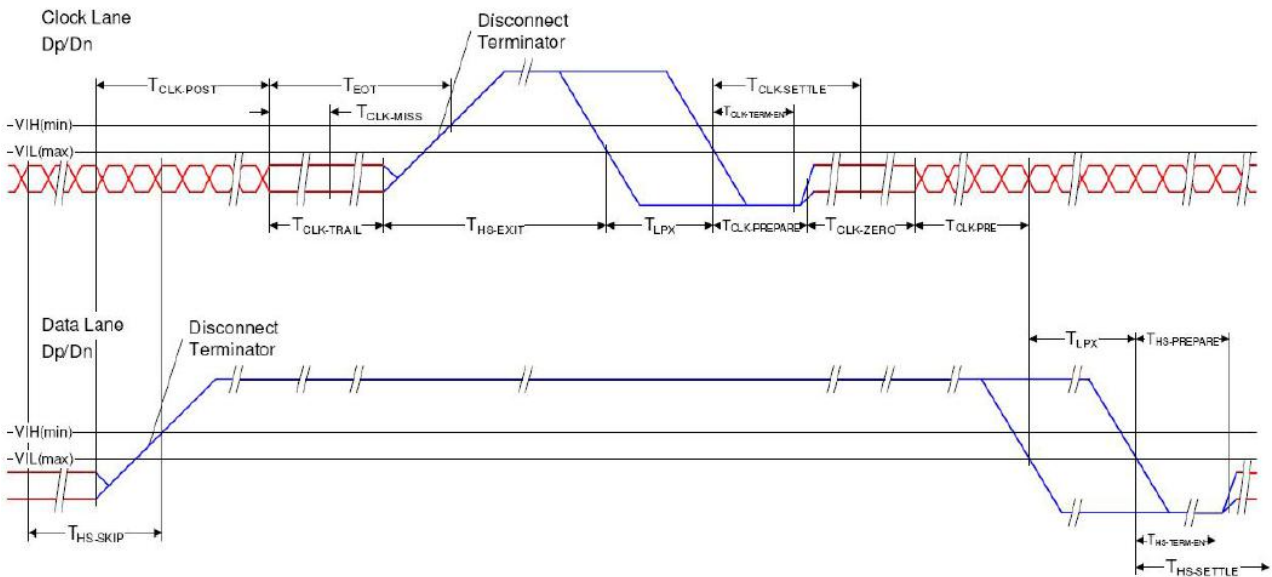



## 5 . Optical Specifications

Item		Symbol	Condition	Values			Unit	Remark	
				Min.	Typ.	Max.			
Viewing angle	Horizontal	$\theta_L$	CR > 10	80	85	-	degree	Note 1	
		$\theta_R$		80	85	-			
	Vertical	$\theta_T$		80	85	-			
		$\theta_B$		80	85	-			
Response time Rise+Fall		$T_{RT}$	Ta=25°C ; $\theta=0^\circ$	-	27	35	ms	Note 2 Note 3	
Contrast ratio		CR	Normal $\theta=\phi=0^\circ$	600	800	-	-	Note 2 Note 4	
Color chromaticity		$W_X$		0.2444	0.3044	0.3644	-	Note 2	
		$W_Y$		0.2581	0.3181	0.3781	-	Note 5	
Color gamut		NTSC		-	50	-	-	%	
Luminance		L		320	400	-	-	cd/m <sup>2</sup>	Note 2
Luminance uniformity		$Y_U$		70	75	-	-	%	Note 2 Note 6

Note 1: Definition of viewing angle range

Viewing angle is the angle at which the contrast ratio is greater than 10. The viewing angles are determined for the horizontal or 3, 9 o'clock direction and the vertical or 6, 12 o'clock direction with respect to the optical axis which is normal to the LCD surface

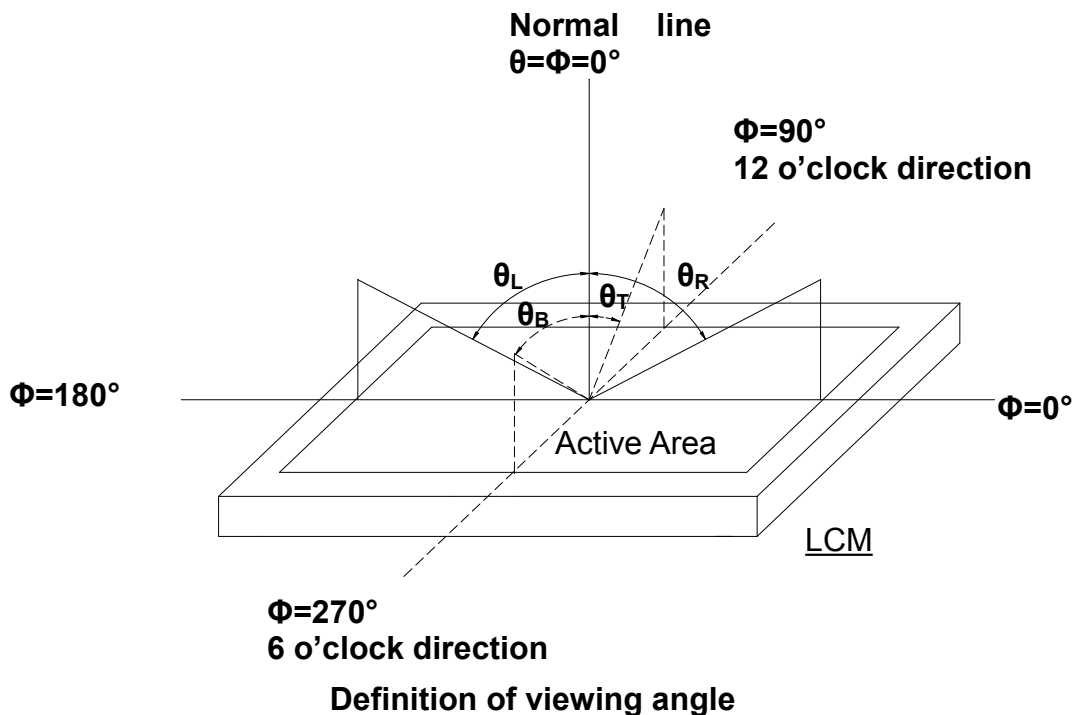

**Note 2: Definition of optical measurement system.**

The optical characteristics should be measured in dark room. After 30 minutes operation, the optical properties are measured at the center point of the LCD screen. (Viewing angle is measured by ELDIM-EZ contrast/Height :1.2mm ,Response time is measured by Photo detector TOPCON BM-7, other items are measured by BM-5A/ Field of view: 1° /Height: 500mm.)

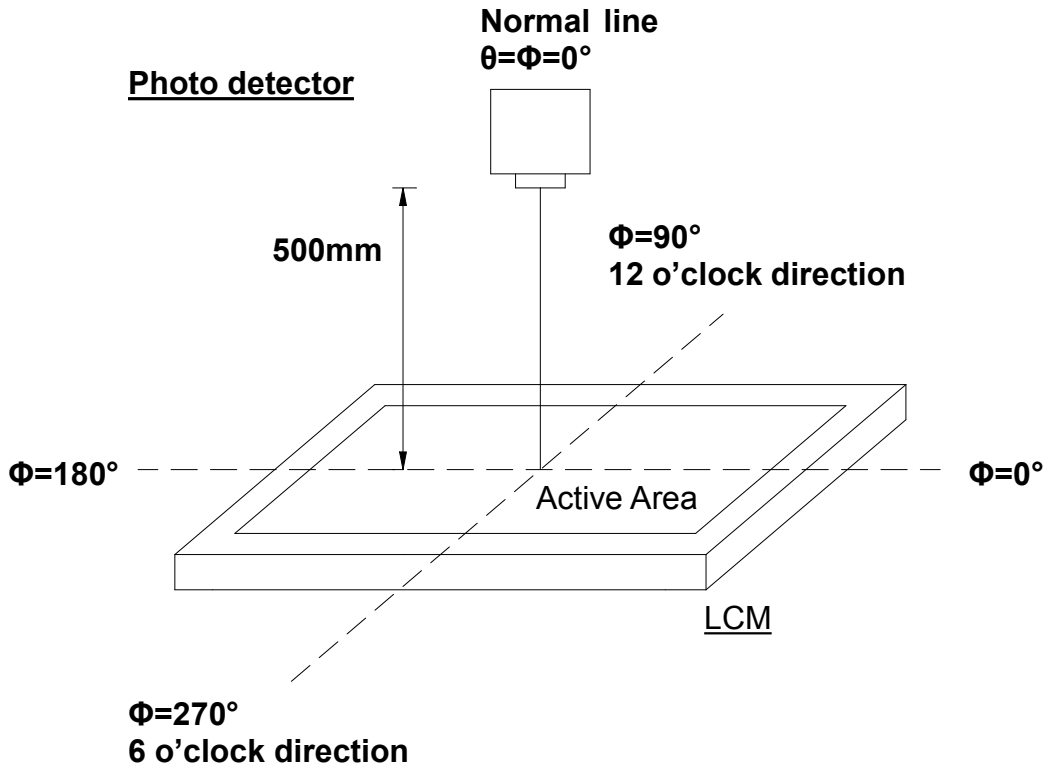

**Note 3: Definition of Response time**

The response time is defined as the LCD optical switching time interval between “White” state and “Black” state. Rise time ( $T_R$ ) is the time between photo detector output intensity changed from 90% to 10%. And fall time ( $T_F$ ) is the time between photo detector output intensity changed from 10% to 90%.

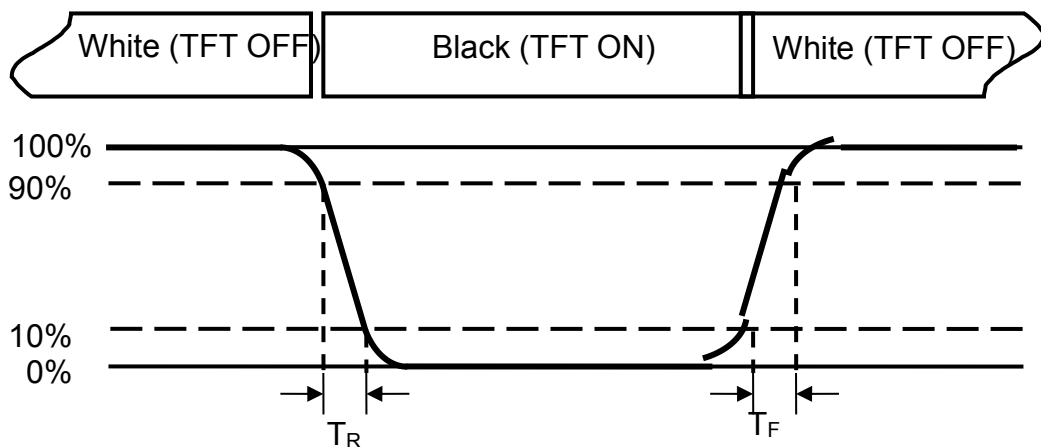

**Definition of response time**

Note 4: Definition of contrast ratio

$$\text{Contrast ratio (CR)} = \frac{\text{Luminance measured when LCD on the "White" state}}{\text{Luminance measured when LCD on the "Black" state}}$$

Note 5: Definition of color chromaticity (CIE1931)

Color coordinates measured at center point of LCD.

Note 6: Definition of Luminance Uniformity ("White" state)

Active area is divided into 9 measuring areas. Every measuring point is placed at the center of each measuring area.

$$\text{Luminance Uniformity (Yu)} = \frac{B_{min}}{B_{max}}$$

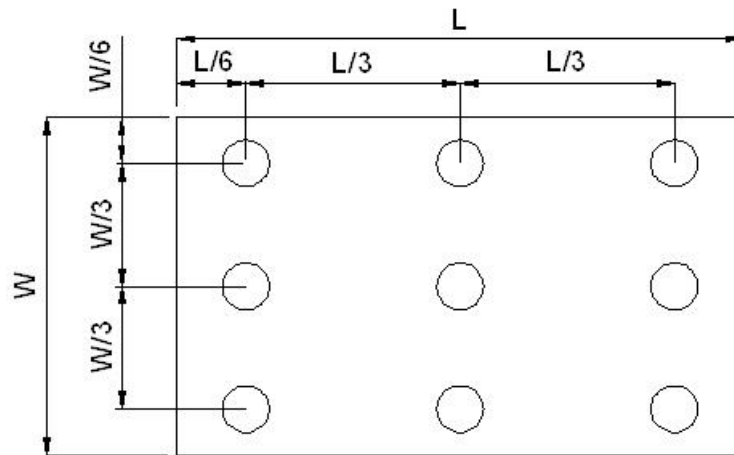

**Definition of measuring points**

$B_{max}$ : The measured maximum luminance of all measurement position.

$B_{min}$ : The measured minimum luminance of all measurement position.

## 6. Reliability Test

Item	Test Conditions		Remark
High Temperature Storage	$T_a = 60^{\circ}\text{C}$	120hrs	
Low Temperature Storage	$T_a = -10^{\circ}\text{C}$	120hrs	
High Temperature Operation	$T_s = 50^{\circ}\text{C}$	120hrs	
Low Temperature Operation	$T_a = 0^{\circ}\text{C}$	120hrs	
High Temperature and Humidity(No condensation)	$+50^{\circ}\text{C}$ , 90%RH max.	120hrs	Non-operation
Thermal Shock	0/30min $\sim$ 50 $^{\circ}\text{C}$ /30min Change time:5min, 10cycle		Non-operation
Electrostatic Discharge	Contact: $\pm 4\text{KV}$ Air: $\pm 8\text{KV}$ 150PF/330 $\Omega$ ,5Points/panel,5times		Class B,Note1

Note1

Class	Performance
A	All functions perform as designed during and after exposure to interference
B	Temporary degradation or less of performance which is self-recoverable
C	Degradation or less of performance which requires operator intervention or system reset to recover
D	Degradation or less of function which is not recoverable

## 7. Handling Precautions

### 7.1 Mounting Method

The LCD panel of Leadtek LCD module consists of two thin glass plates with polarizers which easily be damaged. And since the module is so constructed as to be fixed by utilizing fitting holes in the printed circuit board.

Extreme care should be needed when handling the LCD modules.

### 7.2 Caution Of LCD Handling And Cleaning

When cleaning the display surface, Use soft cloth with solvent [recommended below] and wipe lightly

- Isopropyl alcohol
- Ethyl alcohol

Do not wipe the display surface with dry or hard materials that will damage the polarizer surface.

Do not use the following solvent:

- Water
- Aromatics

Do not wipe ITO pad area with the dry or hard materials that will damage the ITO patterns

Do not use the following solvent on the pad or prevent it from being contaminated:

- Soldering flux
- Chlorine (Cl) , Sulfur (S)

If goods were sent without being silicon coated on the pad, ITO patterns could be damaged due to the corrosion as time goes on.

If ITO corrosion happens by miss-handling or using some materials such as Chlorine (Cl), Sulfur (S) from customer, Responsibility is on customer.

### 7.3 Caution Against Static Charge

The LCD module uses C-MOS LSI drivers, so we recommend that you:

Connect any unused input terminal to V<sub>dd</sub> or V<sub>ss</sub>, do not input any signals before power is turned on, and ground your body, work/assembly areas, assembly equipment to protect against static electricity.

### 7.4 Packing

- Module employs LCD elements and must be treated as such.
- Avoid intense shock and falls from a height.
- To prevent modules from degradation, do not operate or store them exposed directly to sunshine or high temperature/humidity

### 7.5 Caution For Operation

- It is an indispensable condition to drive LCD's within the specified voltage limit since the higher voltage than the limit causes the shorter LCD life.
- An electrochemical reaction due to direct current causes LCD's undesirable deterioration, so that the use of direct current drive should be avoided.
- Response time will be extremely delayed at lower temperature than the operating temperature range and on the other hand at higher temperature LCD's show dark color in them. However those phenomena do not mean malfunction or out of order with LCD's, which will come back in the specified operation temperature.
- If the display area is pushed hard during operation, some font will be abnormally

- displayed but it resumes normal condition after turning off once.
- A slight dew depositing on terminals is a cause for electro-chemical reaction resulting in terminal open circuit.  
Usage under the maximum operating temperature, 50%Rh or less is required.

## 7.6 Storage

In the case of storing for a long period of time for instance, for years for the purpose or replacement use, the following ways are recommended.

- Storage in a polyethylene bag with the opening sealed so as not to enter fresh air outside in it . And with no desiccant.
- Placing in a dark place where neither exposure to direct sunlight nor light's keeping the storage temperature range.
- Storing with no touch on polarizer surface by the anything else.  
[It is recommended to store them as they have been contained in the inner container at the time of delivery from us

## 7.7 Safety

- It is recommendable to crash damaged or unnecessary LCD's into pieces and wash off liquid crystal by either of solvents such as acetone and ethanol, which should be burned up later.
- When any liquid leaked out of a damaged glass cell comes in contact with your hands, please wash it off well with soap and water.

# 8. Precaution For Use

## 8.1

A limit sample should be provided by the both parties on an occasion when the both parties agreed its necessity. Judgment by a limit sample shall take effect after the limit sample has been established and confirmed by the both parties.

## 8.2

On the following occasions, the handing of problem should be decided through discussion and agreement between responsible of the both parties.

- When a question is arisen in this specification
- When a new problem is arisen which is not specified in this specifications
- When an inspection specifications change or operating condition change in customer is reported to LTK , and some problem is arisen in this specification due to the change
- When a new problem is arisen at the customer's operating set for sample evaluation in the customer site.

# 9.Package Drawing

## 9.1 Packing BOM: Please Reference the LCM BOM

### 9.2 Packing Procedure

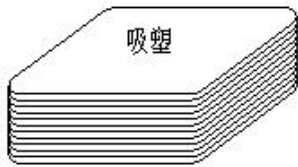

第一步

将产品放入吸塑盘中，LCD AA 面朝上，注意防呆方向

First step

Putting products into the tray, LCD A.A faces Upward, (pay attention to the direction)



第二步

每一层吸塑盘与相邻层，叠放时相错 180 度，最上层不放产品，总叠加层数参考 BOM;

Second step

Neighbouring trays should be staggered 180° while stacking up. on the top, there is an empty tray without product the quality of layers please refer to the BOM

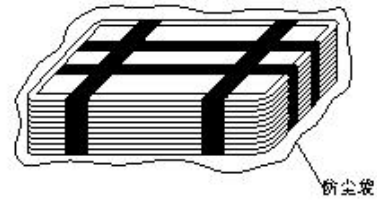

第三步

检查无误后用胶带固定吸塑盘，将捆好的吸塑盘放入无尘带中并封口；

Third step

Taping up the tray after inspection, and put them into a PE bag

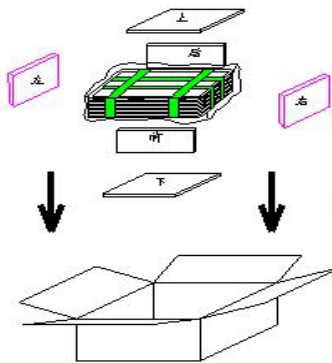

第四步

外箱内侧底部和四周放上泡棉将包好的产品装入纸箱，合盖；

Fourth step

Putting EPE foams and products with trays into the carton; Close the carton box

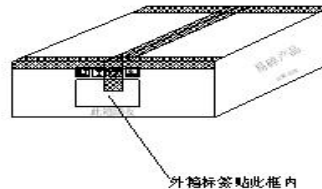

第五步

最后胶带封箱，贴外箱标签

fifth step

Sealing the carton with cellulose tape ;Stick on a carton label

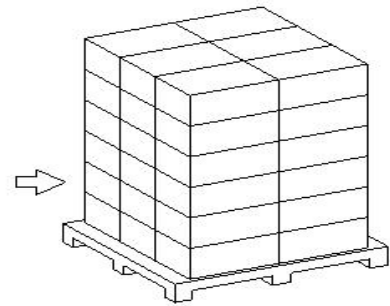

第六步

将每箱整齐放在栈板上并包裹最高可堆叠 6 层)

sixth step

Placing the boxes together on a pallet (6 layers at most)

## 10. Label Drawing

Bar code label and packing chest label  
TBD

## 11. HSF Requirements

- RoHS (Restriction of the use of certain Hazardous Substances)
- HF (Halogen Free)
- REACH (Regulation concerning the Registration, Evaluation, Authorization and Restriction of Chemicals)
- Other regulations

## 12. Scope

This specification applies to the TFT LCD module which is designed and manufactured by LCM Factory of Shenzhen Leadtek Technology Co. Ltd.



### 13.Numbering System

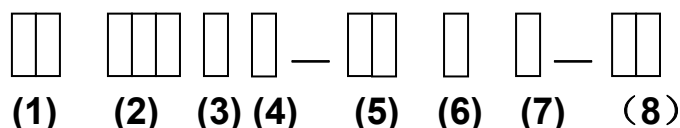

No	Definition	Specifications
(1)	TFT LCM Product No.	Shenzhen Leadtek Technology Co.,Ltd
(2)	Display monitor opposite angle line size	Unit :mm (takes three integers )
(3)	Product Types	D ---- PMP / Tablet PC G ----GPS M ----MP P ----Mobile-Phone N ----Net Book A----Automotive I----Industry
(4)	Product Development Series No.	By two figures characters expression from 1 to 99
(5)	Interface PIN Number	By two figures characters expression from 1 to 99
(6)	With Touch Panel Or Not	T----With T/P ; N----Without T/P
(7)	LCD Type	A----AUO ; M----CMI ; C----CPT; B----BOE; L----LG; W----Wintek; H----HSD; S----Century T----Tianma; Y----Hydis; I----INNOLUX; U---Samsung; V---- IVO; P---- Panasonic
(8)	Product Development edition No.	By The English letters : A1~ Z999

# Capacitive Touch Panel Specification

## 电容式触摸屏规格书

客户名称/Customer Name: \_\_\_\_\_

客户型号/Customer Model: \_\_\_\_\_

型号/ Model:           KDBC080-0397          

### 供应商确认栏 (Supplier Confirmation Column)

研发部 (The R & D Department)		品质部 (The Quality Department)
制订: Formulate		
审核: Check		
批准: Approval		

### 客户确认栏 (Customer Approval Column)

研发部 (The R & D Department)	品质部 (The Quality Department)

# Contents 目录

Revision History 变更履历 .....	3
1. Scope 适用范围 .....	4
2. Structure Characteristics 结构特征.....	4
3. Electrical Characteristics 电气特性.....	4
4. Optical Characteristics 光学特性.....	5
5. Environmental Characteristics 环境特性.....	5
6. Reliability Conditions 可靠性条件.....	6
7. Appearance 外观.....	7
8. Production Lot 批量号（喷码）.....	10
9. Regulation on environment 环境法规.....	11
10. Operating Precautions 使用注意事项.....	11
11. Items concerning business 交易关联事项.....	13
12. Structure 结构图 .....	15

Revision Record 变更履历

Version 版本	Date 变更日期	Summary of Changes 变更点	Page 页数	Owner 制定者
V01	2017-05-31	First Release	15	

## 1. Scope 适用范围

This Specification applies to P/N Projected Capacitive touch panel for reference edition.  
此规格书适用于投射式电容触摸屏产品。

## 2. Structure Characteristics 结构特性

Item 事项		Contents 内容
2-1	VA Size VA 尺寸	_____ 8 _____ Inch 英寸
2-2	Outline Dimension 外形尺寸	193.6*132.6*1.35mm
2-3	Structure 结构	GFF
2-4	Materials 材料	Cover Lens 盖板: 康宁 2320 T=1.1mm
		OCA 光学透明胶: T=0.1mm (Top) T=0.05mm (Bottom)
		ITO Film ITO 膜: T=0.05mm; 方阻 150 Ω/□
2-5	Colour 颜色	黑色
2-6	Total Weight 产品重量	_____ TBD _____ g

## 3. Electrical Characteristics 电气特性

Item 事项		Contents 内容
3-1	IC Type IC 型号	GT9271
3-2	IC Package 封装方式	QFN
3-3	Channel Number 通道数	Rx20*Tx32
3-4	Interface 通信接口	I2C

3-5	Touch of points 触摸点数	10 Points 10 点
3-6	Input Mode 输入方式	Finger 手指
3-7	Input Accuracy 输入精度	中心 1.0MM, 边缘 1.5MM
3-8	Operating Voltage 工作电压	3.3V
3-9	Interface Voltage 接口电压	1.8V
3-10	LCD Resolution LCD 解析度	1200*1920 (RGB)
3-11	Report Rate 报点频率	100HZ
3-12	Current Consumption 耗电量	Normal Operation Mode (正常模式): 13mA; Monitor Mode (检测模式): 4.5mA; Sleep Mode (休眠模式): 0.12mA;

#### 4. Optical Characteristics 光学特性

4-1	Transparency 透过率	≥85%
4-2	Haze 雾度	3%±1%

#### 5. Environmental Characteristics 环境特性

5-1	Operating Temperature 操作温度	-20~ 60°C	<b>Humidity:</b> No dew condensation allowed.  <b>湿度:</b> 不允许结露。
5-2	Storage Temperature 保存温度	-30~ 70°C	

## 6. Reliability Test Conditions 可靠性测试条件

Item 事项		Conditions 条件
6-1	High-temperature Storage 高温保存	T=70°C, 240H
6-2	Low-temperature Storage 低温保存	T=-30°C, 240H
6-3	High-temperature High-humidity Storage 高温高湿保存	T=60°C 90%, 240H
6-4	Heat Shock 热冲击	-20°C(30min) ← (5min Max.) → 60°C(30min)
		50 set
6-5	Electro Static Discharge 抗静电测试	空气放电: ±8KV 接触放电: ±4KV
6-6	Hardness 表面硬度	≥7H
6-7	Ball Drop Test 落球测试	130g 30cm, 中心点 3 次无破碎
<p><b>Note:</b> ① After the test is conducted under the above reliability conditions, the test pieces should be stored in the standard environment for 24 hours and the accuracy of input position given in para4-2 should be satisfied.</p> <p><b>说明:</b> 在进行条件以上可靠性试验后, 在标准状态环境下放置 24 小时, 必须满足 4-2. 输入精度。</p> <p>②The reliability test should be performed with no D.C. power supplied and the touch panel stored on the flat plate. 可靠性试验是触摸屏在非通电、放置于平板上(水平放置)的状态下进行的测试。</p> <p>③The standard condition presents 25±10°C of the temperature, 55±30%of the relative humidity, and 96±10 kPa of the atmospheric pressure. 所谓标准状态, 温度: 25±10°C、相对湿度: 55±30%、气压: 96±10Kpa。</p> <p>④The reliability test should be performed on the touch panel by itself. 对触摸屏单体实施测试</p>		

## 7. Appearance 外观

### 7-1 Application 适用范围

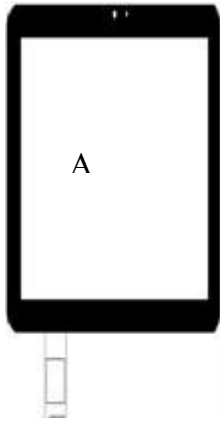

Front side

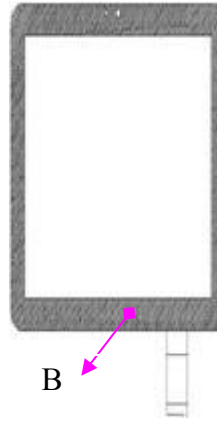

Back side

Area A: The whole front side and view area of back side and transparent hole&semi  
Transparent hole, the following standard applies to this area.

区域 A: 整个产品的正表面及背面可视区, 及透孔、半透孔  
以下的外观检查标准适用于此区域;

Area B: Back side black mask area. Not control area.

区域 B: 产品背面的黑色遮罩区域, 属于非控制区

### 7-2 Appearance Inspection Method 外观检查条件

- (1) The distance between the eye and the product should be  $30\pm 10$  cm, and the inspection should be performed at an angle of  $60^\circ$  or more in relation to the product surface.  
眼睛和产品的距离  $30\pm 10$ cm, 检查角度  $60^\circ$  以上。
- (2) The inspection environment should be such that a fluorescent lamp is used and the illumination intensity is approx.  $600\sim 800$  [lux].  
检查环境普通日光灯照度约为  $600\sim 800$  [lux]。
- (3) The operator should be a person in good health with eyesight 1.0 or higher with correction.  
作业者是 1.0 以上视力的健康成年人。(矫正视力也可)。
- (4) The visual inspection is taken under the inspection environment stated above to find the appearance defects. The defects found at the inspection, will be judged by "Appearance standard" to see if it is recoverable.  
检查环境下进行目视确认外观不良项目、根据外观标准判定合格与否。
- (5) Touch panel is inspected under standard environmental circumstance.  
触摸屏在标准环境条件下检查。
- (6) Inspected Time:  $15\pm 5$  sec, for one pcs (including two sides of the wipe clean).  
检查时间: 每片检查时间不超过 20S (包含产品两面的擦拭、清洁)。

检查范围

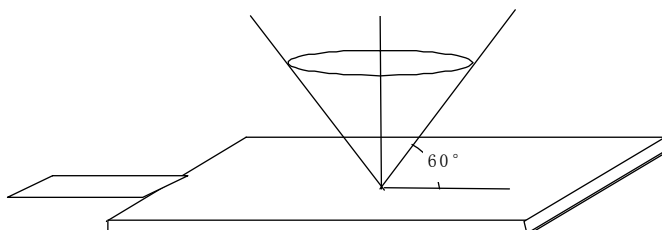



7-3 Appearance Criteria 外观检查规格

(1) 【5寸以下外观检查标准】

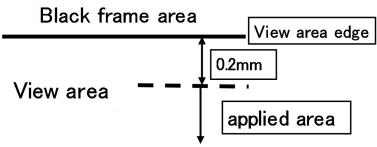
Item 项目	Criteria 规格		Judgment Contents 判定内容	
			VA 区	VA 区以外
Spotted Foreign Object 点状异物	D ≤ 0.1mm		Disregarded 忽视	
	0.1mm < D ≤ 0.3mm		N ≤ 3 (间距 10MM 以上)	忽视
	D > 0.3mm		Fault 不良	忽视
Linear Foreign Object, 线状异物	W ≤ 0.01mm		Disregarded 忽视	
	0.01mm < W ≤ 0.03mm 且 L ≤ 5mm		N ≤ 2 (间距 10MM 以上)	忽视
	0.03mm < W ≤ 0.05mm 且 L ≤ 5mm		N ≤ 2 (间距 10MM 以上)	忽视
	W > 0.05mm		NG	按点状异物规格判定
Scratch 划伤	W ≤ 0.01mm		Disregarded 忽视	
	0.01mm < W ≤ 0.03mm 且 L ≤ 5mm		N ≤ 2 (间距 10MM 以上)	忽视
	0.03mm < W ≤ 0.05mm 且 L ≤ 5mm		N ≤ 2 (间距 10MM 以上)	忽视
	W > 0.05mm		NG	按点状异物规格判定
Air bubbles inside of adhesive 光学胶内气泡	D ≤ 0.1mm	Disregarded 忽视	Applied to 0.2mm or more inward from the View Area edge. 保证区域为 VA 边界 0.2mm 之外。 	
	0.1 < D ≤ 0.3mm	N ≤ 2 and DS > 10mm		
	D > 0.3mm	Fault 不良		

(2) 【5寸—7寸外观检查标准】

Item 项目	Criteria 规格		Judgment Contents 判定内容	
			VA 区	VA 区以外
Spotted Foreign Object 点状异物	D ≤ 0.20mm		Disregarded 忽视	
	0.2mm < D ≤ 0.35mm		N ≤ 3 (间距 10MM 以上)	忽视
	D > 0.35mm		Fault 不良	忽视
Linear Foreign Object, 线状异物	W ≤ 0.02mm		Disregarded 忽视	
	0.02mm < W ≤ 0.05mm 且 L ≤ 8mm		N ≤ 2 (间距 10MM 以上)	忽视
	0.05mm < W ≤ 0.07mm 且 L ≤ 6mm		N ≤ 2 (间距 20MM 以上)	忽视
	W > 0.07mm		NG	按点状异物规格判定

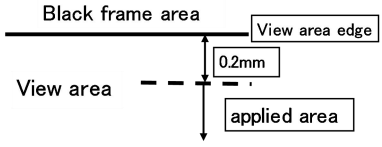
Scratch 划伤	$W \leq 0.02\text{mm}$	Disregarded 忽视	
	$0.02\text{mm} < W \leq 0.05\text{mm}$ 且 $L \leq 8\text{mm}$	$N \leq 2$ (间距 10MM 以上)	
	$0.05\text{mm} < W \leq 0.07\text{mm}$ 且 $L \leq 6\text{mm}$	$N \leq 2$ (间距 20MM 以上)	
	$W > 0.07\text{mm}$	NG	
Air bubbles inside of adhesive 光学胶内气泡	$D \leq 0.2\text{mm}$	Disregarded 忽视	Applied to 0.2mm or more inward from the View Area edge. 保证区域为 VA 边界 0.2mm 之外。 
	$0.2\text{mm} < D \leq 0.35\text{mm}$	$N \leq 2$ and $DS > 10\text{mm}$	
	$D > 0.35\text{mm}$	Fault 不良	

### (3) 【7 寸—12.2 寸外观检查标准】

Item 项目	Criteria 规格	Judgment Contents 判定内容	
		VA 区	VA 区以外
Spotted Foreign Object 点状异物	$D \leq 0.2\text{mm}$	Disregarded 忽视	
	$0.2\text{mm} < D \leq 0.4\text{mm}$	$N \leq 3$ (间距 10MM 以上)	忽视
	$D > 0.4\text{mm}$	Fault 不良	忽视
Linear Foreign Object, 线状异物	$W \leq 0.03\text{mm}$	Disregarded 忽视	
	$0.03\text{mm} < W \leq 0.07\text{mm}$ 且 $L \leq 8\text{mm}$	$N \leq 2$ (间距 10MM 以上)	忽视
	$0.07\text{mm} < W \leq 0.1\text{mm}$ 且 $L \leq 6\text{mm}$	$N \leq 2$ (间距 20MM 以上)	忽视
	$W > 0.1\text{mm}$	NG	按点状异物规格判定
Scratch 划伤	$W \leq 0.03\text{mm}$	Disregarded 忽视	
	$0.03\text{mm} < W \leq 0.07\text{mm}$ 且 $L \leq 8\text{mm}$	$N \leq 2$ (间距 10MM 以上)	忽视
	$0.07\text{mm} < W \leq 0.1\text{mm}$ 且 $L \leq 6\text{mm}$	$N \leq 2$ (间距 20MM 以上)	忽视
	$W > 0.1\text{mm}$	NG	按点状异物规格判定
Air bubbles inside of adhesive 光学胶内气泡	$D \leq 0.2\text{mm}$	Disregard ed 忽视	Applied to 0.2mm or more inward from the View Area edge. 保证区域为 VA 边界 0.2mm 之外。 
	$0.2\text{mm} < D \leq 0.4\text{mm}$	$N \leq 2$ and $DS > 10\text{mm}$	
	$D > 0.4\text{mm}$	Fault 不良	

**【所有尺寸通用项目检查标准】**

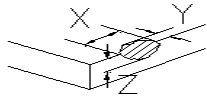
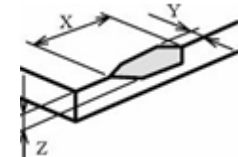
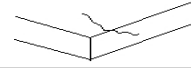
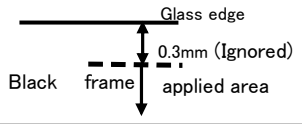
Fragments 玻璃缺	Fragments (Surface)	$X \leq 0.5\text{mm}$ , $Y \leq 0.5\text{mm}$ , $Z \leq 1/2\text{glass thickness}$		It must not influence the function 不影响功能
	Fragments (Back)	$X \leq 0.5\text{mm}$ , $Y \leq 0.3\text{mm}$ , $Z \leq 1/2\text{glass thickness}$		It must not influence the function 不影响功能
	Progressive crack 恶延伸恶化性裂痕			Fault 不良
Pinhole 针孔、油墨缺	$D \leq 0.1$	Disregarded 忽视		
	$0.1 < D \leq 0.2\text{mm}$		Ignored up to 1pcs 允许 3 个 (每边限 1 个)	
	$D > 0.2\text{mm}$		Fault 不良	
Stains 污	<p>1、Sharply outlined stains should be regarded as foreign matter. 形状明显的污按照异物标准判定。</p> <p>2、Stains not sharply outlined should be judged by transmitted light, which should be acceptable if invisible. Also, stains that can be wiped out with a soft moistened cloth in ethanol should be acceptable. 形状不明显的污，在投射光下不可见，判定为良品；可以用沾有乙醇的湿布擦出的污也判定为良品</p>			

**7-4 Other 其它**

Acceptance or rejection should be judged with the actual final equipment if needed, and the Touch Panel that is allowable in practical use should be accepted. As long as there is any doubt, discussion is required.  
如果有限度样版，优先考虑限度样版。  
Criteria regarded If not visible w reflective light inspection.  
如有疑议，另行商议。

**8. Production Lot 批量号 (喷码)**

The lot seal should be bonded on the touch panel to identify the production lot.  
为了区别交付的触摸屏批量号，在触摸屏上进行喷码。  
The location of lot seal refer to the drawing.  
(喷码位置参照图纸)。

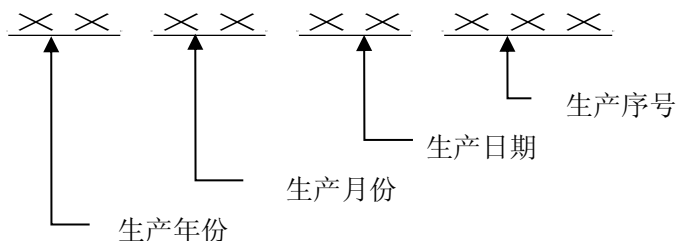

## 9. Regulation on environment 环境法规

### 9-1. RoHS directive RoHS 指令

This product is corresponded to RoHS directive.

“Corresponded to RoHS directive” is judged based on EU Directive 2002/95/EC.

本产品符合 RoHS 指令，遵循欧盟 2002/95/EC 的指令。

### 9-2. Other 其他

Requirement for the other restricted material needs to be cleared and it should be decided on discussion between our customer and us.

对于其他限制物质的要求应该说明，依商讨内容为准。

## 10. Operating Precautions 使用注意事项

### 10-1. Chassis Mechanical Design 框体结构设计

- a. Please use the touch panel as a replaceable unit when you are designing your product. (Please do not consider the touch panel as an permanent item.).  
设计时请将触摸屏作为可更换的部件来考虑（将触摸屏作为寿命产品来考虑）。
- b. Assuming input method for customers' use, design the chassis so that no chassis strain or the like has an influence on the touch panel by the hand placed on the chassis, for example.  
考虑到用户的使用时的状态，例如，当把手压到框体时要确保不会对触摸屏产生影响。
- c. Select insulation material when considering construction material for the chassis. It may lead to a cause of false operation when conductive material is used as the chassis. 请选择绝缘的材料作为框体，使用导电性材料可能会引起误动作。
- d. When inserting a spacer (such as a cushioning material) between the touch panel and chassis for the purpose of dust proofing, pay attention to the following:  
以防尘为目的在触摸屏和框体之间夹放垫片（缓冲材）时，要注意以下几点：
  - (1) Fix a spacer to the chassis side: avoid bonding it to the touch panel.  
缓冲材要固定在框体侧，而不要粘贴在触摸屏上。
  - (2) Select insulation materials as the spacer and locate it outside of key area.  
选择绝缘的材料作为缓冲材，且要置于键入区外部
- e. When distance with the touch panel is near to LCD, Touch panel may malfunction by the influence of the noise from LCD; the touch panel' s structure may be different according to the LCD' s type. When using a VCOM type LCD, A shielding Layer is recommend. 当触摸屏与 LCD 距离太近时，触摸屏可能会因 LCD 的噪音产生误动作；根据液晶类型的不同，触摸屏的结构可能有所不同。当使用 VCOM 类型的液晶时，建议使用有屏蔽层结构的设计。
- f. Pay attention for not to make any stress of deformation.  
请注意不要施重压而使触摸屏变形。
- g. Avoid performing adhesion with the touch panel inclined or uneven. This inclination and shift may lead to positional deviation at input. 请避免触摸屏和 LCD 贴合的倾斜和不平行，这种倾斜和偏移可能会造成输入的偏移

### 10-2. Flexible Connector FPC 连接器

- a. The effective part for the attachment of flexible connector and the touch panel main body should be the deflection of R=3.0mm or more.

FPC 上的附件的有效组成部分和触摸屏本体应该有 R 3.0mm 或更大 的扰度。

b. For flexible connector arrangement, R=2.0mm or more should be maintained so that the circuitry will not crease.

对于 FPC 的组装，应该有 R 3.0mm 或更大的扰度，这样就线路就不会起褶皱

c. Please do not bend the chip mounting area.

不要弯曲芯片放置位置

d. For the connector side of the FPC:关于 FPC 连接器侧

(1) If the pressure in the contact part of circuit side connector and flexible connector wiring is too large, there may arise deflection in the wiring, that could cause contact failure; it is ,therefore, necessary to verify the impact of the connector on the FPC as well as the influence of thermal stress, etc. Using the actual machine before selecting the connector;

如果在 FPC 接触部的压力过大，有可能会出出现偏移而造成接触失效；所以有必要用实物验证连接器的压力及热影响；

(2) After checking the applicable conductor, select the circuit side connector.

The general connector for FPC is designed, assuming the metallic wiring; some connectors are large in pressure in the contact part and sharp in shape.

在确定了可用的 FPC 连接器后，再选择 FPC.

### 10-3. Touch Panel Handling 触摸屏的使用

Handing 拿取	(1) Do not lift up the product by holding the flexible connector. 请不要手持 FPC 来提取产品。
Installation 组装	(1) Since the glass substrate has some sharp edges, use fingerstalls or gloves, etc., and handle with special care. <b>请注意：</b> 因为有锐利的部分，必须在戴指套，手套等的情况下使用。 (2) Note that if the flexible connector is pressed against the glass edge, electrode disconnection or burnout may occur. <b>请注意：</b> 如果把 FPC 按压在玻璃端面有可能会造成断线的现象。
Unpacking 拆卸	(1) Always remove the touch panel for maintenance after satisfactory cooling. 请确保触摸屏在完全冷却的状态下进行拆装与维修。
Cleaning 清洁	(1) When re-adhering the protecting film, check for stains. These stains can be transferred. 将产品的保护膜重新贴上时，请确认保护膜上是否有污，因为有可能产生转写污。 (2) If the touch panel is stored with the protecting film attached for a long period of time, the pressure sensitive adhesive of protecting film may stick to the touch panel as stains. Lightly wipe out the stains with a soft moistened cloth in ethanol. 贴上保护膜长时间保存时，会造成保护膜上的粘着剂形成污转写到触摸屏表面。若表面有转写污，请用软布，沾少量酒精轻擦掉此污。 (3) Do not apply water or chemicals other than alcohol such as ethanol to the touch panel. In particular, do not allow liquid put on the touch panel face side. 请不要在触摸屏上沾酒精以外的化学药品及水。特别是触摸屏的端面不能附着液体。

Storage 保存	<p>(1) Store the touch panel indoor in the packing case (in the condition in which it was delivered) at 10°C or higher, 40°C Max. and below 60% in humidity. The glue of touch panel protecting film may possibly be transferred as stains. 包装好的产品（交货时的状态），在 10°C 以上 40°C 以下、湿度 60% 以下的环境下保存。请注意：产品若长期放置，保护膜的胶有可能变成污转写到触摸屏上。</p> <p>(2) Do not store the touch panel in a high temperature and humidity for a long period of time and avoid storage in the environment where condensation could arise. 请不要长期保存在高温高湿环境下。特别是绝不能保存在会产生结露的环境中。</p>
Other 其它	<p>(1) Do not store nor use under outside and UV exposing environment like mercury light bulb, permanently because serious performance damage may occur. Touch panel has a certain life, so life is different depending on your usage circumstance. 请避免触摸屏，在屋外及有水银灯等紫外线照射的环境下长期放置和使用，因为这会对其性能产生很大的影响。触摸屏是有寿命的产品，且因使用环境的不同而变化。</p> <p>(2) Be careful of dew occurring in case there is difference of temperature between outside and inside of device (i.e. display monitor). If dew may occur, electrical shortage between electrode. And/or deterioration of conductive layer may happen. <b>请注意：</b>当外部温度和机械内部温度（表示装置等）有温差时、容易产生结露。如果发生结露，有可能导致上下电极间发生短路及电阻膜劣化的现象。</p> <p>(3) Operating temperature is under installed inside equipment without relating on or off status. Non operating temperature means the status of touch panel alone. 动作温度是指触摸屏实装于产品状态下的温度（与通电与否无关）。非通电温度是指触摸品单体状态时的温度。</p>

## 11. Items concerning business 交易关联事项

### 11-1. Warranty Period and Warranty Range 保证期限及保证范围

#### (1) Warranty period 保证期限

One year after the date of delivery. 交付后一年。

#### (2) Warranty range 保证范围

If Touch Panel is failed and damaged due to our company's cause within the warranty period, we will repair or replace it.

保证期限内, 由于本公司的原因导致的故障、损伤时, 我司将进行修理或更换新的良品。

As far as compensation, repair or replacement should be limited to our delivered touch panel itself. Damage induced due to delivered touch Panel failure is out of our warranty. The repair or replacement in the field are also out of our warranty.

另外，关于补偿，只对交付品（触摸屏的单体）的实物进行交换。

由于产品的故障而引发相关损害以及在当地进行维修、更换的所引起的相关费用，本公司一律不给予补偿。

The assurance range and time of environmental characteristics reference to reliability conditions of the No.7.

环境特性的保证范围和时间以第7项可靠性试验为准。

The following cases are excluded from the warranty range:

下述情况不属于本公司的保证范围。

- (a) Failure and damage caused by handling nonconformities, such as drop and shocks during transportation (movement) after delivery  
交付后，由于贵公司的使用不当（如移动，运输时的跌落、撞击等）而引起的故障、损伤的情况。
- (b) Failure and damage caused by disasters  
天灾等因灾害引起的故障、损伤的情况。
- (c) Repair and modification at other than our company  
非经本公司进行的修理而被改造了的情况。
- (d) Failure and damage caused by handling contrary to “Touch Panel Operating Precautions” described in this Specification.  
违反本规格说明书中所记载了的使用方法及注意事项而引起的故障、损伤的情况。

#### 11-2. Remarks 备注

- (1) Once your company receive this specification, if no confirmation and signing back without reasonable notice within 15 days, we will consider it to be self-executing.  
贵公司收到本规格书 15 日内，若因贵公司原因一直没有正式确认、回签，我司则视为自动生效。
- (2) The discription above is translated from Chinese version. If you have any questions, please kindly refer to the Chinese version. Any inconvenience, please kindly forgive us.  
以上英文描述均为中文翻译成英文的内容，若有不明处，请以中文版的说明书内容为准。若有不便，敬请谅解！

## 12. Structure 结构图

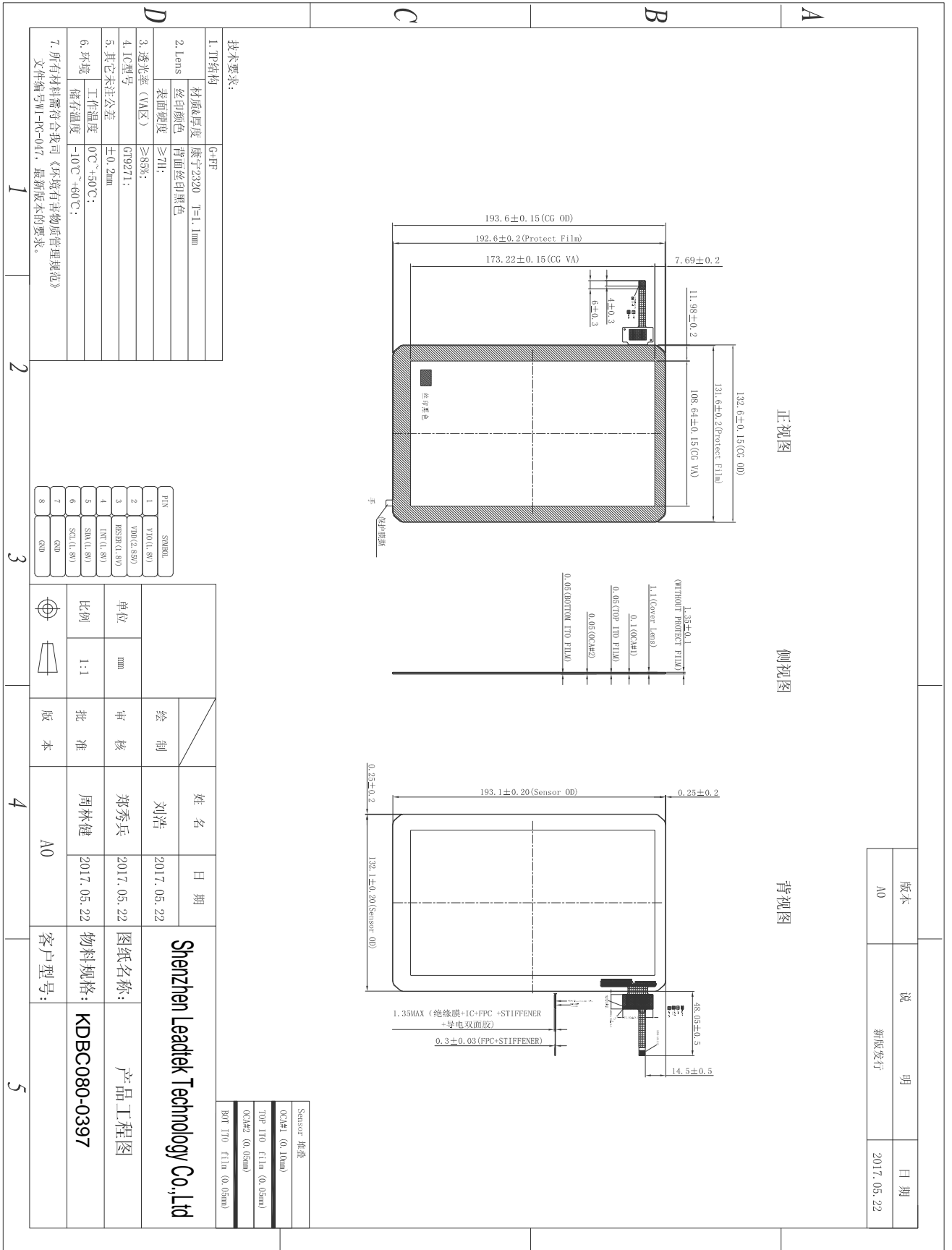



Компания «Life Electronics» занимается поставками электронных компонентов импортного и отечественного производства от производителей и со складов крупных дистрибьюторов Европы, Америки и Азии.

С конца 2013 года компания активно расширяет линейку поставок компонентов по направлению коаксиальный кабель, кварцевые генераторы и конденсаторы (керамические, пленочные, электролитические), за счёт заключения дистрибьюторских договоров

Мы предлагаем:

- Конкурентоспособные цены и скидки постоянным клиентам.
- Специальные условия для постоянных клиентов.
- Подбор аналогов.
- Поставку компонентов в любых объемах, удовлетворяющих вашим потребностям.
- Приемлемые сроки поставки, возможна ускоренная поставка.
- Доставку товара в любую точку России и стран СНГ.
- Комплексную поставку.
- Работу по проектам и поставку образцов.
- Формирование склада под заказчика.
- Сертификаты соответствия на поставляемую продукцию (по желанию клиента).
- Тестирование поставляемой продукции.
- Поставку компонентов, требующих военную и космическую приемку.
- Входной контроль качества.
- Наличие сертификата ISO.

В составе нашей компании организован Конструкторский отдел, призванный помогать разработчикам, и инженерам.

Конструкторский отдел помогает осуществить:

- Регистрацию проекта у производителя компонентов.
- Техническую поддержку проекта.
- Защиту от снятия компонента с производства.
- Оценку стоимости проекта по компонентам.
- Изготовление тестовой платы монтаж и пусконаладочные работы.



Тел: +7 (812) 336 43 04 (многоканальный)

Email: [org@lifeelectronics.ru](mailto:org@lifeelectronics.ru)