

# Motor Drivers for Printers System Driver for Ink Jet Printers



BD64550EFV

No.10016EAT03

## ●Description

This is 1-chip system motor driver integrating 2-channel H-bridge driver, step-down switching regulator with built-in power DMOS, series regulator and reset output.

## ●Features

- 1) Low-on resistance output H-bridge driver (2-channel)
- 2) Constant-current chopping drive H-bridge driver
- 3) Switching regulator with built-in P-channel power DMOS FET
- 4) Soft start function: 23.6 ms (Typ.)
- 5) Reset release timer: 80 ms (Typ.)
- 6) 16 bit serial interface
- 7) Logic input interface (serial/parallel changeable)
- 8) Ultra thin type high heat dissipation HTSSOP-B40 package
- 9) Overcurrent protection in H-bridge driver block
- 10) Input voltage low voltage protection in H-bridge driver block
- 11) Overcurrent protection in switching regulator block
- 12) Output overvoltage protection in switching regulator block
- 13) Output low voltage protection in switching regulator block
- 14) Thermal shutdown

## ●Applications

Inkjet printer, photo printer, etc.

## ●Absolute Maximum Ratings (Ta=25°C)

Parameter	Symbol	Ratings	Unit
VM applied voltage	$V_M$	40	V
Logic input voltage	$V_L$	-0.4 ~ 5.5	V
RIN applied voltage	$V_{RIN}$	5.5	V
RNF voltage	$V_{RNF}$	0.5	V
Power dissipation	$P_d$	1600*	mW
Operating temperature range	$T_{OPR}$	-25 ~ +85	°C
Storage temperature range	$T_{STG}$	-55 ~ +150	°C
Junction temperature	$T_{jmax}$	150	°C
Motor driver output current (peak 500 ns)	$I_{omax}$ (peak)	8.0	A
Motor driver output current (DC)	$I_{omax}$ (DC)	2.5**	A
Switching regulator output current (DC)	$I_{omax}$	0.5	A
Series regulator output current (DC)	$I_{omax}$	0.25	A

\* Reduced by 12.8 mW/°C over 25 °C, when mounted on a glass epoxy board (70 mm x 70 mm x 1.6 mm).

\*\* Must not exceed Pd or ASO.

## ●Operating Conditions

Parameter	Symbol	Limit	Unit
VM operating power supply voltage range	$V_M$	7 ~ 36	V
SCLK max. operating frequency	$F_{SCLK}$	20	MHz
Switching regulator output voltage range	$V_{swreg}$	3 ~ 5	V

●Electrical Characteristics (Unless otherwise specified, Ta=25°C, V<sub>M</sub>=24V)

Parameter	Symbol	Limit			Unit	Conditions
		Min.	Typ.	Max.		
<b>Overall</b>						
VM current 1	I <sub>VM1</sub>	-	-	8	mA	V <sub>M</sub> =7V
VM current 2	I <sub>VM2</sub>	-	-	12	mA	V <sub>M</sub> =24V
<b>H-bridge 1</b>						
Output on resistance (source side))	R <sub>ONH1</sub>	-	0.6	0.78	Ω	I <sub>o</sub> =1A
Output on resistance (sinking side)	R <sub>ONL1</sub>	-	0.4	0.52	Ω	I <sub>o</sub> =1A
Output leak current	I <sub>LEAK1</sub>	0	-	10	μA	V <sub>M</sub> =36V
Built-in diode forward direction voltage (source side)	V <sub>FH1</sub>	0.6	0.9	1.2	V	I <sub>o</sub> =1A
Built-in diode forward direction voltage (sinking side)	V <sub>FL1</sub>	0.6	0.9	1.2	V	I <sub>o</sub> =1A
<b>H-bridge 2</b>						
Output on resistance (source side)	R <sub>ONH2</sub>	-	0.7	0.91	Ω	I <sub>o</sub> =1A
Output on resistance (sinking side)	R <sub>ONL2</sub>	-	0.5	0.65	Ω	I <sub>o</sub> =1A
Output leak current	I <sub>LEAK2</sub>	0	-	10	μA	V <sub>M</sub> =36V
Built-in diode forward direction voltage (source side)	V <sub>FH2</sub>	0.6	0.9	1.2	V	I <sub>o</sub> =1A
Built-in diode forward direction voltage (sinking side)	V <sub>FL2</sub>	0.6	0.9	1.2	V	I <sub>o</sub> =1A
<b>Current control</b>						
VREF voltage range	V <sub>REF</sub>	0.8	-	3.5	V	
VREF pin outflow current	I <sub>REF</sub>	-	0	1	μA	
RNF pin outflow current	I <sub>RNF</sub>	5	15	30	μA	
RNFS pin outflow current	I <sub>RNFS</sub>	-	0	1	μA	
VREF-RNFS offset voltage	V <sub>OFFSET</sub>	-15	0	15	mV	VREF=2V
<b>Control logic</b>						
High input voltage	V <sub>INH</sub>	2.0	-	5.5	V	
Low input voltage	V <sub>INL</sub>	0	-	0.8	V	
Input current	I <sub>IN</sub>	21	33	45	μA	Input voltage=3.3V
<b>Switching power source</b>						
DSEN threshold voltage	V <sub>SWBIAS</sub>	0.873	0.9	0.927	V	
Output on resistance	R <sub>SWON</sub>	-	0.8	1.04	Ω	At I <sub>o</sub> =250mA
Leak current	I <sub>SWLEAK</sub>	0	-	10	μA	V <sub>M</sub> =36V
DUTY_MAX value	D <sub>MAX</sub>	-	92	-	%	
Clock frequency	F <sub>SW</sub>	130	200	270	kHz	
DSEN pin outflow current	I <sub>DSEN</sub>	-	0	1	μA	
<b>Series power source</b>						
Output voltage	V <sub>SOUT</sub>	1.425	1.5	1.575	V	At I <sub>o</sub> =70mA
Leak current	I <sub>SLEAK</sub>	0	-	10	μA	
<b>RESET pin</b>						
Output voltage	V <sub>RSTL</sub>	0	-	0.2	V	I <sub>DRAIN</sub> =1mA
Leak current	I <sub>RSTLEAK</sub>	0	-	10	μA	
High VM threshold voltage	V <sub>MPORH</sub>	6.3	6.5	6.7	V	V <sub>M</sub> at power on
Low VM threshold voltage	V <sub>MPORL</sub>	5.9	6.1	6.3	V	V <sub>M</sub> at power off
High motor UVLO voltage	V <sub>MMTH</sub>	13.5	15	16.5	V	Off motor only
Low motor UVLO voltage	V <sub>MMTL</sub>	12.5	14	15.5	V	
Reset delay time	T <sub>POR</sub>	50	80	110	ms	

●Reference Data

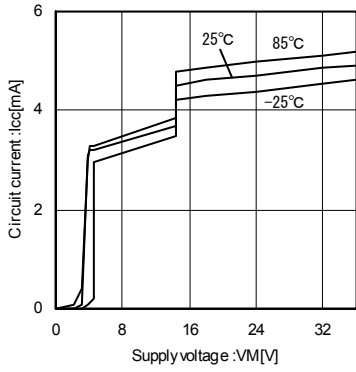

Fig.1 VM Current

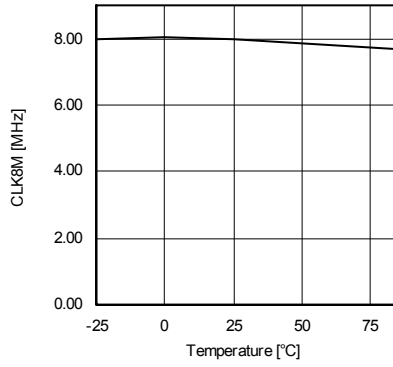

Fig.2 Internal Reference Clock (VM=24V)

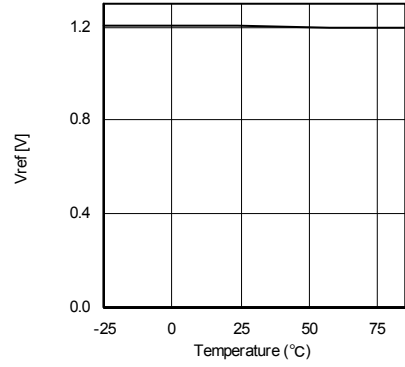

Fig.3 Temperature dependence of Internal Standard Voltage (VM=24V)

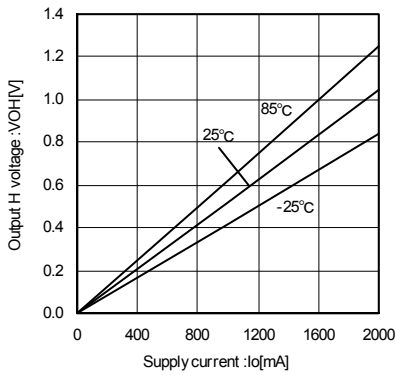

Fig.4 OUT1 High Output Voltage (source side)

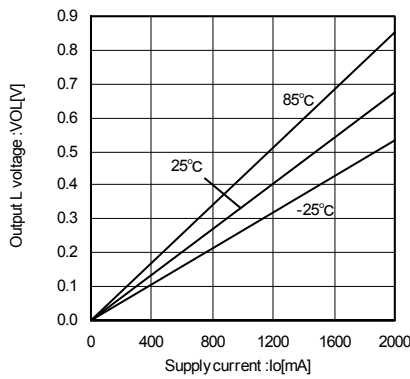

Fig.5 OUT1 Low Output Voltage (sinking side)

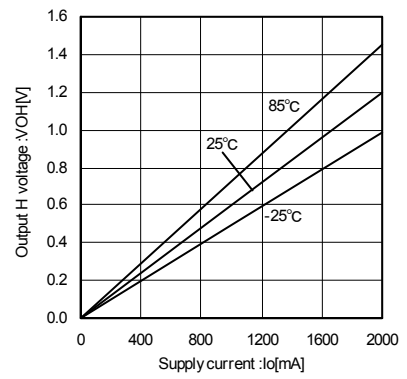

Fig.6 OUT2 High Output Voltage (source side)

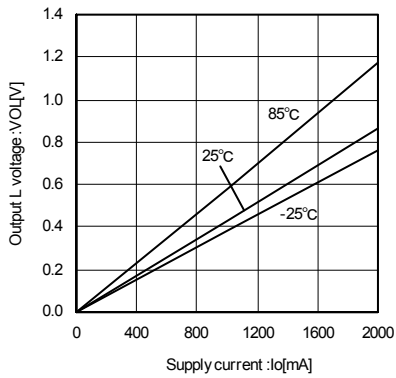

Fig.7 OUT2 Low Output Voltage (sinking side)

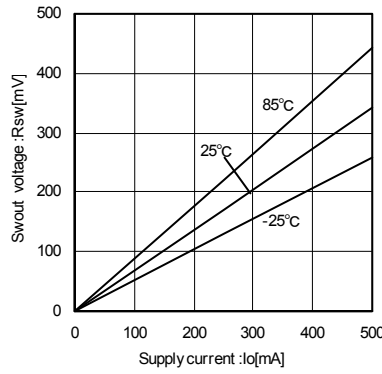

Fig.8 Switching Regulator High Output Voltage

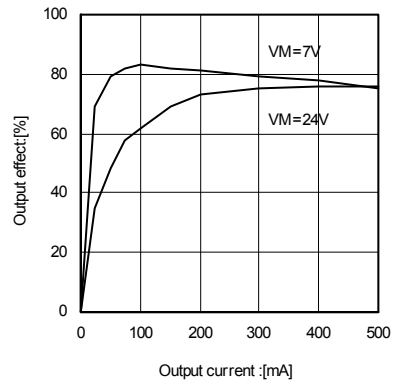

Fig.9 Switching Regulator Efficiency (Ta=25°C)

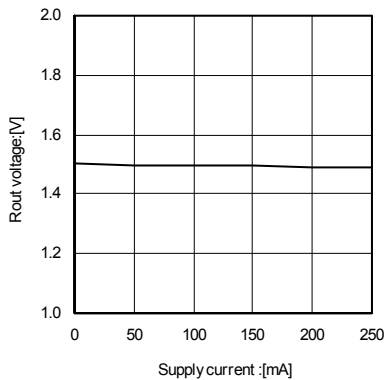

Fig.10 Series Regulator Load Regulation (VM=24V, Ta=25°C)

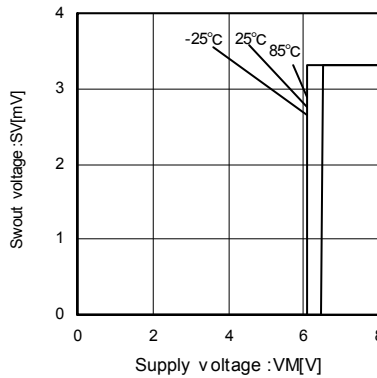

Fig.11 Reset Output (Pull up to switching regulator at 10kΩ)

●Block Diagram, Application Circuit Diagram, and Pin Function

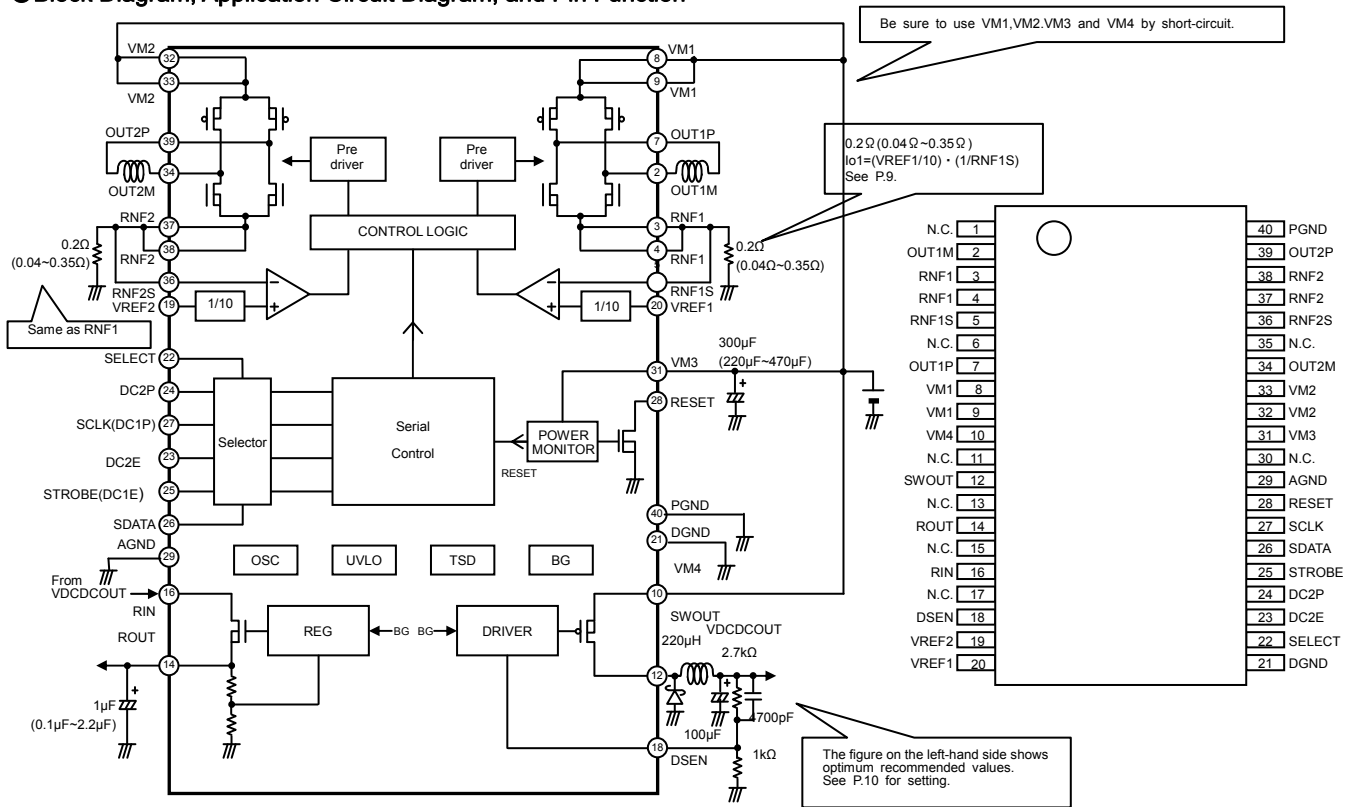

Fig.12 Block Diagram and Application Circuit Diagram

Fig.13 Pin Assignment Diagram

No.	Pin name	Function	No.	Pin name	Function
1	NC	Non Connection	21	DGND	Digital GND
2	OUT1M	H-bridge output pin 1M	22	SELECT	Input pin select pin
3	RNF1	Output current detection pin 1	23	DC2E	H-bridge 2 side enable input pin
4	RNF1	Output current detection pin 1	24	DC2P	H-bridge 2 side phase pin
5	RNF1S	Output current detection input pin	25	STROBE	Serial port strobe input pin / H-bridge 1 side enable pin
6	NC	Non Connection	26	SDATA	Serial port data input pin
7	OUT1P	H-bridge output pin 1P	27	SCLK	Serial port clock input pin / H-bridge 1 side phase input pin
8	VM1	Motor power supply pin	28	RESET	Reset signal output pin
9	VM1	Motor power supply pin	29	AGND	ANALOG GND
10	VM4	Switching regulator power supply pin	30	NC	Non Connection
11	NC	Non Connection	31	VM3	Power supply pin
12	SWOUT	Switching regulator output pin	32	VM2	Motor power supply pin
13	NC	Non Connection	33	VM2	Motor power supply pin
14	ROUT	Series regulator output pin	34	OUT2M	H-bridge output pin 2M
15	NC	Non Connection	35	NC	Non Connection
16	RIN	Series regulator power supply pin	36	RNF2S	Output current detection input pin
17	NC	Non Connection	37	RNF2	Output current detection pin 2
18	DSEN	Switching regulator voltage sense pin	38	RNF2	Output current detection pin 2
19	VREF2	Reference voltage input pin	39	OUT2P	H-bridge output pin 2P
20	VREF1	Reference voltage input pin	40	PGND	POWER GND

\* Precaution regarding VM pin  
 If you use VM1, VM2, VM3 and VM4 not by short-circuit, they may be destroyed. Be sure to use them by short-circuit.  
 And be sure to set up a bypass capacitor (220µF to 470µF) closer to VM3 pin as much as possible.

●Pin selection function

Either serial control or external PWM control can be selected for motor control type with SELECT pin (pin 22).

SELECT	Output state
L	Serial input mode
H	External PWM control mode

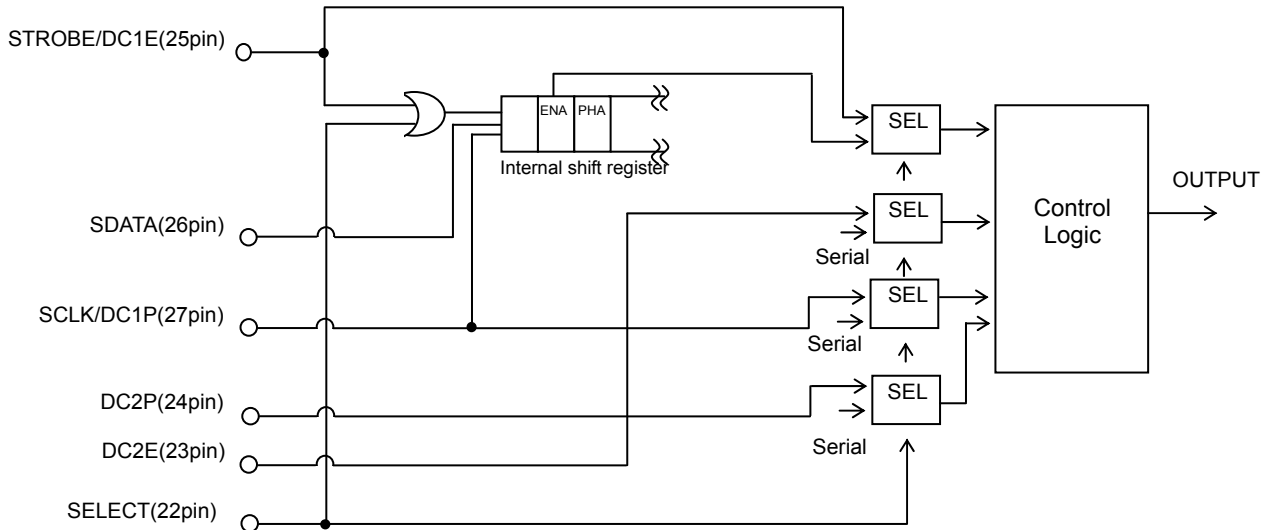

Fig.14 Serial Input Block Diagram

The input/output logic at SELECT = H is as follows.

DC1E/DC2E	Output state
L	Open
H	ACTIVE

DC1P/DC2P	OUTP	OUTM
L	SINK	SOURCE
H	SOURCE	SINK

Procedure of DC motor drive by external PWM control

1)Serial setting

Set the serial by SELECT pin = L. (WORD\_S and WORD\_D setting)

- WORD\_S (see P.7) is a drive parameter for setting OFF\_TIME, BLANK TIME etc.
- WORD\_D (see P.7) is for drive setting to set drive mode of each H-bridge.

When setting WORD\_D (see P.7), make sure that ENABLE signal (ENABLE\_1, ENABLE\_2) of serial bit is L.

If ENABLE signal is H, the motor may operate.

Input of DC2P pin can be either H or L.

2)External PWM drive mode switch

Set external PWM drive mode by SELECT pin = H.

Switch by DC1E (STROBE)/CD2E pin = L when switching SELECT pin.

3)Drive

PHASE, ENABLE pin input signal (DC1E/DC1P/DC2E/DC2P) drives in external PWM mode.

●Serial interface

16-bit 3-linear type serial interface (SDATA (pin 26), SCLK (pin 27), STROBE (pin 25)) is provided to set the operation and the value of current limit. Data are sent to the internal shift register by falling edge of SCLK pin in the area L of STROBE pin. Data of shift register are written in an appropriate address of internal memory of 2\*15 bits by rising edge of STROBE pin according to address data of D15. The input order of serial data is from D0 to D15.

Address data

D15	Word select
0	WORD_S
1	WORD_D

Memory data allocation

BIT	WORD_S	Default	WORD_D	Default
D0	Rohm_Reserve[2]	0	Rohm_Reserve[11]	0
D1	Rohm_Reserve[1]	0	Rohm_Reserve[10]	0
D2	Rohm_Reserve[0]	0	Rohm_Reserve[9]	0
D3	OFF TIME_2[2]	0	Rohm_Reserve[8]	0
D4	OFF TIME_2[1]	0	Rohm_Reserve[7]	0
D5	OFF TIME_2[0]	0	Rohm_Reserve[6]	0
D6	BLANK TIME_2[1]	0	Rohm_Reserve[5]	0
D7	BLANK TIME_2[0]	0	Rohm_Reserve[4]	0
D8	OFF TIME_1[2]	0	Rohm_Reserve[3]	0
D9	OFF TIME_1[1]	0	PWM_MODE_2	0
D10	OFF TIME_1[0]	0	S_PHASE_2	0
D11	BLANK TIME_1[1]	0	S_ENABLE_2	0
D12	BLANK TIME_1[0]	0	PWM_MODE_1	0
D13	MASK SELECT	0	S_PHASE_1	0
D14	SWOFF	0	S_ENABLE_1	0

The timing of serial report writing is shown in the right figure. And the minimum timing of each is as follows:

- A : SDATA setup time..... 10nsec
- B : SDATA hold time..... 10nsec
- C : Setup STROBE to SCLK falling edge.. 50nsec
- D : SCLK low pulse width..... 25nsec
- E : SCLK High pulse width..... 25nsec
- F : Setup SCLK falling edge to STROBE... 25nsec
- G : STROBE pulse width..... 50nsec
- H : Setup RESET to SCLK Rising..... 50μsec

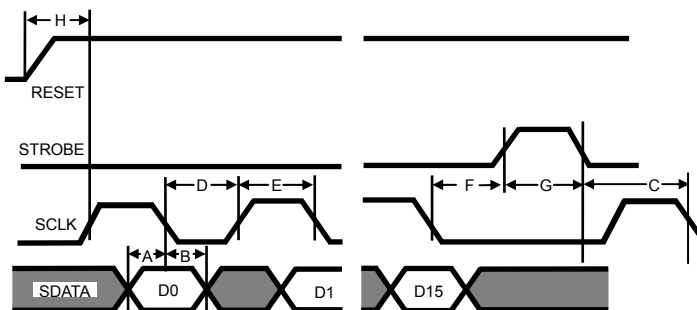

ORESET signal is an internal RESET signal and generated inside IC at the same timing of external RESET output. OSTROBE, SCLK and SDATA signals are input signals through external ASIC.

Fig.15 Serial Signal Input Timing

## ●Serial Port Explanation

### WORD\_S

#### OSWOFF

Set on/off of switching regulator circuit.

0	Switching regulator on
1	Switching regulator off

#### OMASK SELECT

Common mask can be provided to 2-phase H-bridge drive noise mask (BLANK time).

0	Independent mask on single-phase/two-phase.
1	Common mask on single-phase/two-phase.

#### OBLANK TIME

Current-limit comparator monitors RNF pin voltage to set limit to current, but during the period from switching on to BLANK TIME, detection becomes invalid in order to avoid wrong detection caused by spike noise that happens at the time of switching on. See P.8 for details. And during the period from ENABLE signal on to BLANK TIME at switching of PHASE signal, detection becomes invalid as well.

[1]	[0]	BLANK TIME	Unit
0	0	2.0	μs
0	1	3.0	μs
1	0	4.0	μs
1	1	5.0	μs

#### OOFF TIME

Set current decay time.

[2]	[1]	[0]	OFF TIME	Unit
0	0	0	6	μs
0	0	1	8	μs
0	1	0	10	μs
0	1	1	12	μs
1	0	0	14	μs
1	0	1	16	μs
1	1	0	18	μs
1	1	1	20	μs

### WORD\_D

#### OS\_ENABLE\_1/S\_ENABLE\_2

Each bridge on/off signal. Output state is as follows.

	Output state
0	Open
1	ACTIVE

#### OS\_PHASE\_1/S\_PHASE\_2

Set the direction of current of each bridge. Output state is as follows.

	P	M
0	SINK	SOURCE
1	SOURCE	SINK

#### OPWM\_MODE\_1/PWM\_MODE\_2

Set current decay mode in bridge1 and 2. (See page 8 for details about each mode.)

0	FAST DECAY
1	SLOW DECAY

(※)Rohm\_Reserve

Rohm\_Reserve is special mode setting port for inspection at shipment. Especially, if Rohm Reserve [3], [4], [5], [7], [8], [9], [10], [11] is set to H by mistake, malfunction may be caused. Be sure not to set.

●H-bridge Driver Operation

This IC has built-in 2-channel H-bridge driver.  
Each can be used for DC motor drive independently.

1. Current setting

Motor output current-limit value can be set according to the equation below.

$$I_o = (VREF/10) \cdot (1/RNFS) \quad [A]$$

Decide within the range VREF = 0.8V to 3.5V, RNFS = 0.04Ω to 0.35Ω.

2. DECAY mode

Current decay mode can be selected from serial input at the time of motor chopping drive.  
Each mode and timing is as follows.

OSLOW DECAY mode

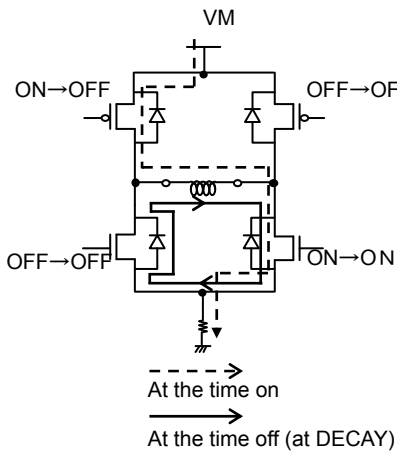

Fig.16 On/Off Timing at SLOW

OFAST DECAY Mode

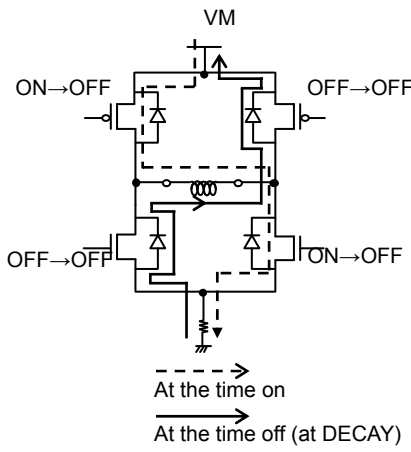

Fig.17 On/Off Timing at FAST

OTiming chart

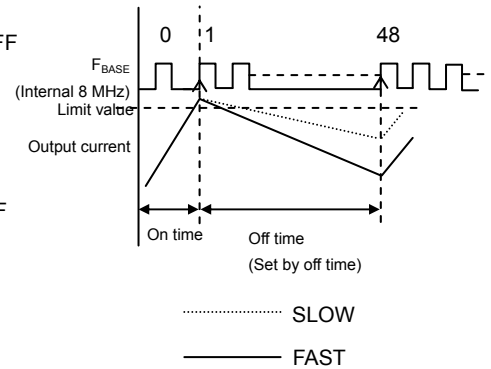

Fig.18 DECAY Mode Timing Chart

3. Protection area for output current value wrong detection

In order to avoid wrong detection of current detection comparator by varistor current element in each motor, current detection are masked at the timing as follows.

①PHASE switching time

②ENABLE on time

③When output is on after OFF\_TIME is finished at the time of current chopping drive

①PHASE switching time

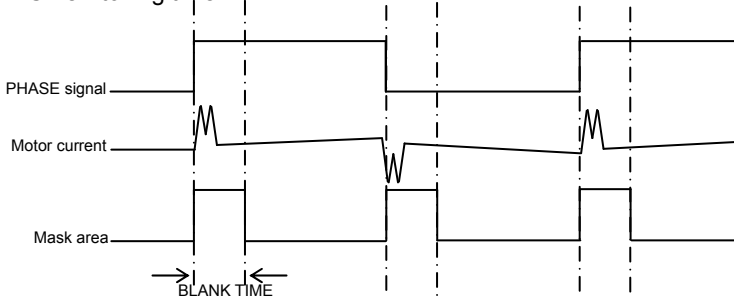

Fig.19 Timing Chart of PHASE Switching Time

②ENABLE on time

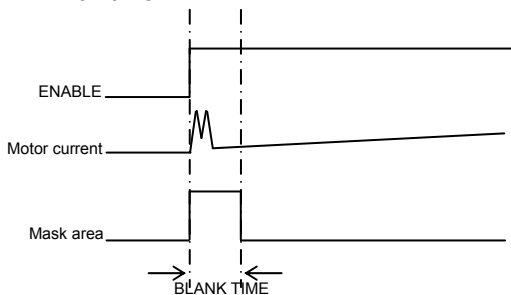

Fig.20 Timing Chart of ENABLE On Timing

③Current chopping driving time

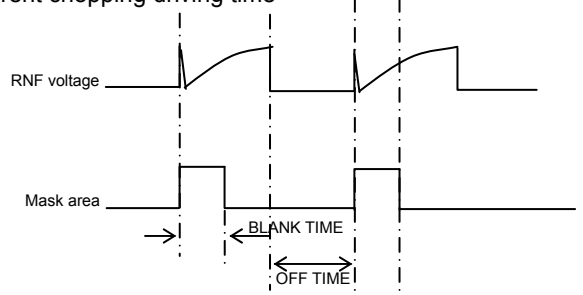

Fig.21 Timing Chart of Current Chopping Driving Time



●Switching regulator operation

○Basic operation

A switching regulator circuit that repeats on/off being synchronized with internal CLK (200 KHz) is built-in. The start up output voltage SWOUT (pin 12) becomes up and run step by step with soft start at the VM power-on ( $V_M \geq V_{MPORH}$ ). The output voltage is determined by the equation below with external resistance.

$$V_{OUTDCDC} = V_{BIAS} \cdot \left\{ \frac{R1 + R2}{R2} \right\} \text{ [V]}$$

The setting should be performed so that the switching regulator output voltage (VOUTDCDC) waveform is optimized within the range of  $V_{OUTDCDC} = 3V$  to  $5V$ ,  $V_{BIAS} = 0.9V$  (Typ.),  $R1 + R2 = 1k\Omega$  to  $10k\Omega$ ,  $C1 = 1,000pF$  to  $10,000pF$ .

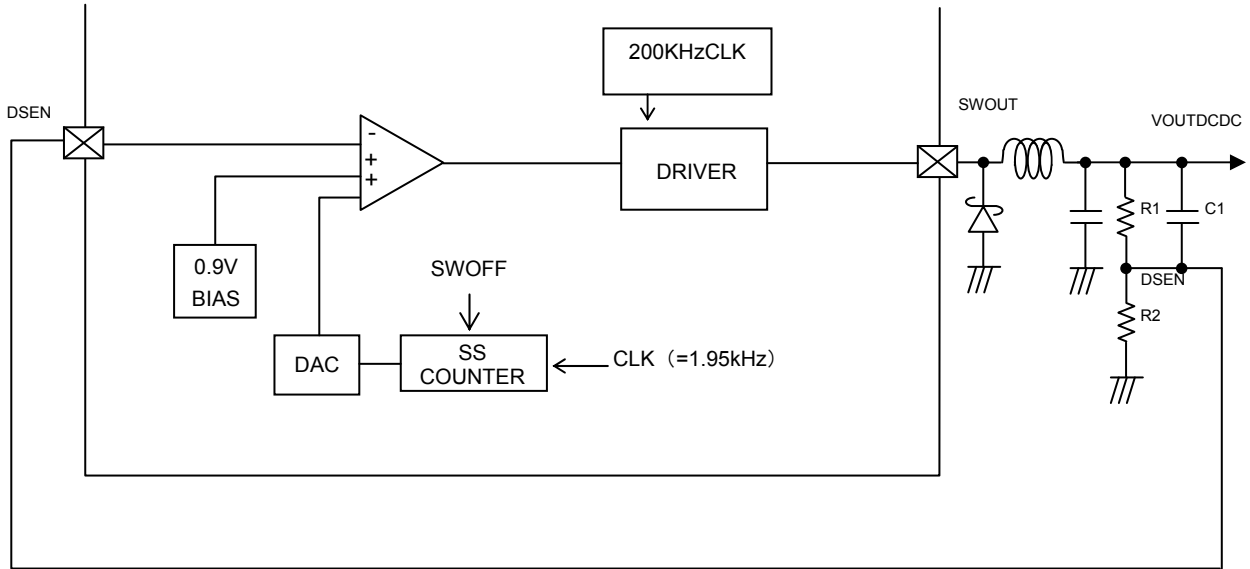

Fig.22 Switching Regulator Block Diagram

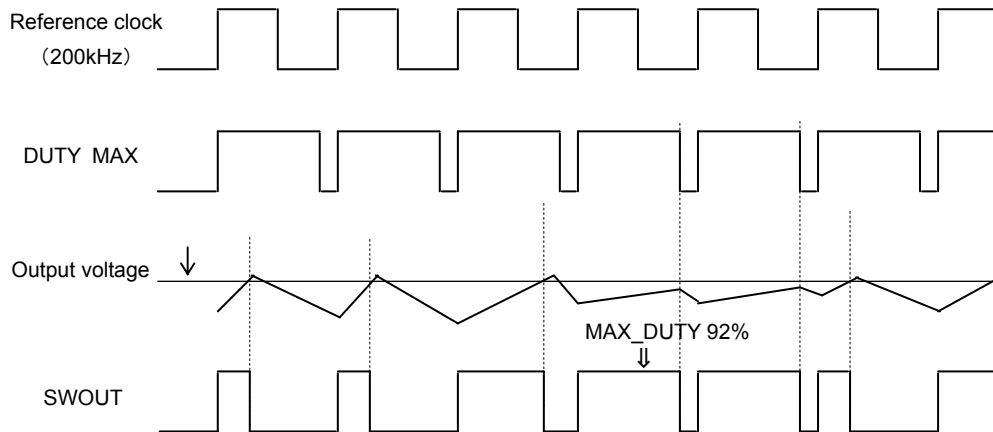

Fig.23 Timing Chart of Switching Regulator Operation

○Soft start

As shown in Fig.24, VOUTDCDC output voltage becomes up and run step by step with soft start at the time of power-on.

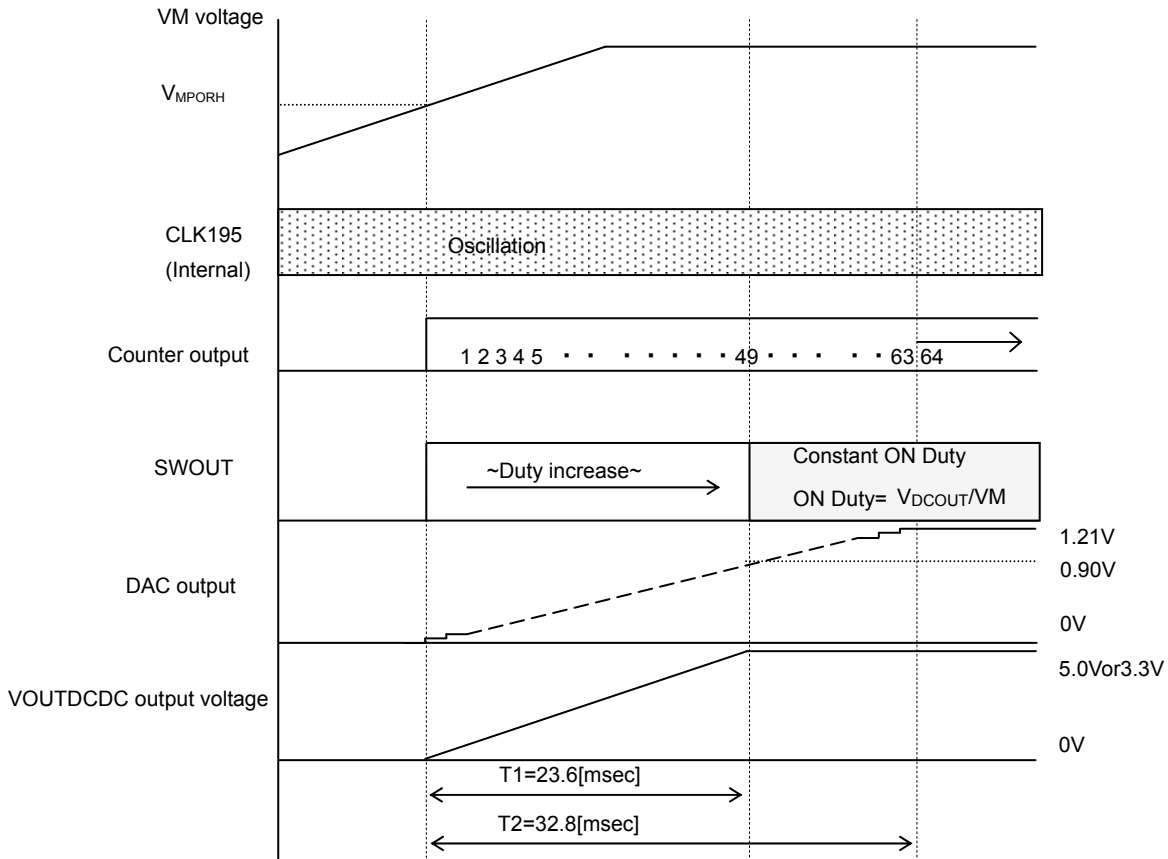

Fig.24 Soft Starting Time Timing Chart

This soft start method is realized by changing comparator positive side voltage that determines output duty of switching regulator to linear using DAC.

Soft start time T1 is constant value regardless of VM voltage.

Soft start time T1=23.6msec(typ.)  
 Count finish time T2=32.8msec(typ.)

○Series regulator operation

Inputting switching regulator output into RIN pin (pin 16) enables to drive series regulator circuit.

At the time of power-on, output voltage start up step by step with soft starting at the same timing as switching regulator circuit. Soft start time is 23.6ms (Typ.).

Regarding external capacitor of ROUT pin (pin 14), it works normally without setting. But switching noise of switching regulator becomes easy to get in due to dragging on board pattern and the like. Pay attention to switching noise.

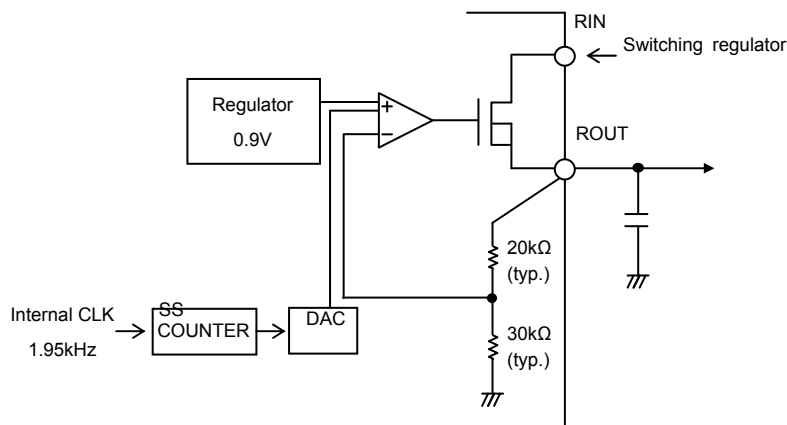

Fig.25 Series Regulator Block Diagram

●Protection function

○Protection circuit function

Overall	Overheating protection
DC motor drive circuit	Overcurrent protection
Switching regulator circuit	Overcurrent protection, output overvoltage protection, output low voltage protection
Series regulator circuit	None

○Operation at protection circuit operation

①Overheating protection . . . All functions are shutout along with junction temperature rise

Thermal shutdown temperature	175°C(typ.)
------------------------------	-------------

	Switching regulator	Series regulator	DC motor	RESET	Re-start
At protection operation	OFF	OFF	OFF	L	Again power-on

②Overcurrent protection (Switching regulator)

	Set current	Mask time	State after operation
$I_{swoc}$	2.6(A)	0.5μsec <sup>(※)</sup>	All function shutout

	Switching regulator	Series regulator	DC motor	RESET	Re-start
Operating	OFF	OFF	OFF	L	Again power-on

③Overcurrent protection (DC motor)

	Set current	Mask time	State after operation
$I_{dcoc}$	3.8(A)	1.5μsec	Shown below

	Switching regulator	Series regulator	DC motor	RESET	Re-start
Operating	ON	ON	OFF	L_PULSE	Serial re-input

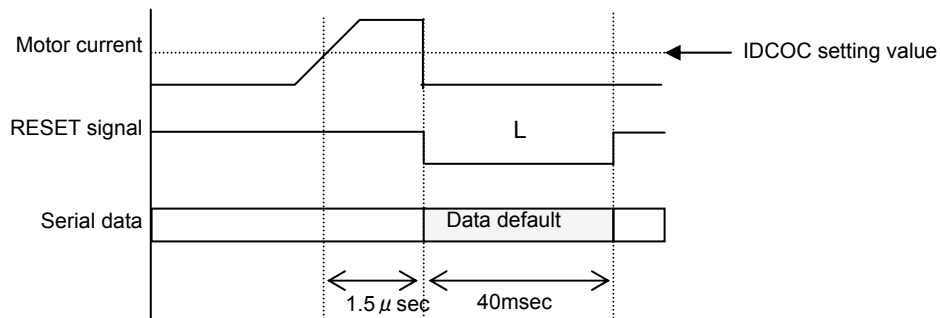

Fig.26 Timing Chart of Motor Overcurrent Protection

(※) If the output pulse of switching regulator is 0.5μs or below, the overcurrent function does not operate even at the time of overcurrent outflow.

④Low voltage protection/overvoltage protection circuit

All functions are shutout on the condition of setting value (+30%, -30%) while DSEN pin voltage (pin 18) of switching regulator circuit is monitored.

	Set voltage	Mask time	State after operation
VSWLV	0.60(V)	10μsec	All function shutout
VSWOH	1.20(V)	10μsec	All function shutout

Note that output overvoltage and output low voltage protection does not work until soft start count finish (32.8 ms, Typ.) at the time of start up of DC/DC power after power-on.

	Switching regulator	Series regulator	DC motor	RESET	Re-start
Operating	OFF	OFF	OFF	L	Again power-on

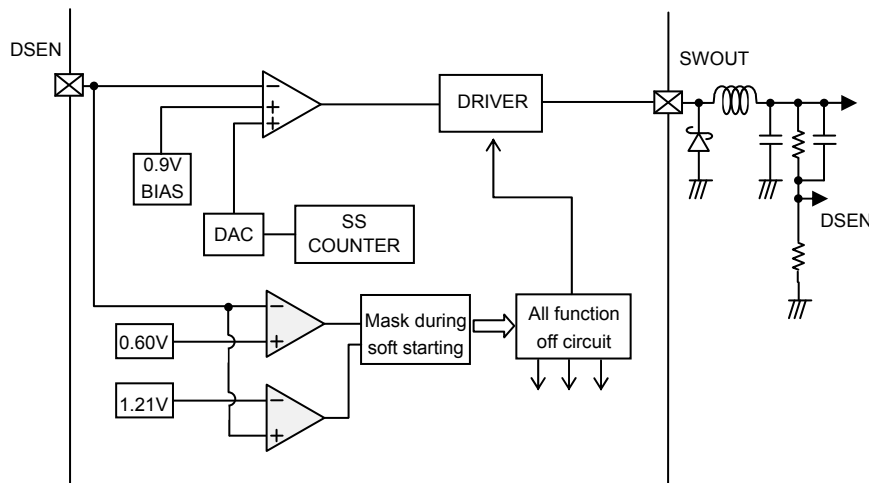

Fig.27 Switching Regulator Block Diagram

○RESET function

Power-on RESET circuit is built-in for VM power source.

H is output at RESET pin through DELAY time of internal counter when power voltage goes up to  $V_{MPORH}$  (6.5 V, Typ.) or higher at the time of power-on. In addition, hysteresis is set up at the time of power-down to output L at RESET pin with  $V_{MPORL}$  (6.1 V, Typ.) And no response time (2.5μs, Typ.) of voltage detection is set in order to avoid wrong detection by sudden power-off. If protection circuits other than overcurrent protection of motor starts operating, RESET is not released if VM power is not on again.

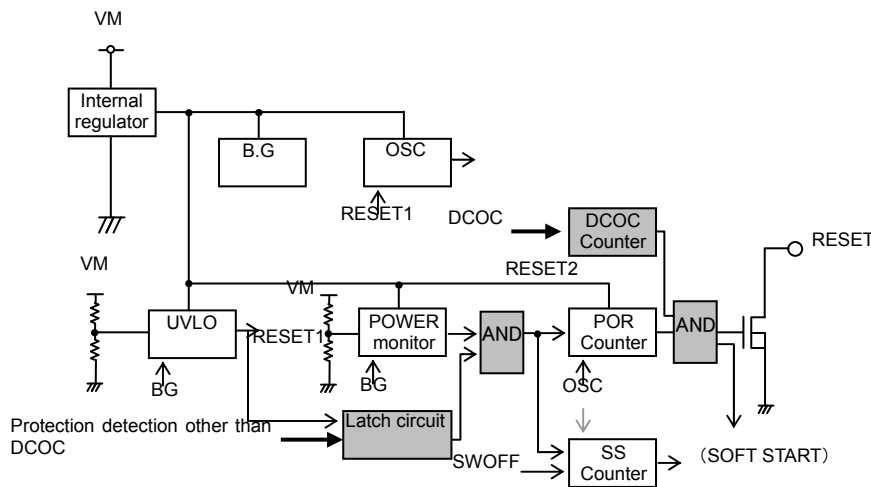
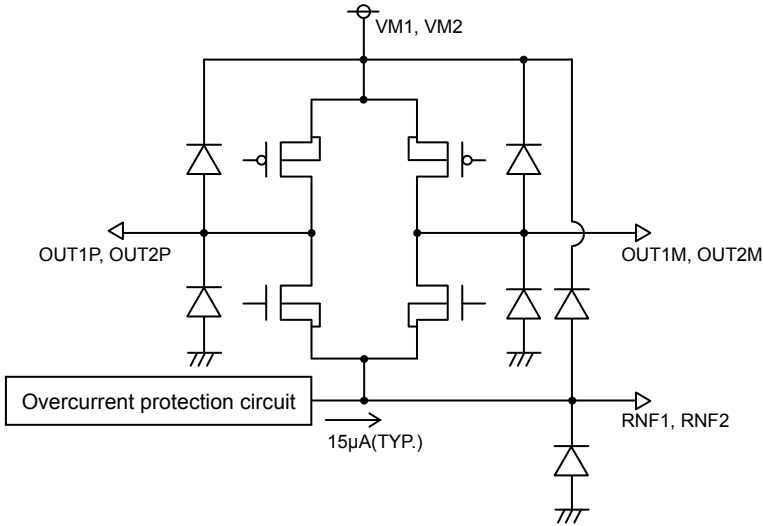

Fig.28 RESET Internal Circuit Block Diagram

● I/O Circuit Diagram

① OUT1P, OUT1M, OUT2P, OUT2M, RNF1 and RNF2



② RNF1S and RNF2S

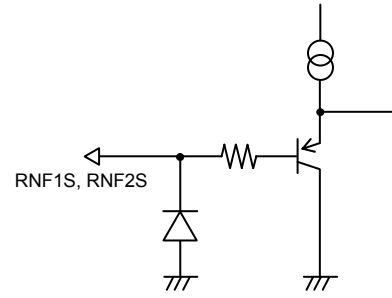

③ SWOUT

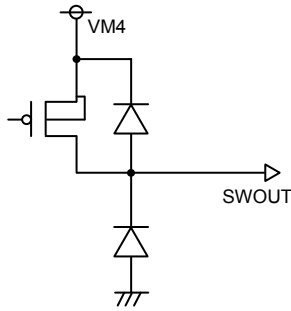

④ RIN and ROUT

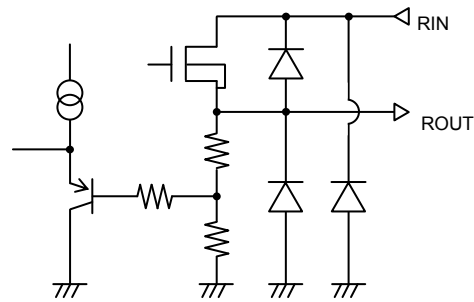

⑤ DSEN

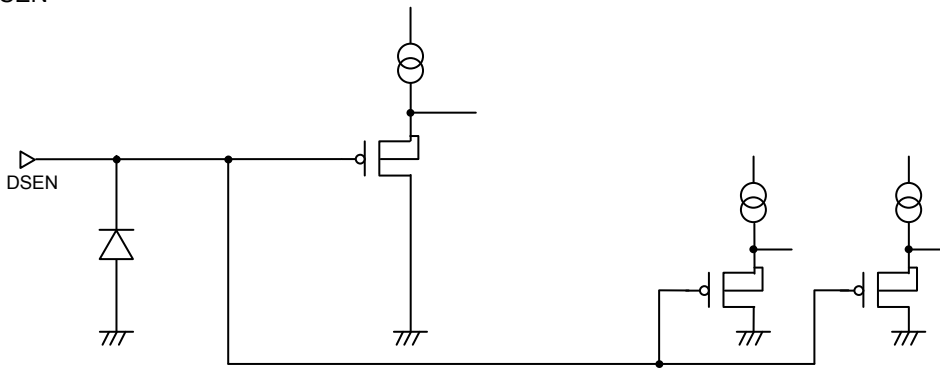

⑥ VREF1 and VREF2

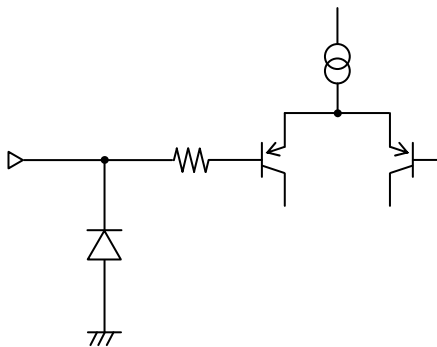

⑦ Logic input

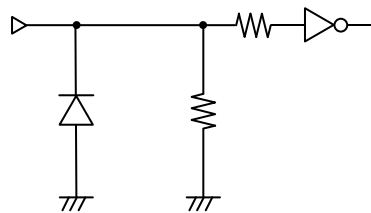

⑧ RESET

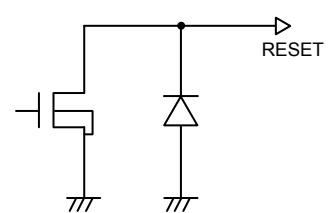

Fig.29 I/O Circuit

### ●Power Dissipation Reduction

On the backside of HTSSOP-B40 package, metal is filled in. Heat dissipation is possible by letting in a through hole from backside. Power dissipation can be improved by providing heat dissipation pattern of copper foil or the like not only on the board surface but also on the backside. The metal on the backside shorts with the backside of IC tip and the potential is GND. Therefore, avoid shorts with other potential than GND, or malfunction or destruction may happen. It is recommended that backside metal should short with GND by soldering.

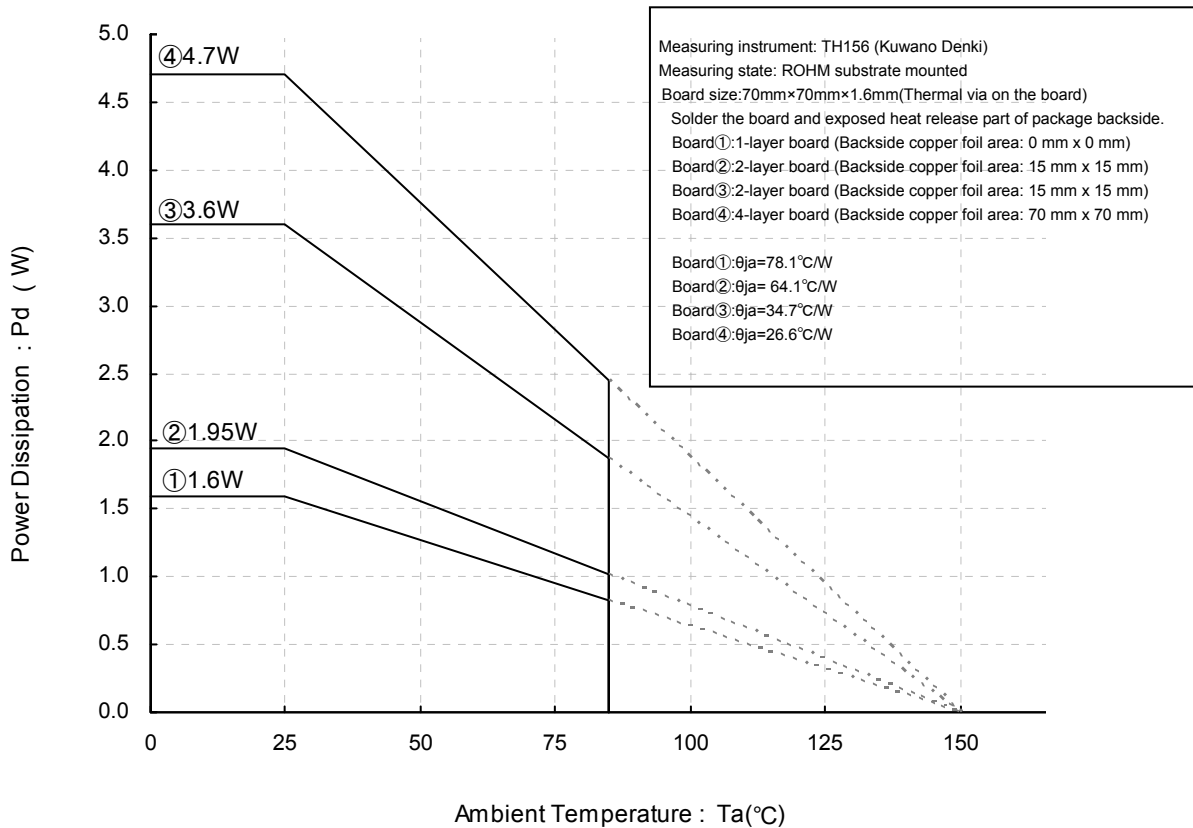

Fig.30 Power Dissipation Reduction

### ●Notes for Use

- 1) Absolute maximum ratings  
 Use of the IC in excess of absolute maximum ratings such as the applied voltage or operating temperature range may result in IC damage. Assumptions should not be made regarding the state of the IC (short mode or open mode) when such damage is suffered. A physical safety measure such as a fuse should be implemented when use of the IC in a special mode where the absolute maximum ratings may be exceeded is anticipated.
- 2) Connecting the power supply connector backward  
 Connecting the power supply connector backwards may result in damage to the IC. Insert external diodes between the power supply and the IC's power supply pins as well as the motor coil to protect against damage from backward connections.
- 3) Power supply lines  
 As return of current regenerated by back EMF of motor happens, take steps such as putting capacitor between power supply and GND as a electric pathway for the regenerated current. Be sure that there is no problem with each property such as emptied capacity at lower temperature regarding electrolytic capacitor to decide capacity value.  
 If the connected power supply does not have sufficient current absorption capacity, regenerative current will cause the voltage on the power supply line to rise, which combined with the product and its peripheral circuitry may exceed the absolute maximum ratings. It is recommended to implement a physical safety measure such as the insertion of a voltage clamp diode between the power supply and GND pins.
- 4) GND potential  
 Ensure a minimum GND pin potential in all operating conditions.

## 5) Setting of heat

Use a thermal design that allows for a sufficient margin in light of the power dissipation ( $P_d$ ) in actual operating conditions. BD64550EFV expose its frame of the backside of package. Note that this part is assumed to use after providing heat dissipation treatment to improve heat dissipation efficiency. Try to occupy as wide as possible with heat dissipation pattern not only on the board surface but also the backside.

## 6) Pin short and mistake fitting

Use caution when orienting and positioning the IC for mounting on printed circuit boards. Improper mounting may result in damage to the IC. Shorts between output pins or between output pins and the power supply and GND pins caused by the presence of a foreign object may result in damage to the IC.

## 7) Actions in strong magnetic field

Use caution when using the IC in the presence of a strong magnetic field as doing so may cause the IC to malfunction.

## 8) ASO

When using the IC, set the output transistor so that it does not exceed absolute maximum ratings or ASO.

## 9) Thermal shutdown circuit

The IC has a built-in thermal shutdown circuit (TSD circuit). If the chip temperature becomes  $T_{jmax}=150^{\circ}\text{C}$ , and higher, coil output to the motor and regulator output will be OFF, and reset output will be L. The TSD circuit is designed only to shut the IC off to prevent runaway thermal operation. It is not designed to protect or indemnify peripheral equipment. Do not use the TSD function to protect peripheral equipment.

## 10) Testing on application boards

When testing the IC on an application board, connecting a capacitor to a pin with low impedance subjects the IC to stress. Always discharge capacitors after each process or step. Ground the IC during assembly steps as an antistatic measure, and use similar caution when transporting or storing the IC. Always turn the IC's power supply off before connecting it to or removing it from a jig or fixture during the inspection process.

## 11) Regarding input pin of the IC

This monolithic IC contains P+ isolation and P substrate layers between adjacent elements in order to keep them isolated/N junctions are formed at the intersection of these P layers with the N layers of other elements to create a variety of parasitic elements. For example, when a resistor and transistor are connected to pins as shown in Fig. 31,

○The P/N junction functions as a parasitic diode

when  $\text{GND} > (\text{Pin A})$  for the resistor or  $\text{GND} > (\text{Pin B})$  for the transistor (NPN).

○Similarly, when  $\text{GND} > (\text{Pin B})$  for the transistor (NPN), the parasitic diode described above combines with the N layer of other adjacent elements to operate as a parasitic NPN transistor.

The formation of parasitic elements as a result of the relationships of the potentials of different pins is an inevitable result of the IC's architecture. The operation of parasitic elements can cause interference with circuit operation as well as IC malfunction and damage. For these reasons, it is necessary to use caution so that the IC is not used in a way that will trigger the operation of parasitic elements, such as by the application of voltages lower than the GND (P substrate) voltage to input pins.

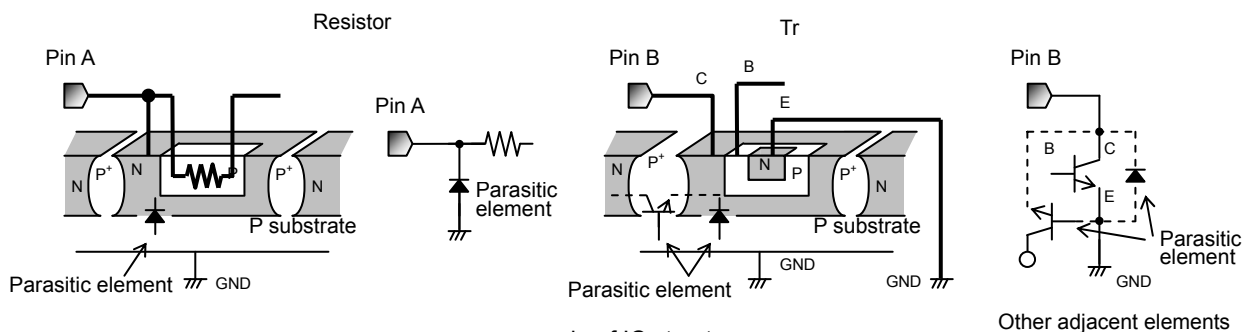
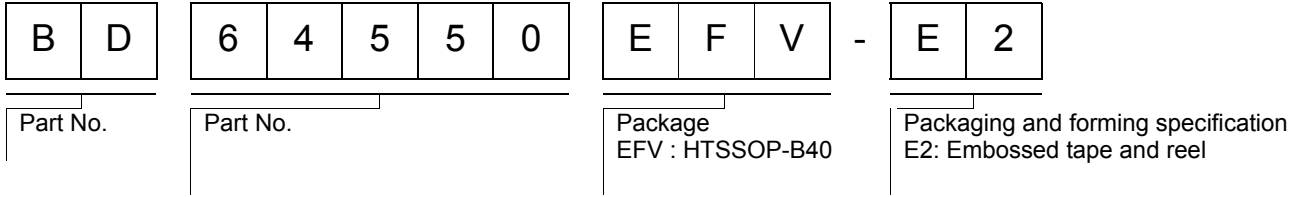

Fig.31 example of IC structure

## 12) Ground Wiring Pattern

When using both small signal and large current GND patterns, it is recommended to isolate the two ground patterns, placing a single ground point at the application's reference point so that the pattern wiring resistance and voltage variations caused by large currents do not cause variations in the small signal ground voltage. Be careful not to change the GND wiring pattern of any external components, either.

●Ordering Part Number



HTSSOP-B40

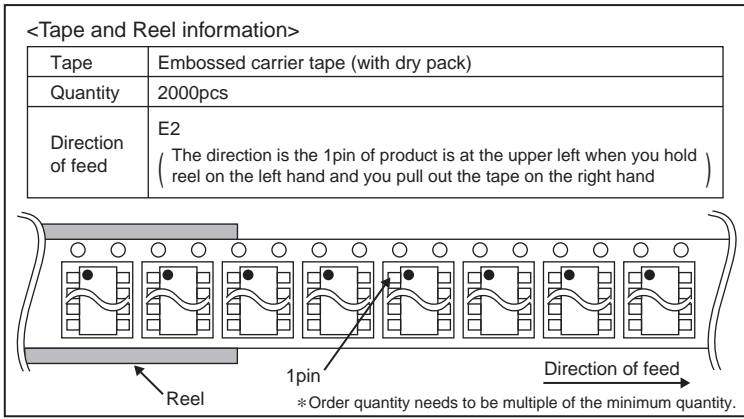
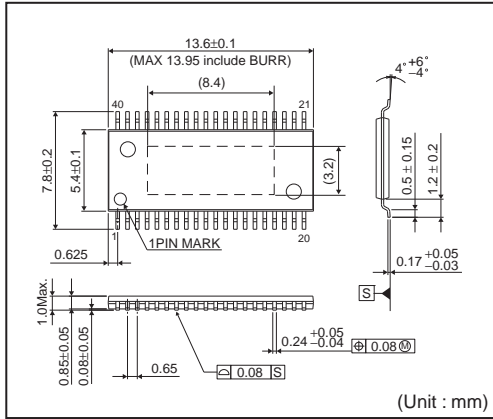



## Notes

No copying or reproduction of this document, in part or in whole, is permitted without the consent of ROHM Co.,Ltd.

The content specified herein is subject to change for improvement without notice.

The content specified herein is for the purpose of introducing ROHM's products (hereinafter "Products"). If you wish to use any such Product, please be sure to refer to the specifications, which can be obtained from ROHM upon request.

Examples of application circuits, circuit constants and any other information contained herein illustrate the standard usage and operations of the Products. The peripheral conditions must be taken into account when designing circuits for mass production.

Great care was taken in ensuring the accuracy of the information specified in this document. However, should you incur any damage arising from any inaccuracy or misprint of such information, ROHM shall bear no responsibility for such damage.

The technical information specified herein is intended only to show the typical functions of and examples of application circuits for the Products. ROHM does not grant you, explicitly or implicitly, any license to use or exercise intellectual property or other rights held by ROHM and other parties. ROHM shall bear no responsibility whatsoever for any dispute arising from the use of such technical information.

The Products specified in this document are intended to be used with general-use electronic equipment or devices (such as audio visual equipment, office-automation equipment, communication devices, electronic appliances and amusement devices).

The Products specified in this document are not designed to be radiation tolerant.

While ROHM always makes efforts to enhance the quality and reliability of its Products, a Product may fail or malfunction for a variety of reasons.

Please be sure to implement in your equipment using the Products safety measures to guard against the possibility of physical injury, fire or any other damage caused in the event of the failure of any Product, such as derating, redundancy, fire control and fail-safe designs. ROHM shall bear no responsibility whatsoever for your use of any Product outside of the prescribed scope or not in accordance with the instruction manual.

The Products are not designed or manufactured to be used with any equipment, device or system which requires an extremely high level of reliability the failure or malfunction of which may result in a direct threat to human life or create a risk of human injury (such as a medical instrument, transportation equipment, aerospace machinery, nuclear-reactor controller, fuel-controller or other safety device). ROHM shall bear no responsibility in any way for use of any of the Products for the above special purposes. If a Product is intended to be used for any such special purpose, please contact a ROHM sales representative before purchasing.

If you intend to export or ship overseas any Product or technology specified herein that may be controlled under the Foreign Exchange and the Foreign Trade Law, you will be required to obtain a license or permit under the Law.



Thank you for your accessing to ROHM product informations.  
More detail product informations and catalogs are available, please contact us.

## ROHM Customer Support System

<http://www.rohm.com/contact/>

Компания «Life Electronics» занимается поставками электронных компонентов импортного и отечественного производства от производителей и со складов крупных дистрибьюторов Европы, Америки и Азии.

С конца 2013 года компания активно расширяет линейку поставок компонентов по направлению коаксиальный кабель, кварцевые генераторы и конденсаторы (керамические, пленочные, электролитические), за счёт заключения дистрибьюторских договоров

Мы предлагаем:

- Конкурентоспособные цены и скидки постоянным клиентам.
- Специальные условия для постоянных клиентов.
- Подбор аналогов.
- Поставку компонентов в любых объемах, удовлетворяющих вашим потребностям.
- Приемлемые сроки поставки, возможна ускоренная поставка.
- Доставку товара в любую точку России и стран СНГ.
- Комплексную поставку.
- Работу по проектам и поставку образцов.
- Формирование склада под заказчика.
- Сертификаты соответствия на поставляемую продукцию (по желанию клиента).
- Тестирование поставляемой продукции.
- Поставку компонентов, требующих военную и космическую приемку.
- Входной контроль качества.
- Наличие сертификата ISO.

В составе нашей компании организован Конструкторский отдел, призванный помогать разработчикам, и инженерам.

Конструкторский отдел помогает осуществить:

- Регистрацию проекта у производителя компонентов.
- Техническую поддержку проекта.
- Защиту от снятия компонента с производства.
- Оценку стоимости проекта по компонентам.
- Изготовление тестовой платы монтаж и пусконаладочные работы.



Тел: +7 (812) 336 43 04 (многоканальный)

Email: [org@lifeelectronics.ru](mailto:org@lifeelectronics.ru)