

Data Sheet

AS01608MS-SP16-WP-R

PUI Audio’s **Mobile Series** line of speakers and receivers is designed for cutting-edge applications such as smart watches and pendants, Wi-Fi enabled security devices and action cameras, mobile radios and smart phones, as well as IoT devices. Each **Mobile Series** product features an IP67-rated face for protection against dust and water ingress.

The eight ohm 16mm x 9mm **AS01608MS-SP16-WP-R** speaker is designed for high fidelity audio reproduction in the thinnest size possible—only 3mm thick! Solder pads allow for lead wire connection.

Features:

- PEEK diaphragm for flat frequency response
- 90 dB output (2.37V @ 10cm)
- High-energy neodymium motor
- Only 3 mm thick
- Dustproof and waterproof IP67-rated face

Specifications

Parameters	Values	Units
Rated Input Power	0.7	Watts
Max Input Power	1	Watts
Impedance	8 ± 20%	Ohms
Sensitivity (SPL @ 2.37V/10cm) Average of 0.8, 1.0, 1.5, and 2.0 kHz in 1cc enclosure	90 ± 3	dB
Resonant Frequency (in 1cc enclosure)	950 ± 20%	Hz
Frequency Range	500 ~ 20,000	Hz
Frame Material	PPA	-
Magnet Material	NdFeB	-
Weight	1.2	Grams
Environmental Protection Rating	IP67	-

Specifications (continued)

Buzz, Rattle, etc.	Should not be audible with 2V sine sweep from 500 Hz to 10 kHz installed in a 1cc enclosure	-
Polarity	When positive voltage is applied to the positive terminal, the diaphragm will move outward	-
Storage Temperature	-40 ~ +85	°C
Operating Temperature	-20 ~ +70	°C

Measurement Method (measured with 2V, Temperature: 15 ~ 35°C, Relative Humidity: 45%~85%) Speaker Measurement Circuit

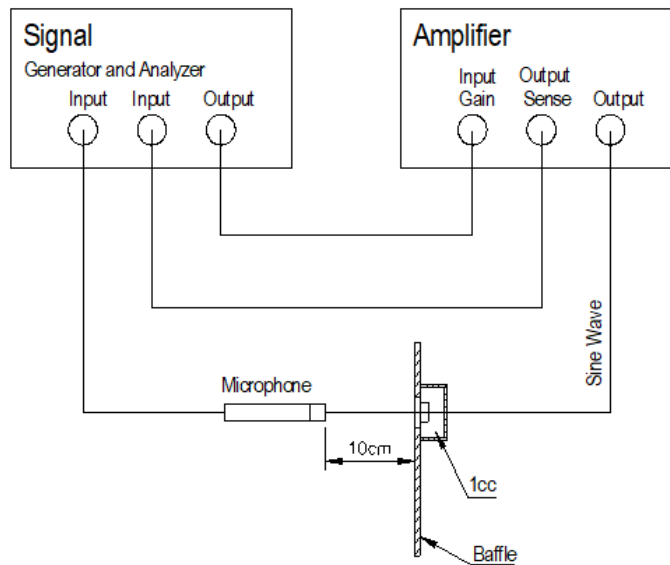

Frequency Response (measured with 2V @ 10cm in 1cc enclosure)

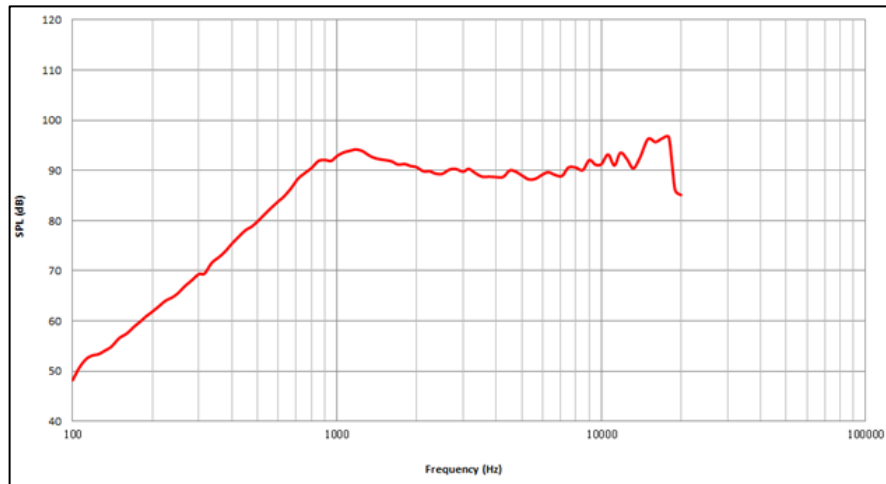

Impedance Response (Measured with speaker in a 1cc enclosure)

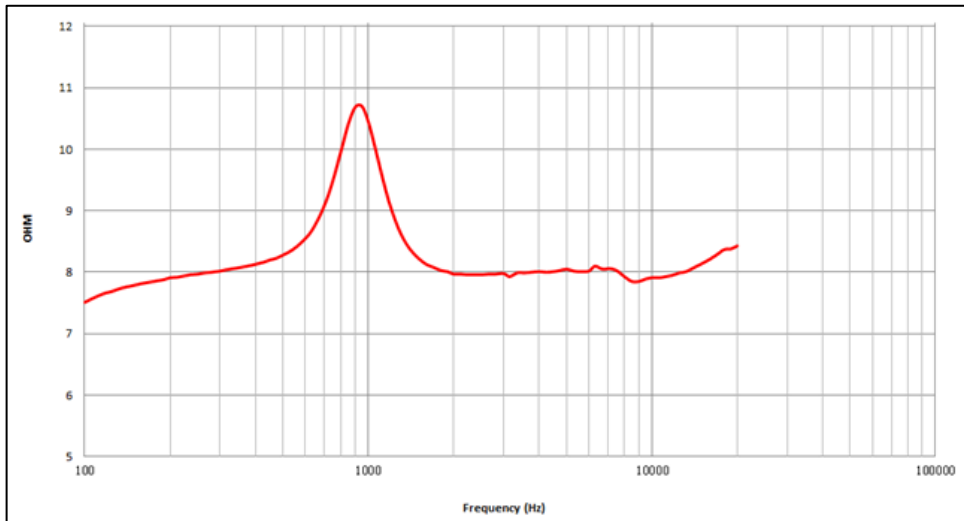

Reliability Testing

Type of Test	Test Specifications
High Temperature Test	96 hours at +85°C ± 3°C followed by three hours in normal room temperature
Low Temperature Test	96 hours at -40°C ± 3°C followed by three hours in normal room temperature
Humidity Test	96 hours at +55°C ± 3°C with relative humidity at 95% in accordance with IEC 68-2-67
Temperature Cycle Testing	The part shall be subjected to 20 cycles using the following procedure: Low temperature: -40°C±3°C High temperature:+85°C±3°C Cycle: 30 mins at High, 10 seconds High to Low, 30 mins at Low, 10 seconds minutes Low to High
Vibration Test	10 to 55 to 10 Hz sine sweep, per minute @ 1.5mm amplitude 2 hours in each axis X, Y, and Z
Drop Test	Mount speaker to 150g fixture, drop fixture 1.5 meters, twice per side and twice for each corner
Load Test	DUTs shall be tested under each specified climatic condition for a continuous period of 100 hours at rated noise power. Speakers mounted in a 1cc back cavity; simulated program signal (IEC 268-1) with crest factor of 1.8~2.2 , in rated frequency range; high pass 12dB/Oct or steeper, cut off at 850Hz. Refer to IEC 268-5

After each test, the speaker's SPL shall be ±3 dB of the original SPL

Dimensions (Bottom contact is positive on the far right drawing below)

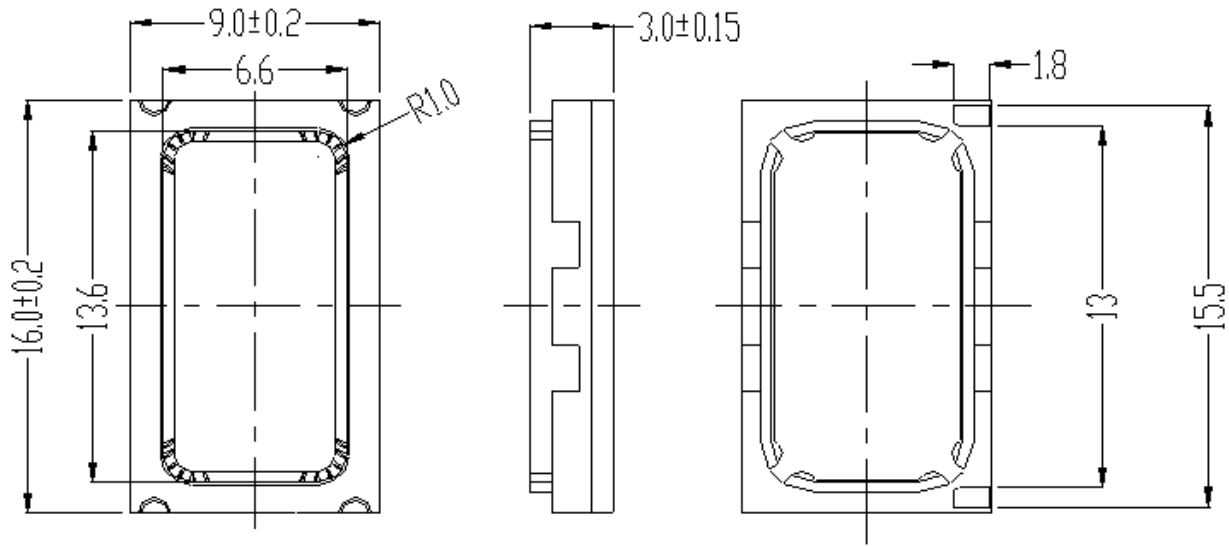

Packaging

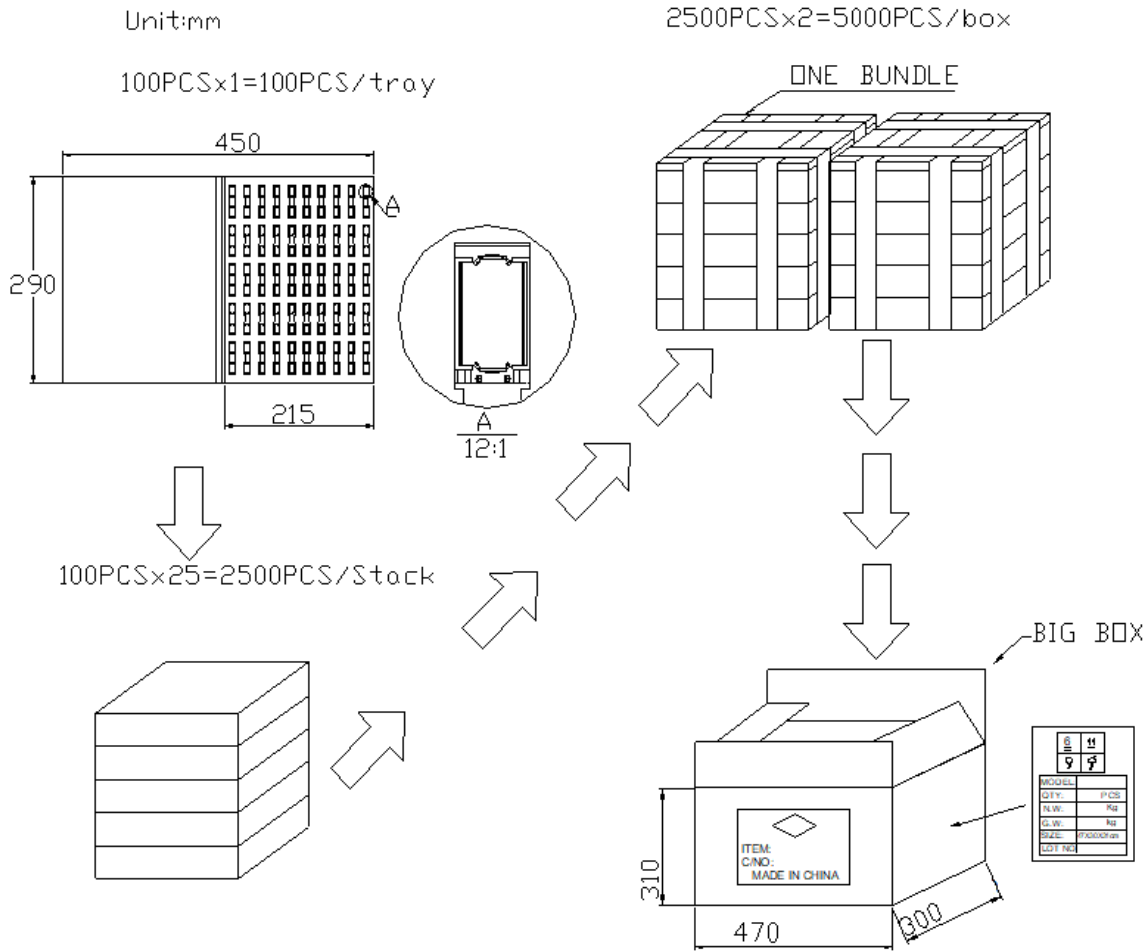

Unless otherwise specified, tolerance:±10(unit:mm)

Specifications Revisions

Revision	Description	Date
-	Released from Engineering	11/20/2017

Note:

1. Unless otherwise specified:
 - A. All dimensions are in millimeters.
 - B. Default tolerances are $\pm 0.5\text{mm}$ and angles are $\pm 3^\circ$.
2. Specifications subject to change or withdrawal without notice.
3. This part is RoHS 2011/65/EU Compliant.

Компания «Life Electronics» занимается поставками электронных компонентов импортного и отечественного производства от производителей и со складов крупных дистрибьюторов Европы, Америки и Азии.

С конца 2013 года компания активно расширяет линейку поставок компонентов по направлению коаксиальный кабель, кварцевые генераторы и конденсаторы (керамические, пленочные, электролитические), за счёт заключения дистрибьюторских договоров

Мы предлагаем:

- Конкурентоспособные цены и скидки постоянным клиентам.
- Специальные условия для постоянных клиентов.
- Подбор аналогов.
- Поставку компонентов в любых объемах, удовлетворяющих вашим потребностям.
- Приемлемые сроки поставки, возможна ускоренная поставка.
- Доставку товара в любую точку России и стран СНГ.
- Комплексную поставку.
- Работу по проектам и поставку образцов.
- Формирование склада под заказчика.
- Сертификаты соответствия на поставляемую продукцию (по желанию клиента).
- Тестирование поставляемой продукции.
- Поставку компонентов, требующих военную и космическую приемку.
- Входной контроль качества.
- Наличие сертификата ISO.

В составе нашей компании организован Конструкторский отдел, призванный помогать разработчикам, и инженерам.

Конструкторский отдел помогает осуществить:

- Регистрацию проекта у производителя компонентов.
- Техническую поддержку проекта.
- Защиту от снятия компонента с производства.
- Оценку стоимости проекта по компонентам.
- Изготовление тестовой платы монтаж и пусконаладочные работы.



Тел: +7 (812) 336 43 04 (многоканальный)

Email: org@lifeelectronics.ru