

FEATURES

- Standard 7x5mm Surface Mount Footprint
- HCMOS/TTL Compatible Output
- Frequency Range 1.5 – 77.76 MHz
- Frequency Stability, ± 50 ppm Standard (± 25 ppm and ± 20 ppm available)
- +3.3Vdc or +5.0Vdc Operation
- Operating Temperature to -40°C to $+85^{\circ}\text{C}$
- Output Enable Standard
- Low Phase Jitter, *NON-Multiplied*
- Tape & Reel Packaging
- **RoHS/Green Compliant**

DESCRIPTION

The Model 357 is a ceramic packaged Voltage Controlled oscillator offering reduced size and enhanced stability. The small size means it is perfect for any application. The enhanced stability means it is the perfect choice for today's communications applications that require tight frequency control.



ORDERING INFORMATION

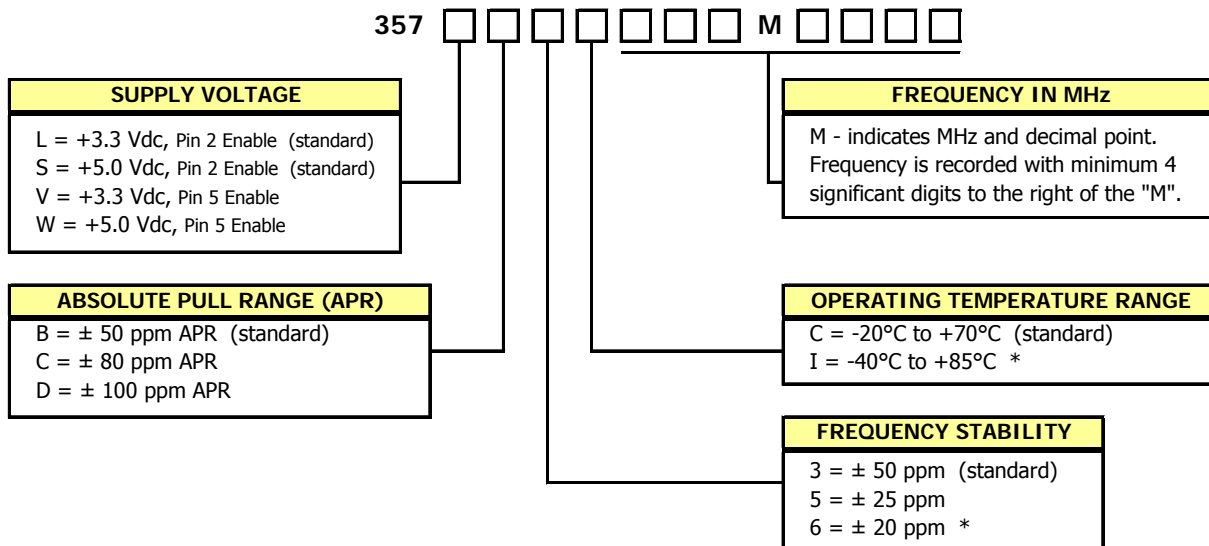

Example Part Number: 357LB3C019M4400

ELECTRICAL CHARACTERISTICS

	PARAMETER	SYMBOL	CONDITIONS	MIN	TYP	MAX	UNIT
Absolute Maximums	Maximum Supply Voltage	V_{CC}	-	-0.5	-	7.0	V
	Maximum Control Voltage	V_C	-	-0.5	-	V_{CC}	V
	Storage Temperature	T_{STG}	-	-55	-	125	°C
	Frequency Range	f_0	-	1.5	-	77.76	MHz
	Frequency Stability (See Note 1 and Ordering Information)	$\Delta f/f_0$	-	-	-	20, 25 or 50	± ppm
	Absolute Pull Range (See Note 2 and Ordering Information)	APR	-	50, 80 or 100	-	-	± ppm
	Operating Temperature Commercial Industrial	T_A	-	-20 -40	25	70 85	°C
Electrical and Waveform Parameters	Supply Voltage Model 357S, 357W Model 357L, 357V	V_{CC}	± 10 %	4.5 2.97	5.0 3.3	5.5 3.63	V
	Supply Current	I_{CC}	$C_L = 15$ pF 1.5 MHz to 20 MHz 20.1 MHz to 40 MHz 40.1 MHz to 60 MHz 60.1 MHz to 80 MHz	- - - -	5 8 10 12	20 30 40 45	mA
	Output Load	C_L	-	-	-	30	pF
	Control Voltage Model 357S, 357W Model 357L, 357V	V_C	$V_{CC} = 5.0V$ $V_{CC} = 3.3V$	0.5 0.3	2.5 1.65	4.5 3.0	V
	Frequency Deviation	Δf	25°C at Time of Shipment, over V_C range	-	135	-	± ppm
	Linearity Best Straight Line Fit	L	< 52 MHz > 52 MHz	- -	5 8	10 15	%
	Output Duty Cycle	SYM	@ 50% Level	45	-	55	%
	Output Voltage Levels Logic '1' Level Logic '0' Level	V_{OH} V_{OL}	CMOS Load CMOS Load	90% V_{CC} -	- -	- 10% V_{CC}	V
	Output Current Levels Logic '1' Level Logic '0' Level	I_{OH} I_{OL}	CMOS Load CMOS Load	- -	- -	-14 14	mA
	Rise and Fall Time	T_{R}, T_F	@ 10% - 90% Levels	-	3.5	5.0	ns
	Input Impedance	Z_C	-	50	-	-	kOhms
	Transfer Function	-	-	-	Positive	-	-
	Start Up Time	T_S	Application of V_{CC}	-	-	10	ms
	Modulation Roll-off	-	@ -3dB	10	-	-	kHz
	Phase Jitter	t_{jms}	Bandwidth 12 kHz - 20 MHz	-	-	1	ps RMS
	Enable Function Enable Input Voltage Disable Input Voltage Enable Time	V_{IH} V_{IL} T_{PLZ}	Pin 2 or Pin 5 Logic '1', Output Enabled Pin 2 or Pin 5 Logic '0', Output Disabled Pin 2 or Pin 5 Logic '1'	2.5 - -	- - -	- 0.5 100	V V ns

Notes:

- Inclusive of initial tolerance at time of shipment, changes in supply voltage, load, temperature and 10 year aging at an average operating temperature of +40 °C.
- Minimum guaranteed frequency shift from f_0 over variations in temperature, aging, power supply and load at an average operating temperature of +40°C for 10 years.

SINGLE SIDE BAND PHASE NOISE (typical maximum)

Frequency Offset	Phase Noise (dBc/Hz) *	Frequency Offset	Phase Noise (dBc/Hz) *
10 Hz	-60	10k Hz	-130
100 Hz	-90	100k Hz	-150
1k Hz	-112	≥ 100k Hz	-150

* Results may vary depending on frequency.

CMOS/TTL OUTPUT WAVEFORM

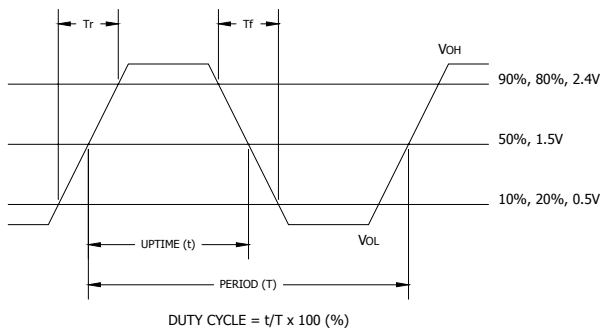

D.U.T. PIN ASSIGNMENTS

PIN	SYMBOL	DESCRIPTION
1	V _C	Control Voltage
2	EOH or N.C.	Enable or No Connect
3	GND	Circuit & Package Ground
4	Output	RF Output
5	N.C. or EOH	No Connect or Enable
6	V _{CC}	Supply Voltage

TEST CIRCUIT, CMOS LOAD

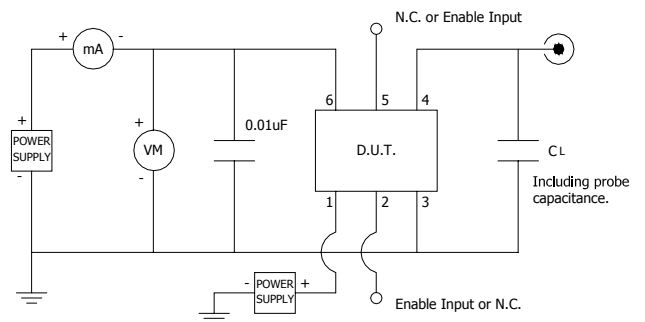

ENABLE TRUTH TABLE

PIN 2 or PIN 5	PIN 4
Logic '1'	Output
Open	Output
Logic '0'	High Imp.

MECHANICAL SPECIFICATIONS

PACKAGE DRAWING

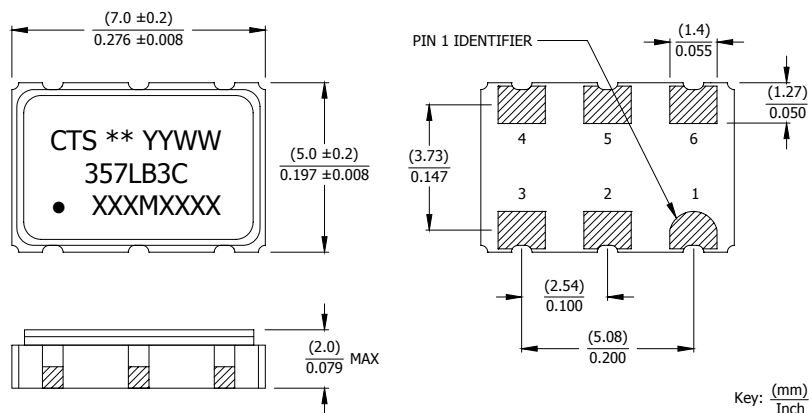

MARKING INFORMATION

- ** - Manufacturing Site Code.
- YYWW - Date code, YY - year, WW - week.
- Truncated CTS part number.
- XXXMXXXX - Frequency marked with 4 significant digits after the 'M'.

NOTES

- Termination pads (e4), barrier-plating is nickel (Ni) with gold (Au) flash plate.
- Reflow conditions per JEDEC J-STD-020.

SUGGESTED SOLDER PAD GEOMETRY

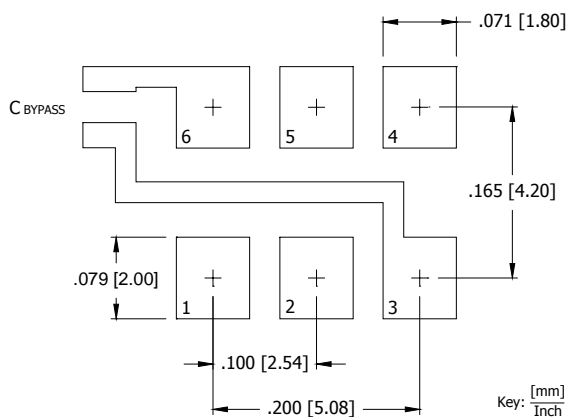

C_{BYPASS} should be ≥ 0.01 uF.

SUGGESTED REFLOW PROFILE

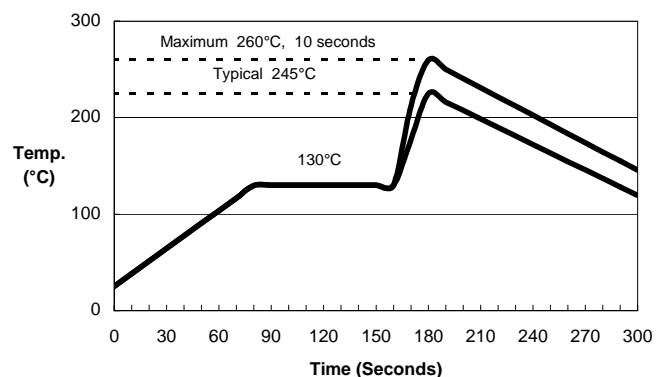

TAPE AND REEL INFORMATION

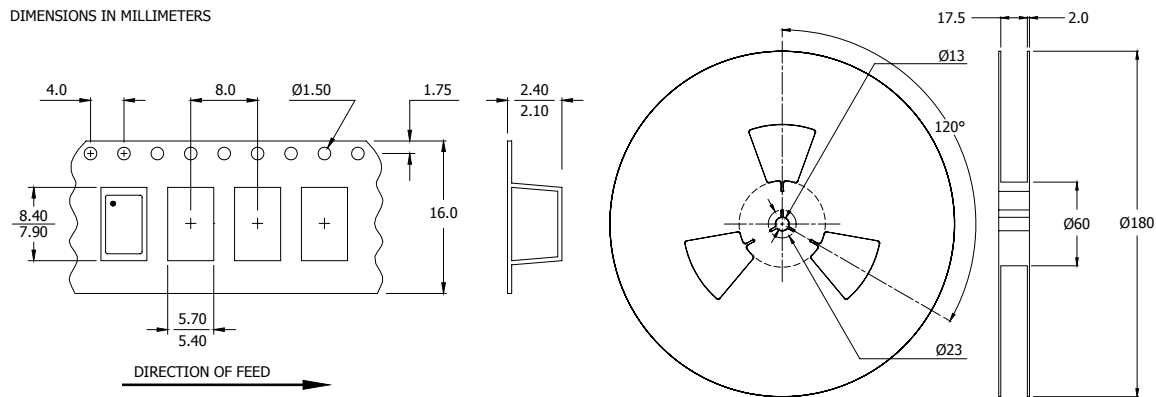

Device quantity is 1,000 pieces per 180mm reel.

ENVIRONMENTAL SPECIFICATIONS

Temperature Cycle:	400 cycles from -55°C to $+125^{\circ}\text{C}$, 10 minute dwell at each temperature, 1 minute transfer time between temperatures.
Mechanical Shock:	1,500g's, 0.5mS duration, 1/2 sinewave, 3 shocks each direction along 3 mutually perpendicular planes (18 total shocks).
Sinusoidal Vibration:	0.06 inches double amplitude, 10 to 55 Hz and 20g's, 55 to 2,000 Hz, 3 cycles each in 3 mutually perpendicular planes (9 times total).
Gross Leak:	No leak shall appear while immersed in an FC40 or equivalent liquid at $+125^{\circ}\text{C}$ for 20 seconds.
Fine Leak:	Mass spectrometer leak rates less than 2×10^{-8} ATM cc/sec air equivalent.
Resistance to Solder Heat:	Product must survive 3 reflows of $+260^{\circ}\text{C}$ peak, 10 seconds maximum.
High Temperature Operating Bias:	2,000 hours at $+125^{\circ}\text{C}$, maximum bias, disregarding frequency shift.
Frequency Aging:	1,000 hours at $+85^{\circ}\text{C}$, full bias, less than ± 5 ppm shift.
Moisture Sensitivity Level:	Level 1 per JEDEC J-STD-020.

QUALITY AND RELIABILITY

Quality systems meet or exceed the requirements of ISO 9000:2000 standards.

Компания «Life Electronics» занимается поставками электронных компонентов импортного и отечественного производства от производителей и со складов крупных дистрибьюторов Европы, Америки и Азии.

С конца 2013 года компания активно расширяет линейку поставок компонентов по направлению коаксиальный кабель, кварцевые генераторы и конденсаторы (керамические, пленочные, электролитические), за счёт заключения дистрибьюторских договоров

Мы предлагаем:

- Конкуренспособные цены и скидки постоянным клиентам.
- Специальные условия для постоянных клиентов.
- Подбор аналогов.
- Поставку компонентов в любых объемах, удовлетворяющих вашим потребностям.
- Приемлемые сроки поставки, возможна ускоренная поставка.
- Доставку товара в любую точку России и стран СНГ.
- Комплексную поставку.
- Работу по проектам и поставку образцов.
- Формирование склада под заказчика.
- Сертификаты соответствия на поставляемую продукцию (по желанию клиента).
- Тестирование поставляемой продукции.
- Поставку компонентов, требующих военную и космическую приемку.
- Входной контроль качества.
- Наличие сертификата ISO.

В составе нашей компании организован Конструкторский отдел, призванный помогать разработчикам, и инженерам.

Конструкторский отдел помогает осуществить:

- Регистрацию проекта у производителя компонентов.
- Техническую поддержку проекта.
- Защиту от снятия компонента с производства.
- Оценку стоимости проекта по компонентам.
- Изготовление тестовой платы монтаж и пусконаладочные работы.



Тел: +7 (812) 336 43 04 (многоканальный)

Email: org@lifeelectronics.ru