

Product manual

Piezo Keypad

CONTENTS

CONTENTS 1

1 PRODUCT DESCRIPTION 2

2 TECHNICAL DATA AND DIMENSIONAL DRAWINGS 3

 2.1 Technical Data 3

 2.2 Layout of 12 key keypad 5

 2.3 Layout of 16 key keypad 6

 2.4 Circuit diagram 7

3 ORDER NUMBERS 9

4 ACCESSORIES 9

 4.1 Accessory Kit 9

 4.2 Dimensions Accessory Kit 9

5 PACKAGING 12

6 QUALIFICATION TEST 12

 6.1 Degree of Protection 12

 6.2 EMC Protection 12

7 APPROVALS 13

8 ROHS COMPLIANT 13

Changes that contribute to technical improvement are subject to alternations.							
page	Issue date:	created by:	amendment date:	released by:	amendment no.:	datasheet no.:	index
1 of 13	27.08.2008	M. Fischer	19.08.2011	HP.Friedrich	10440	0105.9539.200	h

1 PRODUCT DESCRIPTION



- IP 69K protection class, IK 05 impact strength
 - operating temperature from -25°C to +85°C
 - long lifetime of more than 20 million actuations
 - with mounting accessories: keypad is sealed into the housing with IP 68 protection class, mounting into the housing from the front or the rear
 - as standard: keypads are available as a number block with 12 or 16 keys and with an aluminium front
 - point illumination may be integrated into the individual key fields as optical feedback or for user navigation
 - the operating panel can be designed in several colours in both the aluminium and stainless steel versions
-
- the keypads can be adapted to customer requirements with respect to the outer geometry as well as to the number and arrangement of the keys
 - particularly suitable for use in outdoor applications due to their ability to resist extreme ambient conditions such as negative temperatures, ice and snow
 - completely sealed operating panel is easy to clean and resistant to common cleaning agents

Operation principle:

The piezo keypad is based on the principle of the piezoelectric effect. By pressing, a piezoceramic generates a voltage pulse. The power of the voltage pulse is amplified from the integrated electronic circuit to a bipolar switching output.

During the voltage pulse the electronic is switching for the specified pulse duration. The switching time of the electronic switching output depends on the actuation force and the operation speed.

Connection diagram of a single switch NO (Normally Closed):

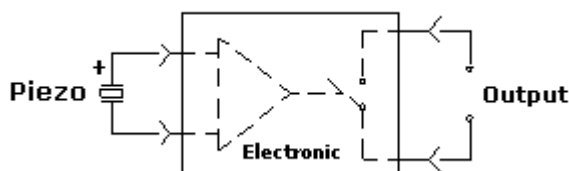

In the unactuated condition, the piezo ceramic is in a high-impedance state and the switch has an output resistance greater than 10 MOhms. If the piezo-ceramic is actuated, the output resistance is reduced to a value smaller than 20 ohms.

This corresponds largely to the functionality of a conventional mechanical switch.

Changes that contribute to technical improvement are subject to alternations.							
page	Issue date:	created by:	amendment date:	released by:	amendment no.:	datasheet no.:	index
2 of 13	27.08.2008	M. Fischer	19.08.2011	HP.Friedrich	10440	0105.9539.200	h

2 TECHNICAL DATA AND DIMENSIONAL DRAWINGS

2.1 Technical Data

<u>Electrical Data</u>		
Rated Voltage max.	[VDC]	50
Rated Current max.	[mA]	200
Contact Resistance ON	[Ω]	< 7.5<
Contact Resistance OFF	[MΩ]	> 5
Electrical Strength	[V]	2500
Contact Bounce Time	[ms]	< 1
Rated Breaking Capacity	[mW]	600

<u>Mechanical Data</u>		
Actuation Force	[N]	1 – 3 *
Lifetime	[mill.]	> 20
Shock Resistance (DIN EN 50102)	[IK]	Aluminum: 05 Stainless Steel: 04

* At ambient temperatures less than -10°C the actuating force may increase.

<u>Climatical Data</u>		
Operating Temperature	[°C]	-25 to +85
Storage Temperature	[°C]	-40 to +85
Degree of Protection *	[IP]	IP 69K

* Note: The degree of protection depends on the mounting.

Material		
Part	Material	UL-Listing
Assembling plate	Ultradur	UL94, V-0
Upper spacer		File: PGGU2.MH26206
Insulating disc	FR4	UL94, V-0
PCB	FR4	UL94, V-0
Adhesive		no listing
Casting compound		no listing
Piezo disc	PZT	
Front plate	Aluminium or Stainless Steel	

2.2 Layout of 12 key keypad

Front-design can be varied.

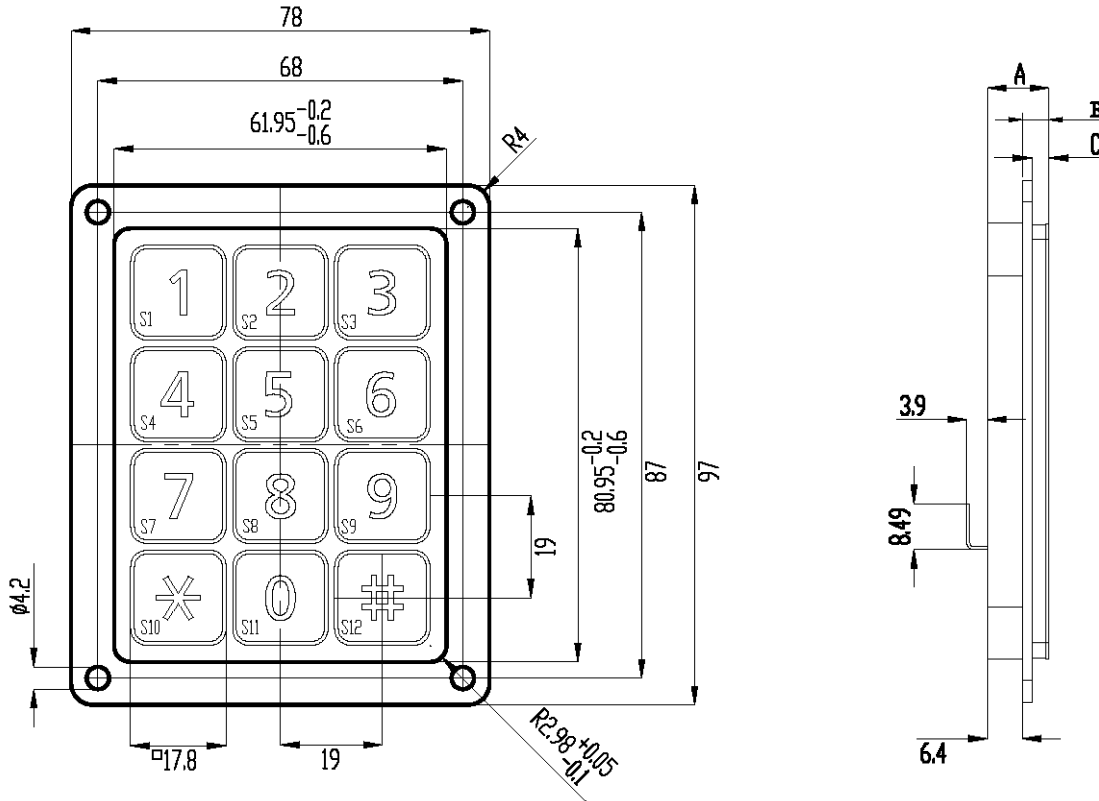

Partnumber	Material	Measures [mm]		
		A	B	C
1068.1012.1110001	Alu	11,33	4,93	3,13
1068.1012.2110001*	Stainless steel	11,23	4,83	3,03

* The version with stainless steel frontplate is available on request

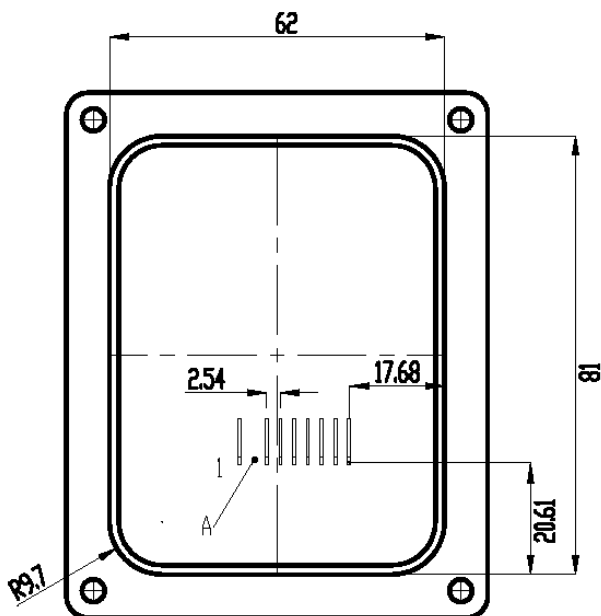

		PIN								
		1	2	3	4	5	6	7	8	9
Graphic	S1	1		■		■				
	S2	2		■			■			
	S3	3			■				■	
	S4	4			■					■
	S5	5			■					■
	S6	6	■			■				
	S7	7	■				■			
	S8	8	■					■		
	S9	9	■						■	
	S10	*	■							■
	S11	0			■	■				
	S12	#	■							■

A= Pin 2 is removed and not contacted

Changes that contribute to technical improvement are subject to alternations.							
page	Issue date:	created by:	amendment date:	released by:	amendment no.:	datasheet no.:	index
5 of 13	27.08.2008	M. Fischer	19.08.2011	HP.Friedrich	10440	0105.9539.200	h

2.3 Layout of 16 key keypad

Front-design can be varied.

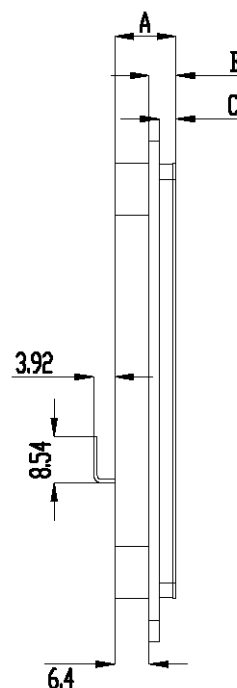
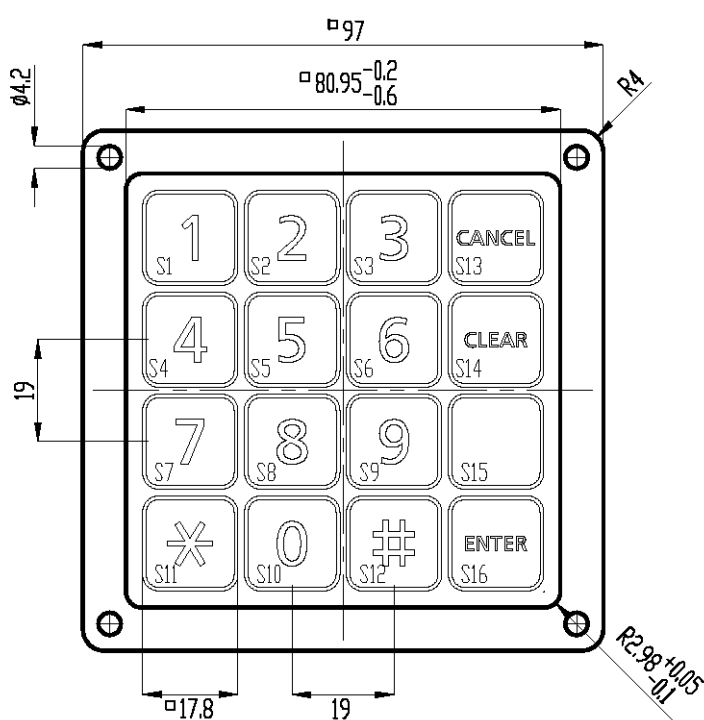

Partnumber	Material	Measures [mm]		
		A	B	C
1068.1016.1110001	Alu	11,33	4,93	3,13
1068.1016.2110001*	Stainless steel	11,23	4,83	3,03

* The version with stainless steel frontplate is available on request

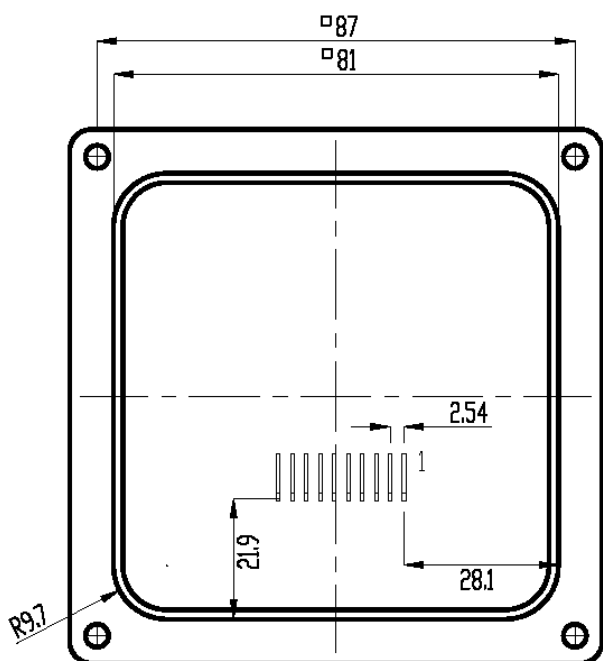

		PIN									
		1	2	3	4	5	6	7	8	9	10
Graphic	S1	1	□			□					
	S2	2	□				□				
	S3	3	□					□			
	S4	4	□						□		
	S5	5		□			□				
	S6	6		□				□			
	S7	7		□					□		
	S8	8		□						□	
	S9	9			□		□				
	S10	0			□			□			
	S11	*			□				□		
	S12	#			□					□	
	S13	Cancel				□	□				
	S14	Clear				□		□			
	S15					□			□		
	S16	Enter				□				□	

2.4 Layout of 16 Keypad with LED

Front-design can be varied.

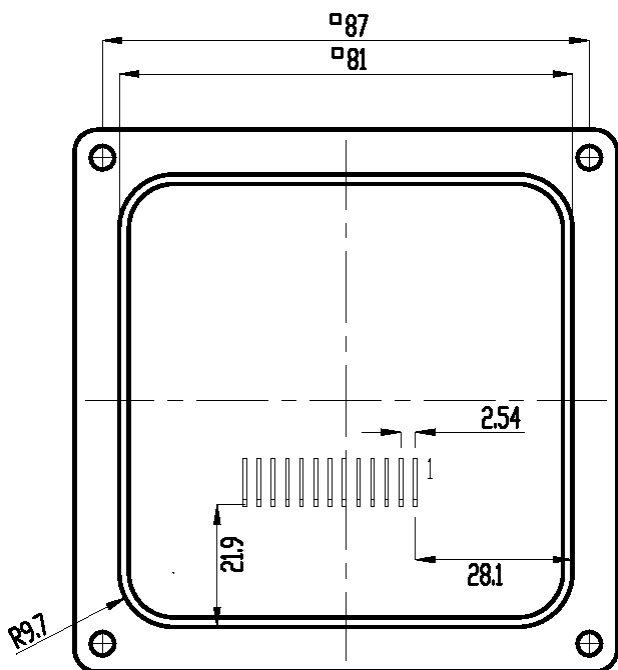
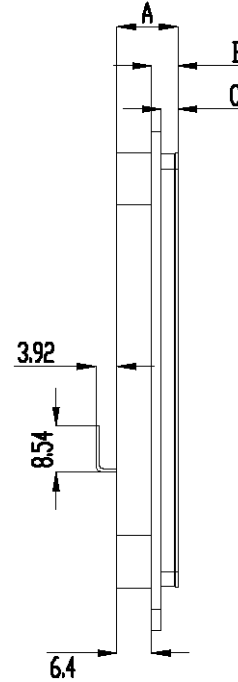
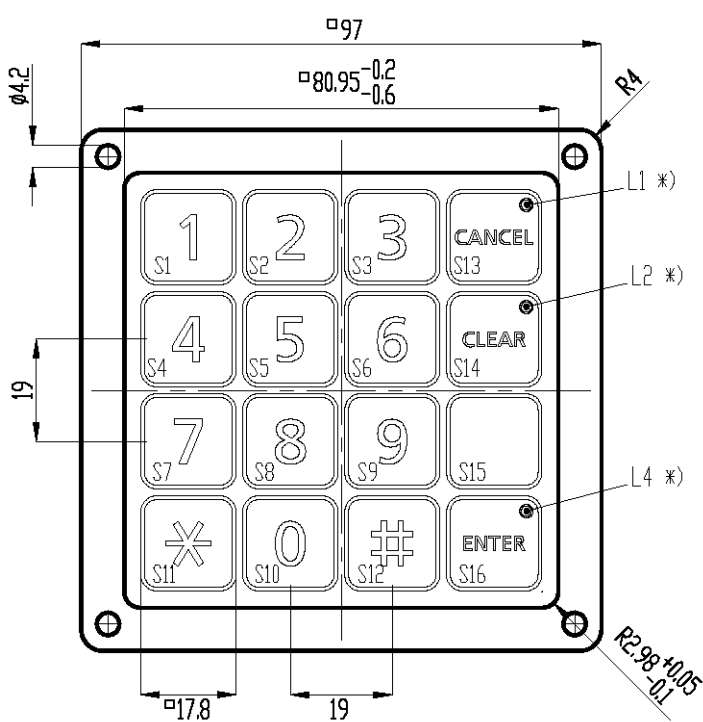

		PIN												
		1	2	3	4	5	6	7	8	9	10	11	12	13
Graphic	S1	1	■			■								
	S2	2	■				■							
	S3	3	■					■						
	S4	4	■						■					
	S5	5		■			■							
	S6	6		■				■						
	S7	7		■					■					
	S8	8		■						■				
	S9	9			■		■							
	S10	0			■			■						
	S11	*			■				■					
	S12	#			■					■				
	S13	Cancel				■	■							
	S14	Clear				■		■						
	S15					■			■					
	S16	Enter				■				■				
LEDs	L1 green									■	■			
	L2 green									■		■		
	L4 green										■		■	

*)

The point illumination is customized available on request.

2.5 Circuit diagram

12 Key Keypad

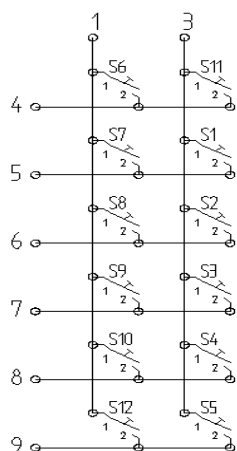

		PIN								
		1	2	3	4	5	6	7	8	9
Graphic	S1	1		■		■				
	S2	2			■		■			
	S3	3			■			■		
	S4	4			■				■	
	S5	5			■					■
	S6	6	■			■				
	S7	7	■				■			
	S8	8	■					■		
	S9	9	■						■	
	S10	*	■							■
	S11	0			■	■				
	S12	#	■							■

16 Key Keypad

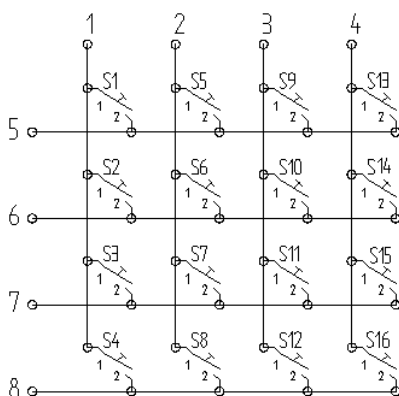

		PIN									
		1	2	3	4	5	6	7	8	9	10
Graphic	S1	1	■			■					
	S2	2	■				■				
	S3	3	■					■			
	S4	4	■						■		
	S5	5		■			■				
	S6	6		■				■			
	S7	7		■					■		
	S8	8		■						■	
	S9	9			■		■				
	S10	0			■			■			
	S11	*			■				■		
	S12	#			■					■	
	S13	Cancel				■	■				
	S14	Clear				■		■			
	S15					■			■		
	S16	Enter				■				■	

16 Key Keypad with Led

Pin 9 Led-Supply
common GND

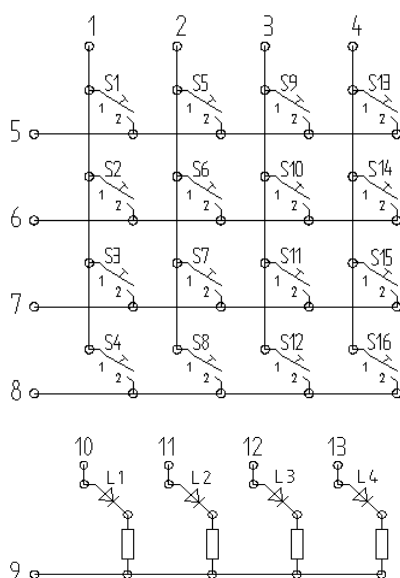

		PIN												
		1	2	3	4	5	6	7	8	9	10	11	12	13
Graphic	S1	1	■			■								
	S2	2	■				■							
	S3	3	■					■						
	S4	4	■						■					
	S5	5		■			■							
	S6	6		■				■						
	S7	7		■					■					
	S8	8		■						■				
	S9	9			■		■							
	S10	0			■			■						
	S11	*			■				■					
	S12	#			■					■				
	S13	Cancel				■	■							
	S14	Clear				■		■						
	S15					■			■					
	S16	Enter				■				■				
LEDs	L1 green									■	■			
	L2 green										■		■	
	L3 green											■		
	L4 green												■	

3 ORDER NUMBERS

	piezo keypad 12 keys	piezo keypad 16 keys
front aluminum, multi pin connector, standard lettering*	1068.1012.1110001	1068.1016.1110001

* Note: The lettering corresponds to the standard layout as described under point 2.2 and 2.3.

4 ACCESSORIES

4.1 Accessory Kit

	accessory kit for piezo keypad 12 keys	accessories kit for piezo keypad 16 keys
Mounting Frame + Sealing frontside	1068.1012.340	1068.1016.340

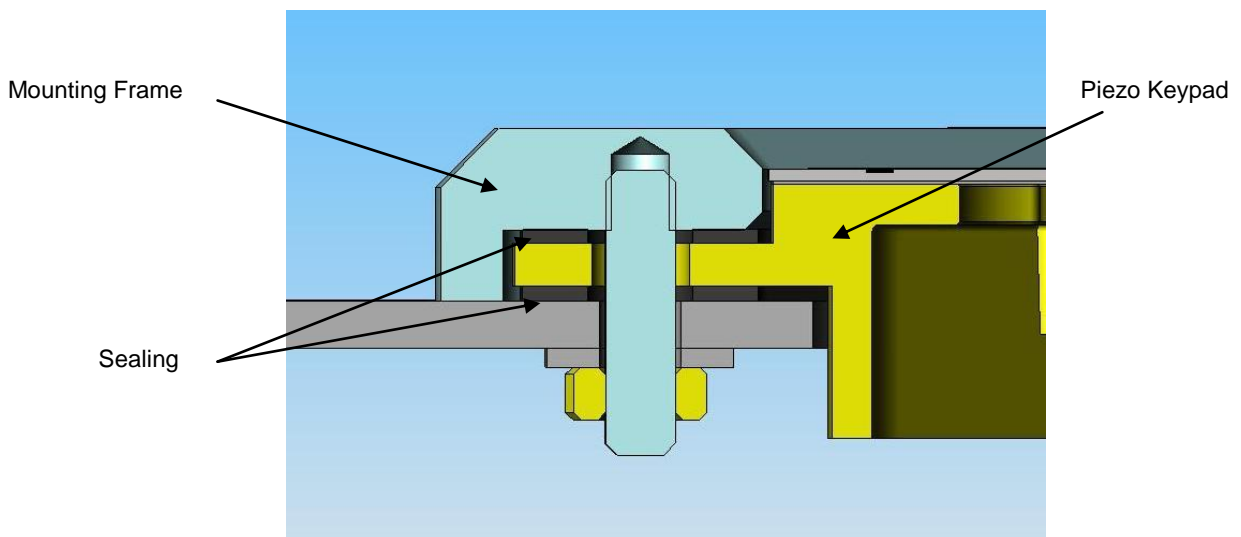

4.2 Dimensions Accessory Kit

Changes that contribute to technical improvement are subject to alternations.							
page	Issue date:	created by:	amendment date:	released by:	amendment no.:	datasheet no.:	index
9 of 13	27.08.2008	M. Fischer	19.08.2011	HP.Friedrich	10440	0105.9539.200	h

Piezo Keypad 12 keys

Mounting Frame

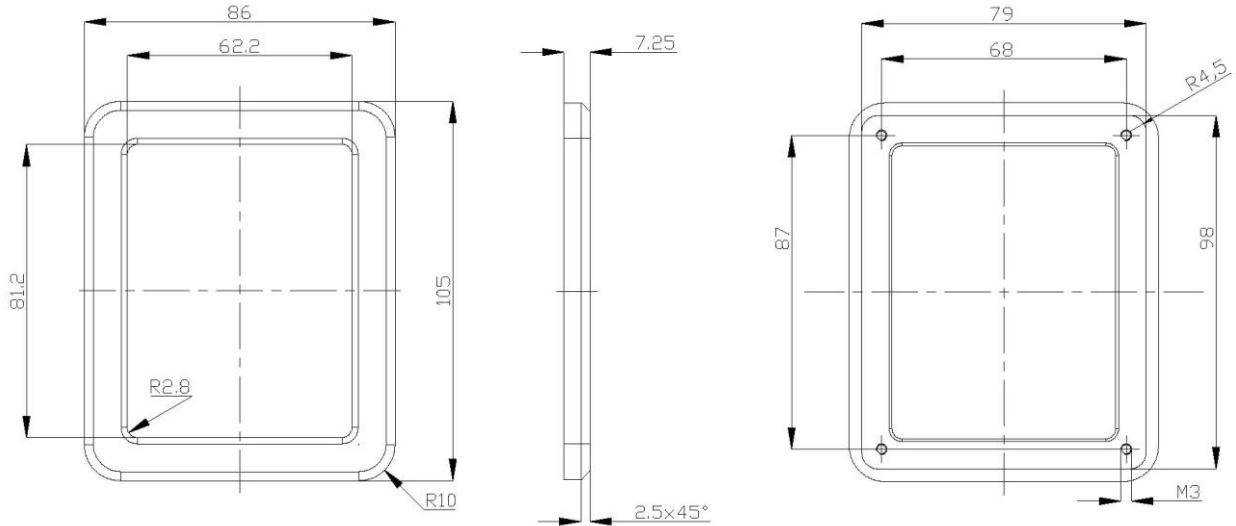

Sealing

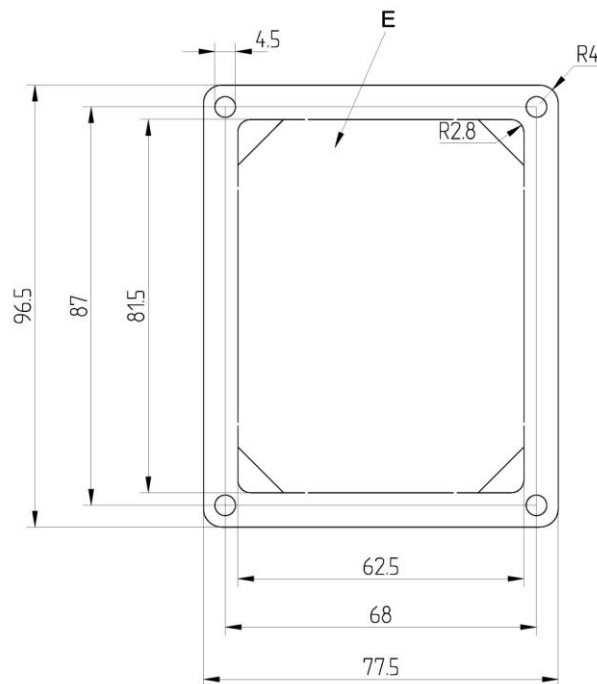

Legend

- E = Inner part falls out after mounting

Changes that contribute to technical improvement are subject to alternations.							
page	Issue date:	created by:	amendment date:	released by:	amendment no.:	datasheet no.:	index
10 of 13	27.08.2008	M. Fischer	19.08.2011	HP.Friedrich	10440	0105.9539.200	h

Piezo Keypad 16 keys

Mounting Frame

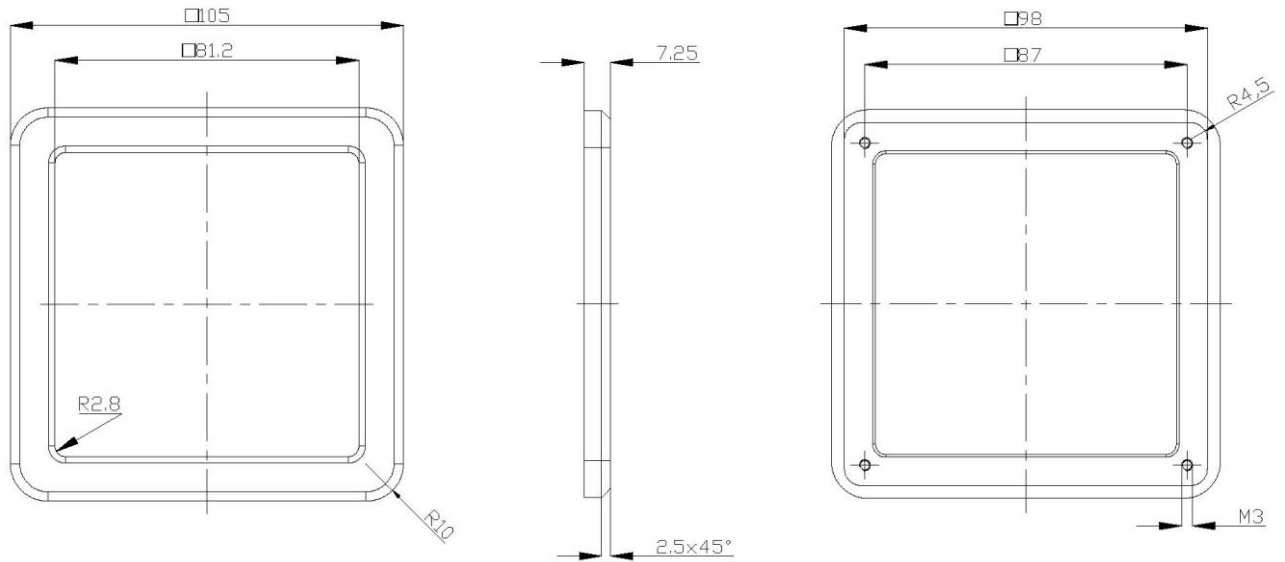

Sealing

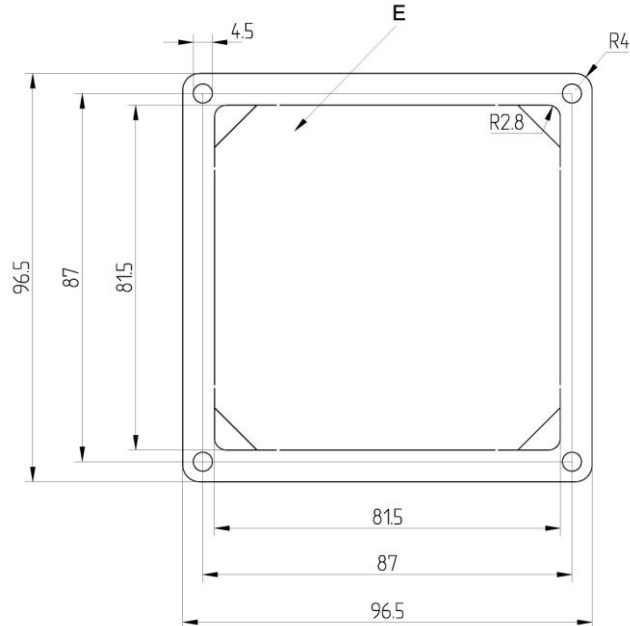

Legende

- *E = Inner part falls out after mounting*

Changes that contribute to technical improvement are subject to alternations.							
page	Issue date:	created by:	amendment date:	released by:	amendment no.:	datasheet no.:	index
11 of 13	27.08.2008	M. Fischer	19.08.2011	HP.Friedrich	10440	0105.9539.200	h

5 PACKAGING

	Packaging Unit	Type of Packaging
Piezo keypad 12 keys with protective foil	6	Reusable packaging
Piezo keypad 16 keys with protective foil	6	Reusable packaging

Note: Transport, storage and handling of piezo keypads should be in accordance with ESD guidelines.

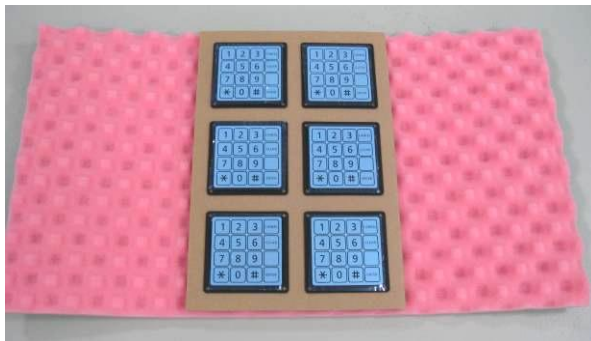

6 QUALIFICATION TEST

6.1 Degree of Protection

IP Protection IEC/DIN/EN/ 60529	Piezo Keypad: IP 69K Mounting to the housing: IP 68 *
------------------------------------	--

* The accessory kit from SCHURTER enables the keypad to be sealed into the housing with the IP 68 protection class.

6.2 EMC Protection

EMC test DIN EN 61000-4-3 (2000)	4 kV contact discharge 8 kV air discharge
-------------------------------------	--

7 APPROVALS



CE compliant

8 ROHS COMPLIANT



Changes that contribute to technical improvement are subject to alternations.							
page	Issue date:	created by:	amendment date:	released by:	amendment no.:	datasheet no.:	index
13 of 13	27.08.2008	M. Fischer	19.08.2011	HP.Friedrich	10440	0105.9539.200	h

Компания «Life Electronics» занимается поставками электронных компонентов импортного и отечественного производства от производителей и со складов крупных дистрибьюторов Европы, Америки и Азии.

С конца 2013 года компания активно расширяет линейку поставок компонентов по направлению коаксиальный кабель, кварцевые генераторы и конденсаторы (керамические, пленочные, электролитические), за счёт заключения дистрибьюторских договоров

Мы предлагаем:

- Конкурентоспособные цены и скидки постоянным клиентам.
- Специальные условия для постоянных клиентов.
- Подбор аналогов.
- Поставку компонентов в любых объемах, удовлетворяющих вашим потребностям.
- Приемлемые сроки поставки, возможна ускоренная поставка.
- Доставку товара в любую точку России и стран СНГ.
- Комплексную поставку.
- Работу по проектам и поставку образцов.
- Формирование склада под заказчика.
- Сертификаты соответствия на поставляемую продукцию (по желанию клиента).
- Тестирование поставляемой продукции.
- Поставку компонентов, требующих военную и космическую приемку.
- Входной контроль качества.
- Наличие сертификата ISO.

В составе нашей компании организован Конструкторский отдел, призванный помогать разработчикам, и инженерам.

Конструкторский отдел помогает осуществить:

- Регистрацию проекта у производителя компонентов.
- Техническую поддержку проекта.
- Защиту от снятия компонента с производства.
- Оценку стоимости проекта по компонентам.
- Изготовление тестовой платы монтаж и пусконаладочные работы.



Тел: +7 (812) 336 43 04 (многоканальный)

Email: org@lifeelectronics.ru