

REVISIONS			
LTR	DESCRIPTION	DATE	APPROVED
M	REVISED PER ECN #T-11856	8/24/77	[Signature]
N	REVISED PER ECN T-20169	6-13-95	[Signature]
P	REV PER ECO 12-020967	CT 12-12	RH

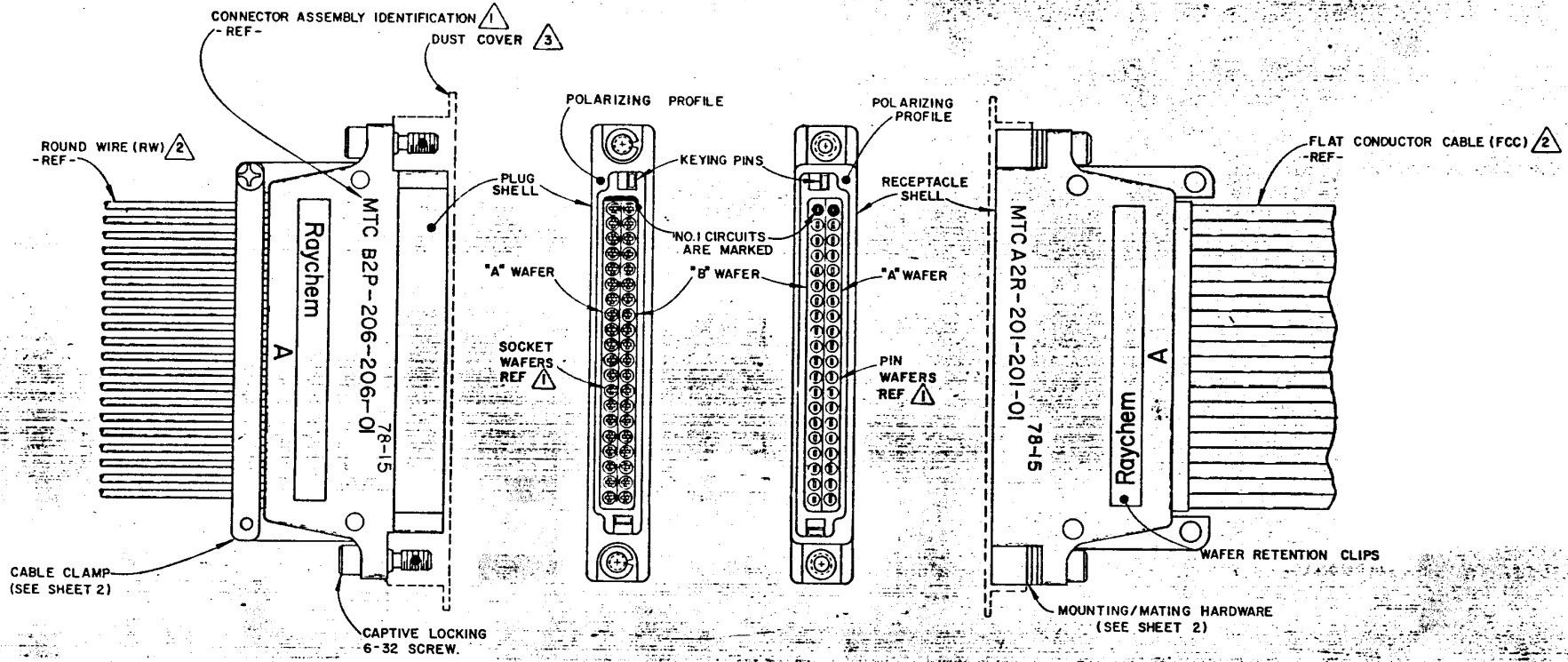

- NOTES-
- 1 PLUG & RECEPTACLE SHELLS ACCEPT BOTH PIN & SOCKET WAFERS INTERCHANGEABLY. FOR SHELL AND MOUNTING DETAILS, SEE SHEET 2. FOR WAFFER DETAILS, SEE SHEET 3.
  - 2 THE TERMINATED AND ASSEMBLED CONNECTOR IS SHOWN FOR REFERENCE. SEE SHEET 4 FOR ORDERING INFORMATION.
  - 3 DUST COVER SUPPLIED WITH EACH SHELL.

CUSTOMER DRAWING © 1976

DRAWN	V.D.T.	9-13-76	Raychem
CHECKED	[Signature]	1-25-77	SPECIFICATION CONTROL DRAWING
APPROVED			MTC CONNECTOR TYPE I, .100 INCH CENTERS ASSEMBLY
APPROVED			
APPROVED			
UNLESS OTHERWISE SPECIFIED DIMENSIONS ARE IN INCHES AND TOLERANCES ARE			SIZE CODE IDENT DWG NO
X.X ±			C NO 06090 D652-0001
X.X ±			
X.X ±			
+			DO NOT SCALE THIS DRAWING SHEET 1 OF 5

If this document is printed it becomes uncontrolled.  
Check with the web for latest revision.

REVISIONS			
LTR	DESCRIPTION	DATE	APPROVED
SEE SHEET I			

CAPTIVE CROSS RECESS  
\*4-40 FLAT HEAD SCREW  
(SELF-LOCKING)

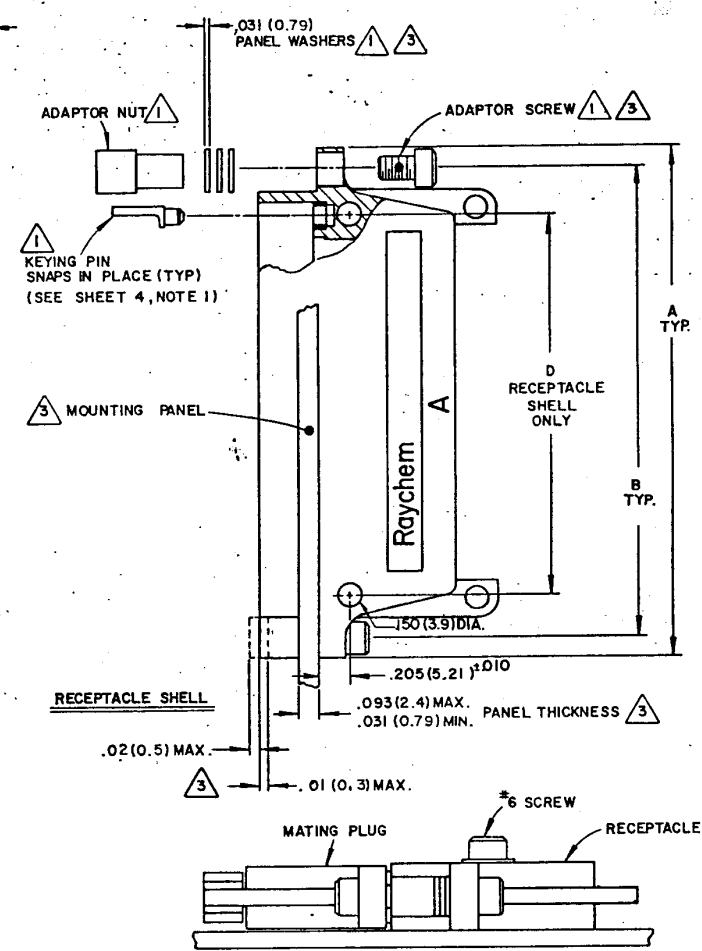
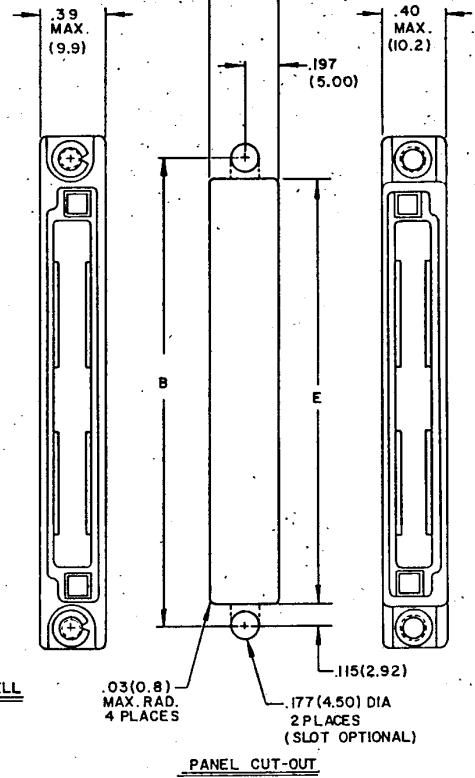
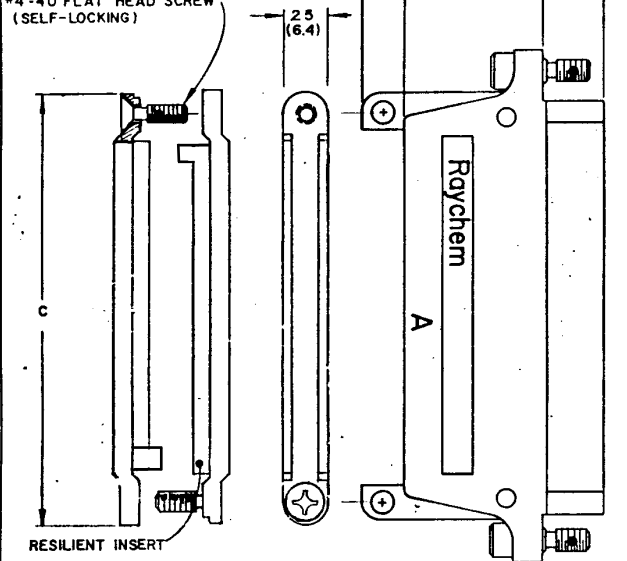

- NOTES:
- 1 KEYING PIN IS SUPPLIED UNINSTALLED. MOUNTING/MATING HARDWARE IS SUPPLIED LOOSE WITH EACH RECEPTACLE.
  - 2 CABLE CLAMP IS AVAILABLE ON BOTH PLUG & RECEPTACLE SHELLS
  - 3 RECEPTACLE IS PANEL MOUNTED BY REMOVING AS MANY PANEL WASHERS AS REQUIRED TO ACCOMMODATE THE THICKNESS OF PANEL BEING USED. DO NOT FRONT MOUNT (PANEL ON BACK SIDE OF FLANGE) WITHOUT CONSULTING FACTORY. USE ONLY ADAPTER SCREWS SUPPLIED WITH CONNECTOR. NUT TO BE FLUSH WITH RECEPTACLE WITHIN TOLERANCE INDICATED.

DIMENSION	SHELL SIZE	
	1 INCH	2 INCH
A	2.00(50.8)	3.00(76.2)
B	1.75(44.45)	2.75(69.85)
C	1.50(38.1)	2.50(63.5)
D	1.27(32.26)	2.27(57.66)
E	1.52(38.6)	2.52(64.01)
MATED LENGTH (MAX)	W/CLAMPS	W/O
	2.6 (66)	2.1 (53.3)

DRAWN	V.D.T.	9-13-76	Raychem
CHECKED	<i>[Signature]</i>	1-25-77	SPECIFICATION CONTROL DRAWING
APPROVED	<i>[Signature]</i>	2-7-77	TITLE
APPROVED			MTC CONNECTOR, SHELL 1, .100 CENTERS
APPROVED			TYP E DETAIL & MOUNTING
UNLESS OTHERWISE SPECIFIED DIMENSIONS ARE IN INCHES(MM) AND TOLERANCES ARE: .XXX : ±.005 (0.13) .XX : ±.02 (0.5)			
SIZE	CODE IDENT.	DWG. NO.	D652-0001
C	NO. 06090		
DO NOT SCALE THIS DRAWING			SHEET 2 OF 5

If this document is printed it becomes uncontrolled.  
Check with the web for latest revision.

© 1976

RAYCHEM CORPORATION  
300 CONSTITUTION DRIVE  
MENLO PARK, CA 94025

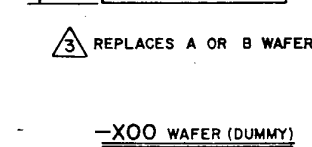
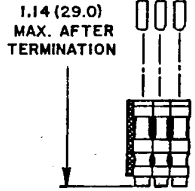
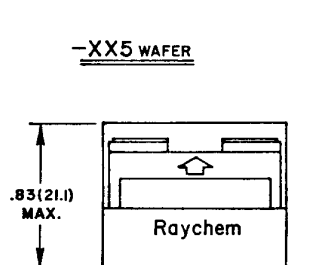
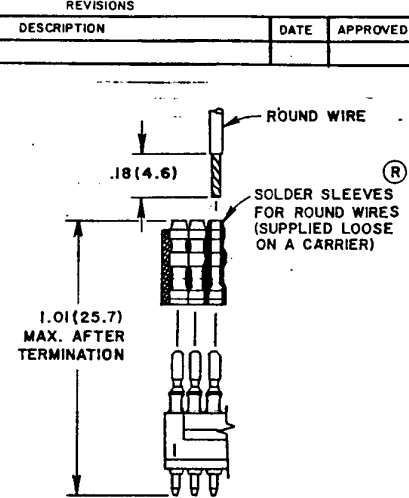
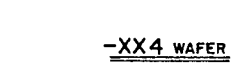
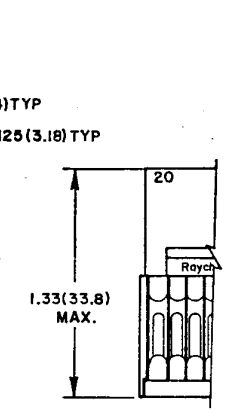
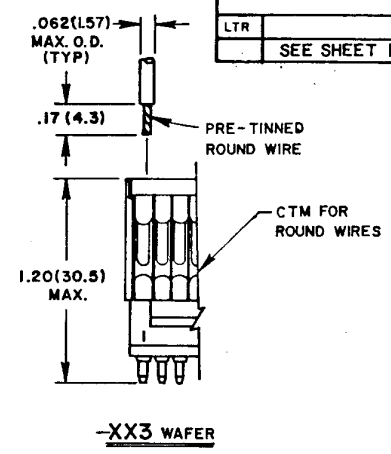
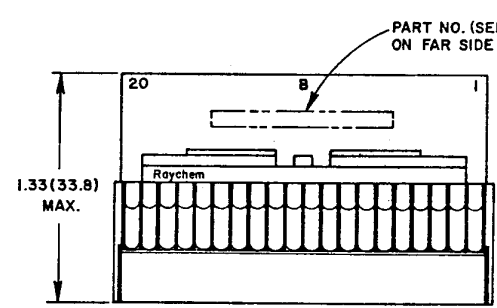
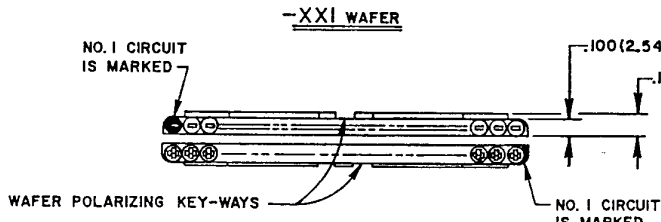
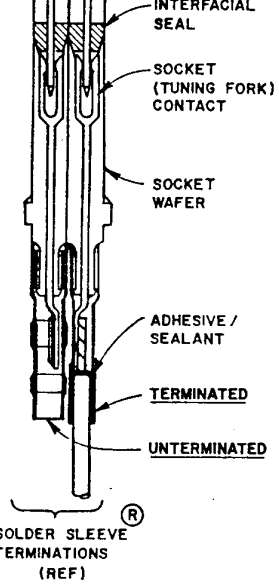
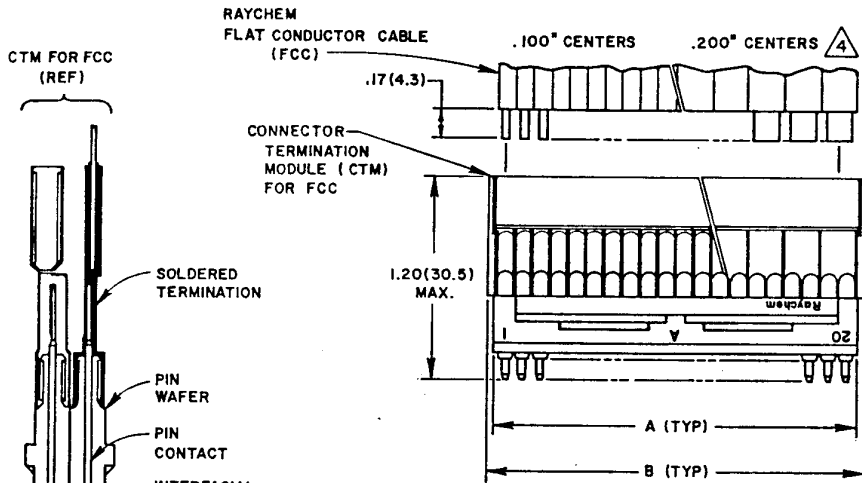

WAFER SIZE	A	B MAX.
1-INCH	1.03(26.2)	1.12(28.4)
2-INCH	2.03(51.6)	2.12(53.8)

- NOTES:
- FOR ORDERING INFORMATION SEE SHEET 4. FOR TERMINATION TOOLING REQUIREMENTS SEE SHEET 5.
  - ANY A AND B WAFER OF THE SAME WIDTH MAY BE INSTALLED IN EITHER PLUG OR RECEPTACLE SHELLS, INTERCHANGEABLY (SEE SHEET 1).
  - A DUMMY WAFER (NO CONTACTS) MAY BE SUBSTITUTED FOR ANY STYLE WAFER OF THE SAME WIDTH (SEE SHEET 4)
  - 2-INCH WAFERS ARE SHOWN FOR REFERENCE.

REVISIONS			
LTR	DESCRIPTION	DATE	APPROVED
	SEE SHEET 1		

DRAWN	CHANG	1-24-77	Raychem		
CHECKED	<i>E.M. Neil</i>	1-25-77	SPECIFICATION CONTROL DRAWING		
APPROVED	<i>W. Hall</i>	2-7-77	TITLE		
APPROVED			MTC CONNECTOR, TYPE I, .100 INCH CENTERS WAFER DETAIL		
APPROVED			SIZE	CODE IDENT.	DWG. NO.
UNLESS OTHERWISE SPECIFIED DIMENSIONS ARE IN INCHES AND TOLERANCES ARE: (MM)			C	NO. 06090	D652-0001
.XXX : ± .005 (0.13) .XX : ± .02 (0.5) - : ±			DO NOT SCALE THIS DRAWING		

If this document is printed it becomes uncontrolled.  
Check with the web for latest revision.

© 1976

RAYCHEM CORPORATION  
300 COMBUSTION DRIVE  
MENLO PARK, CA 94028

REVISIONS			
REV	DESCRIPTION	DATE	APPROVED
	SEE SHEET 1		

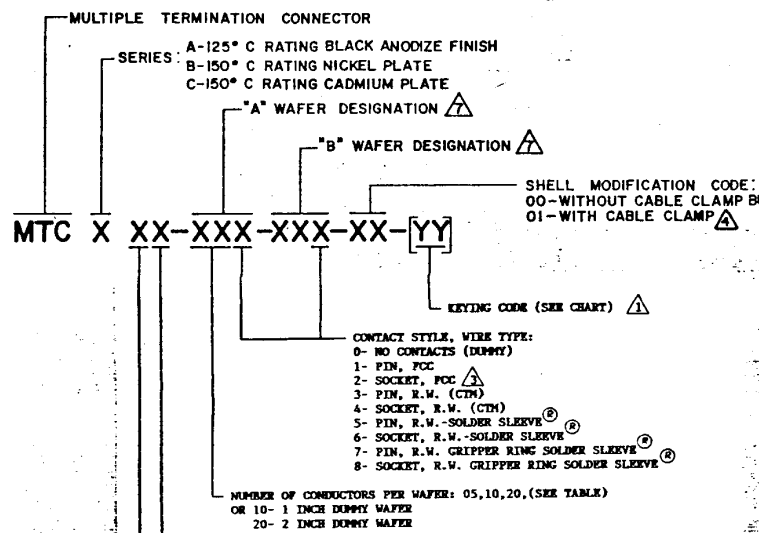

ACCESSORIES / REPLACEMENTS			
DESCRIPTION	QTY (REF)	FOR USE WITH	
		SERIES A OR B	SERIES C
CABLE CLAMP, 1-INCH	2	CB1276-000	CHA-0091
CABLE CLAMP, 2-INCH	2	CB1277-000	CHA-0092
KEYING PIN	2	D659-0043	
ADAPTOR NUT	2	D659-0043	CHA-0095
PANEL WASHER	6	D659-0042	CHA-0093
ADAPTOR SCREW	2	D659-0044	CHA-0094
MOCK-UP WAFER 1-INCH	A/R	D659-0063	
MOCK-UP WAFER 2-INCH	A/R	D659-0064	
SOLDER SLEEVE	A/R		
A SERIES, 1-INCH STRIP		D659-0028	
A SERIES, 2-INCH STRIP		D659-0038	
B OR C SERIES, 1-INCH STRIP		CTA-0026	
B OR C SERIES, 2-INCH STRIP		CTA-0027	

WIRE TYPE	CONDUCTOR CENTER SPACING	NUMBER OF CONDUCTORS PER WAFER		CONDUCTOR AWG.	MAXIMUM ROUND WIRE O.D.
RW	.100	10	20	26-20	.062 (1.57)
FCC				24-22	

CONNECTOR WIDTH (NOM)	1 INCH	2 INCH
CABLE ACCOMMODATION		

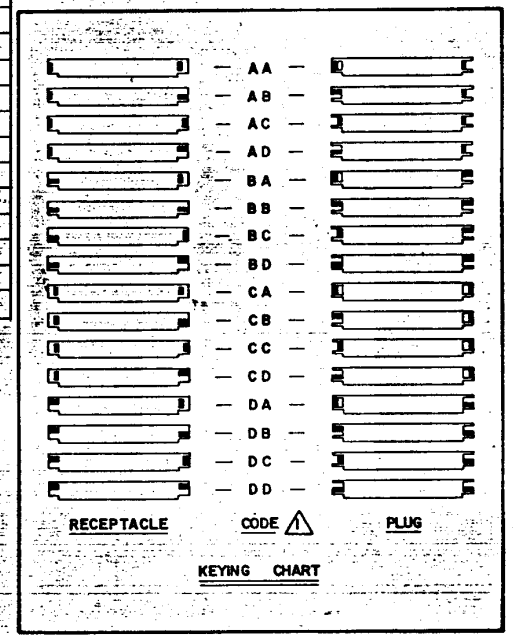

- NOTES-
- KEYING CODE DOES NOT FORM A PART OF RAYCHEM PART NUMBERING SYSTEM AND SHOULD BE OMITTED WHEN ORDERING. SHELLS ARE SUPPLIED WITH A BLANK SPACE FOR KEYING CODE, KEYING PINS ARE SUPPLIED UN-INSTALLED.
  - WHEN SUPPLIED AS PART OF A COMPLETE CONNECTOR, SHELL WILL BE MARKED WITH COMPLETE CONNECTOR PART NUMBER. WHEN SUPPLIED SEPARATELY, SHELL WILL BE PROVIDED WITH BLANKS FOR WAFER DESIGNATION.
  - CONNECTOR IS DESIGNED TO ACCEPT RAYCHEM FLAT CABLE PER RAYCHEM SPECIFICATION 50. (125°C OPERATION)
  - FOR TORQUE REQUIREMENTS ON MATING SEE RCPS 200-21.
  - FOR ORDERING REPLACEMENT OR ACCESSORY ITEMS, REFER TO THE RAYCHEM SPECIFICATION CONTROL DRAWINGS INDICATED IN THE TABLE.
  - EXAMPLES OF PART NUMBERING:  
 MTCB 2P-205-205-01 COMPLETE 150°C CONNECTOR WITH:  
 2" PLUG SHELL (NO CABLE CLAMP)  
 A PIN WAFER WITH SOLDER SLEEVE ROUND WIRE TERMINATIONS, .100 CENTERS  
 B PIN WAFER WITH FLAT CABLE MTM, .100 CENTERS.  
 MTCB 2X-XXX-206 B SOCKET WAFER WITH SOLDER SLEEVE ROUND WIRE TERMINATIONS.  
 MTCX 2X-200-200 2" DUMMY WAFER

DRAWN	V.D.T.	9-13-76	Raychem		
CHECKED	<i>[Signature]</i>	1-25-77	SPECIFICATION CONTROL DRAWING		
APPROVED	<i>[Signature]</i>	2-7-77	TITLE		
APPROVED			MTC CONNECTOR		
APPROVED			TYPE I, .100 INCH CENTERS		
			ORDERING INFORMATION		
UNLESS OTHERWISE SPECIFIED DIMENSIONS ARE IN INCHES AND TOLERANCES ARE			SIZE	CODE IDENT	DWG NO.
.XX			C	NO 06090	D652-0001
.XX			DO NOT SCALE THIS DRAWING		
			SHEET 4 OF 5		

© 1976

If this document is printed it becomes uncontrolled.  
 Check with the web for latest revision.

## SPECIFICATION

Refer to Raychem Specification D-6006  
for complete details  
Unless Otherwise Specified

### Ratings

Temperature	MTCA	-65°C to +125°C
	MTCB	-65°C to +150°C
	MTCC	-65°C to +150°C
Voltage	500 volts	
Current	5 amps	

### Materials

MTM Insulating Body	Polyvinylidene Fluoride
Solder Sleeve Tubing	Polyvinylidene Fluoride
Sealing Material	Thermally Stabilized Thermoplastic
Wafer Material	High grade Polyarylene Thermoplastic
Solder	MTCA -Sn63 per QQ-S-571 MTCB -Sb5 per QQ-S-571
Flux	Per QQ-S-571 type SRAP
Contact Finish	Gold Plated per MIL-G-45204, Type I, Grade C, Class 1 on mating surfaces
Shell Finish	MTCA -Black Anodized per MIL-A-8625, Type II MTCB -Electroless nickel per MIL-C-26074, Class 3, Grade B MTCC -Cadmium plate per QQ-P-416 over nickel underplate
Mounting/Mating Hardware	Stainless Steel, passivated for MTCA and MTCB connectors Stainless Steel, Cadmium plated for BTCC connectors
Elastomeric Seals	Fluorosilicone Rubber

### Tooling Required

Consult Factory For Tooling Required

### Summary of Specifications

Test	Test Method	Performance Requirement
Insulation Resistance	*Method 3003	
Room Temperature	23°C	5000 Megohms, minimum
Upper Rated Temperature	after 1000 hours	200 Megohms, minimum
Dielectric Withstanding Voltage		
Sea Level	*Method 3001, 1500 VAC rms, 60 Hz	No breakdown or flashover
High Altitude	*Method 105, 70,000 ft., 375 VAC rms, 60 Hz	No breakdown or flashover
Contact Resistance		
At Rated Current	Initial After Conditioning	10 milliohms maximum 12 milliohms
At Low Level Current	Initial After Conditioning	10 milliohms 14 milliohms
Shell-to-Shell Conductivity	1 amp	50 millivolts maximum
Electrical Engagement	Fully Mated Position	.050" minimum Engaging Separating
Contact Engaging and Separating Forces	Initial (max. avg.) After Conditioning	9 oz. max. 1 oz. min. 12 oz. max. 1 oz. min.
Durability	500 cycles	No damage, pass Contact Resistance

▲ ENTIRE SYSTEM MUST BE CADMIUM PLATED FOR 500 HOURS SALT SPRAY COMPATABILITY TO BE EFFECTIVE.

1. THIS SPECIFICATION SHEET TAKES PRECEDENCE OVER DOCUMENTS REFERENCED HEREIN.  
REFERENCE DOCUMENTS SHALL BE OF THE ISSUES IN EFFECT ON DATE OF INVITATION TO BID.

REVISIONS		
LTR	DESCRIPTION	DATE
SEE SHEET 1		

Tensile Strength  
Flat Cable  
Round Wires

20 lbs. per inch of cable width minimum  
20 lbs. for AWG 20  
12 lbs. for AWG 22  
8 lbs. for AWG 24  
5 lbs. for AWG 26 minimum

Insert Retention \*Method 2010, 100 psi  
Contact Retention \*Method 2007, 10 lbs. load  
Connector Mating and Unmating Per D-6006, 10 cycles

Retain normal position  
Axial displacement not to exceed 0.02 inches  
Pass Contact Resistance and Engaging/Separating Forces  
No damage

Maintenance Aging 3 mating cycles, 5 wafer removal cycles, 3 mating cycles

Vibration

\*Method 2005, (20g's peak)  
Test Condition IV

No physical damage or electrical discontinuity greater than 1 microsecond

Mechanical Shock

\*Method 2004, 6 ms, Sawtooth  
9.7 ft/sec, 100g's

No physical damage or electrical discontinuity greater than 1 microsecond

Thermal Shock  
Temperature Life

\*Method 1003, rated temperatures  
\*Method 1005, 1000 hours

No cracking, crazing or physical damage  
Pass Insulation Resistance, Elevated and Ambient Temperature and Contact Resistance

Humidity

\*Method 1002, Type II  
10 cycles, 90-98% relative humidity

Insulation Resistance of 100 Megohms, minimum

Altitude Immersion

\*Method 1004, 75,000 ft., 3 cycles

Insulation Resistance of 1000 Megohms, minimum  
Pass Dielectric Withstanding Voltage

Altitude-Low Temp.

70,000 ft., -50°C

Dielectric Withstanding Voltage of 625 volts, 60 Hz

Salt Spray (Corrosion) ▲

\*Method 1001  
(48 hours for MTCA and MTCB connectors)  
(500 hours for MTCC connectors)

Pass Insulation Resistance and Dielectric Withstanding Voltage at Sea Level  
No damage detrimental to connector operation

Ozone Resistance

0.010 to 0.015% ozone in air for 2 hours

No cracking in termination area, pass Insulation Resistance

Fungus Resistance

MIL-STD-454, Req. 4

No fungus growth

Fluid Immersion

Misc. Fluids (see D-6006)

No damage sufficient to prevent functioning

Permeability

Indicator per MIL-I-17214

2.0 maximum

Solderability

\*\*Method 208  
MTCA-Sn63 solder at 230°C  
MTCB-Sb5 solder at 316°C

95% minimum coverage

\*MIL-STD-1344

TEST METHODS FOR ELECTRICAL CONNECTORS

\*\*MIL-STD-202

TEST METHODS FOR ELECTRICAL COMPONENT PARTS

## SPECIFICATION CONTROL DRAWING

D6520001.DRW

DRAWN	LUTTICKEN	1-22-86	<h1 style="margin: 0;">Raychem</h1>		RAYCHEM CORPORATION 300 CONSTITUTION DRIVE MENLO PARK, CALIFORNIA 94025
CHECKED			<b>TITLE</b> <b>MTC CONNECTOR</b> <b>TYPE I, .100 INCH CENTERS</b> <b>SPECIFICATION SHEET</b>		
APPROVED					
APPROVED					
UNLESS OTHERWISE SPECIFIED DIMENSIONS ARE IN INCHES. METRIC DIMENSIONS ARE IN PARENTHESES					
DO NOT SCALE THIS DRAWING	C	06090	D652-0001	D652-0001	SHEET 5 OF 5

Компания «Life Electronics» занимается поставками электронных компонентов импортного и отечественного производства от производителей и со складов крупных дистрибьюторов Европы, Америки и Азии.

С конца 2013 года компания активно расширяет линейку поставок компонентов по направлению коаксиальный кабель, кварцевые генераторы и конденсаторы (керамические, пленочные, электролитические), за счёт заключения дистрибьюторских договоров

Мы предлагаем:

- Конкурентоспособные цены и скидки постоянным клиентам.
- Специальные условия для постоянных клиентов.
- Подбор аналогов.
- Поставку компонентов в любых объемах, удовлетворяющих вашим потребностям.
- Приемлемые сроки поставки, возможна ускоренная поставка.
- Доставку товара в любую точку России и стран СНГ.
- Комплексную поставку.
- Работу по проектам и поставку образцов.
- Формирование склада под заказчика.
- Сертификаты соответствия на поставляемую продукцию (по желанию клиента).
- Тестирование поставляемой продукции.
- Поставку компонентов, требующих военную и космическую приемку.
- Входной контроль качества.
- Наличие сертификата ISO.

В составе нашей компании организован Конструкторский отдел, призванный помогать разработчикам, и инженерам.

Конструкторский отдел помогает осуществить:

- Регистрацию проекта у производителя компонентов.
- Техническую поддержку проекта.
- Защиту от снятия компонента с производства.
- Оценку стоимости проекта по компонентам.
- Изготовление тестовой платы монтаж и пусконаладочные работы.



Тел: +7 (812) 336 43 04 (многоканальный)

Email: [org@lifeelectronics.ru](mailto:org@lifeelectronics.ru)