



# Low-Cost, 2.7V to 5.5V Temperature Switches in a SOT23

## General Description

The MAX6514/MAX6515 low-cost, fully integrated temperature switches assert a logic signal when their die temperature crosses a factory-programmed threshold. Operating from a 2.7V to 5.5V supply, these devices feature a fixed voltage reference, an analog temperature sensor, and a comparator. They are available with factory-trimmed temperature trip thresholds from -45°C to +15°C and +35°C to +115°C in 10°C increments, and are accurate to  $\pm 1^\circ\text{C}$  (typ). These devices require no external components and typically consume 22 $\mu\text{A}$  of supply current. Hysteresis is pin selectable at 2°C or 10°C.

The MAX6514/MAX6515 are offered with hot-temperature thresholds (+35°C to +115°C), asserting when the temperature is above the threshold or with cold-temperature thresholds (-45°C to +15°C), asserting when the temperature is below the threshold. The MAX6514/MAX6515 can be used over a -35°C to +125°C range with a supply voltage of 2.7V to 5.5V. For applications sensing temperature down to -45°C, a supply voltage above 4.5V is required.

The MAX6514 has an active-high, push-pull output. The MAX6515 has an active-low, open-drain output. These devices are available in a space-saving 5-pin SOT23 package and operate over the -55°C to +125°C temperature range.

## Applications

- Over/Undertemperature Protection
- Fan Control
- Test Equipment
- Temperature Control
- Temperature Alarms
- Notebook, Desktop PCs
- RAID
- Servers

**Pin Configurations and Functional Diagram appear at end of data sheet.**

## Features

- ◆ High-Accuracy  $\pm 1.5^\circ\text{C}$  (max) over -15°C to +65°C Temperature Range
- ◆ Low-Power Consumption: 22 $\mu\text{A}$  Typical Current
- ◆ Factory-Programmed Thresholds from -45°C to +115°C in 10°C Increments
- ◆ Open-Drain or Push-Pull Outputs
- ◆ Pin-Selectable 2°C or 10°C Hysteresis

## Ordering Information

PART	TEMP RANGE	PIN-PACKAGE
MAX6514UK____+T	-55°C to +125°C	5 SOT23
MAX6515UK____+T	-55°C to +125°C	5 SOT23

**Note:** These parts are offered in 16 standard temperature versions with a minimum order of 2500 pieces. To complete the suffix information, add P or N for positive or negative trip temperature, and select an available trip point in degrees centigrade. For example, the MAX6514UKP065+T describes a MAX6514 in a 5-pin SOT23 package with a +65°C threshold in tape and reel (2.5k minimum order). Contact the factory for pricing and availability.

+Denotes a lead(Pb)-free/RoHS-compliant package.  
T = Tape and reel.

## Typical Operating Circuit

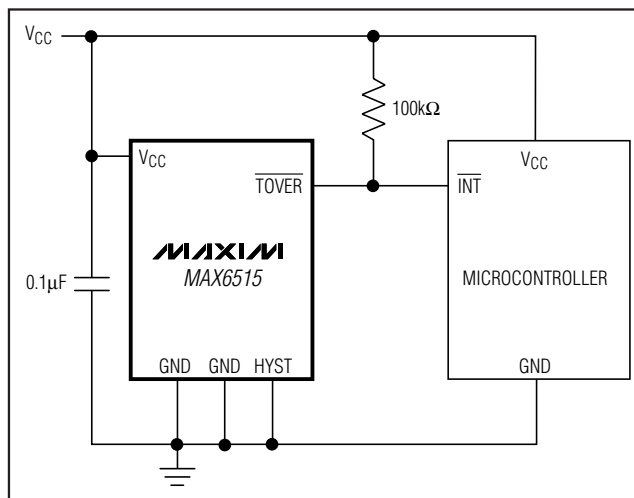

MAX6514/MAX6515

# Low-Cost, 2.7V to 5.5V Temperature Switches in a SOT23

## ABSOLUTE MAXIMUM RATINGS

All Voltages Are Referenced to GND

V <sub>CC</sub> .....	-0.3V to +6V
TOVER, TUNDER (open drain) .....	-0.3V to +6V
TOVER, TUNDER (push-pull) .....	-0.3V to V <sub>CC</sub> + 0.3V
HYST .....	-0.3V to V <sub>CC</sub> + 0.3V
Continuous Power Dissipation SOT23 (derate 3.1mW/°C above +70°C) .....	247mW

Operating Temperature Range .....	-55°C to +125°C
Junction Temperature .....	+150°C
Storage Temperature Range .....	-65°C to +150°C
Lead Temperature (soldering, 10s) .....	+300°C
Soldering Temperature .....	+260°C

Stresses beyond those listed under "Absolute Maximum Ratings" may cause permanent damage to the device. These are stress ratings only, and functional operation of the device at these or any other conditions beyond those indicated in the operational sections of the specifications is not implied. Exposure to absolute maximum rating conditions for extended periods may affect device reliability.

## ELECTRICAL CHARACTERISTICS

(V<sub>CC</sub> = 2.7V to 5.5V, R<sub>PULLUP</sub> = 100kΩ, (open-drain output only), T<sub>A</sub> = -55°C to +125°C, unless otherwise noted. Typical values are at T<sub>A</sub> = +25°C.) (Note 1)

PARAMETER	SYMBOL	CONDITIONS	MIN	TYP	MAX	UNITS
Supply Voltage Range	V <sub>CC</sub>		2.7		5.5	V
Supply Current	I <sub>CC</sub>	Hot-temperature thresholds (+35°C to +115°C)		22	40	μA
		Cold-temperature thresholds (-45°C to +15°C)		40		
Temperature Threshold Accuracy (Note 2)	ΔT <sub>TH</sub>	-15°C to +65°C	-1.5		+1.5	°C
		+75°C to +115°C	-2.5		+2.5	
		-45°C to -25°C (Note 3)	-3		+3	
Temperature Threshold Hysteresis	T <sub>HYST</sub>	HYST = V <sub>CC</sub>		2		°C
		HYST = GND		10		
HYST Input Threshold (Note 4)	V <sub>IH</sub>		0.8 x V <sub>CC</sub>			V
	V <sub>IL</sub>		0.2 x V <sub>CC</sub>			
Logic Output Voltage High (Push-Pull)	V <sub>OH</sub>	I <sub>SOURCE</sub> = 500μA, V <sub>CC</sub> > 2.7V	0.8 x V <sub>CC</sub>			V
		I <sub>SOURCE</sub> = 800μA, V <sub>CC</sub> > 4.5V	V <sub>CC</sub> - 1.5			
Logic Output Voltage Low (Push-Pull and Open Drain)	V <sub>OL</sub>	I <sub>SINK</sub> = 1.2mA, V <sub>CC</sub> > 2.7V			0.3	V
		I <sub>SINK</sub> = 3.2mA, V <sub>CC</sub> > 4.5V			0.4	
Open-Drain Output Leakage Current		V <sub>CC</sub> = 2.7V, open-drain output = 5.5V		10		nA

**Note 1:** 100% production tested at T<sub>A</sub> = +25°C. Specifications over temperature are guaranteed by design.

**Note 2:** The MAX6514/MAX6515 are available with internal factory-programmed temperature trip thresholds from -45°C to +15°C and +35°C to +115°C in 10°C increments.

**Note 3:** V<sub>CC</sub> must be greater than 4.5V for a switching threshold of -45°C.

**Note 4:** Guaranteed by design.

# Low-Cost, 2.7V to 5.5V Temperature Switches in a SOT23

## Typical Operating Characteristics

( $V_{CC} = 4.5V$ ,  $T_A = +25^\circ C$ , unless otherwise noted.)

MAX6514/MAX6515

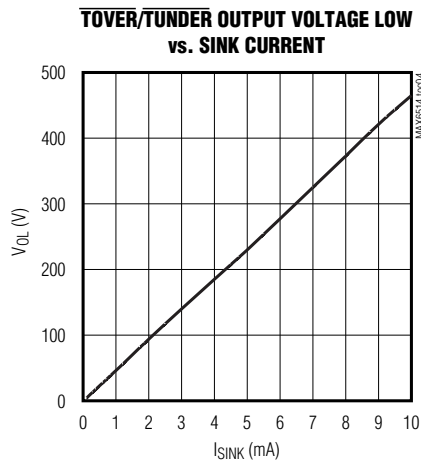
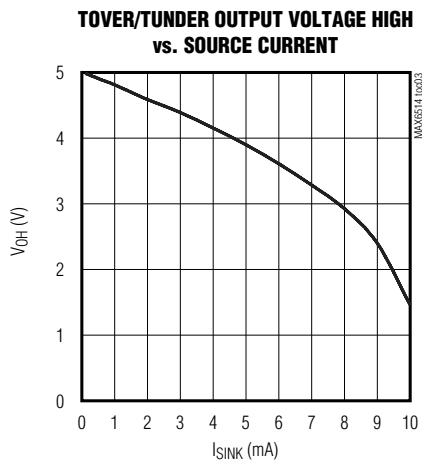
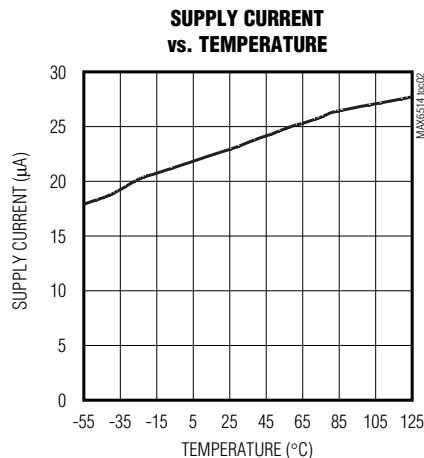
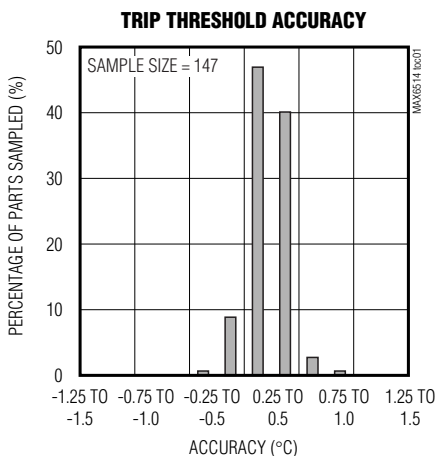

**STARTUP AND POWER-DOWN ( $TEMP < T_{TH}$ )**

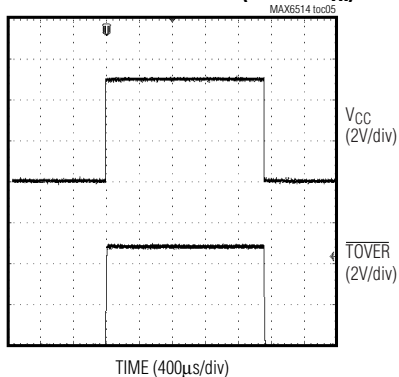

**STARTUP DELAY ( $TEMP > T_{TH}$ )**

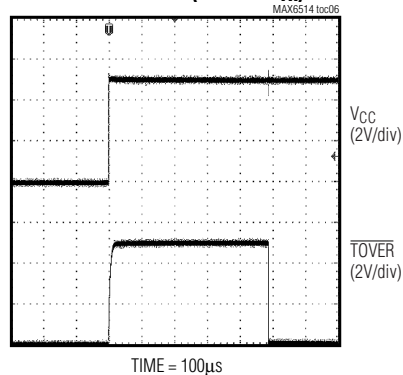

# Low-Cost, 2.7V to 5.5V Temperature Switches in a SOT23

## Pin Description

PIN		NAME	FUNCTION
MAX6514	MAX6515		
1, 2	1, 2	GND	Ground
3	3	HYST	Hysteresis Input. Connect to V <sub>CC</sub> for 2°C of hysteresis or to GND for 10°C hysteresis.
4	4	V <sub>CC</sub>	Input Supply. Bypass to ground with a 0.1µF capacitor.
5	—	TOVER	Push-Pull Active-High Output (Hot Threshold). TOVER goes high when the die temperature exceeds the factory-programmed hot-temperature threshold.
—	5	$\overline{\text{TOVER}}$	Open-Drain, Active-Low Output (Hot Threshold). $\overline{\text{TOVER}}$ goes low when the die temperature exceeds the factory-programmed hot-temperature threshold. Connect to a 100kΩ pullup resistor. Can be pulled up to a voltage higher than V <sub>CC</sub> .
5	—	TUNDER	Push-Pull Active-High Output (Cold Threshold). TUNDER goes high when the die temperature falls below the factory-programmed cold-temperature threshold.
—	5	$\overline{\text{TUNDER}}$	Open-Drain, Active-Low Output (Cold Threshold). $\overline{\text{TUNDER}}$ goes low when the die temperature goes below the factory-programmed cold-temperature threshold. Connect to a 100kΩ pullup resistor. Can be pulled up to a voltage higher than V <sub>CC</sub> .

## Detailed Description

The MAX6514/MAX6515 fully integrated temperature switches incorporate a fixed reference, an analog temperature sensor, and a comparator. Pin-selectable 2°C or 10°C hysteresis keeps the digital output from oscillating when the die temperature approaches the threshold temperature. The MAX6514 has an active-high, push-pull output structure that can sink or source current. The MAX6515 has an active-low, open-drain output structure that can only sink current. The internal power-on reset circuit guarantees the logic output is at its +25°C state for at least 50µs.

### Hysteresis Input

The HYST input selects the devices' temperature hysteresis and prevents the output from oscillating when the temperature approaches the trip point. Connect HYST to V<sub>CC</sub> for 2°C hysteresis or to GND for 10°C hysteresis.

## Logic Temperature Indicators

### Overtemperature Indicator (Hot Thresholds)

TOVER and  $\overline{\text{TOVER}}$  designations apply to thresholds above T<sub>A</sub> = +25°C (+35°C, +45°C, +55°C, +65°C, +75°C, +85°C, +95°C, +105°C, and +115°C). All "hot" thresholds are positive temperatures.

The overtemperature indicator output is open drain active low ( $\overline{\text{TOVER}}$ ) or push-pull active high (TOVER).  $\overline{\text{TOVER}}$  goes low when the die temperature exceeds the factory-programmed temperature threshold.  $\overline{\text{TOVER}}$  should be pulled up to a voltage no greater than 5.5V with a 100kΩ pullup resistor. TOVER is a push-pull active-high CMOS output that goes high when the die temperature exceeds the factory-programmed temperature threshold.

### Undertemperature Indicator (Cold Thresholds)

TUNDER and  $\overline{\text{TUNDER}}$  designations apply to thresholds below T<sub>A</sub> = +25°C (+15°C, +5°C, -5°C, -15°C, -25°C, -35°C, -45°C). The undertemperature indicator output is open-drain, active low ( $\overline{\text{TUNDER}}$ ) or push-pull, active high (TUNDER).  $\overline{\text{TUNDER}}$  goes low when the die temperature goes below the factory-programmed temperature threshold.  $\overline{\text{TUNDER}}$  should be pulled up to a voltage no greater than 5.5V with a 100kΩ pullup resistor. TUNDER is a push-pull active-high CMOS output that goes high when the die temperature falls below the factory-programmed temperature threshold.

# Low-Cost, 2.7V to 5.5V Temperature Switches in a SOT23

MAX6514/MAX6515

## Applications Information

### Temperature-Window Alarm

The MAX6515 logic output asserts when the die temperature is outside the factory-programmed range. Combining the outputs of two devices creates an over/undertemperature alarm. Two MAX6515s are used to form two complementary pairs, containing one cold trip-point output and one hot trip-point output. The assertion of either output alerts the system to an out-of-range temperature (Figure 1).

The thermal overrange signal can be used to assert a thermal shutdown, power-up, recalibration, or other temperature-dependent function.

### Low-Cost, Fail-Safe Temperature

In high-performance/high-reliability applications, multiple temperature monitoring is important. The high-level integration and low cost of the MAX6514/MAX6515 facilitate the use of multiple temperature monitors to increase system reliability. The Figure 2 application uses two MAX6514s with different hot-temperature thresholds to ensure that fault conditions that can overheat the monitored device cause no permanent damage. The first temperature monitor activates the fan when the die temperature exceeds +45°C. The second MAX6514 triggers a system shutdown if the die temperature reaches +75°C, preventing damage from a wide variety of destructive fault conditions, including latchups, short circuits, and cooling-system failures.

### Thermal Considerations

The MAX6514/MAX6515 supply current is typically 22µA. When used to drive high-impedance loads, the devices dissipate negligible power and self-heating effects are minimized.

Accurate temperature monitoring depends on the thermal resistance between the device being monitored and the MAX6514/MAX6515 die. Heat flows in and out of plastic packages, primarily through the leads. Pin 2 of the 5-pin SOT23 package provides the lowest thermal resistance to the die. Short, wide copper traces between the MAX6514/MAX6515 and the objects whose temperature is being monitored ensure heat transfers occur quickly and reliably. The rise in die temperature due to self-heating is given by the following formula:

$$\Delta T_J = P_{DISSIPATION} \times \theta_{JA}$$

where  $P_{DISSIPATION}$  is the power dissipated by the MAX6514/MAX6515, and  $\theta_{JA}$  is the thermal resistance of the package.

The typical thermal resistance is +140°C/W for the 5-pin SOT23 package. To limit the effects of self-heating, minimize the output current. For example, if the MAX6514/MAX6515 sink 1mA, the open-drain output voltage is guaranteed to be less than 0.3V. Therefore, an additional 0.3mW of power is dissipated within the IC. This corresponds to a 0.042°C shift in the die temperature in the 5-pin SOT23 package.

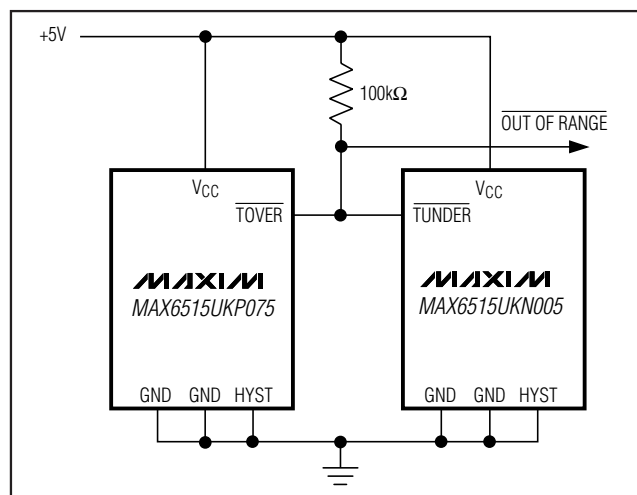

Figure 1. Temperature-Window Alarms Using the MAX6515

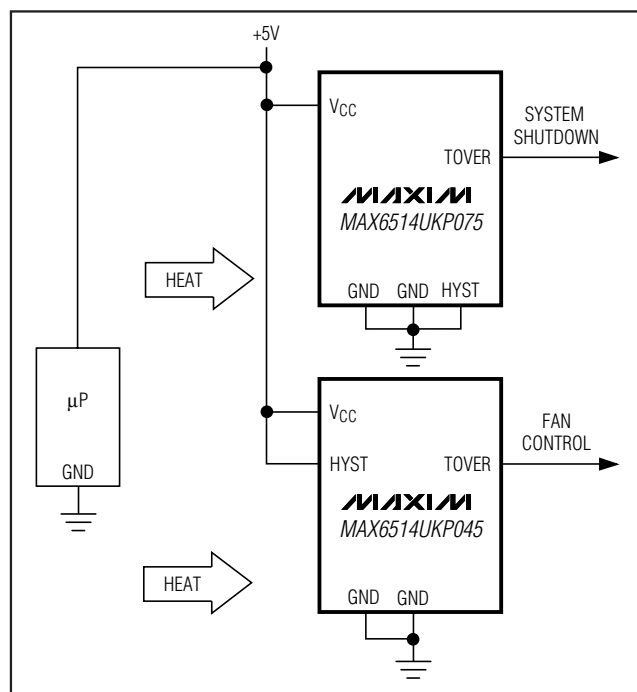

Figure 2. Low-Power, High-Reliability, Fail-Safe Temperature Monitor

# Low-Cost, 2.7V to 5.5V Temperature Switches in a SOT23

Table 1. Top Marks

PART	TOP MARK
MAX6514UKN005	AEKU
MAX6514UKN015	AEKV
MAX6514UKN025	AEKW
MAX6514UKN035	AECV
MAX6514UKN045	AEKX
MAX6514UKP005	AEKY
MAX6514UKP015	AEKZ
MAX6514UKP035	AELA
MAX6514UKP045	AELB
MAX6514UKP055	AELC
MAX6514UKP065	AELD
MAX6514UKP075	AECW
MAX6514UKP085	AELE
MAX6514UKP095	AELF
MAX6514UKP105	AELG
MAX6514UKP115	AELH

PART	TOP MARK
MAX6515UKN005	AEMK
MAX6515UKN015	AEML
MAX6515UKN025	AEMM
MAX6515UKN035	AECX
MAX6515UKN045	AEMN
MAX6515UKP005	AEMO
MAX6515UKP015	AEMP
MAX6515UKP035	AEMQ
MAX6515UKP045	AEMR
MAX6515UKP055	AEMS
MAX6515UKP065	AEMT
MAX6515UKP075	AECY
MAX6515UKP085	AEMU
MAX6515UKP095	AEMV
MAX6515UKP105	AEMW
MAX6515UKP115	AEMX

## Pin Configurations

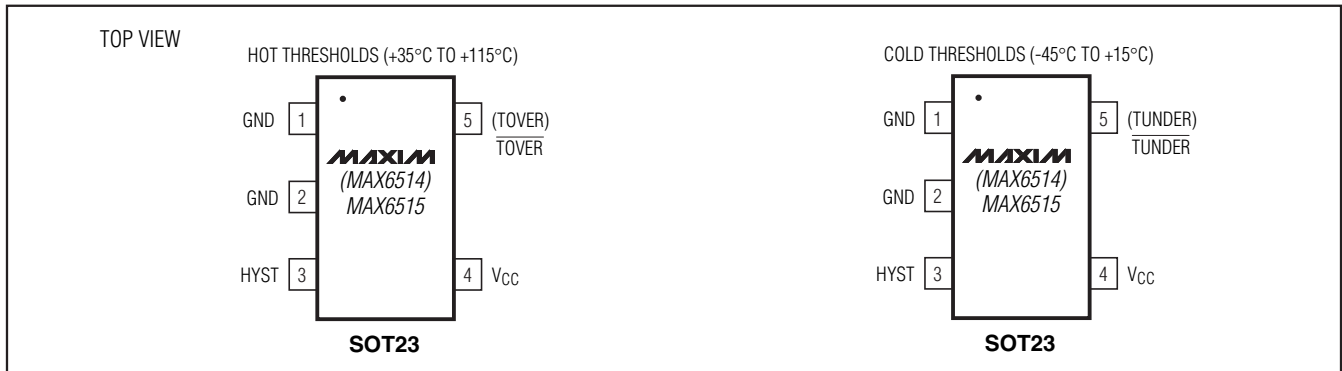

## Chip Information

PROCESS: BiCMOS

## Package Information

For the latest package outline information and land patterns (footprints), go to [www.maxim-ic.com/packages](http://www.maxim-ic.com/packages). Note that a “+”, “#”, or “-” in the package code indicates RoHS status only. Package drawings may show a different suffix character, but the drawing pertains to the package regardless of RoHS status.

PACKAGE TYPE	PACKAGE CODE	OUTLINE NO.	LAND PATTERN NO.
5 SOT23	U5+2	<a href="#">21-0057</a>	<a href="#">90-0174</a>

# Low-Cost, 2.7V to 5.5V Temperature Switches in a SOT23

## MAX6514/MAX6515 Functional Diagram

**MAX6514/MAX6515**

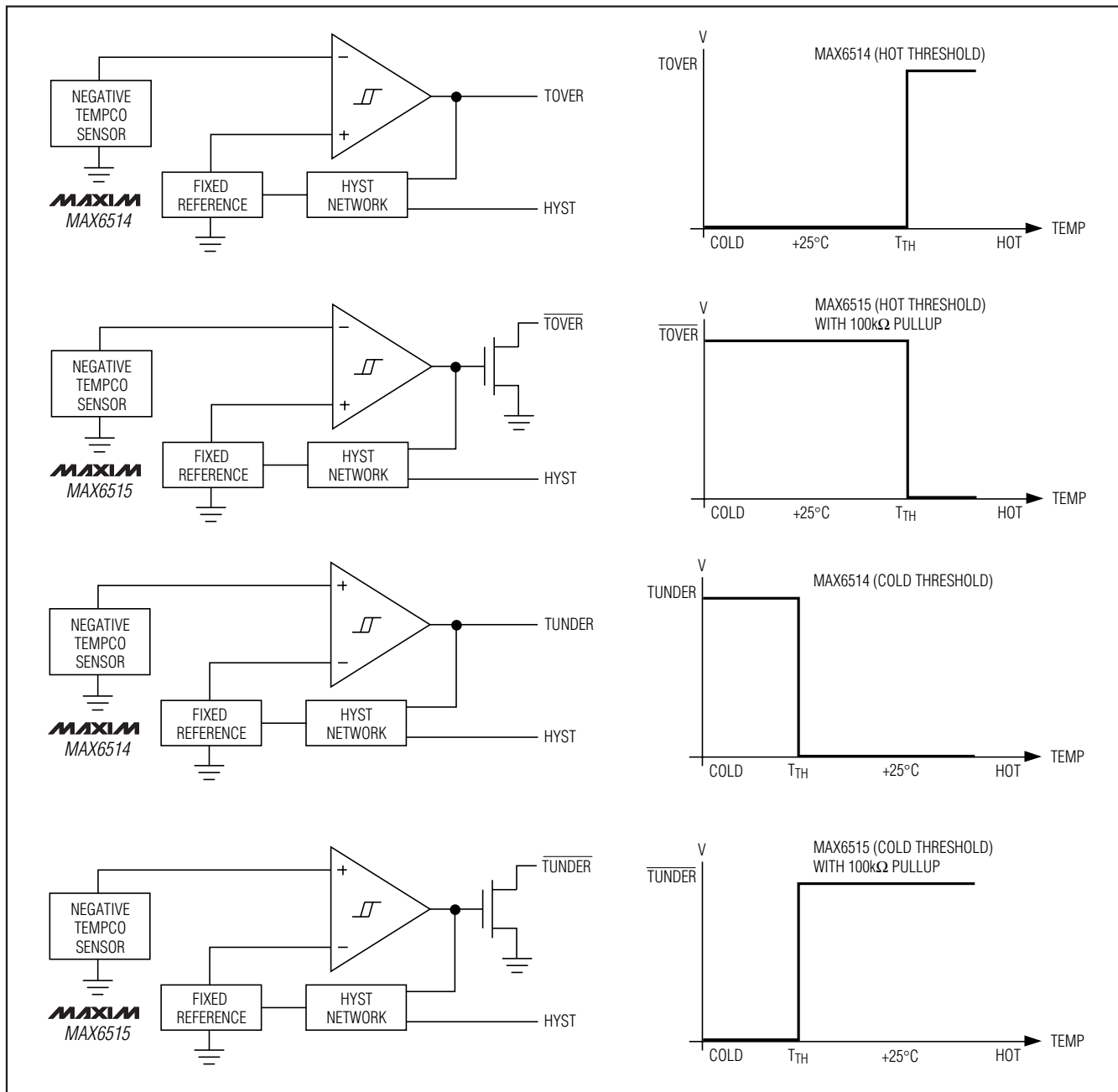

# Low-Cost, 2.7V to 5.5V Temperature Switches in a SOT23

## Revision History

REVISION NUMBER	REVISION DATE	DESCRIPTION	PAGES CHANGED
0	1/04	Initial release	—
1	2/11	Changed the leaded parts to lead(Pb)-free parts in the <i>Ordering Information</i> table; in the <i>Absolute Maximum Ratings</i> section changed the continuous power dissipation numbers (7.1mW/°C to 3.1mW/°C and 571mW to 247mW); added the <i>Package Information</i> table	1, 2, 6

Maxim cannot assume responsibility for use of any circuitry other than circuitry entirely embodied in a Maxim product. No circuit patent licenses are implied. Maxim reserves the right to change the circuitry and specifications without notice at any time.

8 **Maxim Integrated Products, 120 San Gabriel Drive, Sunnyvale, CA 94086 408-737-7600**



Компания «Life Electronics» занимается поставками электронных компонентов импортного и отечественного производства от производителей и со складов крупных дистрибьюторов Европы, Америки и Азии.

С конца 2013 года компания активно расширяет линейку поставок компонентов по направлению коаксиальный кабель, кварцевые генераторы и конденсаторы (керамические, пленочные, электролитические), за счёт заключения дистрибьюторских договоров

Мы предлагаем:

- Конкурентоспособные цены и скидки постоянным клиентам.
- Специальные условия для постоянных клиентов.
- Подбор аналогов.
- Поставку компонентов в любых объемах, удовлетворяющих вашим потребностям.
- Приемлемые сроки поставки, возможна ускоренная поставка.
- Доставку товара в любую точку России и стран СНГ.
- Комплексную поставку.
- Работу по проектам и поставку образцов.
- Формирование склада под заказчика.
- Сертификаты соответствия на поставляемую продукцию (по желанию клиента).
- Тестирование поставляемой продукции.
- Поставку компонентов, требующих военную и космическую приемку.
- Входной контроль качества.
- Наличие сертификата ISO.

В составе нашей компании организован Конструкторский отдел, призванный помогать разработчикам, и инженерам.

Конструкторский отдел помогает осуществить:

- Регистрацию проекта у производителя компонентов.
- Техническую поддержку проекта.
- Защиту от снятия компонента с производства.
- Оценку стоимости проекта по компонентам.
- Изготовление тестовой платы монтаж и пусконаладочные работы.



Тел: +7 (812) 336 43 04 (многоканальный)

Email: [org@lifeelectronics.ru](mailto:org@lifeelectronics.ru)