

MAXIM

Dual, High-Efficiency, PFM, Step-Up DC-DC Controller

MAX863

General Description

The MAX863 dual-output DC-DC converter contains two independent step-up controllers in a single compact package. This monolithic Bi-CMOS design draws only 85 μ A when both controllers are on. The input range extends down to 1.5V, permitting use in organizers, translators, and other low-power hand-held products. The MAX863 provides 90% efficiency at output loads from 20mA to over 1A. This space-saving device is supplied in a 16-pin QSOP package that fits in the same area as an 8-pin SOIC.

The device uses a current-limited, pulse-frequency-modulated (PFM) control architecture that reduces start-up surge currents and maintains low quiescent currents for excellent low-current efficiency. Each controller drives a low-cost, external, N-channel MOSFET switch, whose size can be optimized for any output current or voltage.

In larger systems, two MAX863s can be used to generate 5V, 3.3V, 12V, and 28V from just two or three battery cells. An evaluation kit (MAX863EVKIT) is available to speed designs. For a single-output controller, refer to the MAX608 and MAX1771 data sheets.

Applications

2- and 3-Cell Portable Equipment
Organizers
Translators
Hand-Held Instruments
Palmtop Computers
Personal Digital Assistants (PDAs)
Dual Supply (Logic and LCD)

Pin Configuration

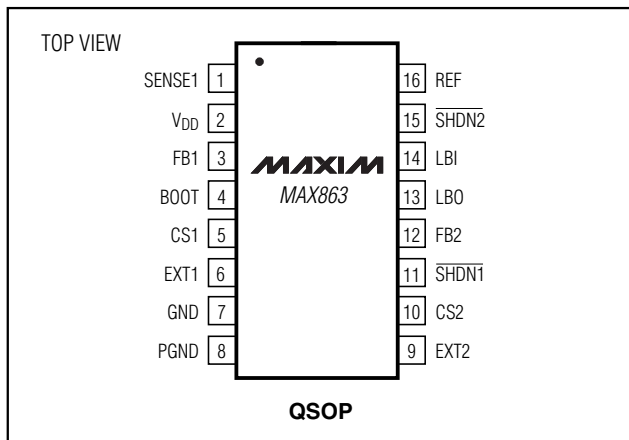

Features

- ◆ Smallest Dual Step-Up Converter: 16-Pin QSOP
- ◆ 90% Efficiency
- ◆ 1.5V Start-Up Voltage
- ◆ 85 μ A Max Total Quiescent Supply Current
- ◆ 1 μ A Shutdown Mode
- ◆ Independent Shutdown Inputs
- ◆ Drives Surface-Mount, Dual N-Channel MOSFETs
- ◆ Low-Battery Input/Output Comparator
- ◆ Step-Up/Down Configurable

Ordering Information

PART	TEMP. RANGE	PIN-PACKAGE
MAX863C/D	0°C to +70°C	Dice*
MAX863EEE	-40°C to +85°C	16 QSOP

*Dice are tested at $T_A = +25^\circ\text{C}$.

Typical Operating Circuit

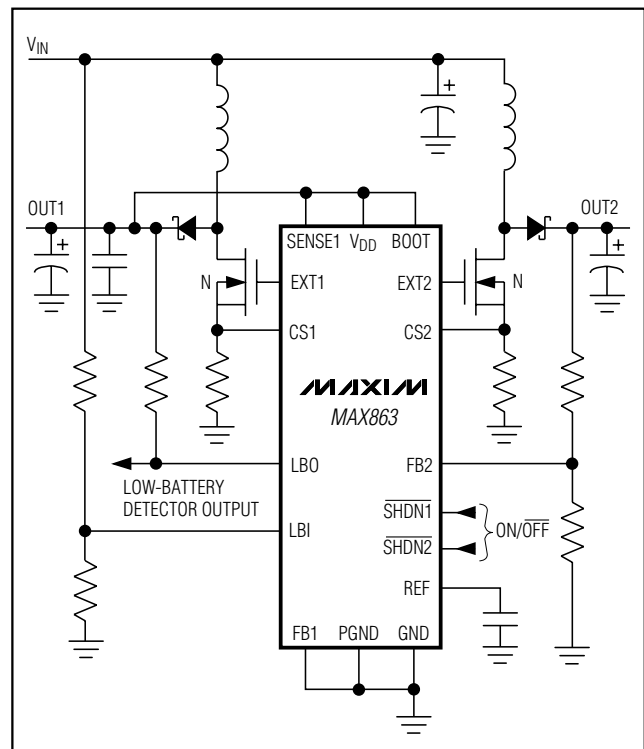
**MAXIM**

Maxim Integrated Products 1

For pricing, delivery, and ordering information, please contact Maxim/Dallas Direct! at 1-888-629-4642, or visit Maxim's website at www.maxim-ic.com.

Dual, High-Efficiency, PFM, Step-Up DC-DC Controller

ABSOLUTE MAXIMUM RATINGS

V _{DD} to GND	-0.3V to +12V	Continuous Power Dissipation (T _A = +70°C)	
PGND to GND	-0.3V to +0.3V	QSOP (derate 8.30mW/°C above +70°C)	667mW
SHDN1, SHDN2, SENSE1, LBO to GND	-0.3V to +12V	Operating Temperature Range	
EXT1, EXT2 to PGND.....	-0.3V to (V _{DD} + 0.3V)	MAX863EEE	-40°C to +85°C
FB1, FB2, CS1, CS2, SEL, LBI, BOOT to GND.....	-0.3V to (V _{DD} + 0.3V)	Junction Temperature	+150°C
LBO Continuous Output Current.....	15mA	Storage Temperature Range	-65°C to +160°C
EXT1, EXT2 Continuous Output Current.....	50mA	Lead Temperature (soldering, 10sec).....	+300°C

Stresses beyond those listed under "Absolute Maximum Ratings" may cause permanent damage to the device. These are stress ratings only, and functional operation of the device at these or any other conditions beyond those indicated in the operational sections of the specifications is not implied. Exposure to absolute maximum rating conditions for extended periods may affect device reliability.

ELECTRICAL CHARACTERISTICS

(V_{DD} = +5V, I_{LOAD} = 0mA, T_A = 0°C to +85°C, unless otherwise noted. Typical values are at T_A = +25°C.)

PARAMETER	SYMBOL	CONDITIONS	MIN	TYP	MAX	UNITS
V _{DD} Input Voltage	V _{DD}	V _{DD} = OUT1 = BOOT (Note 1)	1.5		11	V
		(Note 2)	2.7		11	
OUT1 Output Voltage (Note 3)	V _{OUT1}	FB1 = V _{DD}	3.2	3.3	3.4	V
		FB1 = GND	4.85	5	5.15	
Quiescent Current	I _{DD}	SHDN1 = SHDN2 = V _{DD} , measured from V _{DD}		50	85	μA
		SHDN1 = V _{DD} , SHDN2 = GND, measured from V _{DD}		35	60	
Shutdown Current	I _{DD} , SHDN	SHDN1 = SHDN2 = GND			1	μA
Load Regulation		V _{IN} = 3.3V, V _{OUT1} = 5V, I _{LOAD} = 0mA to 500mA, Figure 2		40		mV/A
Line Regulation		V _{IN} = 2.7V to 5V, V _{OUT1} = 5V, I _{LOAD} = 300mA, Figure 2		8		mV/V
FB1, FB2, LBI Threshold Voltage (Note 4)	V _{FB} , V _{LBI}		1.225	1.25	1.275	V
FB1, FB2, LBI Input Current	I _{FB} , I _{LBI}			2	10	nA
SHDN1, SHDN2, SEL, BOOT Input High Voltage	V _{IH}	2.7V < V _{DD} < 11V		1.6		V
		V _{DD} = 1.5V		0.7 x V _{DD}		
SHDN1, SHDN2, SEL, BOOT Input Low Voltage	V _{IL}	2.7V < V _{DD} < 11V			0.4	V
		V _{DD} = 1.5V			0.2 x V _{DD}	
SHDN1, SHDN2, SEL, BOOT Input Current	I _I	Logic input = V _{DD} or GND			1	μA
CS1, CS2 Threshold Voltage	V _{CS}		85	100	115	mV
CS1, CS2 Input Current				1	25	μA
Maximum Switch On-Time	t _{ON}		14	17.5	22	μs
Minimum Switch Off-Time	t _{OFF}		1.6	2	2.4	μs
EXT Rise/Fall Time (Note 5)		C _{LOAD} = 1nF, 10% to 90%		50		ns
EXT On-Resistance				5		Ω
LBO Leakage Current	I _{LBO}	V _{LBO} = 11V, V _{LBI} > 1.275V			1	μA
LBO Low Level	V _{LBO,L}	I _{LBO,SINK} = 1mA, V _{LBI} < 1.225V		0.1	0.4	V

Dual, High-Efficiency, PFM, Step-Up DC-DC Controller

MAX863

ELECTRICAL CHARACTERISTICS

($V_{DD} = +5V$, $I_{LOAD} = 0mA$, $T_A = -40^{\circ}C$ to $+85^{\circ}C$, unless otherwise noted.) (Note 6)

PARAMETER	SYMBOL	CONDITIONS	MIN	TYP	MAX	UNITS
V_{DD} Input Voltage	V_{DD}	$V_{DD} = OUT1$ (Note 1)	1.6		11	V
		(Note 2)	2.8		11	
OUT1 Output Voltage (Note 3)	V_{OUT1}	$FB1 = V_{DD}$	3.15		3.45	V
		$FB1 = GND$	4.8		5.2	
Quiescent Current	I_{DD}	$\overline{SHDN1} = \overline{SHDN2} = V_{DD}$, measured from V_{DD}			85	μA
		$\overline{SHDN1} = V_{DD}$, $\overline{SHDN2} = GND$, measured from V_{DD}			60	
Shutdown Current	I_{DD}, \overline{SHDN}	$\overline{SHDN1} = \overline{SHDN2} = GND$			1	μA
FB1, FB2 Threshold Voltage	V_{FB}		1.21		1.285	V
CS1, CS2 Threshold Voltage	V_{CS}		85		115	mV

Note 1: When bootstrapped, an internal low-voltage oscillator drives the EXT1 pin rail-to-rail for low supply voltages.

Note 2: For non-bootstrapped operation, $V_{DD} > 2.7V$ is required to allow valid operation of all internal circuitry.

Note 3: For adjustable output voltages, see the *Set the Output Voltage* section.

Note 4: Measured with LBI falling. Typical hysteresis is 15mV.

Note 5: EXT1 and EXT2 swing from V_{DD} to GND.

Note 6: Specifications to $-40^{\circ}C$ are guaranteed by design and not production tested.

Typical Operating Characteristics

($T_A = +25^{\circ}C$, unless otherwise noted.)

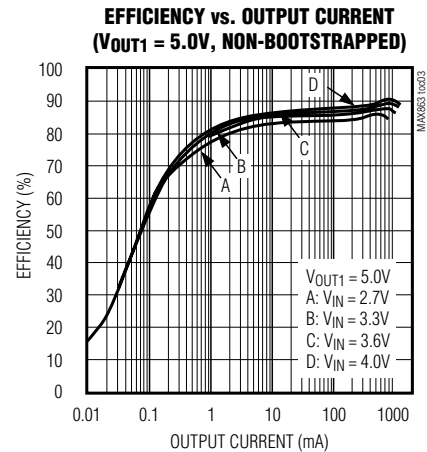
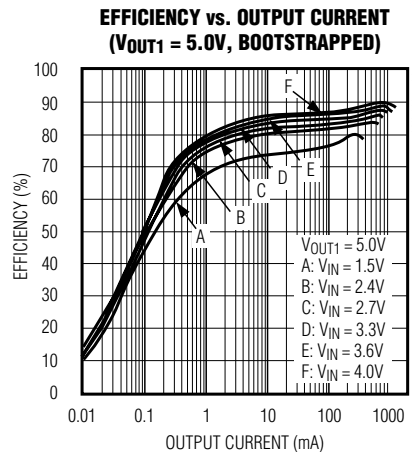
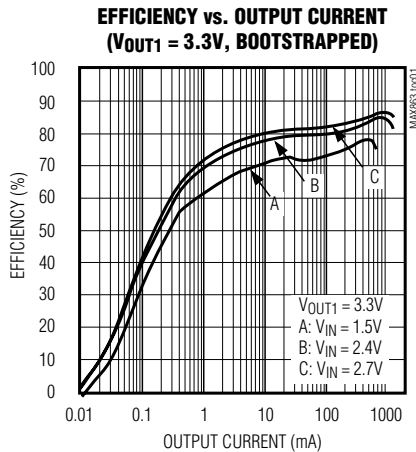

Dual, High-Efficiency, PFM, Step-Up DC-DC Controller

Typical Operating Characteristics (continued)

($T_A = +25^\circ\text{C}$, unless otherwise noted.)

**EFFICIENCY vs. OUTPUT CURRENT
($V_{OUT1} = 12\text{V}$, NON-BOOTSTRAPPED)**

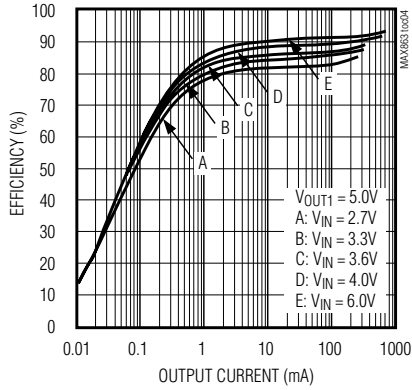

**BOOTSTRAPPED-MODE MINIMUM
START-UP INPUT VOLTAGE
vs. OUTPUT CURRENT**

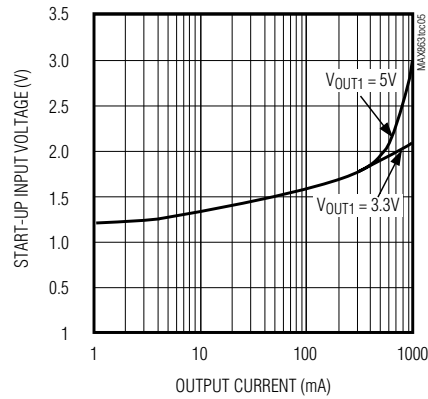

**V_{DD} CURRENT
vs. V_{DD} VOLTAGE**

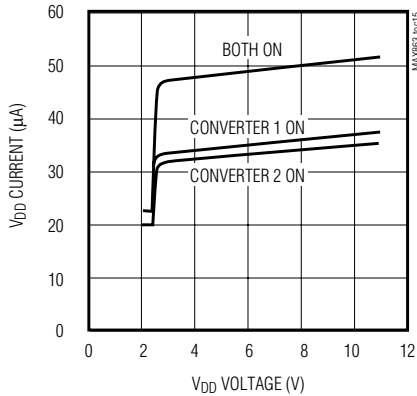

**EXT RISE AND FALL TIMES vs.
SUPPLY VOLTAGE AND MOSFET CAPACITANCE**

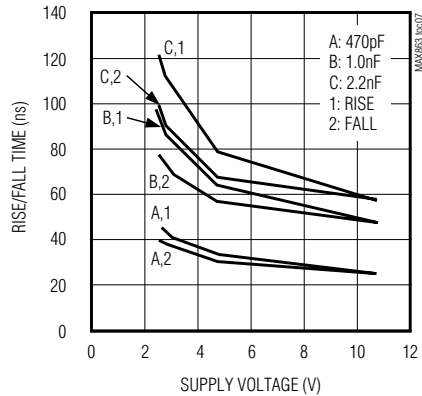

LOAD-TRANSIENT RESPONSE

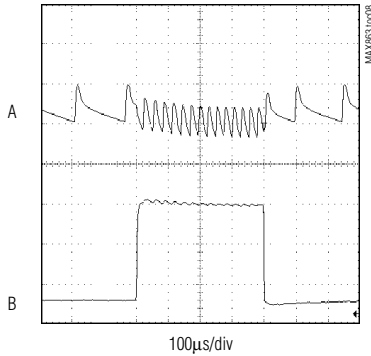

$V_{OUT1} = 3.3\text{V}$, $I_{OUT1} = 100\text{mA TO } 600\text{mA}$
 A: V_{OUT1} , 100mV/div, 3.3V DC OFFSET
 B: I_{OUT1} , 200mA/div

**RESPONSE ENTERING/
EXITING SHUTDOWN (BOOTSTRAPPED)**

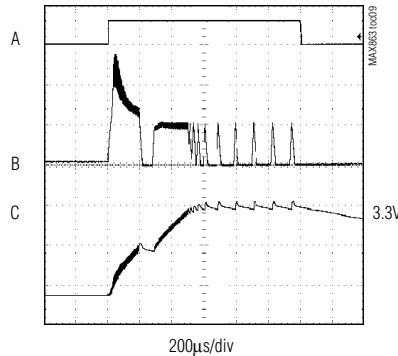

$V_{OUT1} = 3.3\text{V}$, $I_{OUT1} = 100\text{mA}$, $V_{IN} = 2.4\text{V}$
 A: SHDN1, 5V/div
 B: INDUCTOR CURRENT, 2A/div
 C: V_{OUT1} , 3.3V OFFSET, 500mV/div

LINE-TRANSIENT RESPONSE

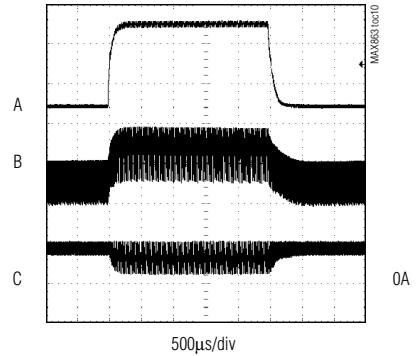

$V_{OUT1} = 5\text{V}$, $I_{OUT1} = 800\text{mA}$
 A: $V_{IN} = 2.7\text{V TO } 3.7\text{V}$, 500mV/div
 B: V_{OUT1} , AC COUPLED, 50mV/div
 C: INDUCTOR CURRENT, 2A/div

Dual, High-Efficiency, PFM, Step-Up DC-DC Controller

MAX863

Pin Description

PIN	NAME	FUNCTION
1	SENSE1	Feedback Input for DC-DC Controller 1 in Fixed-Output Mode
2	V _{DD}	IC Power-Supply Input
3	FB1	Adjustable Feedback and Preset Output Voltage Selection Input for DC-DC Controller 1. Connect to V _{DD} for 3.3V preset output or to GND for 5V output. Connect a resistor voltage divider to adjust the output voltage. See the section <i>Set the Output Voltage</i> .
4	BOOT	Bootstrap Low-Voltage-Oscillator Enable Input. BOOT is an active-high, logic-level input. It enables the low-voltage oscillator to allow start-up from input voltages down to 1.5V while in a bootstrapped circuit configuration. Connect BOOT to GND when in a non-bootstrapped configuration. If BOOT is high, V_{DD} must be connected to OUT1.
5	CS1	Input to the Current-Sense Comparator of DC-DC Controller 1
6	EXT1	Gate-Drive Output of DC-DC Controller 1. Drives an external N-channel power MOSFET.
7	GND	Analog Ground for Internal Reference, Feedback, and Control Circuits
8	PGND	High-Current Ground Return for Internal MOSFET Drivers
9	EXT2	Gate-Drive Output of DC-DC Controller 2. Drives an external N-channel power MOSFET.
10	CS2	Input to the Current-Sense Amplifier of DC-DC Controller 2
11	$\overline{\text{SHDN1}}$	Active-Low Shutdown Input for DC-DC Controller 1. Connect to V _{DD} for normal operation.
12	FB2	Adjustable Feedback Input for DC-DC Controller 2. Connect a resistor voltage divider to adjust the output voltage. See the section <i>Set the Output Voltage</i> .
13	LBO	Low-Battery Output. An open-drain N-channel MOSFET output. Sinks current when the voltage on LBI drops below 1.25V. If unused, connect to GND.
14	LBI	Low-Battery Comparator Input. When the voltage on LBI drops below 1.25V, LBO sinks current. If unused, connect to GND.
15	$\overline{\text{SHDN2}}$	Active-Low Shutdown Input for DC-DC Controller 2. Connect to V _{DD} for normal operation.
16	REF	Reference Bypass Input. Connect a 0.1 μ F ceramic capacitor from REF to GND.

Detailed Description

The MAX863 dual, bi-CMOS, step-up, switch-mode power-supply controller provides preset 3.3V, 5V, or adjustable outputs. Its pulse-frequency-modulated (PFM) control scheme combines the advantages of low supply current at light loads and high efficiency with heavy loads. These attributes make the MAX863 ideal for use in portable battery-powered systems where small size and low cost are extremely important, and where low quiescent current and high efficiency are needed to maximize operational battery life. Use of external current-sense resistors and MOSFETs allows the designer to tailor the output current and voltage capability for a diverse range of applications.

PFM Control Scheme

Each DC-DC controller in the MAX863 uses a one-shot-sequenced, current-limited PFM design, as shown in Figure 1. Referring to the Typical Operating Circuit (Figure 2) and the switching waveforms (Figures 3a–3f), the circuit works as follows. Output voltage is sensed by the error comparator using either an internal voltage divider connected to SENSE1 or an external voltage divider connected to FB1. When the output voltage drops, the error comparator sets an internal flip-flop. The flip-flop turns on an external MOSFET, which allows inductor current to ramp-up, storing energy in a magnetic field.

Dual, High-Efficiency, PFM, Step-Up DC-DC Controller

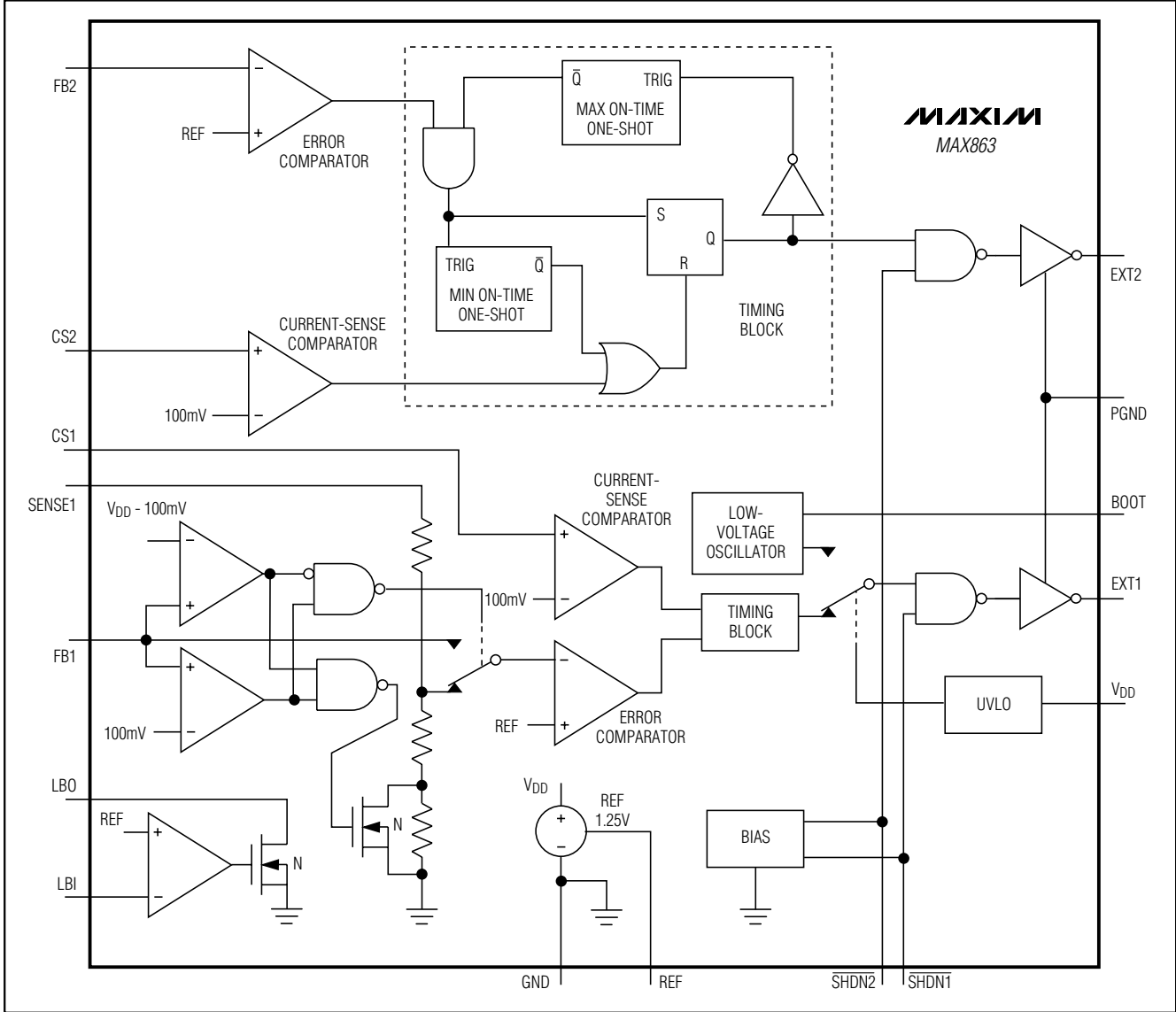

Figure 1. Functional Diagram

The flip-flop resets and turns off the MOSFET when either a) the voltage across the current-sense resistor exceeds 100mV, or b) the 17.5 μ s maximum on-time one-shot trips. When the MOSFET turns off, the magnetic field begins to collapse, and forces current into the output capacitor and load. As the stored energy is transferred to the output, the inductor current ramps down. The output capacitor smoothes out the energy transfer by storing charge when the diode current is

high, then supplying current to the load during the first half of each cycle, maintaining a steady output voltage. Resetting the flip-flop sets the off-time one-shot, disabling the error-comparator output and forcing the MOSFET off for at least 2 μ s to enforce a minimum time for energy transfer to the output. The MAX863 waits until the output voltage drops again before beginning another cycle. The MAX863's switching frequency depends on the load current and input voltage.

Dual, High-Efficiency, PFM, Step-Up DC-DC Controller

MAX863

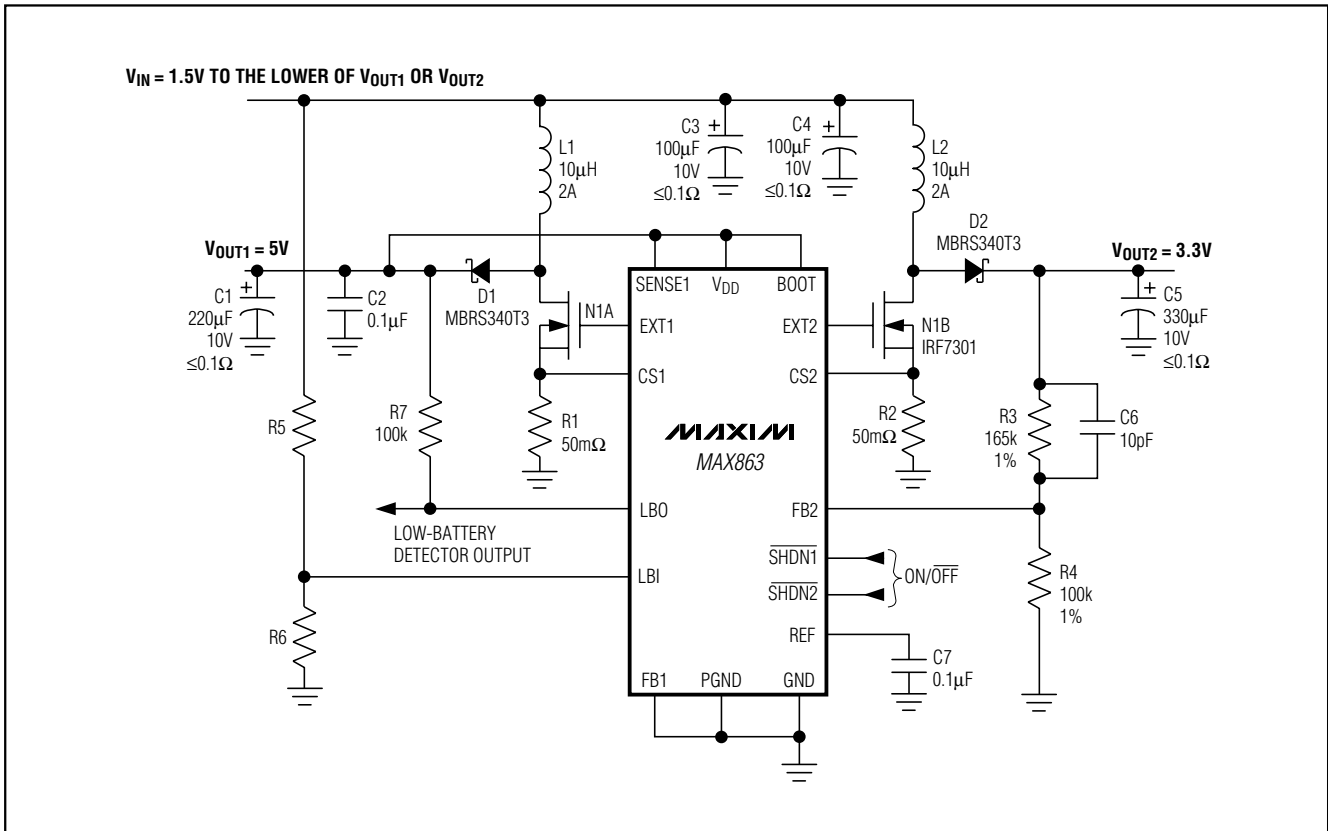

Figure 2. Bootstrapped Typical Operating Circuit

Continuous/Discontinuous-Conduction Modes

Each converter in the MAX863 determines from moment to moment whether to switch or not, waiting until the output voltage drops before initiating another cycle. Under light loads, the inductor current ramps to zero before the next cycle; this is discontinuous-conduction mode. Continuous-conduction mode occurs when the next switching cycle begins while current is still flowing through the inductor. The transition point between discontinuous- and continuous-conduction mode is determined by input and output voltages, and by the size of the inductor relative to the peak switching current. In general, reducing inductance toward the minimum recommended value pushes the transition point closer to the maximum load current. If the inductor value is low enough or the output/input voltage ratio high enough, the DC-DC converter may remain in discontinuous-conduction mode throughout its entire load range.

The MAX863 transitions into continuous-conduction mode in two ways, depending on whether preset or adjustable mode is used and how the external feedback network is compensated. Under light loads, the IC switches in single pulses (Figure 3a). The threshold of transition into continuous-conduction mode is reached when the inductor current waveforms are adjacent to one another, as shown in Figure 3b. As the load increases, the transition into continuous-conduction mode progresses by raising the minimum inductor current (Figures 3c, 3d). Depending on feedback compensation, transition into continuous-conduction mode may also progress with grouped pulses (Figures 3e, 3f). Pulse groups should be separated by less than two or three switching cycles. Output ripple should not be significantly more than the single-cycle no-load case.

Dual, High-Efficiency, PFM, Step-Up DC-DC Controller

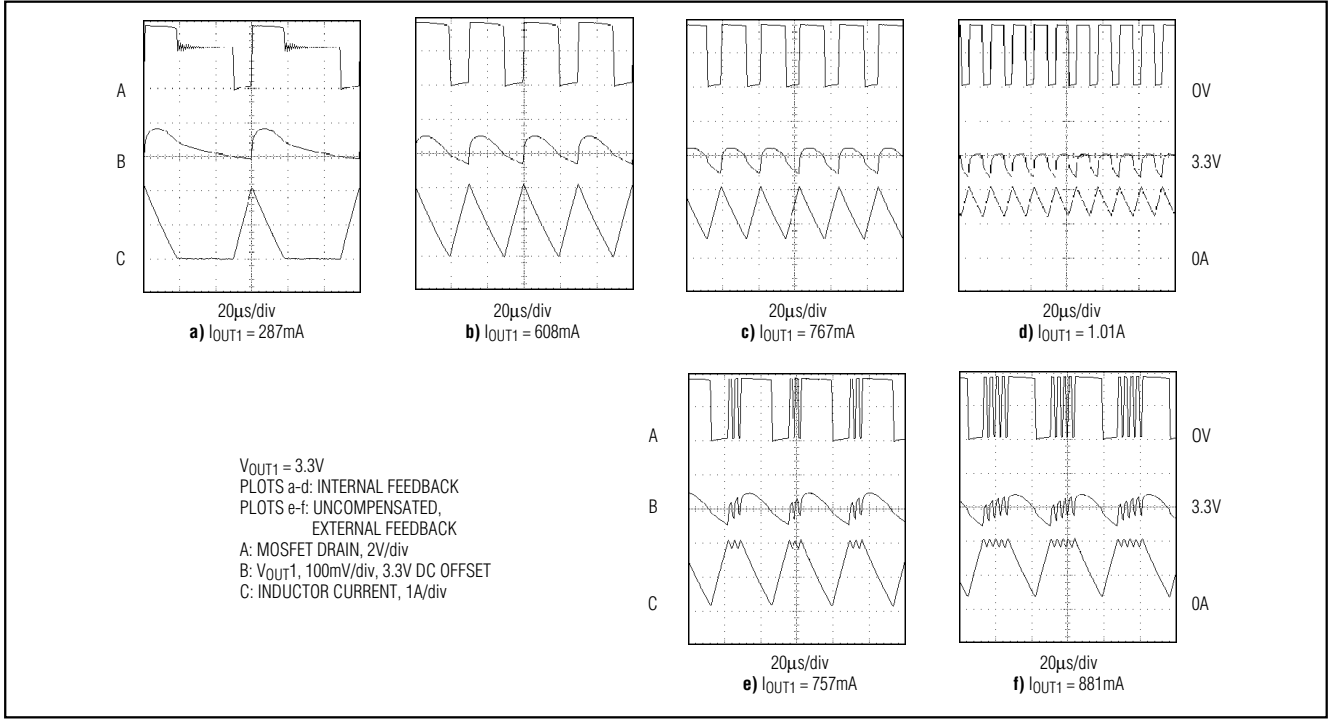

Figures 3a–3f. MAX863 Switching Waveforms During Transition into Continuous Conduction

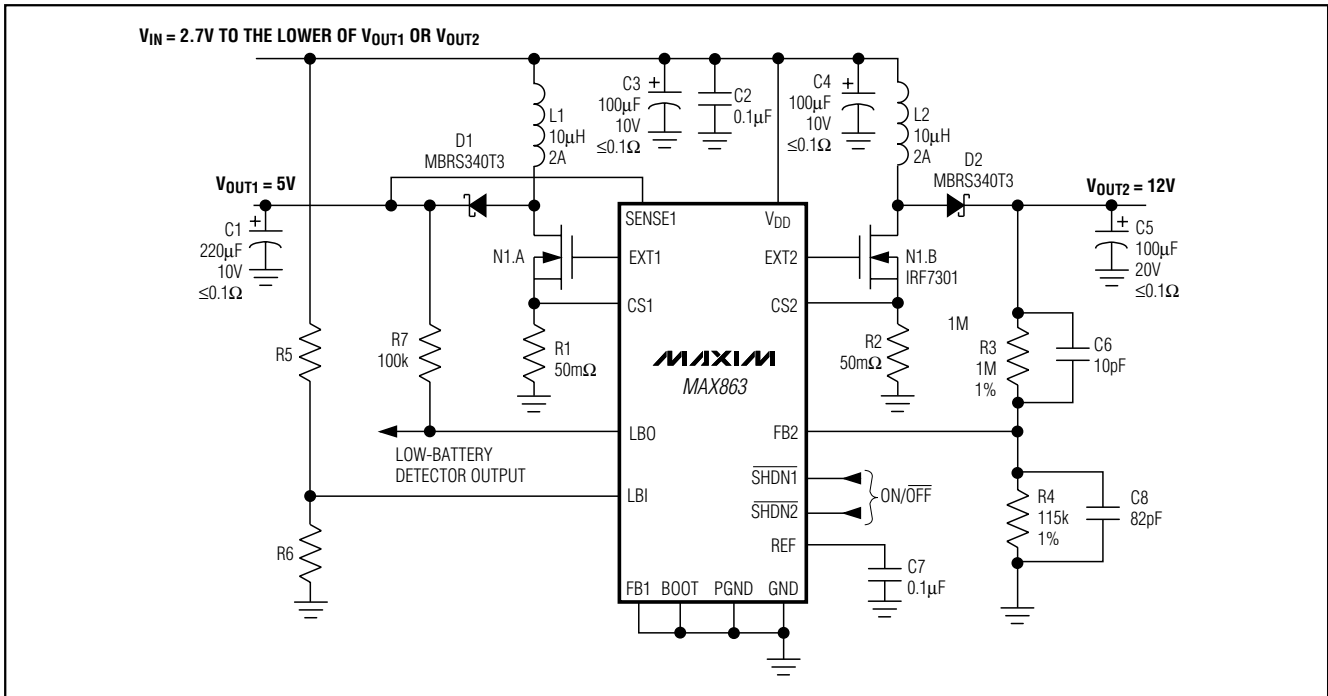

Figure 4a. Non-Bootstrapped Typical Operating Circuit

Dual, High-Efficiency, PFM, Step-Up DC-DC Controller

MAX863

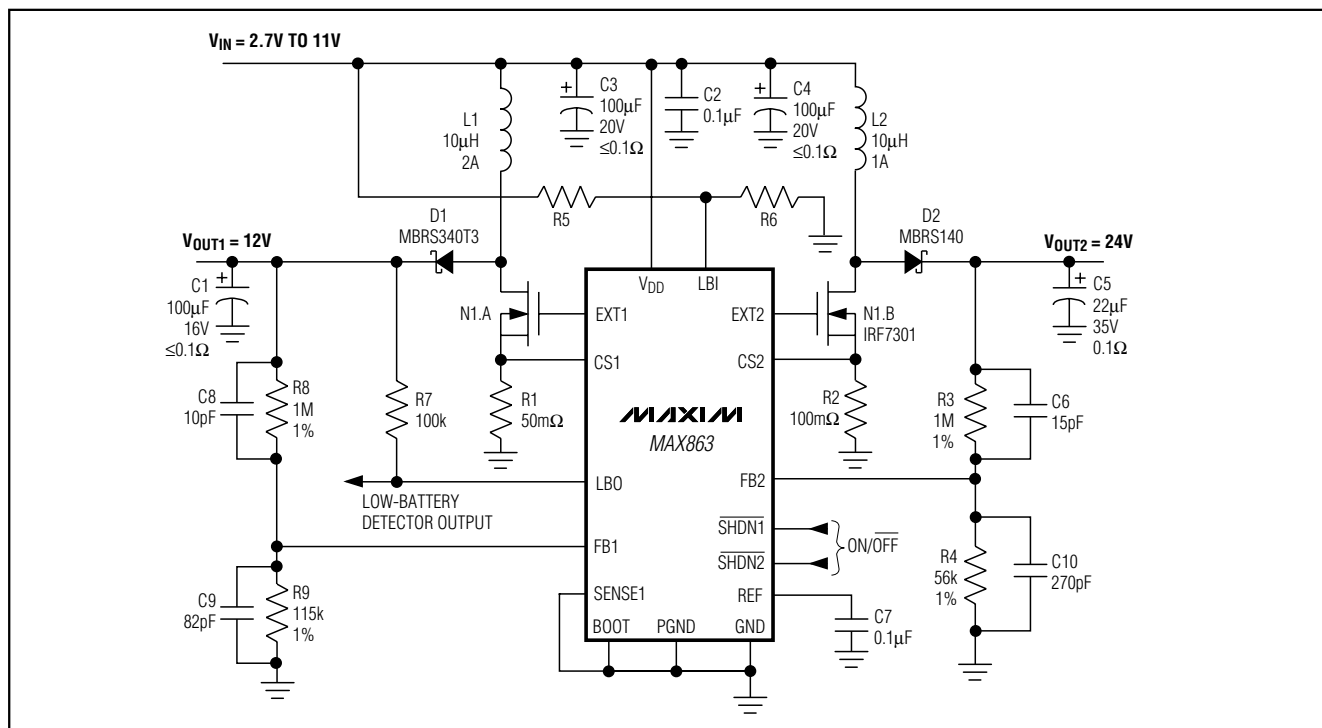

Figure 4b. Adjustable Non-Bootstrapped Typical Operating Circuit

Low-Voltage Start-Up Oscillator (BOOT Pin)

The MAX863 features a low-voltage start-up oscillator that guarantees start-up in bootstrapped configuration down to 1.5V. At these low supply voltages, the error comparator and internal biasing of the IC are locked out. The low-voltage oscillator switches the external MOSFET with around 30% duty cycle until the voltage at V_{DD} rises above 2.7V. At this point, the error comparator and one-shot timing circuitry turn on. The low-voltage oscillator is enabled by connecting the BOOT pin to V_{DD} . When BOOT is high, V_{DD} must be connected to V_{OUT1} .

Use the start-up oscillator in the bootstrapped configuration only, since the MAX863 operates in an open-loop state while the start-up oscillator is active. **When using a non-bootstrapped circuit configuration, connect BOOT to GND** to disable the start-up oscillator. This prevents the output from rising too high when V_{DD} is between 1.5V and 2.7V, such as during power-up and low-battery conditions.

Bootstrapped/Non-Bootstrapped Modes

Figures 2 and 4 show standard applications in bootstrapped and non-bootstrapped modes. In boot-

strapped mode, the IC is powered from the output (V_{DD} is connected to $OUT1$, $BOOT$ is connected to V_{DD}). Bootstrapped-mode operation is useful for increasing the gate drive to the MOSFETs in low-input-voltage applications, since $EXT1$ and $EXT2$ swing from V_{DD} to GND . Increasing the gate-drive voltage reduces MOSFET on-resistance, which improves efficiency and increases the load range. For supply voltages below 5V, bootstrapped mode is recommended. In bootstrapped mode, the output connected to V_{DD} must not exceed 11V. **If BOOT is high, V_{DD} must be connected to $OUT1$.**

In non-bootstrapped mode, the IC is powered by a direct connection from the input voltage to V_{DD} . Since the voltage swing applied to the gate of the external MOSFET is derived from V_{DD} , the external MOSFET on-resistance increases at low input voltages. The minimum input voltage is 2.7V. For operation down to 4V, use logic-level MOSFETs. For lower input voltages, use low-threshold logic-level MOSFETs. When both output voltages are set above 11V, non-bootstrapped mode is mandatory.

Dual, High-Efficiency, PFM, Step-Up DC-DC Controller

Shutdown Mode

The MAX863 has two shutdown inputs useful for conserving power and extending battery life. Driving SHDN1 or SHDN2 low turns off the corresponding DC-DC controller and reduces quiescent current. Driving both shutdown pins low turns off the reference, control, and biasing circuitry, putting the MAX863 in a 1µA shutdown mode. Connect SHDN1 and SHDN2 to VDD for normal operation.

Design Procedure

Boost DC-DC converters using the MAX863 can be designed in a few simple steps to yield a working first-iteration design. All designs should be prototyped and

tested prior to production. Table 1 provides a list of component suppliers.

Two design methods are included. The first uses graphs for selecting the peak current required for 3.3V, 5V, 12V, and 24V outputs. The second uses equations for selecting the peak current and inductor value in circuits with other outputs. When designing high-voltage, flyback, SEPIC, and autotransformer boost circuits, contact Maxim's Applications Department for the appropriate design equations.

Specify Design Objectives

For each of the two outputs, specify the output voltage and maximum load current, as well as maximum and

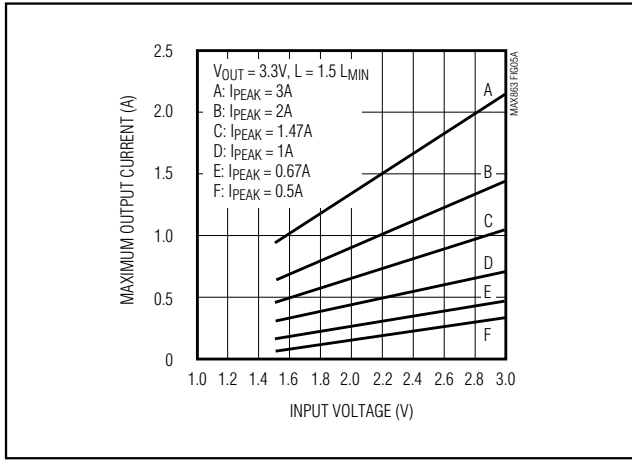

Figure 5a. Maximum Output Current vs. Input Voltage and IPEAK (VOUT = 3.3V)

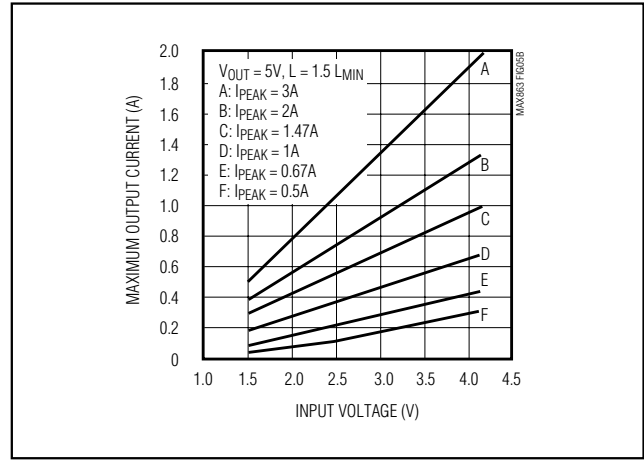

Figure 5b. Maximum Output Current vs. Input Voltage and IPEAK (VOUT = 5V)

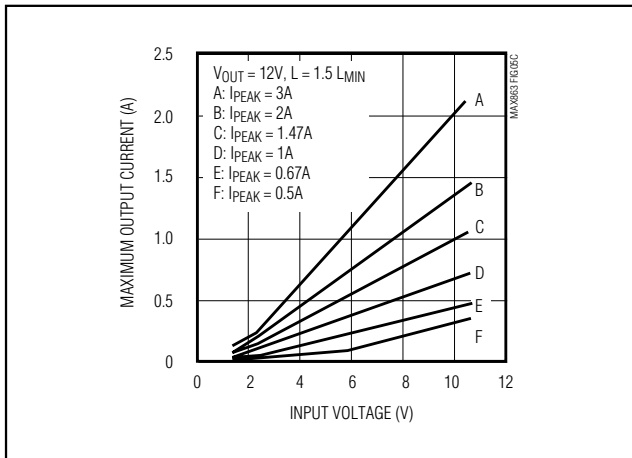

Figure 5c. Maximum Output Current vs. Input Voltage and IPEAK (VOUT = 12V)

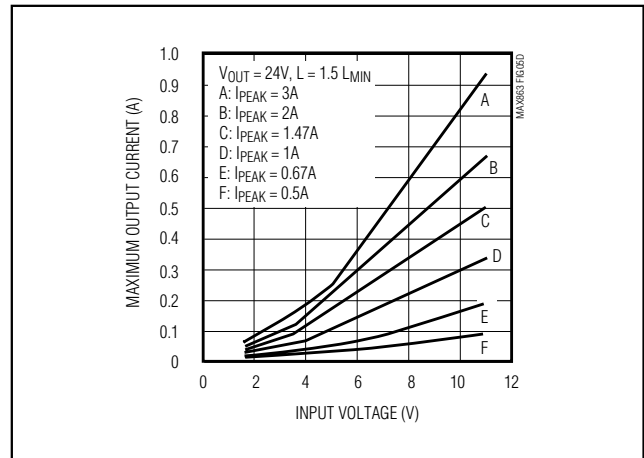

Figure 5d. Maximum Output Current vs. Input Voltage and IPEAK (VOUT = 24V)

Dual, High-Efficiency, PFM, Step-Up DC-DC Controller

minimum input voltages. Estimate the maximum input currents for each output based on the minimum input voltage and desired output power:

$$I_{IN,DC(MAX)} \cong \frac{V_{OUT} \times I_{OUT}}{0.8 \times V_{IN(MIN)}}$$

where 0.8 is chosen as a working value for the nominal efficiency. The power source must be capable of delivering the sum of the maximum input currents of both DC-DC converters.

Determine the Peak Switching Current (Graphical Method)

The peak switching current set by RSENSE determines the amount of energy transferred from the input on each cycle. For 3.3V, 5V, 12V, and 24V output circuits, the peak current can be selected using the output current curves shown in Figures 5a–5d.

Determine the Peak Switching Current and Inductance (Analytical Method)

The following boost-circuit equations are useful when the desired output voltage differs from those listed in Figure 5. They allow trading off peak current and inductor value in consideration of component availability, size, and cost.

Begin by calculating the minimum allowable ratio of inductor AC ripple current to peak current, ξ_{MIN} (Figure 6):

$$\xi_{MIN} = \frac{t_{OFF(MIN)}}{t_{ON(MAX)}} \times \frac{V_{OUT} - V_{IN(MIN)}}{V_{IN(MIN)}}$$

where $t_{OFF(MIN)} = 2\mu s$ and $t_{ON(MAX)} = 17.5\mu s$.

Select a value for ξ greater than ξ_{MIN} . If ξ_{MIN} is less than 1, an acceptable choice is $(\xi_{MIN} + 1) / 2$. If ξ_{MIN} is greater than 1, values between ξ_{MIN} and $2 \times \xi_{MIN}$ are acceptable ($1.5 \times \xi_{MIN}$, for example). Values greater than 1 represent designs with full-load operation in discontinuous-conduction mode.

Now calculate the peak switching current and inductance. If $\xi_{MIN} \leq \xi \leq 1$, use:

$$I_{PEAK} = I_{IN,DC(MAX)} \times \frac{2}{2 - \xi}$$

For $\xi \geq 1\%$, use:

$$I_{PEAK} = 2 \times I_{IN,DC(MAX)} \times \frac{V_{OUT} + V_{IN} \times (\xi - 1)}{V_{OUT}}$$

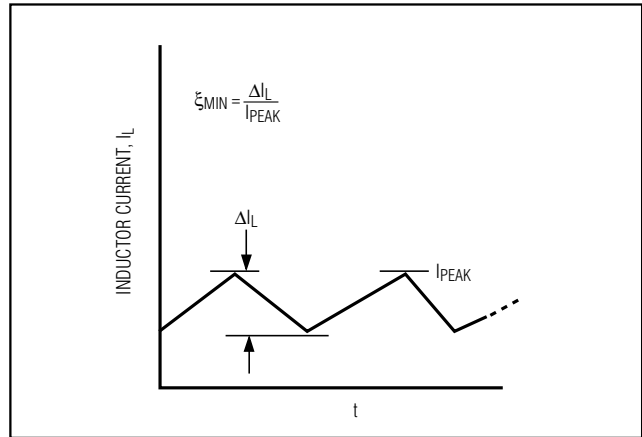

Figure 6. Ratio of Inductor AC Ripple Current to Peak Current

The suggested inductor value is:

$$L \cong \frac{(V_{OUT} - V_{IN(MIN)}) \times t_{OFF(MIN)}}{I_{PEAK} \times \xi}$$

Round L up to the next standard inductor value.

Choose RSENSE

The peak switching current is set by RSENSE (R1 and R2 in Figure 2):

$$R_{SENSE} \leq \frac{V_{CS(MIN)}}{I_{PEAK}} = \frac{85mV}{I_{PEAK}}$$

Verify that you've selected the correct RSENSE by testing the prototype using the minimum input voltage while supplying the maximum output current. If the output voltage droops, then decrease the value of the current-sense resistor and adjust the other components as necessary.

The current-sense resistor must be a small, low-inductance type such as a surface-mount metal-strip resistor. Do not use wire-wound resistors, since their high inductance will corrupt the current feedback signal. In order to allow use of standard resistor values, round RSENSE to the next lowest value.

The current-sense resistor's power rating should be higher than:

$$R_{POWER RATING} = \frac{V_{CS(MAX)}^2}{R_{SENSE}}$$

Dual, High-Efficiency, PFM, Step-Up DC-DC Controller

Select the Inductor Component

Two essential parameters are required for selecting the inductor: inductance and current rating.

Inductance should be low enough to allow the MAX863 to reach the peak current limit during each cycle before the 17.5µs maximum on-time. Conversely, if the inductance is too low, the current will ramp up to a high level before the current-sense comparator can turn the switch off. A practical minimum on-time ($t_{ON(MIN)}$) is 1.5µs.

$$L_{MIN} \geq \frac{V_{IN(MAX)} \times t_{ON(MIN)}}{I_{PEAK}}$$

and:

$$L_{MAX} \geq \frac{V_{IN(MIN)} \times t_{ON(MAX)}}{I_{PEAK}}$$

When selecting I_{PEAK} using the graphs in Figure 5, choose inductance values between 1.3 and 1.7 times the minimum inductance value to provide a good trade-off between switching frequency and efficiency.

The lower of the inductor saturation current rating or heating current rating should be greater than I_{PEAK} :

$$I_{SATURATION} \text{ and } I_{HEATING} > I_{PEAK}$$

The saturation current limit is the current level where the magnetic field in the inductor has reached the maximum the core can sustain, and inductance starts to fall. The heating current rating is the maximum DC current the inductor can sustain without overheating. Disregarding the inductor's saturation current rating is a common mistake that results in poor efficiency, bad regulation, component overheating, or other problems. The resistance of the inductor windings should be comparable to or less than that of the current-sense resistor. To minimize radiated noise in sensitive applications, use a toroid, pot core, or shielded bobbin core inductor.

Choose the MOSFET Power Transistor

Use N-channel MOSFETs with the MAX863. When selecting an N-channel MOSFET, five important parameters are gate-drive voltage, drain-to-source breakdown voltage, current rating, on-resistance ($R_{DS(ON)}$), and total gate charge (Q_G).

The MAX863's EXT1 and EXT2 outputs swing from GND to V_{DD} . To ensure the external N-channel MOSFET is turned on sufficiently, use logic-level MOSFETs when V_{DD} is less than 8V and low-threshold logic-level

MOSFETs when starting from input voltages below 4V. This also applies in bootstrapped mode to ensure start-up.

The MOSFET in a simple boost converter must withstand the output voltage plus the diode forward voltage. Voltage ratings in SEPIC, flyback, and autotransformer-boost circuits are more stringent. Choose a MOSFET with a maximum continuous drain-current rating higher than the current limit set by CS.

The two most significant losses contributing to the MOSFET's power dissipation are I^2R losses and switching losses. Reduce I^2R losses by choosing a MOSFET with low $R_{DS(ON)}$, preferably near the current-sense resistor value or lower.

A MOSFET with a gate charge (Q_G) of 50nC or smaller is recommended for rise and fall times less than 100ns on the EXT pins. Exceeding this limit results in slower MOSFET switching speeds and higher switching losses, due to a longer transition time through the linear region as the MOSFET turns on and off.

Select the Output Diode

Schottky diodes, such as the 1N5817–1N5822 family or surface-mount equivalents, are recommended. Ultra-fast silicon rectifiers with reverse recovery times around 60ns or faster, such as the MUR series, are acceptable but have greater forward voltage drop. Make sure that the diode's peak current rating exceeds the current limit set by R_{SENSE} , and that its breakdown voltage exceeds V_{OUT} . Schottky diodes are preferred for heavy loads, especially in low-voltage applications, due to their low forward voltage. For high-temperature applications, some Schottky diodes may be inadequate due to high leakage currents. In such cases, ultra-fast silicon rectifiers are recommended, although acceptable performance can often be achieved by using a Schottky diode with a higher reverse voltage rating.

Determine Input and Output Filter Capacitors

Low-ESR capacitors are recommended for both input bypassing and output filtering. Capacitor equivalent series resistance (ESR) is a major contributor to output ripple—typically 60% to 90%. Low-ESR tantalum capacitors offer a good tradeoff between price and performance. Ceramic and Sanyo OS-CON capacitors have the lowest ESR. Ceramic capacitors are often a good choice in high-output-voltage applications where large capacitor values may not be needed. Low-ESR aluminum-electrolytic capacitors are tolerable and can be used when cost is the primary consideration; however, standard aluminum-electrolytic capacitors should be avoided.

Dual, High-Efficiency, PFM, Step-Up DC-DC Controller

MAX863

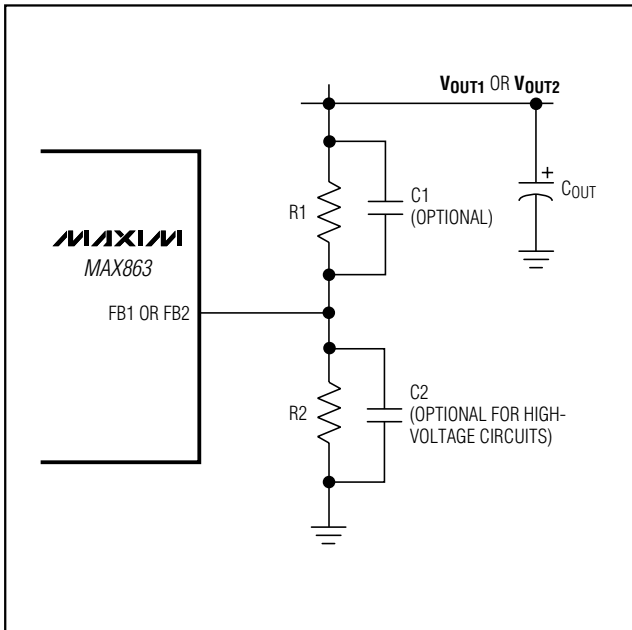

Figure 7. Adjustable Output Circuit

Voltage ripple is the sum of contributions associated with ESR and the capacitor value, as shown below:

$$V_{\text{RIPPLE}} \cong V_{\text{RIPPLE,ESR}} + V_{\text{RIPPLE,C}}$$

To simplify selection, assume that 75% of the ripple results from ESR and that 25% results from the capacitor value. Voltage ripple as a consequence of ESR is approximated by:

$$V_{\text{RIPPLE,ESR}} \cong R_{\text{ESR}} \times I_{\text{PEAK}}$$

so:

$$R_{\text{ESR}} \leq \frac{V_{\text{RIPPLE,ESR}}}{I_{\text{PEAK}}}$$

Estimate input and output capacitor values for a given voltage ripple as follows:

$$C \geq \frac{0.5L \times I_{\text{PEAK}}^2}{V_{\text{RIPPLE,C}} \times V}$$

where V is the input or output voltage, depending on which capacitor is being calculated.

Choose input capacitors with working voltage ratings over the maximum input voltage, and output capacitors with working voltage ratings higher than their respective outputs.

Table 1. Component Suppliers

SUPPLIER	PHONE	FAX
Inductors		
Coilcraft	(847) 639-6400	(847) 639-1469
Coiltronics	(561) 241-7876	(561) 241-9339
Dale Inductors	(605) 668-4131	(605) 665-1627
Sumida USA	(847) 956-0666	(847) 956-0702
MOSFETs and Diodes		
Central Semiconductor	(516) 435-1110	(516) 435-1824
International Rectifier	(310) 322-3331	(310) 322-3232
Motorola	(602) 303-5454	(602) 994-6430
Current-Sense Resistors		
Dale/Vishay	(402) 564-3131	(402) 563-6418
IRC	(512) 992-7900	(512) 992-3377
Electrolytic Capacitors		
AVX	(803) 946-0690	(803) 626-3123
Sanyo USA	(619) 661-6835	(619) 661-1055
Sprague	(603) 224-1961	(603) 224-1430
Large-Value Ceramic Capacitors		
Marcon/United Chemi-Con	(847) 696-2000	(847) 696-9278
TDK	(847) 390-4373	(847) 390-4428
Vishay/Vitramon	(203) 268-6261	(203) 452-5670

Add V_{DD} and REF Bypass Capacitors

Bypass the MAX863 with 0.1μF or higher value ceramic capacitors placed as close to the V_{DD}, REF, and GND pins as possible.

Set the Output Voltage

DC-DC converter 1 operates with a 3.3V, 5V, or adjustable output. For a preset output, connect SENSE1 to OUT1 (Figures 2 and 4a), then set FB1 to V_{DD} for 3.3V operation or to GND for 5V operation. For an adjustable output, connect a resistor voltage divider to the FB1 pin (Figure 7). In adjustable output circuits, connect SENSE1 to GND.

DC-DC converter 2 can be adjusted from very high voltages down to V_{IN} using external resistors connected to the FB2 pin, as shown in Figure 7. Select feedback resistor R2 in the 10kΩ to 500kΩ range. R1 is given by:

$$R1 = R2 \left(\frac{V_{\text{OUT}}}{1.25V} - 1 \right)$$

where 1.25V is the voltage of the internal reference.

Dual, High-Efficiency, PFM, Step-Up DC-DC Controller

Set Feedback Compensation

External voltage feedback to the MAX863 should be compensated for stray capacitance and EMI in the feedback network. Proper compensation is achieved when the MAX863 switches evenly, rather than in widely spaced bursts of pulses with large output ripple. Typically, lead compensation consisting of a 10pF to 220pF ceramic capacitor (C1 in Figure 7) across the upper feedback resistor is adequate. Circuits with V_{OUT} or V_{DD} greater than 7.5V may require a second capacitor across the lower feedback resistor. Initially, choose this capacitor so that $R2C2 = R1C1$. Set the final values of the compensation capacitors based on empirical analysis of a prototype.

PC Board Layout and Routing

High switching speeds and large peak currents make PC board layout an important part of design. Poor layout can cause excessive EMI and ground-bounce, both of which can cause instability or regulation errors by

corrupting the voltage and current-feedback signals. Place power components as close together as possible, and keep their traces short, direct, and wide. Keep the extra copper on the board and integrate it into ground as an additional plane. On multi-layer boards, avoid interconnecting the ground pins of the power components using vias through an internal ground plane. Instead, place the ground pins of the power components close together and route them in a “star” ground configuration using component-side copper, then connect the star ground to the internal ground plane using multiple vias.

The current-sense resistor and voltage-feedback networks should be very close to the MAX863. Noisy traces, such as from the EXT pins, should be kept away from the voltage-feedback networks and isolated from them using grounded copper. Consult the MAX863 evaluation kit manual for a full PC board example.

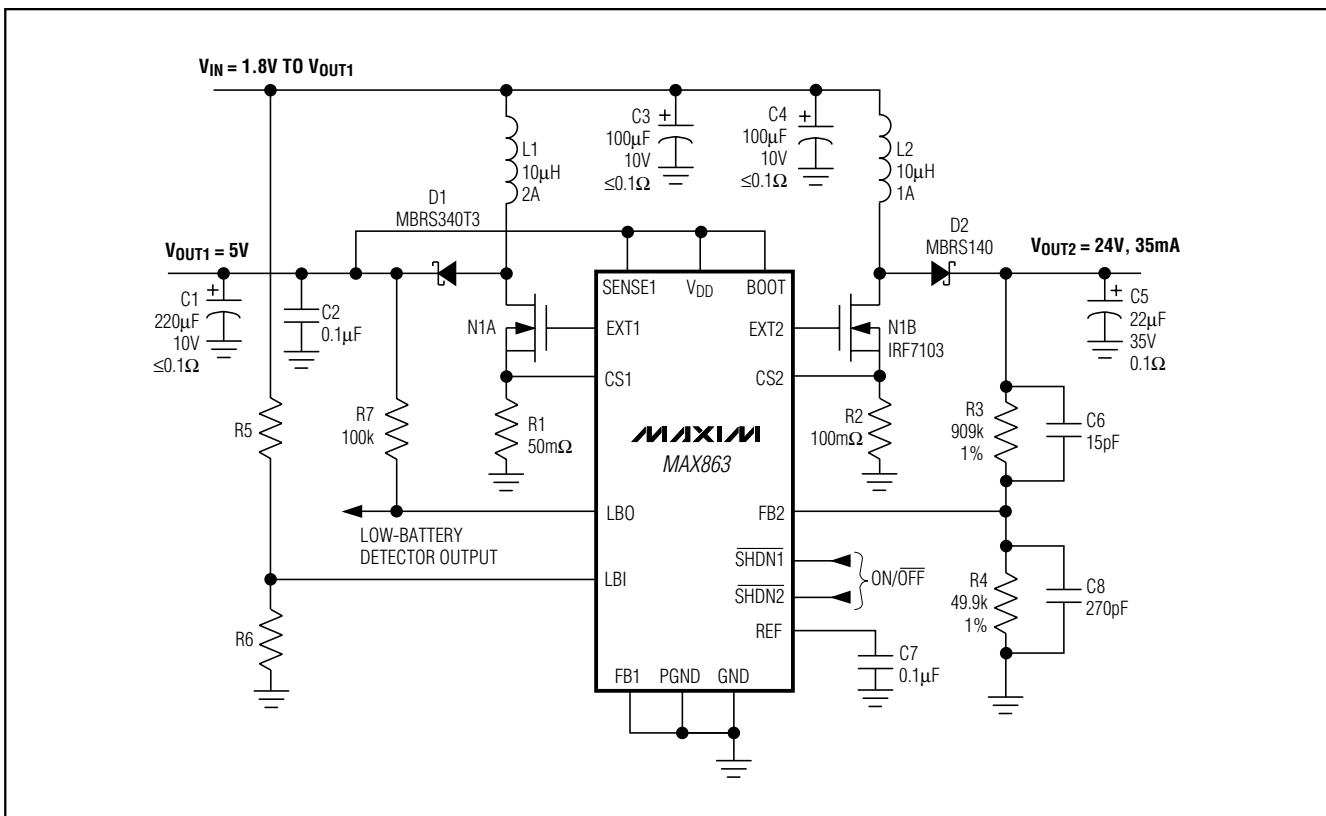

Figure 8. Bootstrapped 3.3V Logic and 24V LCD Bias Supply

Dual, High-Efficiency, PFM, Step-Up DC-DC Controller

MAX863

Applications Information

Low-Input-Voltage Operation

When the voltage at V_{DD} falls and EXT1 or EXT2 approaches the MOSFET gate-to-source threshold voltage, the MOSFET may operate in its linear region and dissipate excessive power. Prolonged operation in this mode may damage the MOSFET if power dissipation ratings are inadequate. This effect is more significant in non-bootstrapped mode, but can occur in bootstrapped mode if the input voltage drops so low that it cannot support the load and causes the output voltage to collapse. To avoid this condition, use logic-level or low-threshold MOSFETs.

Starting Up Under Load

The *Typical Operating Characteristics* show the Bootstrapped-Mode Minimum Start-Up Input Voltage vs. Output Current graph. The MAX863 is not intended to start up under full load in bootstrapped mode with low input voltages.

Application Circuits

Bootstrapped 5V Logic and 24V LCD Bias Supply

The circuit in Figure 8 operates from two AA or AAA cells, and generates 5V (up to 750mA) for logic and 24V (up to 35mA) for an LCD bias supply. OUT1 is used to bootstrap the MAX863 for better MOSFET gate drive. V_{OUT1} can be set to 3.3V if low threshold MOSFETs are used.

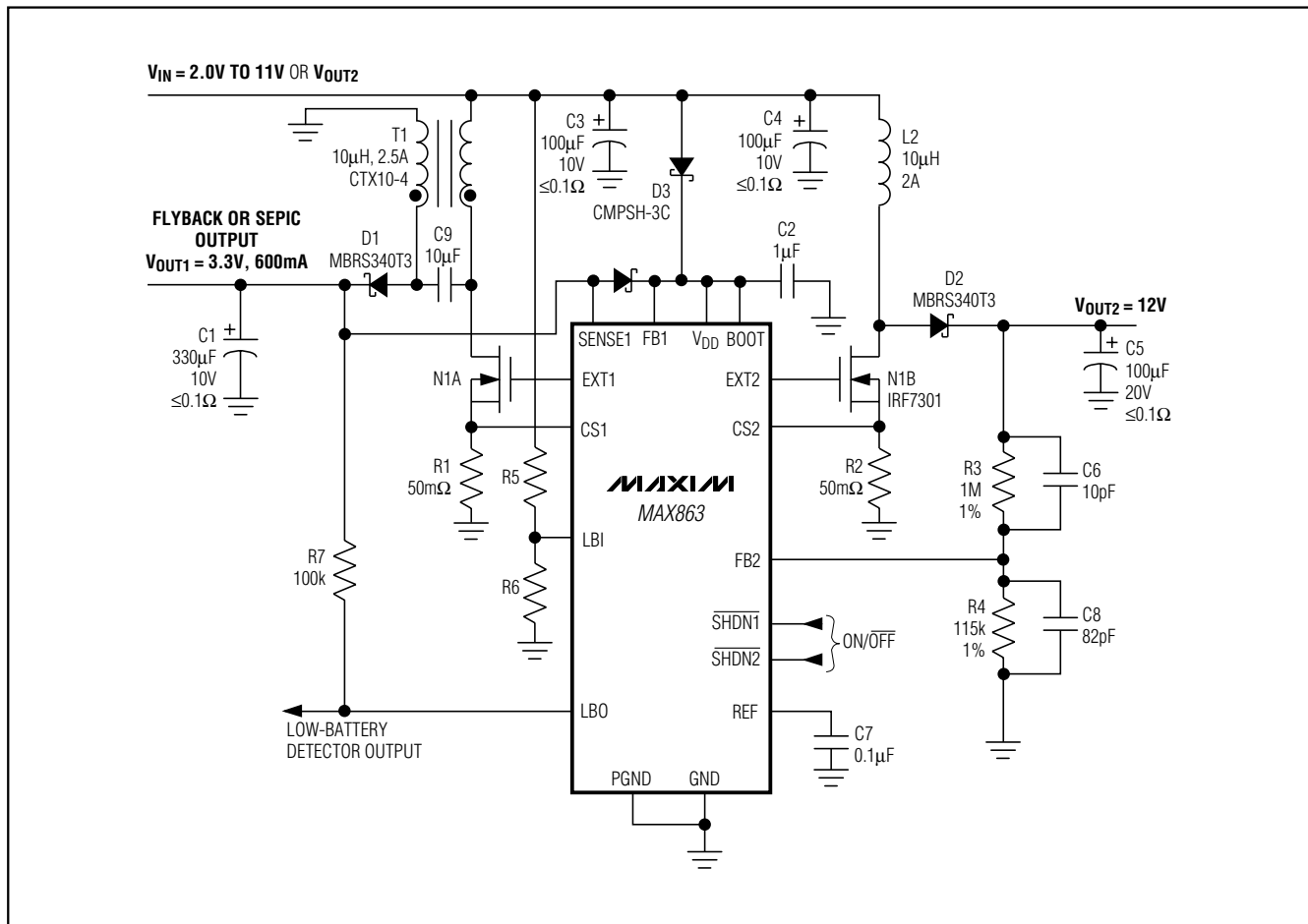

Figure 9. 3-Cell to 3.3V Step-Up/Step-Down Logic Supply with 12V for Flash Memory or Analog Functions

Dual, High-Efficiency, PFM, Step-Up DC-DC Controller

Step-Up/Down SEPIC Converter and 12V Supply

The circuit in Figure 9 provides a buck/boost function for applications where the input voltage range can be greater than or less than V_{OUT1} . It provides 3.3V (up to 600mA) or 5V, as well as 12V (up to 200mA at $V_{IN} = 2.4V$) for powering flash memory or analog functions.

The main output employs a SEPIC topology using a coupled inductor and a capacitor to transfer energy to the output. C2 must be a low-ESR type capable of withstanding high ripple current. Ceramic and Sanyo OS-CONs work well, but low-ESR aluminum electrolytics (which are less costly) are tolerable. Do not use a tantalum capacitor for C2. C2's voltage rating must be higher than the maximum input voltage. The MOSFET must withstand a voltage equal to the sum of the input and output voltages; i.e., when converting 11V to 3.3V, the MOSFET must withstand 14.3V. The dual Schottky diode D3 bootstraps power to the MAX863, allowing use of the low-voltage start-up oscillator, as well as improved gate-drive voltages during normal operation.

Chip Information

TRANSISTOR COUNT: 858
SUBSTRATE CONNECTED TO GND

Package Information

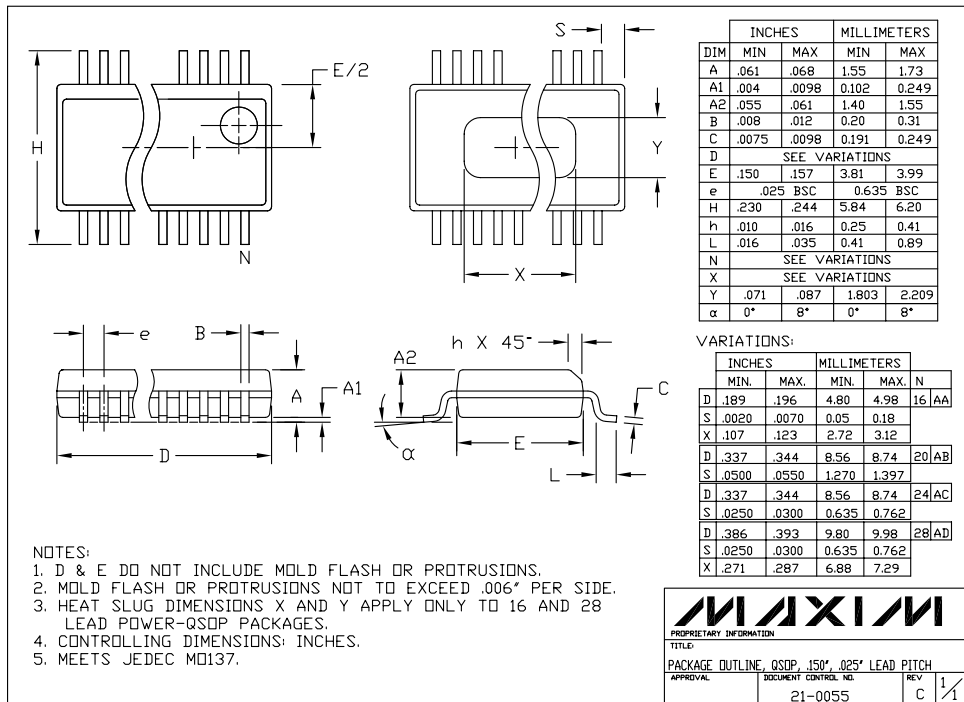

Компания «Life Electronics» занимается поставками электронных компонентов импортного и отечественного производства от производителей и со складов крупных дистрибьюторов Европы, Америки и Азии.

С конца 2013 года компания активно расширяет линейку поставок компонентов по направлению коаксиальный кабель, кварцевые генераторы и конденсаторы (керамические, пленочные, электролитические), за счёт заключения дистрибьюторских договоров

Мы предлагаем:

- Конкурентоспособные цены и скидки постоянным клиентам.
- Специальные условия для постоянных клиентов.
- Подбор аналогов.
- Поставку компонентов в любых объемах, удовлетворяющих вашим потребностям.
- Приемлемые сроки поставки, возможна ускоренная поставка.
- Доставку товара в любую точку России и стран СНГ.
- Комплексную поставку.
- Работу по проектам и поставку образцов.
- Формирование склада под заказчика.
- Сертификаты соответствия на поставляемую продукцию (по желанию клиента).
- Тестирование поставляемой продукции.
- Поставку компонентов, требующих военную и космическую приемку.
- Входной контроль качества.
- Наличие сертификата ISO.

В составе нашей компании организован Конструкторский отдел, призванный помогать разработчикам, и инженерам.

Конструкторский отдел помогает осуществить:

- Регистрацию проекта у производителя компонентов.
- Техническую поддержку проекта.
- Защиту от снятия компонента с производства.
- Оценку стоимости проекта по компонентам.
- Изготовление тестовой платы монтаж и пусконаладочные работы.



Тел: +7 (812) 336 43 04 (многоканальный)
Email: org@lifeelectronics.ru