

LOC	DIST	REVISIONS			
GP	00	REV	DATE	BY	CHK
		A1	08APR2011	AL	CW
		A2	18AUG2014	RG	MC

- △ MATERIAL:
 CAGE: NICKEL SILVER, 0.25 THICK
 HEAT SINK: ALUMINUM
 HEAT SINK CLIP: STAINLESS STEEL
 EMI SPRINGS: COPPER ALLOY
 LIGHT PIPE: CLEAR POLYCARBONATE.
- △ MINIMUM PITCH DIMENSION.
3. MATES WITH SFF-8436 COMPATIBLE TRANSCEIVER.
- △ REFERENCE APPLICATION SPEC 114-13217 FOR RECOMMENDED DRILL HOLE DIAMETER AND PLATING THICKNESS.
- △ DATUMS AND BASIC DIMENSIONS ESTABLISHED BY CUSTOMER.
6. MINIMUM PC BOARD THICKNESS:
 SINGLE SIDED = 1.45mm (shown, pg. 4)
 DOUBLE SIDED = 2.2mm.
- △ HEATSINK, LIGHT PIPE, AND CLIP SHIPPED ASSEMBLED TO CAGE ASSEMBLY. CAGE ASSEMBLY MAY BE PRESSED INTO THE PCB AS SHIPPED.
- △ DATUM -A- IS TOP SURFACE OF HOST BOARD.
- △ SURFACE TRACES PERMITTED WITHIN THIS LENGTH EXCEPT WHERE CAGE STANDOFFS, SHOWN IN DETAIL J, CONTACT PC BOARD.
- △ DIMENSION APPLIES WITH MODULE INSTALLED IN CAGE.
11. MAXIMUM HEIGHT OF CUSTOMER SUPPLIED LED OFF BOARD: 1.70mm.
- △ DATE CODE (YYWW) MARKED ON TOP OF CAGE AND CONCEALED BY HEAT SINK APPLIES TO CAGE ASSEMBLY ONLY.
- △ HEAT SINK AND CLIP SHIPPED ASSEMBLED TO CAGE ASSEMBLY. CAGE ASSEMBLY MAY BE PRESSED INTO THE PCB AS SHIPPED. LIGHT PIPE MUST BE ASSEMBLED BY CUSTOMER AFTER THE CAGE IS SEATED ON THE PCB.
- △ SPRING FINISH: 0.8um MIN TIN OVER 0.8um MIN NICKEL.
 HEAT SINK FINISH: NICKEL.
 NON-PLATED EDGES PERMISSIBLE.
15. PRODUCT HAS NOT COMPLETED QUALIFICATION TESTING.

Sn42Bi58 SOLDER
 6 PLACES

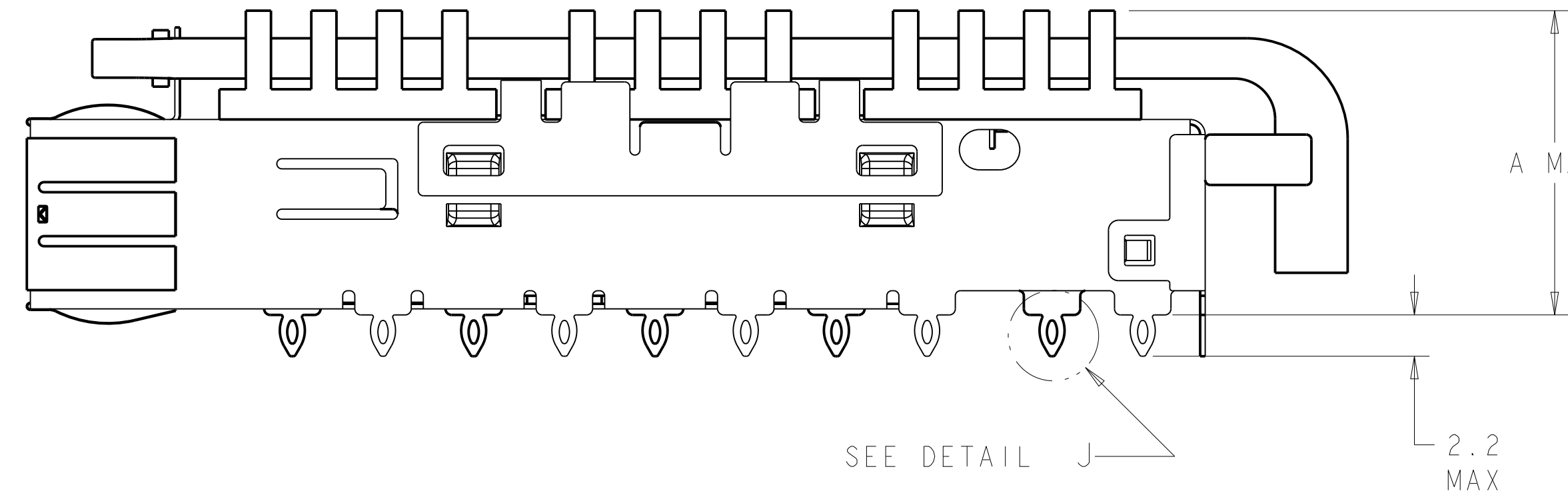
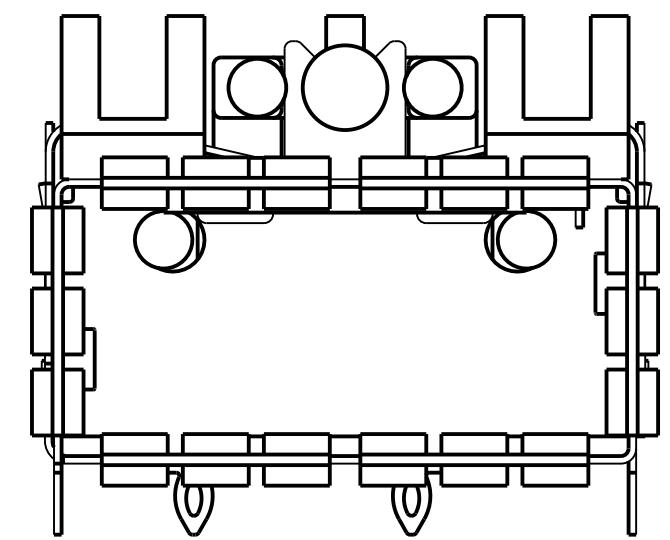
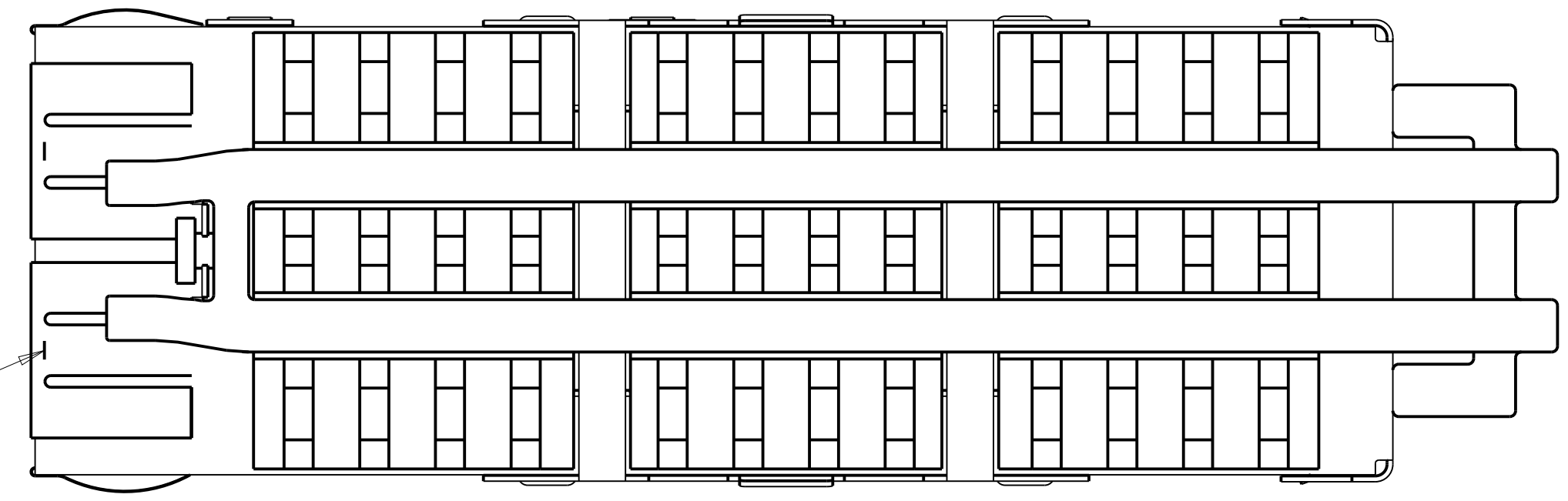

SEE DETAIL J

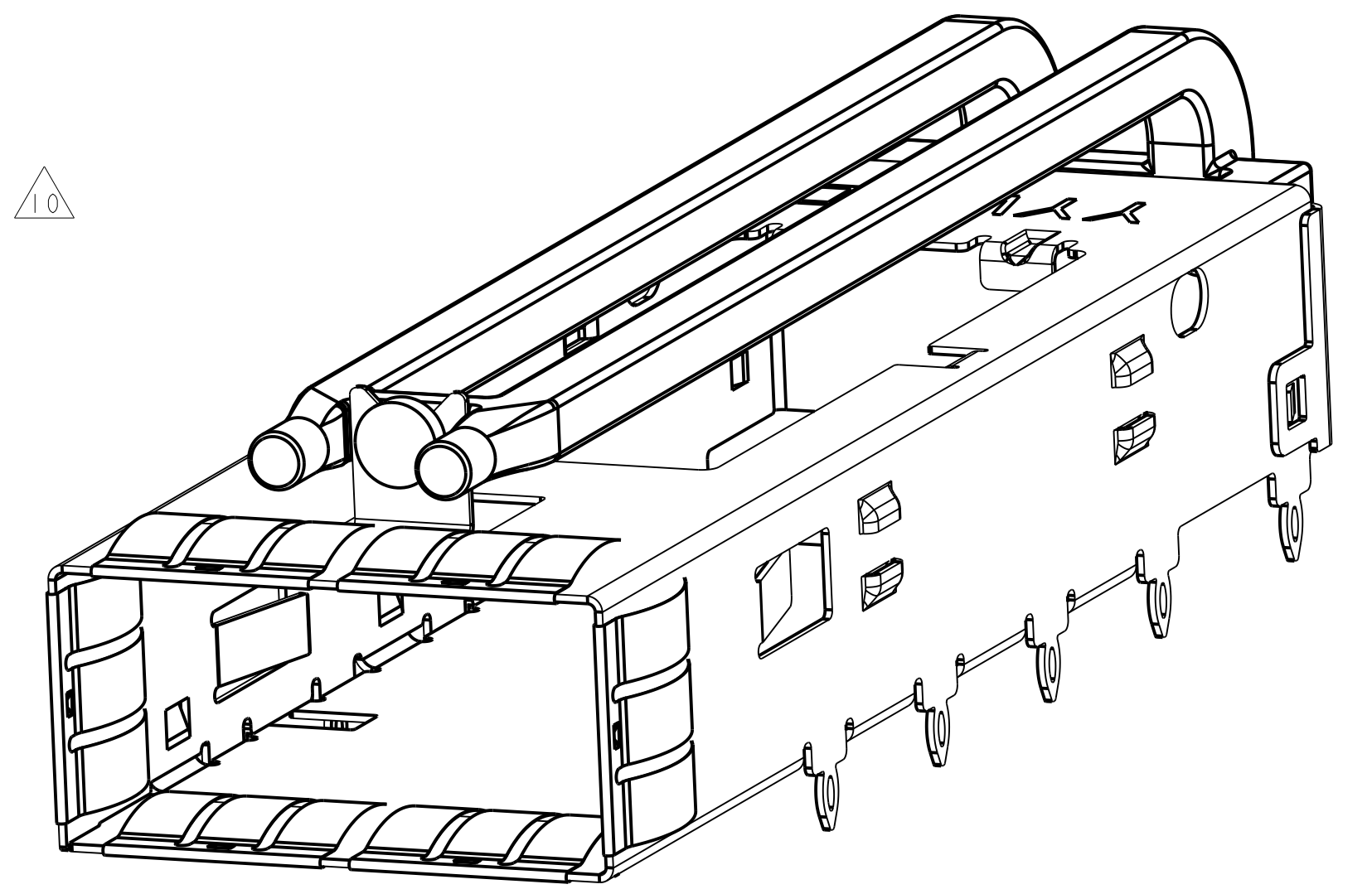

1888971-4 AS SHOWN
 SCALE 5:1

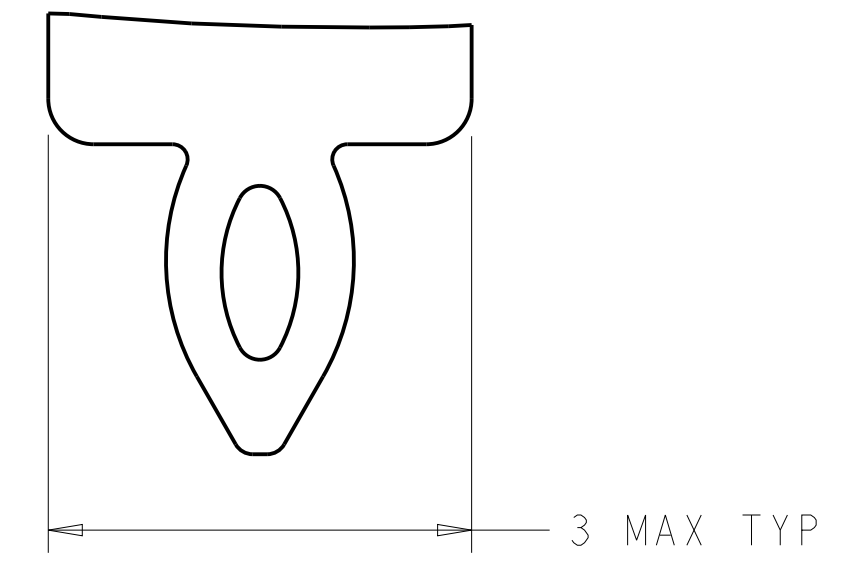

DETAIL J
 SCALE 20:1

DESCRIPTION	PART NUMBER
- NO HEAT SINK	1888971-4
13.7 PCI HEAT SINK	1888971-3
23.0 NETWORKING HEAT SINK	1888971-2
16.0 SAN HEAT SINK (SHOWN)	1888971-1

THIS DRAWING IS A CONTROLLED DOCUMENT.		OWN: C. VALENTINI 22FEB2007	TE Connectivity	
DIMENSIONS: mm		CHK: E. BRIGHT 22FEB2007		
TOLERANCES UNLESS OTHERWISE SPECIFIED:		APVD: E. BRIGHT 22FEB2007	NAME: CAGE ASSEMBLY, THRU BEZEL, QSFP, W/ HEAT SINK AND DOUBLE LIGHT PIPE	
0 PLC	±0.13	PRODUCT SPEC	108-2286	
1 PLC	±0.13	APPLICATION SPEC	114-13217	
2 PLC	±0.13	SIZE	CAGE CODE DRAWING NO	
3 PLC	±0.013	WEIGHT	A100779C=1888971	
4 PLC	±0.013	Customer Drawing	SCALE 4:1 SHEET 1 OF 4 REV A2	
ANGLES	±0.0001			
FINISH				

LOC		DIST		REVISONS			
GP	00	P	LTN	DESCRIPTION	DATE	DMN	APVD
		-		SEE SHEET 1	-	-	-

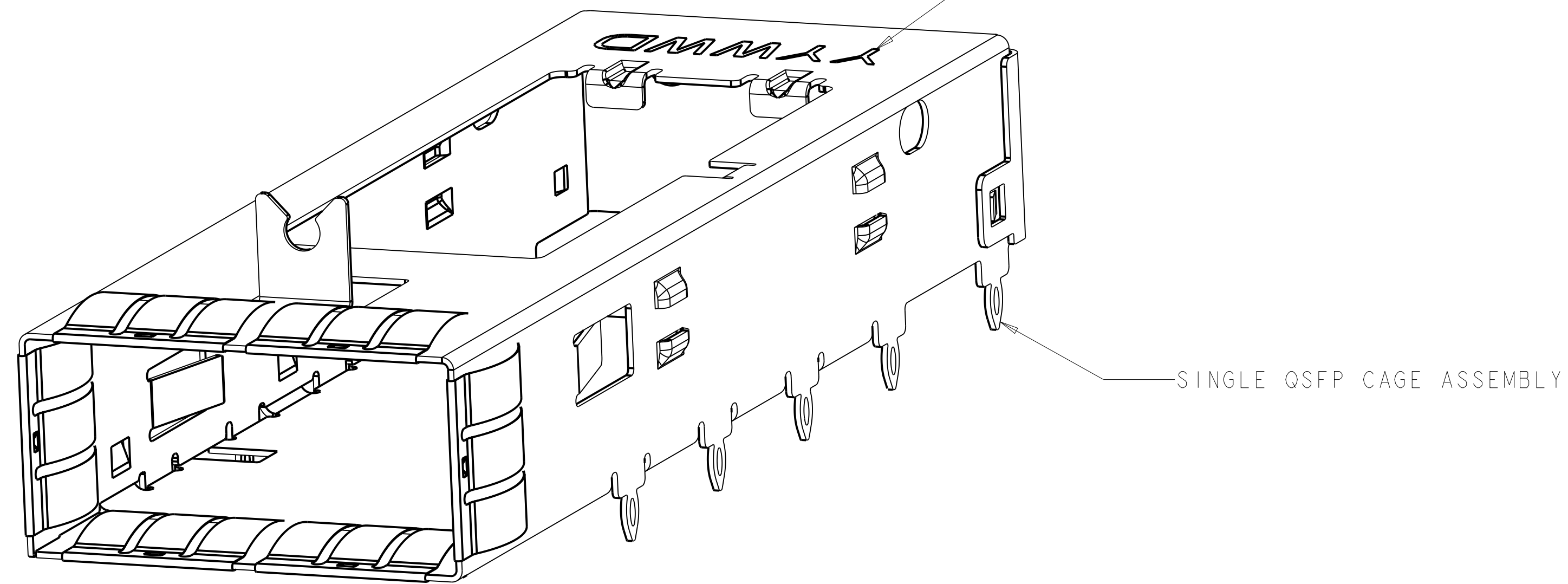
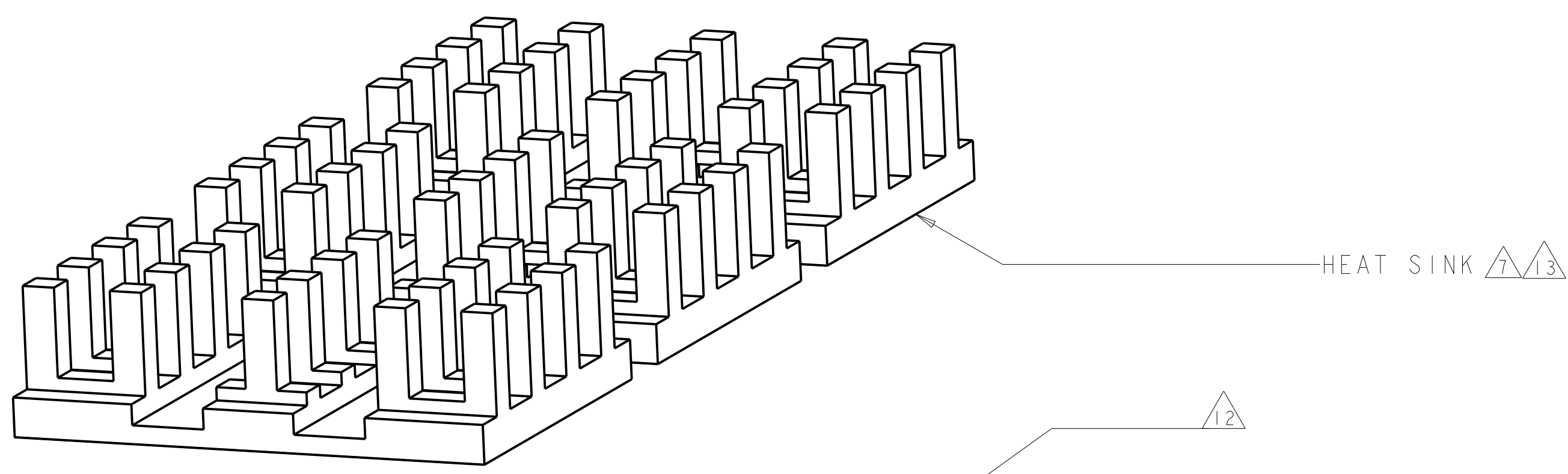
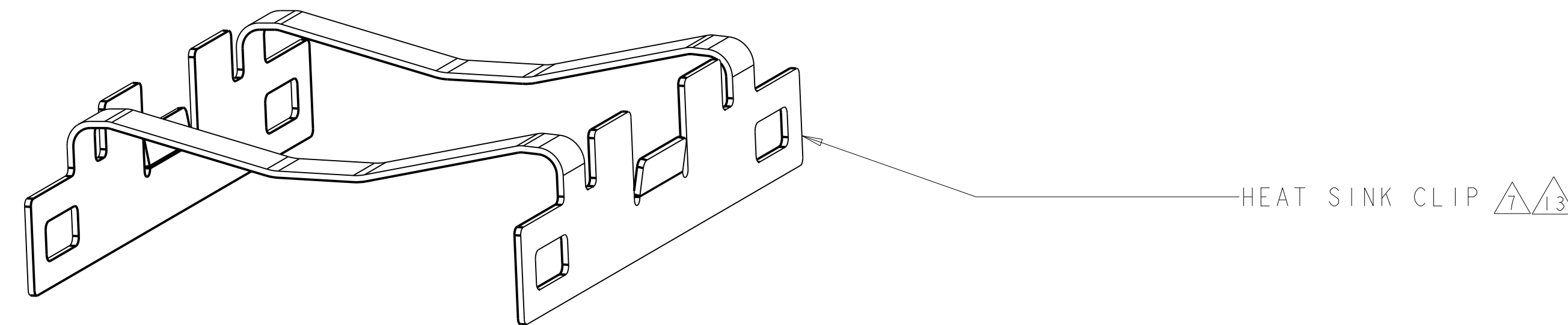
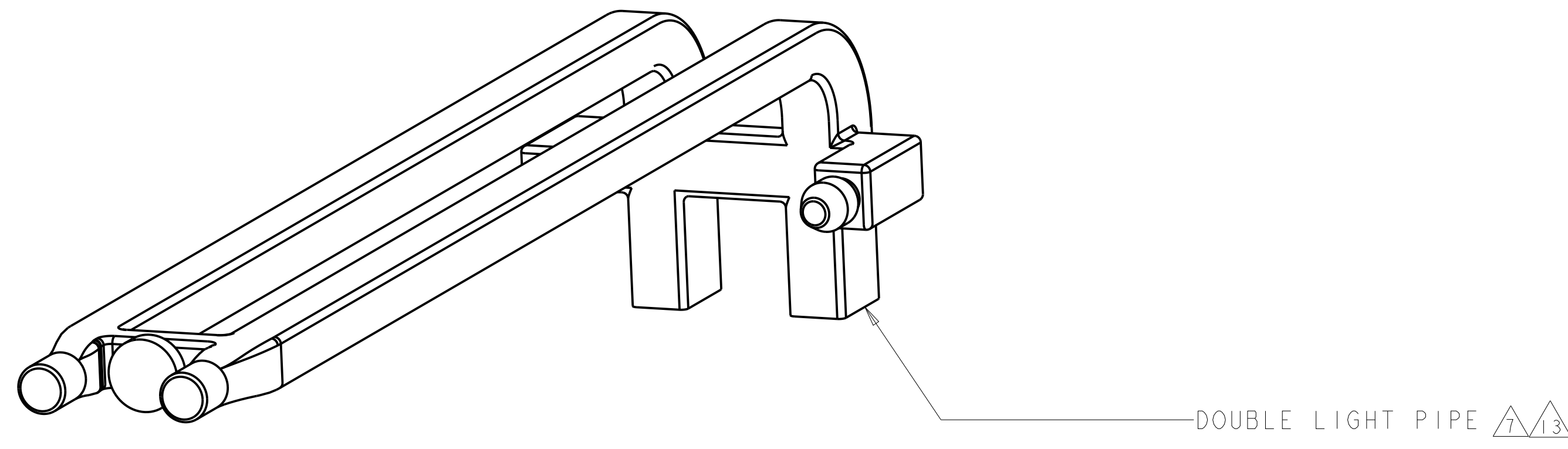

ISOMETRIC EXPLODED VIEW
 SCALE 6:1

THIS DRAWING IS A CONTROLLED DOCUMENT.		DMN C. VALENTINE 22FEB2007	TE Connectivity
DIMENSIONS: mm		CHK E. BRIGHT 22FEB2007	
TOLERANCES UNLESS OTHERWISE SPECIFIED: 0 PLC ± 0.13 1 PLC ± 0.13 2 PLC ± 0.13 3 PLC ± 0.13 4 PLC ± 0.013 ANGLES ± 0.0001		APVD E. BRIGHT 22FEB2007	NAME CAGE ASSEMBLY, THRU BEZEL, QSFP, W/ HEAT SINK AND DOUBLE LIGHT PIPE
		PRODUCT SPEC 108-2286	RESTRICTED TO
MATERIAL		APPLICATION SPEC 114-13217	SIZE A100779C=1888971
FINISH		WEIGHT	SCALE 4:1 SHEET 2 OF 4 REV A2
		Customer Drawing	

LOC		DIST		REVISIONS			
P	LTN	DESCRIPTION	DATE	DMN	APVD		
-	-	SEE SHEET 1	-	-	-		

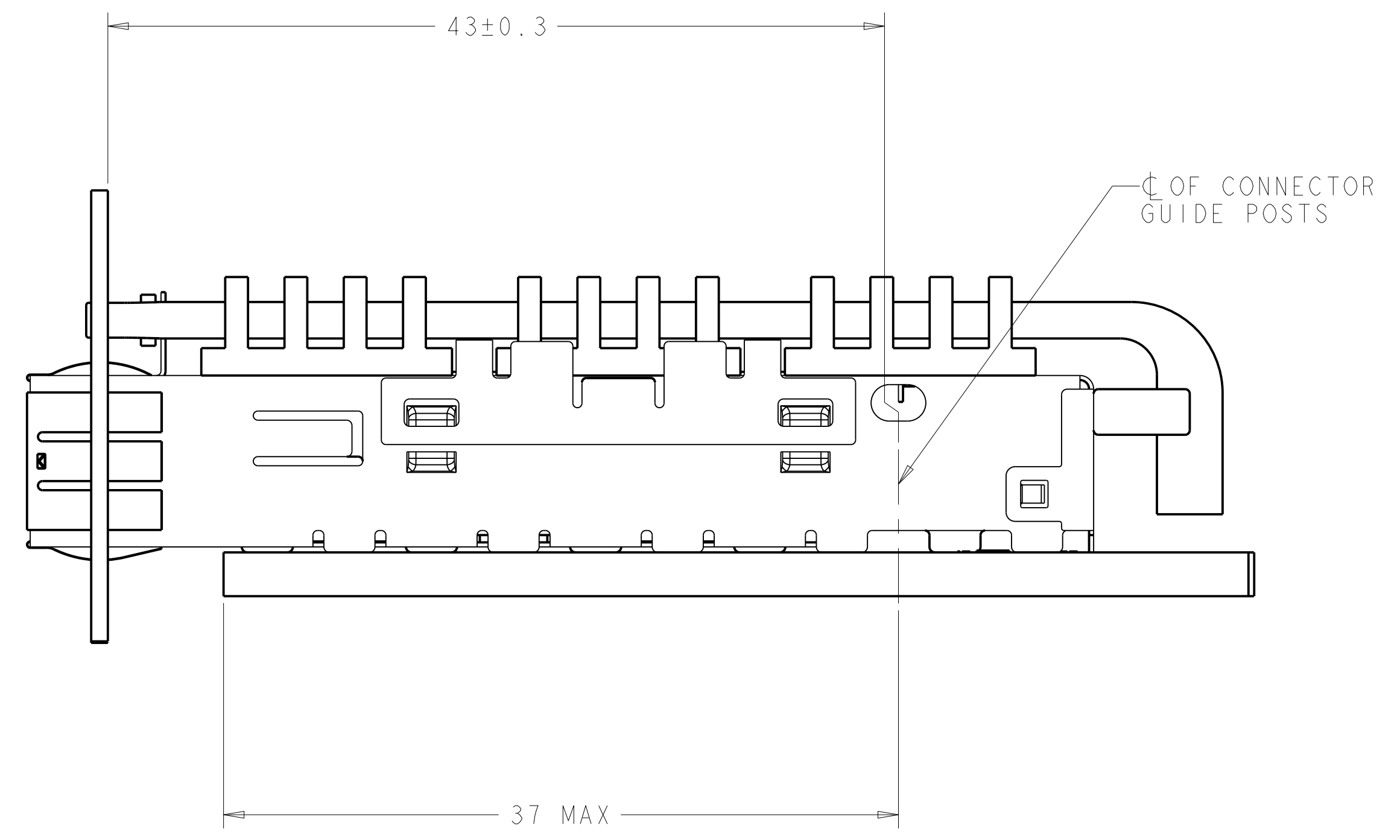
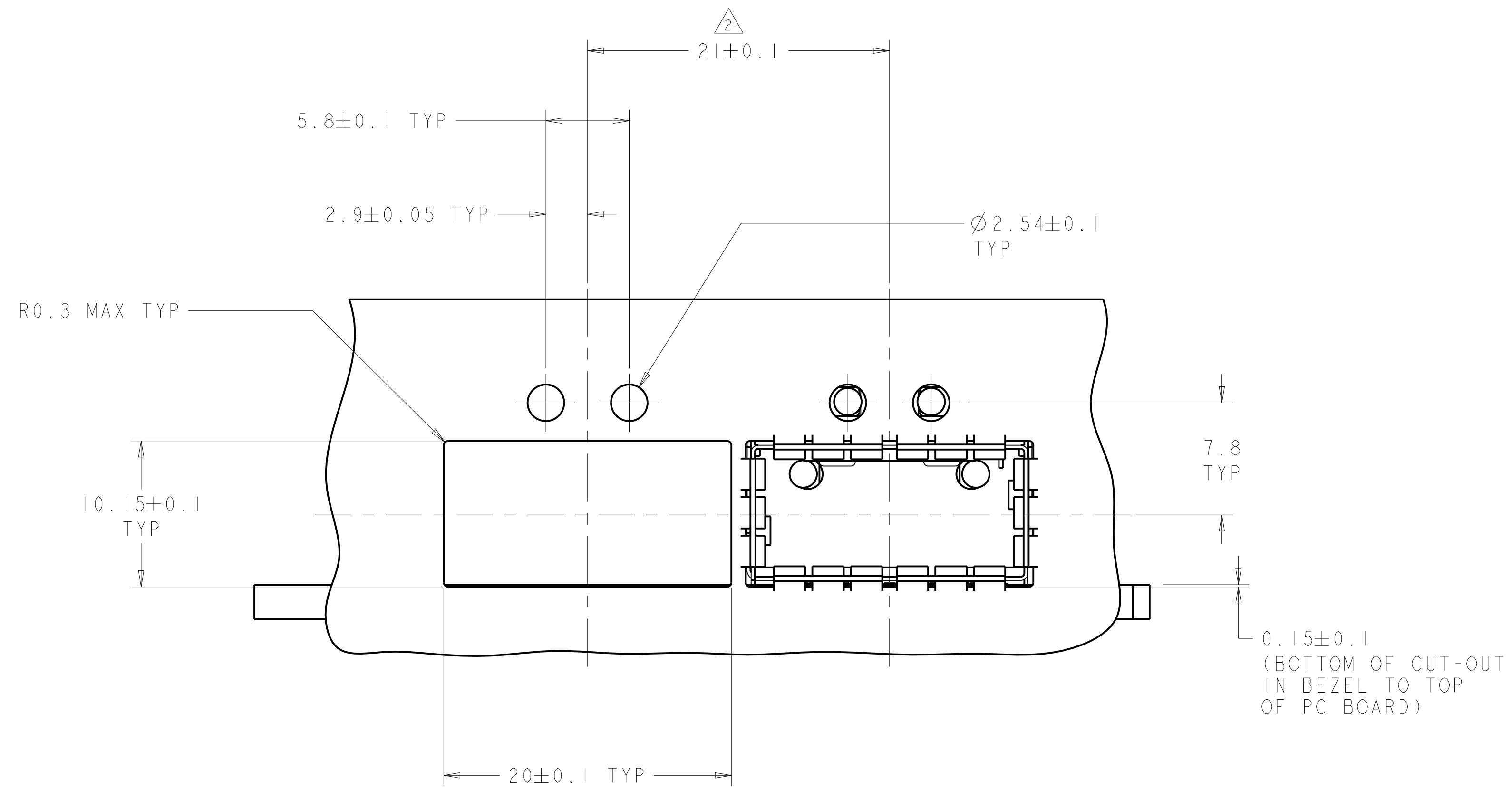

THIS DRAWING IS A CONTROLLED DOCUMENT.		DMN C. VALENTINE 22FEB2007	STE TE Connectivity	
		CHK E. BRIGHT 22FEB2007		
DIMENSIONS:		APVD E. BRIGHT 22FEB2007	NAME CAGE ASSEMBLY, THRU BEZEL, QSFP, W/ HEAT SINK AND DOUBLE LIGHT PIPE	
mm	TOLERANCES UNLESS OTHERWISE SPECIFIED:	PRODUCT SPEC	SIZE A100779C=1888971	
	0 PLC ± 0.13	108-2286	RESTRICTED TO	
	1 PLC ± 0.13	APPLICATION SPEC		
	2 PLC ± 0.13	114-13217		
	3 PLC ± 0.013	WEIGHT		
	4 PLC ± 0.001	Customer Drawing		
	ANGLES ± 0.0001	SCALE 4:1	SHEET 3 OF 4 REV A2	
MATERIAL	FINISH			

LOC	DIST	REV	DATE	BY	APPV
GP	00				

REVISIONS			
REV	DATE	BY	APPV
-	-	-	-
-	-	-	-

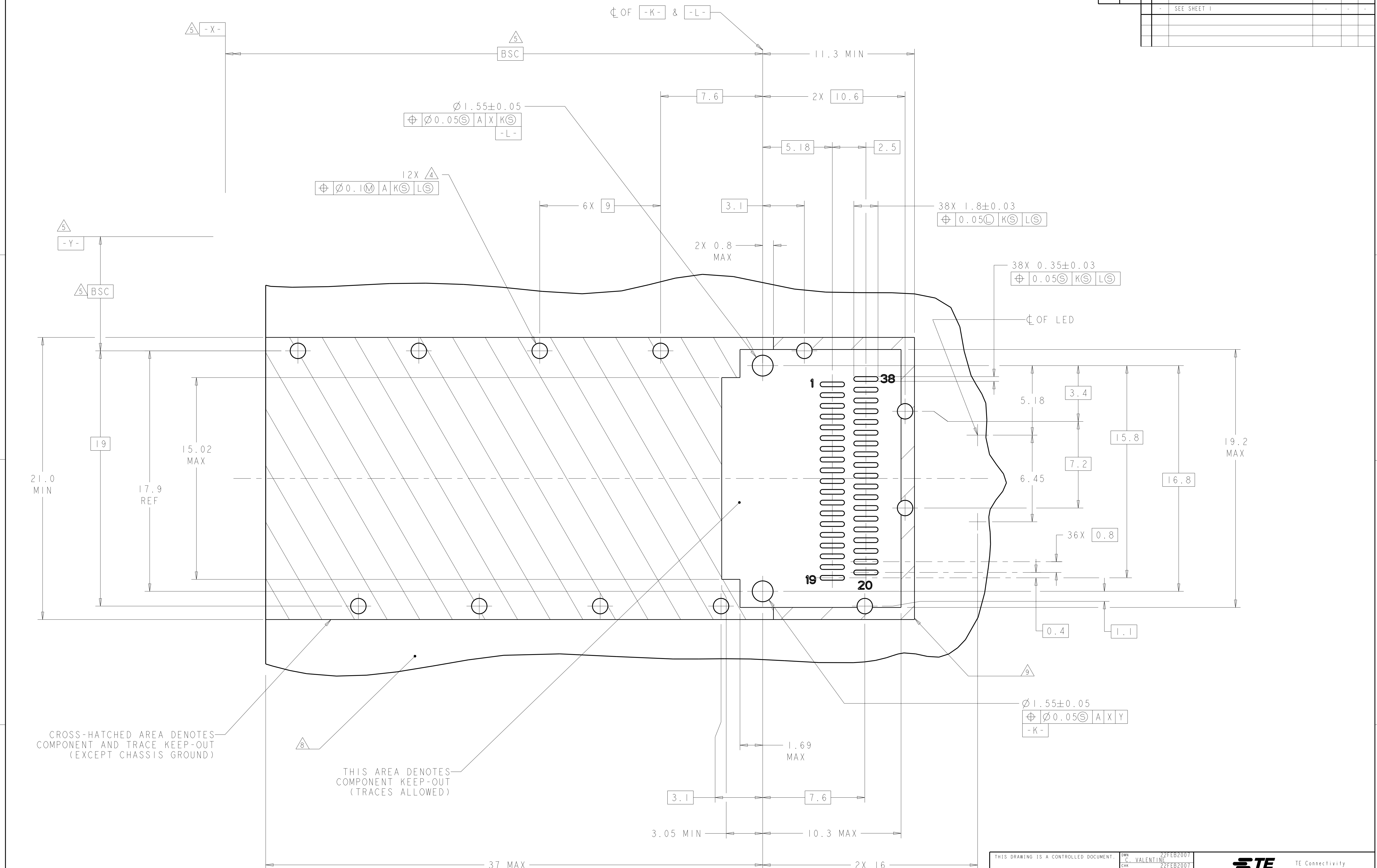

CROSS-HATCHED AREA DENOTES COMPONENT AND TRACE KEEP-OUT (EXCEPT CHASSIS GROUND)

THIS AREA DENOTES COMPONENT KEEP-OUT (TRACES ALLOWED)

RECOMMENDED PC BOARD LAYOUT
 SCALE 8:1

THIS DRAWING IS A CONTROLLED DOCUMENT.		OWN: C. VALENTINE 22FEB2007	TE Connectivity
DIMENSIONS: mm		CHK: E. BRIGHT 22FEB2007	
TOLERANCES UNLESS OTHERWISE SPECIFIED:		APVD: E. BRIGHT 22FEB2007	NAME: CAGE ASSEMBLY, THRU BEZEL, QSFPP, W/ HEAT SINK AND DOUBLE LIGHT PIPE
0 PLC	±0.13	PRODUCT SPEC	108-2286
2 PLC	±0.13	APPLICATION SPEC	114-13217
3 PLC	±0.13	WEIGHT	Customer Drawing
4 PLC	±0.013	SCALE	4:1
ANGLES	±0.0001	SHEET	4 OF 4
FINISH		REV	A2

Компания «Life Electronics» занимается поставками электронных компонентов импортного и отечественного производства от производителей и со складов крупных дистрибьюторов Европы, Америки и Азии.

С конца 2013 года компания активно расширяет линейку поставок компонентов по направлению коаксиальный кабель, кварцевые генераторы и конденсаторы (керамические, пленочные, электролитические), за счёт заключения дистрибьюторских договоров

Мы предлагаем:

- Конкурентоспособные цены и скидки постоянным клиентам.
- Специальные условия для постоянных клиентов.
- Подбор аналогов.
- Поставку компонентов в любых объемах, удовлетворяющих вашим потребностям.
- Приемлемые сроки поставки, возможна ускоренная поставка.
- Доставку товара в любую точку России и стран СНГ.
- Комплексную поставку.
- Работу по проектам и поставку образцов.
- Формирование склада под заказчика.
- Сертификаты соответствия на поставляемую продукцию (по желанию клиента).
- Тестирование поставляемой продукции.
- Поставку компонентов, требующих военную и космическую приемку.
- Входной контроль качества.
- Наличие сертификата ISO.

В составе нашей компании организован Конструкторский отдел, призванный помогать разработчикам, и инженерам.

Конструкторский отдел помогает осуществить:

- Регистрацию проекта у производителя компонентов.
- Техническую поддержку проекта.
- Защиту от снятия компонента с производства.
- Оценку стоимости проекта по компонентам.
- Изготовление тестовой платы монтаж и пусконаладочные работы.



Тел: +7 (812) 336 43 04 (многоканальный)

Email: org@lifeelectronics.ru