

# VSC8479

VITESSE

## 9.95 Gbps to 11.3 Gbps 16-bit Transceiver



### FEATURES:

- ▶ 16:1 Mux/Demux Transceiver With Integrated Clock Multiplier Unit, and Clock and Data Recovery Unit with Limiting Amplifier
- ▶ 0.13µm CMOS Process Technology
- ▶ XFI Output Compliance Mode for XFP Modules
- ▶ Programmable Input Signal Bandwidth Equalization (EQ)
  - Enhanced Optical Performance
  - Enhanced XFI Stressed Eye Performance
- ▶ Built-in Self-test Generation and Error Detection:
  - Industry Standard PRBS Generation and Detection
  - User Defined Patterns
- ▶ Full Support for 300-Pin MSA Transponder Modules:
  - Multiple Reference Clock Source Inputs and Selectable Frequencies
  - Facility and Equipment Loopback Modes
  - Support for Line Timing Mode with Clock Clean-up
  - Loss of Lock (LOL) and FIFO Alarm Outputs
  - Adjustable Loss of Signal (LOS) Alarm
- ▶ Two-wire or SPI Micro-controller Serial Interface Port (selectable)
  - Programmable Registers for Access to All Control/Status Signals
- ▶ TxRef Clock, RxRef Clock and ExRef Clock Sources
  - Flexible Reference Clock Routing
  - Reference Clock "Clean-up" Phase Detector
- ▶ Selectable Duobinary Modulation Pre-Coder
- ▶ Programmable High-speed Input Voltage Offset Adjust
- ▶ High-speed Data Inversion and Low-Speed Bit Order Swap
- ▶ High-speed CML Clock Output with Power Down Mode

### SPECIFICATIONS:

- ▶ Continuous Frequency of Operation: 9.95 Gbps to 11.3 Gbps
- ▶ Exceeds SONET Band Jitter Generation Performance (35 mUI)
- ▶ Better than 2X Margin to the OC-192 Jitter Tolerance SONET Mask
- ▶ Excellent Crosstalk Immunity and Asynchronous Tx and Rx Operation
- ▶ 10mV Input Data Sensitivity (differential)
- ▶ OIF 99.102.8 LVDS Compatible Parallel Data Inputs and Outputs
- ▶ 1.8V Single Power Supply with Optional 3.3V LVTTTL I/O
- ▶ 1.15 Watt Typical Power
- ▶ -5°C Ambient to 90°C Case Temperature
- ▶ 17mm x 17mm, 244-Ball, CBGA Package

### APPLICATIONS:

- ▶ XFP Module XFI to Host SERDES Applications
- ▶ 300 Pin MSA Transponder Modules
- ▶ 10GE and Fibre Channel to SFI-4 SERDES Applications
- ▶ SONET/SDH and DWDM Systems

### BENEFITS:

- ▶ Proven XFP Module Inter-operability
- ▶ Low Power, Full Featured CMOS Transceiver
- ▶ Single Chip Mux/Demux Solution: Provides Complete Set of 300 Pin MSA Transponder Functions Including all Loopback and Clocking Modes
- ▶ Robust Asynchronous Operation and High Immunity to Crosstalk
- ▶ Multiple Reference Clock Source and Clean up Schemes

# VSC8479

## 9.95 Gbps to 11.3 Gbps 16-bit Transceiver

### GENERAL DESCRIPTION:



The VSC8479 is a 1:16, 16:1 transceiver with integrated Clock and Data Recovery unit (CDR) and Clock Multiplier Unit (CMU) that provides the most comprehensive solution available in the industry. Continuous frequency of operation spans from 9.953 Gbps to 11.3 Gbps over full temperature range.

Targeted for XFP Host ASIC SERDES, 300 pin module and DWDM line card applications, the VSC8479 provides industry leading optimization of power, performance, programmability, price and feature integration. The 1.15 W total power dissipation enables 300 pin MSA module vendors to provide performance and functionality advantages while dropping the overall power dissipation of their existing modules. The VSC8479 is a perfect choice for XFP motherboards with proven inter-operability with all major XFP module vendors.

The receiver path has a high sensitivity receiver with a programmable VGA and input bandwidth equalization (EQ) to provide stressed input data eye compensation. No external post amplifier is required for most applications. The high-speed output is swing and pre-emphasis programmable to support a variety laser driver and XFI host ASIC applications.

The VSC8479 fully supports all features, functions and clock modes required for 300-pin multi-source agreement (MSA) transponder module full compliance. All loopback modes are supported with multiple line timing clock modes.

A highly flexible reference clock source selection and reference clock clean-up support scheme is provided to minimize external circuitry. A selectable two-wire serial or Serial Peripheral Interface (SPI) provides full micro-controller access to all status and control registers, including software read-back capability of all external control input pins. Any combination of discrete pins and serial register status and control can be employed. A highly flexible PRBS and user defined pattern checker and error count provides system analysis and built-in self-testing.

Robust cross talk immunity enables the VSC8479 to operate the Tx and Rx paths asynchronously to each other while exceeding SONET level jitter generation and jitter tolerance performance. A high-speed output clock can be optionally enabled for higher performance applications. An adjustable loss of signal (LOS) indicator is integrated into the device enabling optical modulation amplitude monitoring.

The power supply scheme provides a high degree of flexibility. The device can operate on a single +1.8V supply with an optional +3.3V I/O supply for 3.3V compliant interfacing. The Tx path and Rx path can be powered down independently. The single chip, small footprint (17 x 17 mm) allows for both cost reduction and board size reduction for price and size aggressive, small form factor module applications. All VSC8479 devices are tested at high-speed to insure the highest performance and quality standards you've come to expect from Vitesse.

### VSC8479 BLOCK DIAGRAM:

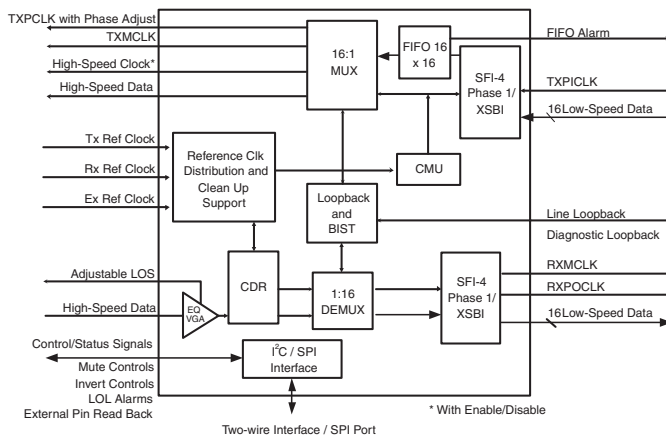

For more information on Vitesse Products visit the Vitesse web site at [www.vitesse.com](http://www.vitesse.com) or contact Vitesse Sales at (800) VITESSE or [sales@vitesse.com](mailto:sales@vitesse.com)

©2004 Vitesse Semiconductor Corporation

Vitesse, ASIC-Friendly, FibreTimer, TimeStream and Snoop Loop are trademarks of Vitesse Semiconductor Corporation. All other trademarks or registered trademarks mentioned herein are the property of their respective holders. Vitesse Semiconductor Corporation ("Vitesse") retains the right to make changes to its products or specifications to improve performance, reliability or manufacturability. All information in this document, including descriptions of features, functions, performance, technical specifications and availability, is subject to change without notice at any time.

## VITESSE

741 Calle Plano  
Camarillo, CA 93012, USA  
Tel: +1 805.388.3700  
Fax: +1 805.987.5896  
[www.vitesse.com](http://www.vitesse.com)

Компания «Life Electronics» занимается поставками электронных компонентов импортного и отечественного производства от производителей и со складов крупных дистрибьюторов Европы, Америки и Азии.

С конца 2013 года компания активно расширяет линейку поставок компонентов по направлению коаксиальный кабель, кварцевые генераторы и конденсаторы (керамические, пленочные, электролитические), за счёт заключения дистрибьюторских договоров

Мы предлагаем:

- Конкурентоспособные цены и скидки постоянным клиентам.
- Специальные условия для постоянных клиентов.
- Подбор аналогов.
- Поставку компонентов в любых объемах, удовлетворяющих вашим потребностям.
- Приемлемые сроки поставки, возможна ускоренная поставка.
- Доставку товара в любую точку России и стран СНГ.
- Комплексную поставку.
- Работу по проектам и поставку образцов.
- Формирование склада под заказчика.
- Сертификаты соответствия на поставляемую продукцию (по желанию клиента).
- Тестирование поставляемой продукции.
- Поставку компонентов, требующих военную и космическую приемку.
- Входной контроль качества.
- Наличие сертификата ISO.

В составе нашей компании организован Конструкторский отдел, призванный помогать разработчикам, и инженерам.

Конструкторский отдел помогает осуществить:

- Регистрацию проекта у производителя компонентов.
- Техническую поддержку проекта.
- Защиту от снятия компонента с производства.
- Оценку стоимости проекта по компонентам.
- Изготовление тестовой платы монтаж и пусконаладочные работы.



Тел: +7 (812) 336 43 04 (многоканальный)

Email: [org@lifeelectronics.ru](mailto:org@lifeelectronics.ru)