

DATA SHEET

SKY66110-11: Low-Power Bluetooth® Low Energy Front-End Module for Range Extension Applications

Applications

- Range extender
- Wearable technology
- Beacons
- Sensors
- Home automation
- Internet of Things (IoT) devices

Features

- Low power consumption: 10 mA @ +10 dBm
- Output: +10 dBm
- Supply operation: 1.8 to 5 V
- Low sleep current: < 1 μ A
- RX bypass
- Small MCM (20-pin, 3.3 x 3.0 x 0.8 mm) package (MSL3, 260 °C per JEDEC-J-STD-020)



Skyworks Green™ products are compliant with all applicable legislation and are halogen-free. For additional information, refer to *Skyworks Definition of Green™*, document number SQ04-0074.

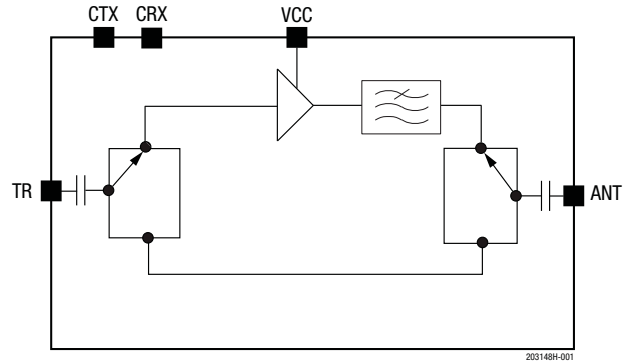

Figure 1. SKY66110-11 Functional Block Diagram

Description

The SKY66110-11 is a highly integrated front-end module (FEM) designed for Bluetooth Low Energy (BLE) range extension applications operating in the 2.4 to 2.485 GHz range.

The device is provided in a 3.3 x 3.0 x 0.8 mm MCM package. A functional block diagram is shown in Figure 1. Pin assignments are shown in Figure 2. Signal pin assignments and functional pin descriptions are provided in Table 1.

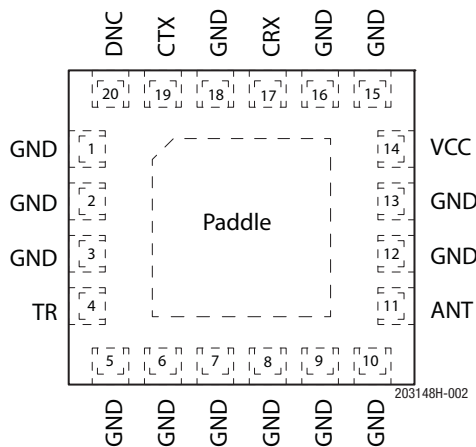

Figure 2. SKY66110-11 Pinout (Top View)

Table 1. SKY66110-11 Signal Descriptions¹

Pin	Name	Description	Pin	Name	Description
1	GND	Ground	11	ANT	Antenna port
2	GND	Ground	12	GND	Ground
3	GND	Ground	13	GND	Ground
4	TR	Common receive/transmit port	14	VCC	Positive power supply
5	GND	Ground	15	GND	Ground
6	GND	Ground	16	GND	Ground
7	GND	Ground	17	CRX	RX control signal
8	GND	Ground	18	GND	Ground
9	GND	Ground	19	CTX	Tx control signal and amplifier bias voltage
10	GND	Ground	20	DNC	Do not connect

¹ The paddle should be connected to ground. See Figure 6.

Electrical and Mechanical Specifications

The absolute maximum ratings of the SKY66110-11 are provided in Table 2. The recommended operating conditions are specified in Table 3.

Electrical specifications are provided in Tables 4 through 8.

Table 2. SKY66110-11 Absolute Maximum Ratings¹

Parameter	Symbol	Minimum	Maximum	Units
Supply voltage	VCC		5.5	V
Control voltages	VCTX, VCRX		5.0	V
RF Input power	PIN		+20	dBm
Voltage standing wave ratio	VSWR		10:1	
Operating temperature	TA	-40	+85	°C
Storage temperature	TSTG	-65	+150	°C
Electrostatic discharge: Human Body Model (HBM), Class 0	ESD		150	V

¹ Exposure to maximum rating conditions for extended periods may reduce device reliability. There is no damage to device with only one parameter set at the limit and all other parameters set at or below their nominal value. Exceeding any of the limits listed here may result in permanent damage to the device.

ESD HANDLING: *Although this device is designed to be as robust as possible, electrostatic discharge (ESD) can damage this device. This device must be protected at all times from ESD when handling or transporting. Static charges may easily produce potentials of several kilovolts on the human body or equipment, which can discharge without detection. Industry-standard ESD handling precautions should be used at all times.*

Table 3. Recommended Operating Conditions

Parameter	Symbol	Min	Typ	Max	Units
Frequency	f	2.4		2.485	GHz
Supply voltage	VCC	1.8	3	5.0	V
Control voltages	VCTX, VCRX	1.7	3	VCC	V
Operating temperature	TA		25		°C

Table 4. SKY66110-11 Electrical Specifications: DC Characteristics¹
(V_{CC} = 3.3 V, V_{CTX} = 1.8 V, T_A = +25 °C, R_S = 0 kΩ, Characteristic Impedance [Z₀] = 50 Ω, Unless Otherwise Noted)

Parameter	Symbol	Test Condition	Min	Typ	Max	Units
RX current (bypass)	I _{CQ_RX}	RX mode		1		μA
TX quiescent current ²	I _{CQ_TX}	TX mode		6		mA
TX operating current ²	I _{OP_TX}	TX mode (P _{IN} = -1 dBm): V _{CC} = 1.8 V V _{CC} = 3.0 V V _{CC} = 3.3 V V _{CC} = 5.0 V		8.5 10 10.5 11		mA mA mA mA
TX bias current (CTX pin)	I _{BIAS_TX}			550		μA
Sleep current ³	I _{CC_OFF}	Sleep mode		0.1	1	μA

¹ Performance is guaranteed only under the conditions listed in this table.

² For total current, I_{BIAS_TX} should be added to the values.

³ V_{CTX} = 0 V.

Table 5. SKY66110-11 Electrical Specifications Transmit Characteristics¹
(V_{CC} = 3.3 V, V_{CTX} = 1.8 V, T_A = +25 °C, P_{IN} = -1 dBm, R_S = 0 kΩ, Characteristic Impedance [Z₀] = 50 Ω, Unless Otherwise Noted)

Parameter	Symbol	Test Condition	Min	Typ	Max	Units
Output power	P _{OUT}	V _{CC} = 1.8 V V _{CC} = 3.0 V V _{CC} = 3.3 V V _{CC} = 5.0 V		+8 +10 +10.3 +10.8		dBm dBm dBm dBm
Saturated gain ²	G _{SAT}	P _{IN} = -1 dBm		11		dB
Gain slope	G _{SLOPE}	Over frequency range		0.7	1	dB
Input return loss	S ₁₁			-14		dB
Output return loss	S ₂₂			-10		dB
Insertion loss (sleep mode) ²	S _{21_SLEEP}			-15	-12	dB
Third order input intercept point ²	IIP ₃	@ 2.44 GHz, Δf = ± 1 MHz, P _{IN} = -14 dBm/tone		+5		dBm
Third order output intercept point ²	OIP ₃	@ 2.44 GHz, Δf = ± 1 MHz, P _{IN} = -14 dBm/tone		+16		dBm
1 dB input compression point	IP1dB			-1		dBm
1 dB output compression point	OP1dB			+10		dBm
2 nd to 10 th harmonics ²	2fo to 10fo				-30	dBm/MHz
RX to TX transition time ²	t _{SWITCH}	10% to 90% RF 50% V _{CTX} to 90% RF		500		ns
TX power on time ²	t _{ON}	10% to 90% RF 50% V _{CTX} to 90% RF		500		ns
TX power off time ²	t _{OFF}	90% to 10% RF 50% V _{CTX} to 10% RF		150		ns

¹ Performance is guaranteed only under the conditions listed in this table.

² Guaranteed by characterization.

Table 6. SKY66110-11 Electrical Specifications: Receive Characteristics¹
(V_{CC} = 3.3 V, V_{CRX} = 1.8 V, V_{CTX} = 0 V, T_A = +25 °C, P_{IN} = -20 dBm, Characteristic Impedance [Z₀] = 50 Ω, Unless Otherwise Noted)

Parameter	Symbol	Test Condition	Min	Typ	Max	Units
Insertion loss	S21			0.9		dB
Isolation	S12	TX Mode (P _{IN} = -20 dBm)		25		dB
Input return loss	S11			-15		dB
Output return loss	S22			-15		dB
TX to RX transition time ²	t _{SWITCH}	10% to 90% RF 50% V _{CRX} to 90% RF		500		ns
RX power on time ²	t _{ON}	10% to 90% RF 50% V _{CRX} to 90% RF		150		ns
RX power off time ²	t _{OFF}	90% to 10% RF 50% V _{CRX} to 10% RF		150		ns

¹ Performance is guaranteed only under the conditions listed in this table.

² Guaranteed by characterization.

Table 7. SKY66110-11 Electrical Characteristics: Logic Characteristics (T_A = +25 °C)

Parameter	Symbol	Minimum	Maximum	Units
Voltage logic high ¹	V _{HIGH}	1.8	5	V
Voltage logic low	V _{LOW}	0	0.2	V

¹ Difference between logic high voltages for V_{CRX} and V_{CTX} should not exceed 0.2 V.

Table 8. SKY66110-11 Mode Logic Truth Table

Mode	CTX	CRX
Sleep mode	0	0
Receive (RX) mode	0	1
Transmit (TX) mode	1	0
Non-permissible state ¹	1	1

¹ This state will enable both the TX and RX paths. It is not permitted to operate in this state.

Evaluation Board Description

The SKY66110-11 Evaluation Board is used to test the performance of the SKY66110-11 front-end module. The board is optimized for evaluation, experimentation, and investigation with an 802.15.4 signal source. The design and layout can be quickly and easily transferred into a production design.

An Evaluation Board schematic diagram is provided in Figure 3. A reference design schematic is provided in Figure 4. Table 9 provides the Bill of Materials (BOM) list for Evaluation Board components. A photograph of the Evaluation Board is shown in Figure 5.

Evaluation Board Setup Procedure

Connect Supply

1. Connect J1 and J4 to 50 Ω instruments. Terminate all unused ports (if applicable) with 50 Ω .
2. Connect the supply ground to Pins 1, 4, and 6 of J2.
3. Connect 3.3 V to pin 7 of J2.
4. Connect 1.8 V to one of the logic pins (pin 3 or pin 5) on J2 to select RX or TX mode. Connect the other logic pin to ground. Refer to Table 8 for mode control settings.

Measure Performance

TX

Monitor the 2.4 GHz amplifier performance by applying an RF signal to connector J4 (TR) and verify the output power on connector J1 (ANT).

RX

Monitor the 2.4 GHz switch performance by applying an RF signal to connector J1 (ANT) and verify the output signal on connector J4 (TR).

CAUTION: Be careful not to overdrive the switch by applying too much RF on the input to the device. A starting input power of -20 dBm is suitable.

Package Dimensions

The PCB layout footprint for the SKY66110-11 is provided in Figure 6. Typical part markings are shown in Figure 7. Package dimensions are shown in Figure 8, and tape and reel dimensions are provided in Figure 9.

Package and Handling Information

Since the device package is sensitive to moisture absorption, it is baked and vacuum packed before shipping. Instructions on the shipping container label regarding exposure to moisture after the container seal is broken must be followed. Otherwise, problems related to moisture absorption may occur when the part is subjected to high temperature during solder assembly.

The SKY66110-11 is rated to Moisture Sensitivity Level 3 (MSL3) at 260 °C. It can be used for lead or lead-free soldering. For additional information, refer to the Skyworks Application Note, *PCB Design and SMT Assembly/Rework Guidelines for MCM-L Packages*, document number 101752.

Care must be taken when attaching this product, whether it is done manually or in a production solder reflow environment. Production quantities of this product are shipped in a standard tape and reel format.

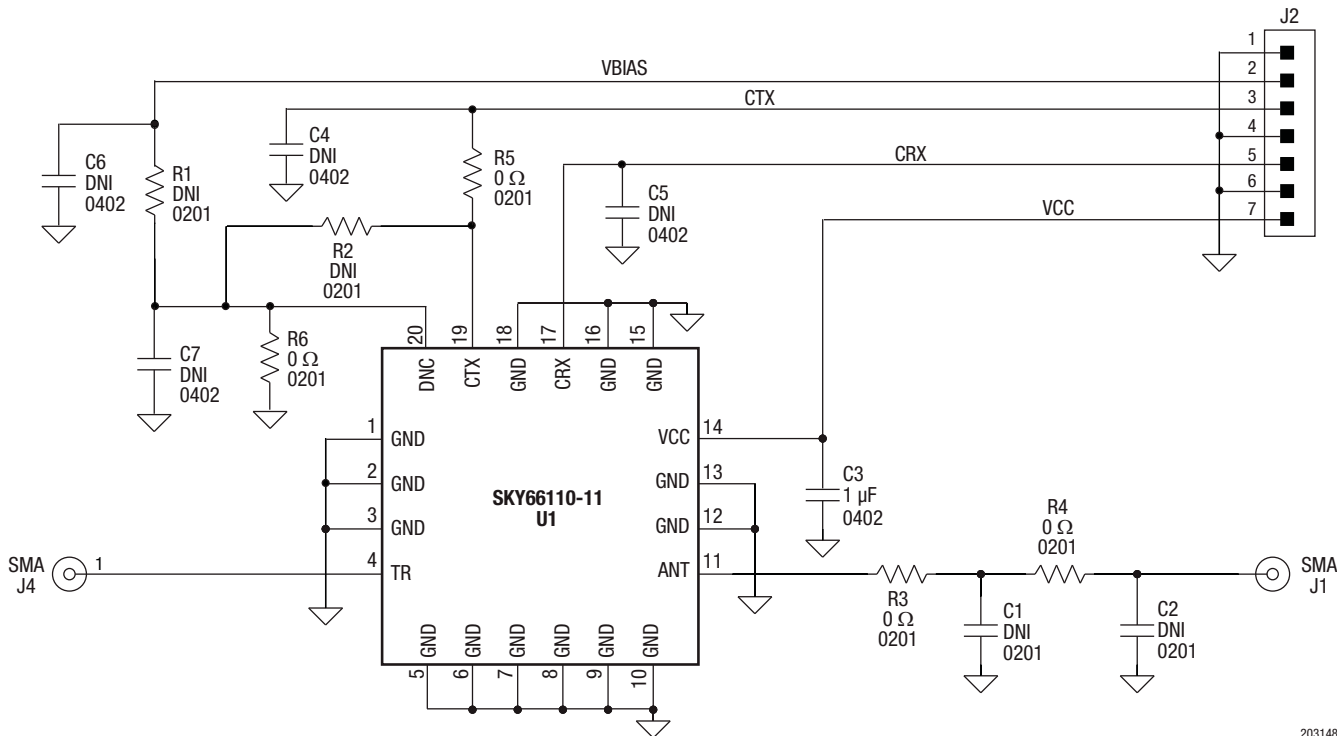

203148H-003

Figure 3. SKY66110-11 Evaluation Board Schematic

Note: Include a footprint for R2 to enable compatibility with both the SKY66110-11 and the SKY66111-11

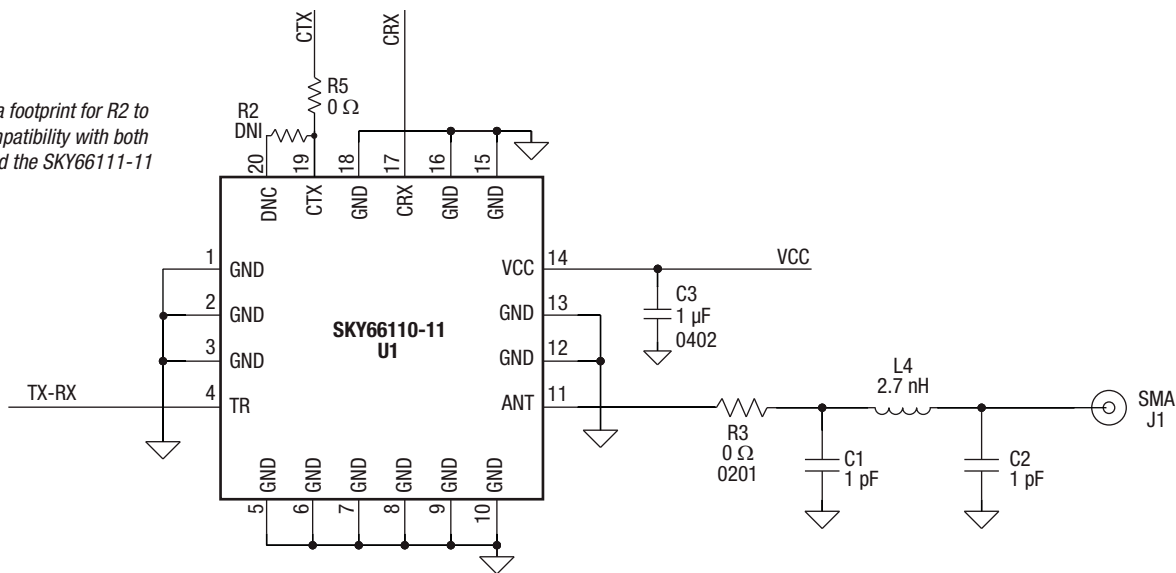

203184H-004

Figure 4. SKY66110-11 Reference Design Schematic

Table 9. SKY66110-11 Evaluation Board Bill of Materials (BOM)

Component	Value	Size	Manufacturer	Mfr Part Number	Characteristics
C1, C2	DNI	0201			
C3	1 uF	0402			Capacitor
C4, C5, C6	DNI	0402			
J1, J4	SMA	end launch	Johnson Components	142-0701-851	SMA end launch straight jack receptacle - tab contact
J2	7X1	100 mil	Samtec	TSW-107-07-G-S	100mil header
PCB1	Z720-B		Skyworks Solutions Inc.	Z720-B	PCB
R1, R2	DNI	0201			Do not install
R3, R4, R5, R6	0 Ω	0201	Panasonic	ERJ1GE0R00	Thick film chip resistor
U1	SKY66110-11	MCM50P300X330-20	Skyworks Solutions Inc.	SKY66110-11	Low-power Bluetooth low energy FEM

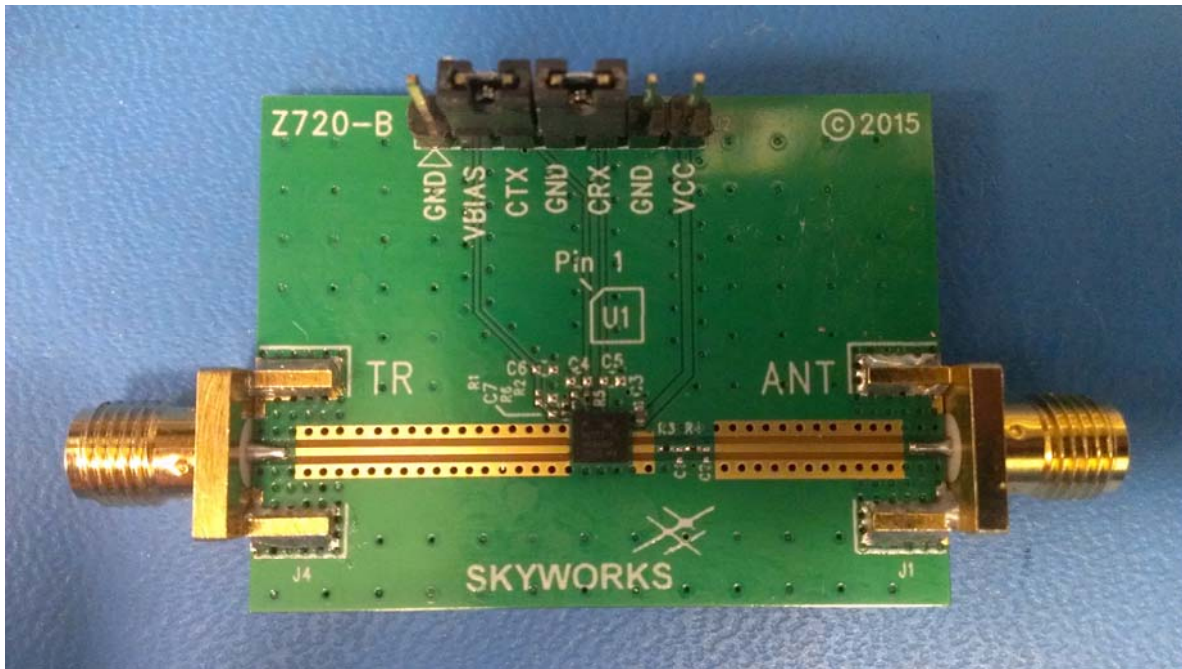
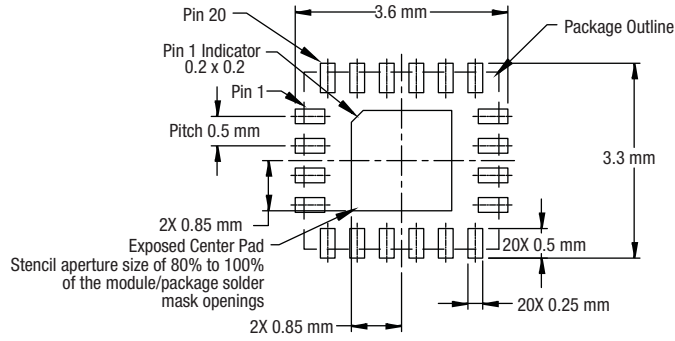
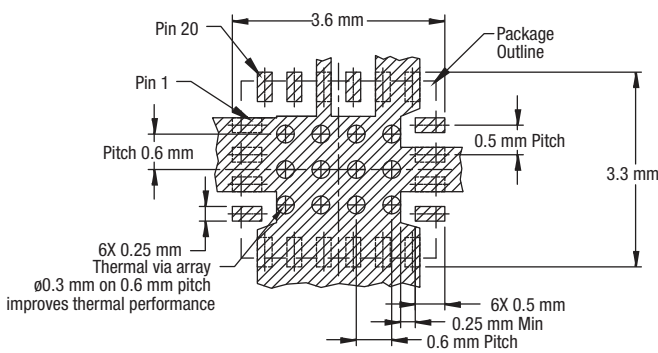

Figure 5. SKY66110-11 Evaluation Board



Stencil Aperture



Metallization

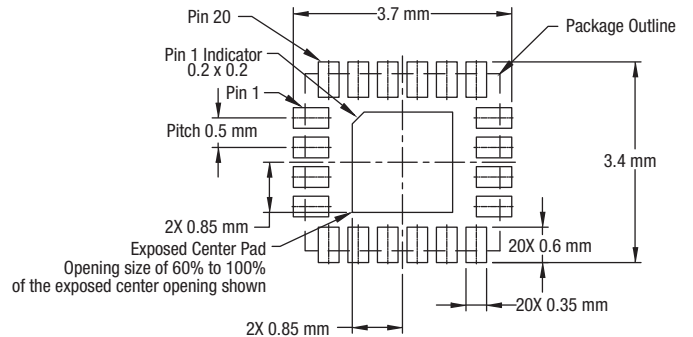

Solder Mask Opening

Notes:

1. All dimensions are in millimeters, unless otherwise specified.
2. Thermal vias should be resin filled and capped in accordance with IPC-4761 Type VII vias. Recommended Cu thickness is 30 to 35 μ m.

203184H-006

Figure 6. PCB Layout Footprint

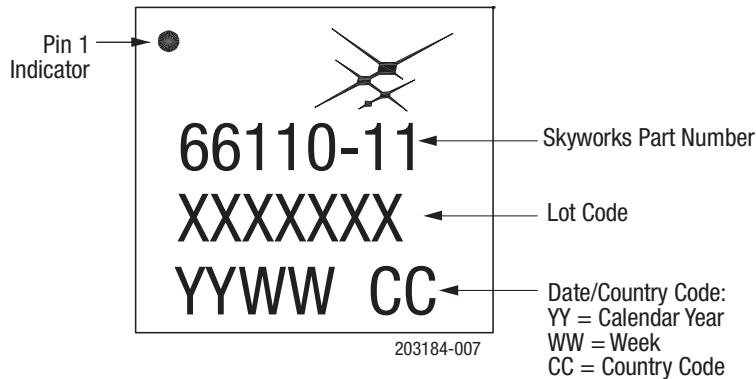

Figure 7. Typical Part Marking

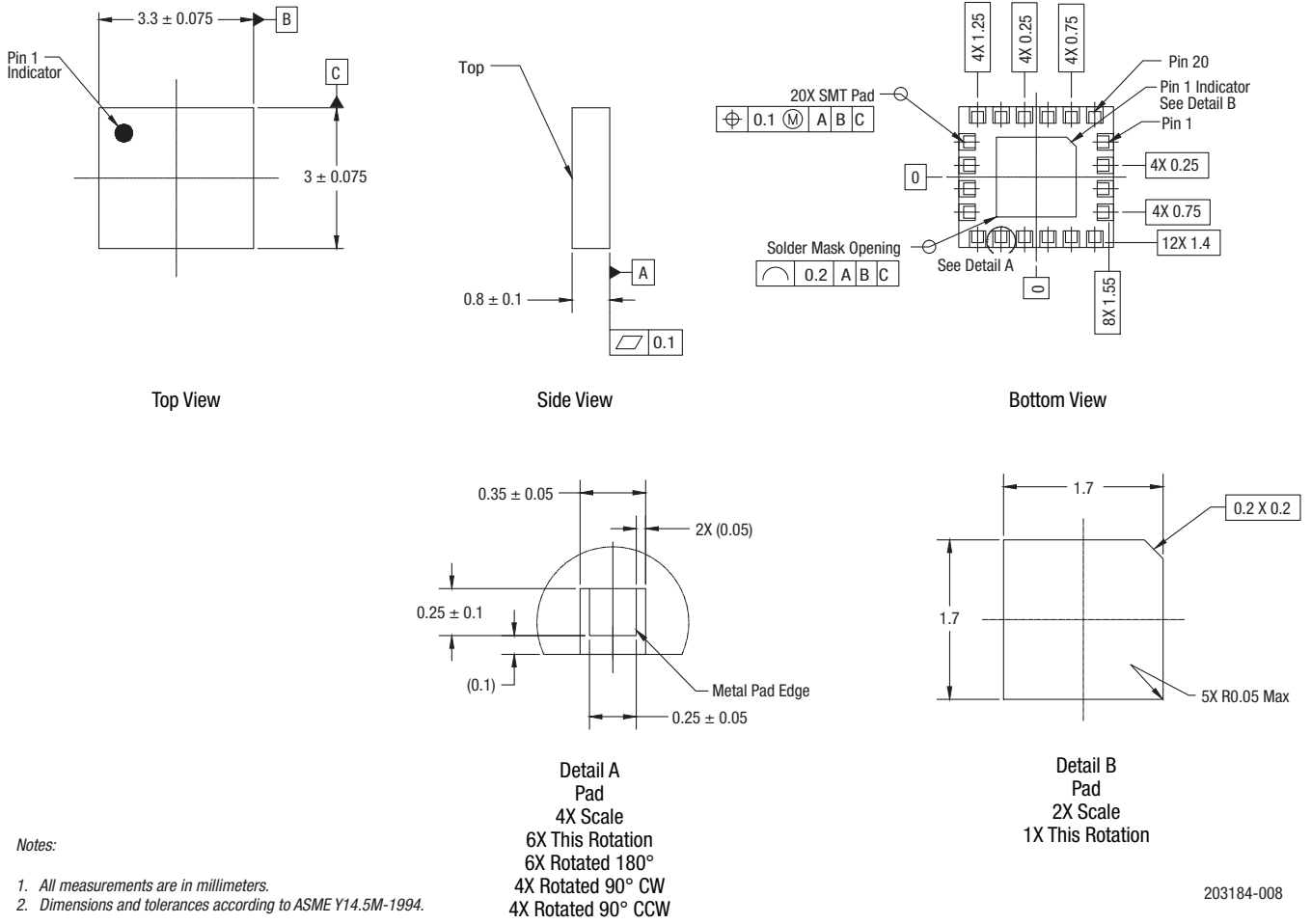

Figure 8. SKY66110 Package Dimensions

DATA SHEET • SKY66110-11: LOW-POWER BLUETOOTH LOW ENERGY FEM

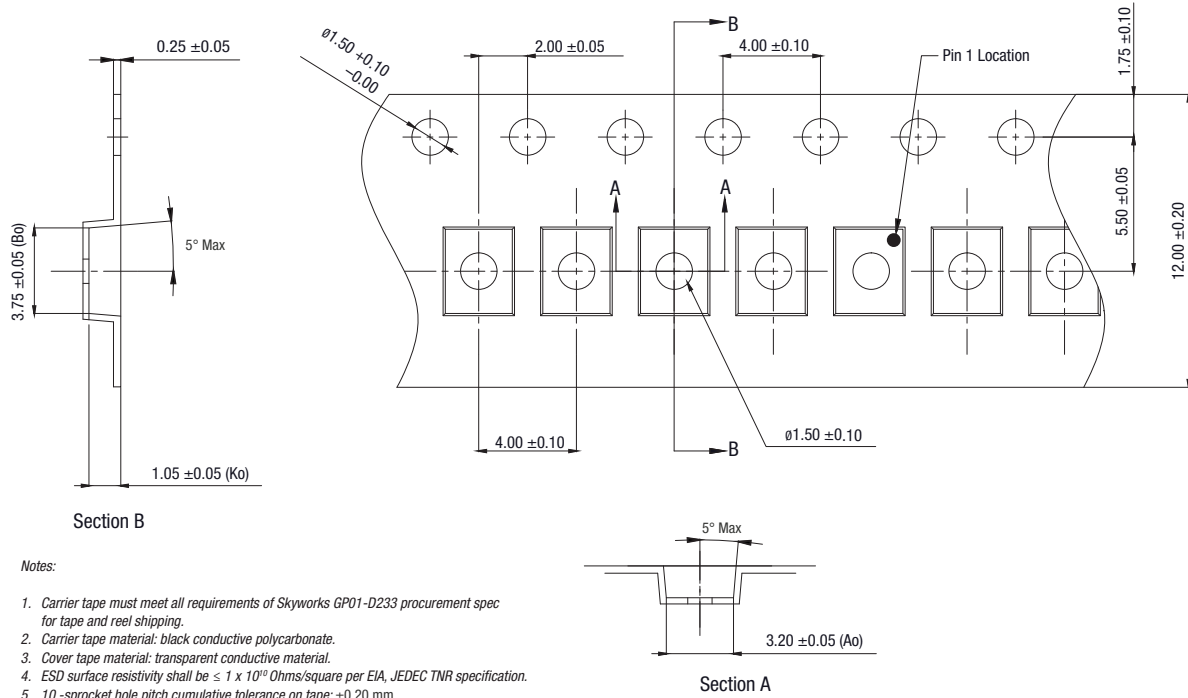

Figure 9. SKY66110-11 Tape and Reel Dimensions

Ordering Information

Part Number	Product Description	Evaluation Board Part Number
SKY66110-11	Low-Power Bluetooth Low Energy FEM	SKY66110-11-EK1

Copyright © 2014-2016, 2018 Skyworks Solutions, Inc. All Rights Reserved.

Information in this document is provided in connection with Skyworks Solutions, Inc. ("Skyworks") products or services. These materials, including the information contained herein, are provided by Skyworks as a service to its customers and may be used for informational purposes only by the customer. Skyworks assumes no responsibility for errors or omissions in these materials or the information contained herein. Skyworks may change its documentation, products, services, specifications or product descriptions at any time, without notice. Skyworks makes no commitment to update the materials or information and shall have no responsibility whatsoever for conflicts, incompatibilities, or other difficulties arising from any future changes.

No license, whether express, implied, by estoppel or otherwise, is granted to any intellectual property rights by this document. Skyworks assumes no liability for any materials, products or information provided hereunder, including the sale, distribution, reproduction or use of Skyworks products, information or materials, except as may be provided in Skyworks Terms and Conditions of Sale.

THE MATERIALS, PRODUCTS AND INFORMATION ARE PROVIDED "AS IS" WITHOUT WARRANTY OF ANY KIND, WHETHER EXPRESS, IMPLIED, STATUTORY, OR OTHERWISE, INCLUDING FITNESS FOR A PARTICULAR PURPOSE OR USE, MERCHANTABILITY, PERFORMANCE, QUALITY OR NON-INFRINGEMENT OF ANY INTELLECTUAL PROPERTY RIGHT; ALL SUCH WARRANTIES ARE HEREBY EXPRESSLY DISCLAIMED. SKYWORKS DOES NOT WARRANT THE ACCURACY OR COMPLETENESS OF THE INFORMATION, TEXT, GRAPHICS OR OTHER ITEMS CONTAINED WITHIN THESE MATERIALS. SKYWORKS SHALL NOT BE LIABLE FOR ANY DAMAGES, INCLUDING BUT NOT LIMITED TO ANY SPECIAL, INDIRECT, INCIDENTAL, STATUTORY, OR CONSEQUENTIAL DAMAGES, INCLUDING WITHOUT LIMITATION, LOST REVENUES OR LOST PROFITS THAT MAY RESULT FROM THE USE OF THE MATERIALS OR INFORMATION, WHETHER OR NOT THE RECIPIENT OF MATERIALS HAS BEEN ADVISED OF THE POSSIBILITY OF SUCH DAMAGE.

Skyworks products are not intended for use in medical, lifesaving or life-sustaining applications, or other equipment in which the failure of the Skyworks products could lead to personal injury, death, physical or environmental damage. Skyworks customers using or selling Skyworks products for use in such applications do so at their own risk and agree to fully indemnify Skyworks for any damages resulting from such improper use or sale.

Customers are responsible for their products and applications using Skyworks products, which may deviate from published specifications as a result of design defects, errors, or operation of products outside of published parameters or design specifications. Customers should include design and operating safeguards to minimize these and other risks. Skyworks assumes no liability for applications assistance, customer product design, or damage to any equipment resulting from the use of Skyworks products outside of stated published specifications or parameters.

Skyworks and the Skyworks symbol are trademarks or registered trademarks of Skyworks Solutions, Inc. or its subsidiaries in the United States and other countries. Third-party brands and names are for identification purposes only, and are the property of their respective owners. Additional information, including relevant terms and conditions, posted at www.skyworksinc.com, are incorporated by reference.

Компания «Life Electronics» занимается поставками электронных компонентов импортного и отечественного производства от производителей и со складов крупных дистрибьюторов Европы, Америки и Азии.

С конца 2013 года компания активно расширяет линейку поставок компонентов по направлению коаксиальный кабель, кварцевые генераторы и конденсаторы (керамические, пленочные, электролитические), за счёт заключения дистрибьюторских договоров

Мы предлагаем:

- Конкуренспособные цены и скидки постоянным клиентам.
- Специальные условия для постоянных клиентов.
- Подбор аналогов.
- Поставку компонентов в любых объемах, удовлетворяющих вашим потребностям.
- Приемлемые сроки поставки, возможна ускоренная поставка.
- Доставку товара в любую точку России и стран СНГ.
- Комплексную поставку.
- Работу по проектам и поставку образцов.
- Формирование склада под заказчика.
- Сертификаты соответствия на поставляемую продукцию (по желанию клиента).
- Тестирование поставляемой продукции.
- Поставку компонентов, требующих военную и космическую приемку.
- Входной контроль качества.
- Наличие сертификата ISO.

В составе нашей компании организован Конструкторский отдел, призванный помогать разработчикам, и инженерам.

Конструкторский отдел помогает осуществить:

- Регистрацию проекта у производителя компонентов.
- Техническую поддержку проекта.
- Защиту от снятия компонента с производства.
- Оценку стоимости проекта по компонентам.
- Изготовление тестовой платы монтаж и пусконаладочные работы.



Тел: +7 (812) 336 43 04 (многоканальный)

Email: org@lifeelectronics.ru