

N-channel 400 V, 0.85 Ω typ., 5.4 A, SuperMESH™ Power MOSFETs in DPAK, TO-220 and TO-220FP packages

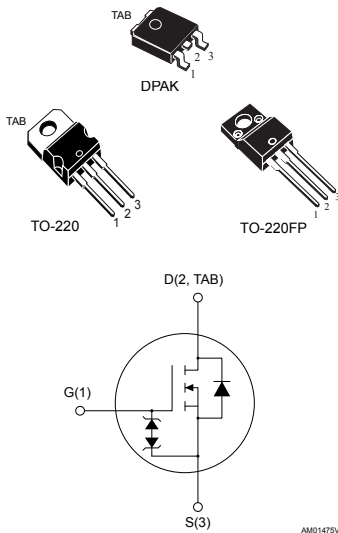

Features

Order code	V_{DS}	$R_{DS(on)}$ max.	I_D	P_{TOT}
STD7NK40ZT4	400 V	1 Ω	5.4 A	70 W
STP7NK40Z				70 W
STP7NK40ZFP				25 W

- Extremely high dv/dt capability
- 100% avalanche tested
- Gate charge minimized
- Very low intrinsic capacitance
- Zener-protected

Applications

- Switching applications

Description

These high-voltage devices are Zener-protected N-channel Power MOSFETs developed using the SuperMESH™ technology by STMicroelectronics, an optimization of the well-established PowerMESH™. In addition to a significant reduction in on-resistance, these devices are designed to ensure a high level of dv/dt capability for the most demanding applications.

Product status links

[STD7NK40ZT4](#)
[STP7NK40Z](#)
[STP7NK40ZFP](#)

Product summary

STD7NK40ZT4

Marking	D7NK40Z
Package	DPAK
Packing	Tape and reel

STP7NK40Z

Marking	P7NK40Z
Package	TO-220
Packing	Tube

STP7NK40ZFP

Marking	P7NK40ZFP
Package	TO-220FP
Packing	Tube

1 Electrical ratings

Table 1. Absolute maximum ratings

Symbol	Parameter	Value			Unit
		STD7NK40ZT4	STP7NK40Z	STP7NK40ZFP	
V _{DS}	Drain-source voltage	400			V
V _{DGR}	Drain-gate voltage (R _{GS} = 20 kΩ)	400			V
V _{GS}	Gate-source voltage	±30			V
I _D	Drain current (continuous) at T _C = 25 °C	5.4	5.4	5.4 ⁽¹⁾	A
	Drain current (continuous) at T _C = 100 °C	3.4	3.4	3.4 ⁽¹⁾	A
I _{DM} ⁽²⁾	Drain current (pulsed)	21.6	21.6	21.6 ⁽¹⁾	A
P _{TOT}	Total dissipation at T _C = 25 °C	70	70	25	W
I _{AR}	Avalanche current, repetitive or non-repetitive (pulse width is limited by T _J max.)	5.4			A
E _{AS}	Single pulse avalanche energy (starting T _J = 25 °C, I _D = I _{AR} , V _{DD} = 50 V)	130			mJ
ESD	Gate-source, human body model, R = 1.5 kΩ, C = 100 pF	3			kV
dv/dt ⁽³⁾	Peak diode recovery voltage slope	4.5			V/ns
V _{ISO}	Insulation withstand voltage (RMS) from all three leads to external heat sink (t = 1 s, T _C = 25 °C)			2.5	kV
T _J	Operating junction temperature range	-55 to 150			°C
T _{stg}	Storage temperature range				

1. This value is limited by maximum junction temperature.

2. Pulse width is limited by safe operating area.

3. I_{SD} ≤ 5.4 A, di/dt ≤ 200 A/μs, V_{DD} < V_{(BR)DSS}

Table 2. Thermal data

Symbol	Parameter	Value			Unit
		DPAK	TO-220	TO-220FP	
R _{thj-case}	Thermal resistance junction-case	1.78	1.78	5	°C/W
R _{thj-amb}	Thermal resistance junction-ambient			62.5	°C/W
R _{thj-pcb} ⁽¹⁾	Thermal resistance junction-pcb	50			°C/W

1. When mounted on an 1-inch² FR-4, 2 Oz copper board.

2 Electrical characteristics

($T_C = 25\text{ }^\circ\text{C}$ unless otherwise specified)

Table 3. On/off states

Symbol	Parameter	Test conditions	Min.	Typ.	Max.	Unit
$V_{(BR)DSS}$	Drain-source breakdown voltage	$I_D = 1\text{ mA}$, $V_{GS} = 0\text{ V}$	400			V
I_{DSS}	Zero gate voltage drain current	$V_{GS} = 0\text{ V}$, $V_{DS} = 400\text{ V}$			1	μA
		$V_{GS} = 0\text{ V}$, $V_{DS} = 400\text{ V}$, $T_C = 125\text{ }^\circ\text{C}^{(1)}$			50	μA
I_{GSS}	Gate body leakage current	$V_{GS} = \pm 20\text{ V}$, $V_{DS} = 0\text{ V}$			± 10	μA
$V_{GS(th)}$	Gate threshold voltage	$V_{DS} = V_{GS}$, $I_D = 50\text{ }\mu\text{A}$	3	3.75	4.5	V
$R_{DS(on)}$	Static drain-source on-resistance	$V_{GS} = 10\text{ V}$, $I_D = 2.7\text{ A}$		0.85	1	Ω

1. Defined by design, not subject to production test.

Table 4. Dynamic

Symbol	Parameter	Test conditions	Min.	Typ.	Max.	Unit
C_{iss}	Input capacitance	$V_{DS} = 25\text{ V}$, $f = 1\text{ MHz}$, $V_{GS} = 0\text{ V}$	-	535	-	μF
C_{oss}	Output capacitance			82		
C_{rss}	Reverse transfer capacitance			18		
$C_{oss\text{ eq.}}^{(1)}$	Equivalent output capacitance	$V_{GS} = 0\text{ V}$, $V_{DS} = 0\text{ to }320\text{ V}$	-	53	-	μF
Q_g	Total gate charge	$V_{DD} = 320\text{ V}$, $I_D = 5.4\text{ A}$, $V_{GS} = 0\text{ to }10\text{ V}$ (see Figure 16. Test circuit for gate charge behavior)	-	19	26	nC
Q_{gs}	Gate-source charge			4		
Q_{gd}	Gate-drain charge			10		

1. $C_{oss\text{ eq.}}$ is defined as the constant equivalent capacitance giving the same charging time as C_{oss} when V_{DS} increases from 0 to 80% V_{DSS} .

Table 5. Switching times

Symbol	Parameter	Test conditions	Min.	Typ.	Max.	Unit
$t_{d(on)}$	Turn-on delay time	$V_{DD} = 200\text{ V}$, $I_D = 2.7\text{ A}$, $R_G = 4.7\text{ }\Omega$, $V_{GS} = 10\text{ V}$	-	15	-	ns
t_r	Rise time			15		
$t_{d(off)}$	Turn-off delay time	(see Figure 15. Test circuit for resistive load switching times and Figure 20. Switching time waveform)	-	30	-	ns
t_f	Fall time			12		
$t_{r(Voff)}$	Off-voltage rise time	$V_{DD} = 320\text{ V}$, $I_D = 5.4\text{ A}$, $R_G = 4.7\text{ }\Omega$, $V_{GS} = 10\text{ V}$	-	12	-	ns
t_f	Fall time			10		
t_c	Crossover time	(see Figure 17. Test circuit for inductive load switching and diode recovery times)	-	20	-	ns

Table 6. Source-drain diode

Symbol	Parameter	Test conditions	Min.	Typ.	Max.	Unit
I_{SD}	Source-drain current		-		5.4	A
$I_{SDM}^{(1)}$	Source-drain current (pulsed)				21.6	
$V_{SD}^{(2)}$	Forward on voltage	$I_{SD} = 5.4 \text{ A}$, $V_{GS} = 0 \text{ V}$	-		1.6	V
t_{rr}	Reverse recovery time	$I_{SD} = 5.4 \text{ A}$, $di/dt = 100 \text{ A}/\mu\text{s}$, $V_{DD} = 50 \text{ V}$, $T_J = 150 \text{ }^\circ\text{C}$ (see Figure 17. Test circuit for inductive load switching and diode recovery times)	-	220		ns
Q_{rr}	Reverse recovery charge			990		nC
I_{RRM}	Reverse recovery current			9		A

1. Pulsed: pulse duration = 300 μs , duty cycle 1.5%.

2. Pulse width is limited by safe operating area.

Table 7. Gate-source Zener diode

Symbol	Parameter	Test conditions	Min.	Typ.	Max.	Unit
$V_{(BR)GSO}$	Gate-source breakdown voltage	$I_{GS} = \pm 1 \text{ mA}$ (open drain)	30	-	-	V

The built-in back-to-back Zener diodes are specifically designed to enhance the ESD performance of the device. The Zener voltage facilitates efficient and cost-effective device integrity protection, thus eliminating the need for additional external componentry.

2.1 Electrical characteristics (curves)

Figure 1. Safe operating area for TO-220/DPAK

Figure 2. Thermal impedance for TO-220/DPAK

Figure 3. Safe operating area for TO-220FP

Figure 4. Thermal impedance for TO-220FP

Figure 5. Output characteristics

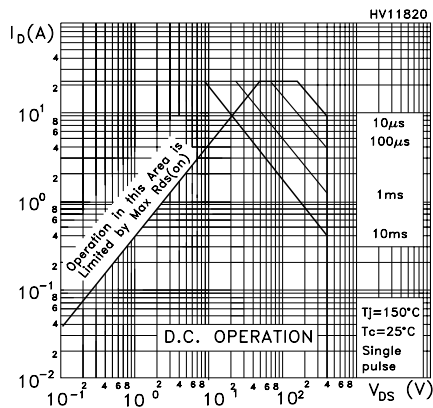
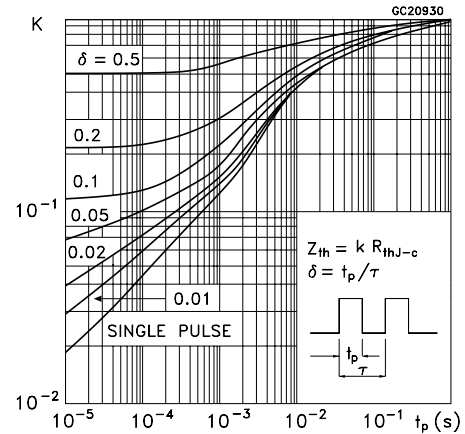
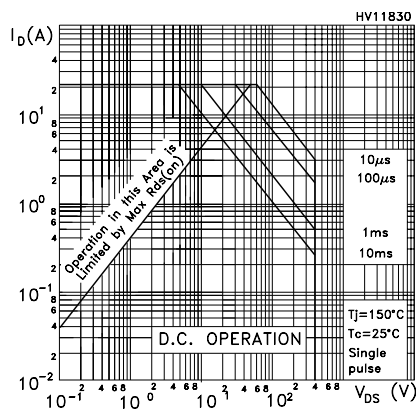
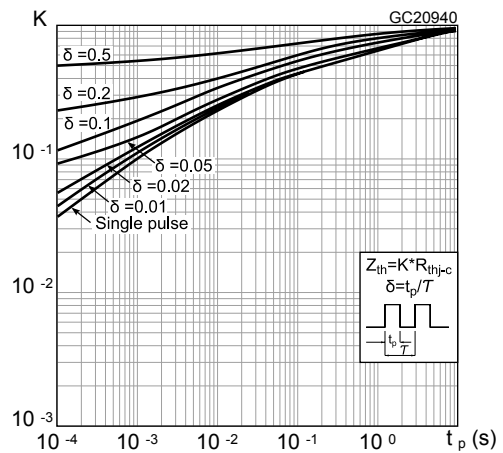
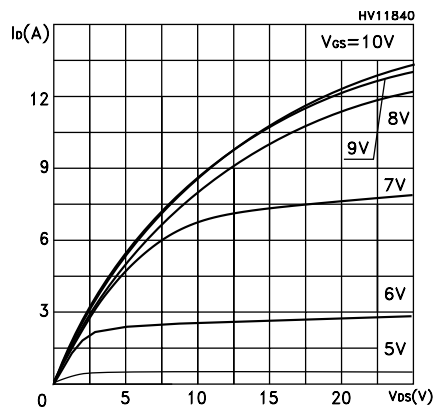
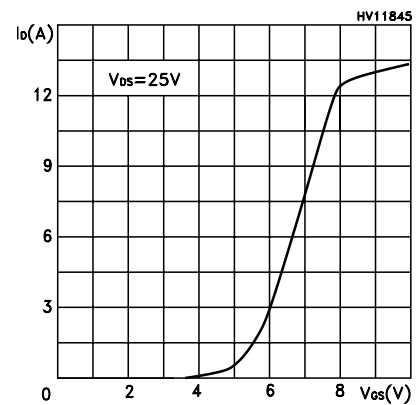
Figure 6. Transfer characteristics

Figure 7. Static drain-source on-resistance

Figure 8. Gate charge vs gate-source voltage

Figure 9. Capacitance variations

Figure 10. Normalized gate threshold voltage vs temperature

Figure 11. Normalized on-resistance vs temperature

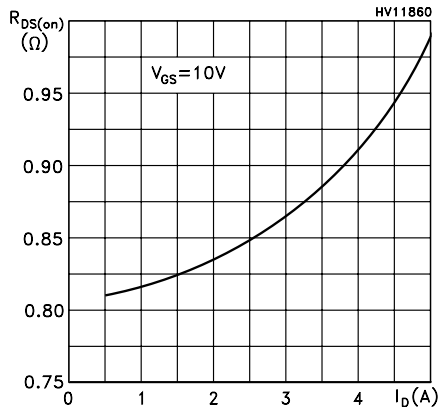
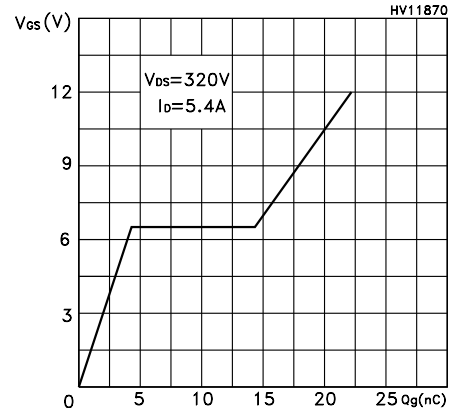
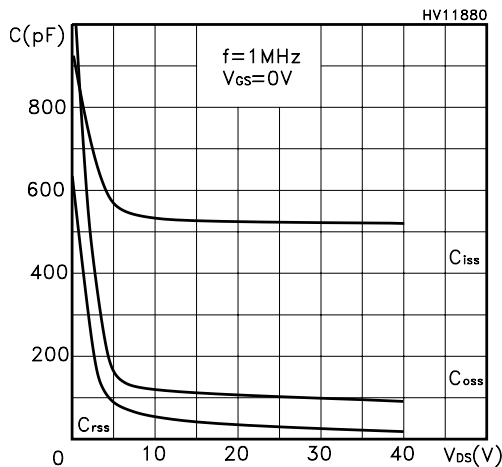
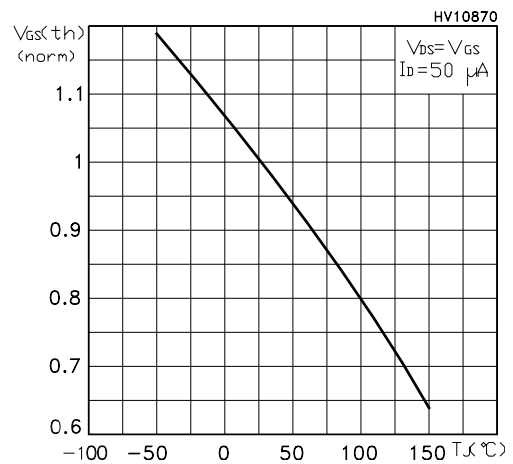
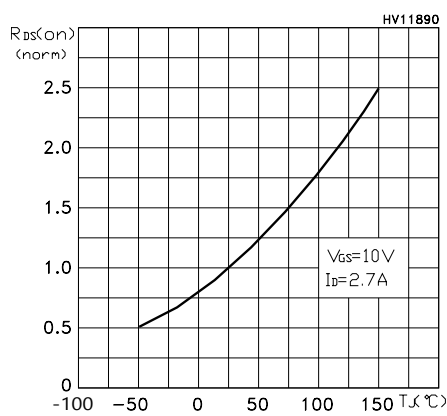
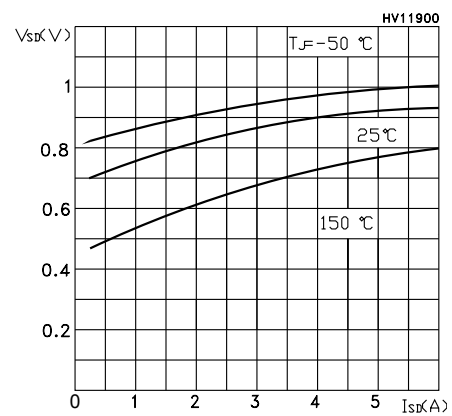
Figure 12. Source-drain diode forward characteristics

Figure 13. Normalized $V_{(BR)DSS}$ vs temperature

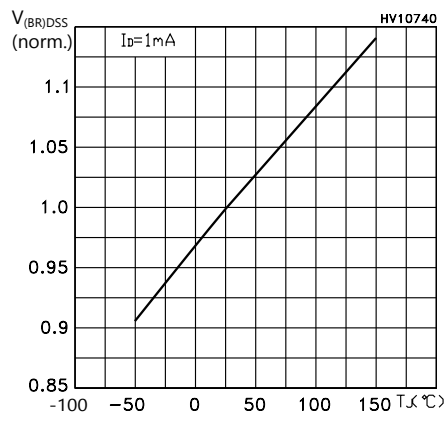
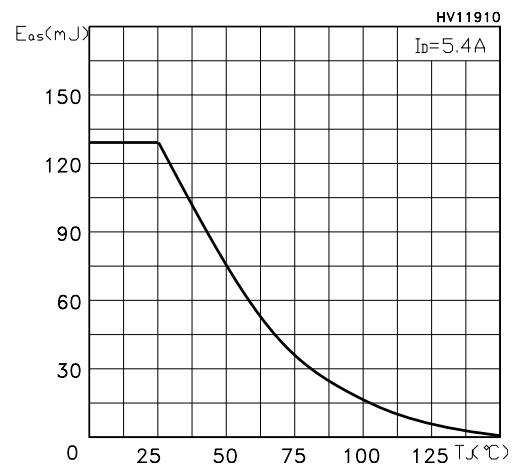
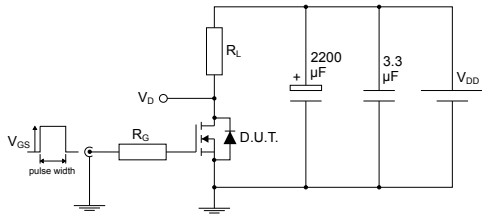

Figure 14. Maximum avalanche energy vs temperature



3 Test circuits

Figure 15. Test circuit for resistive load switching times

AM01468v1

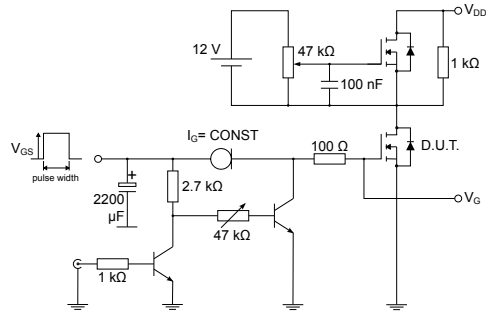
Figure 16. Test circuit for gate charge behavior

AM01469v1

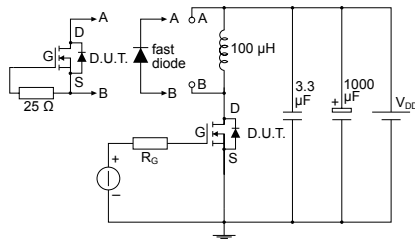
Figure 17. Test circuit for inductive load switching and diode recovery times

AM01470v1

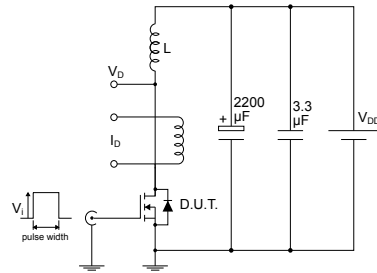
Figure 18. Unclamped inductive load test circuit

AM01471v1

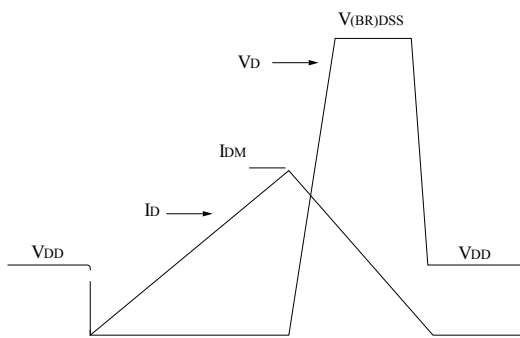
Figure 19. Unclamped inductive waveform

AM01472v1

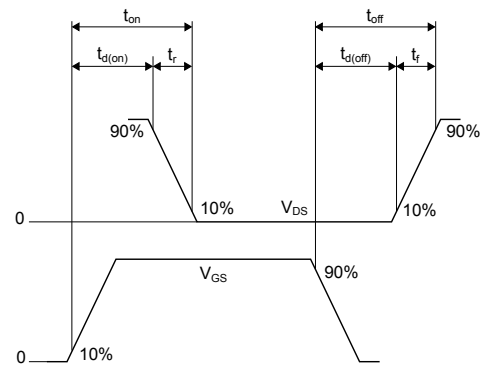
Figure 20. Switching time waveform

AM01473v1

4 Package information

In order to meet environmental requirements, ST offers these devices in different grades of ECOPACK® packages, depending on their level of environmental compliance. ECOPACK® specifications, grade definitions and product status are available at: www.st.com. ECOPACK® is an ST trademark.

4.1 DPAK (TO-252) type A package information

Figure 21. DPAK (TO-252) type A package outline

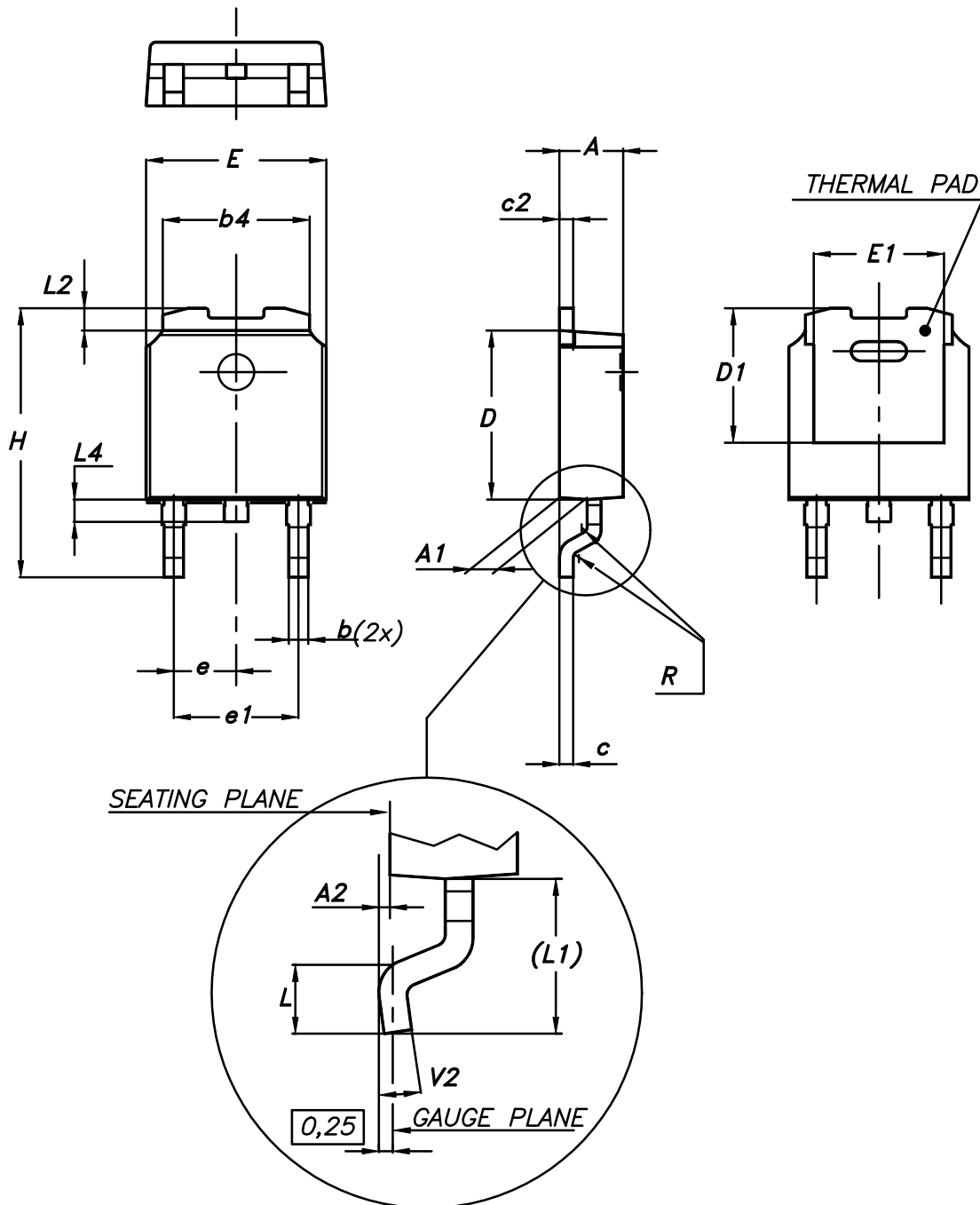

0068772_A_25

Table 8. DPAK (TO-252) type A mechanical data

Dim.	mm		
	Min.	Typ.	Max.
A	2.20		2.40
A1	0.90		1.10
A2	0.03		0.23
b	0.64		0.90
b4	5.20		5.40
c	0.45		0.60
c2	0.48		0.60
D	6.00		6.20
D1	4.95	5.10	5.25
E	6.40		6.60
E1	4.60	4.70	4.80
e	2.159	2.286	2.413
e1	4.445	4.572	4.699
H	9.35		10.10
L	1.00		1.50
(L1)	2.60	2.80	3.00
L2	0.65	0.80	0.95
L4	0.60		1.00
R		0.20	
V2	0°		8°

4.2 DPAK (TO-252) type E package information

Figure 22. DPAK (TO-252) type E package outline

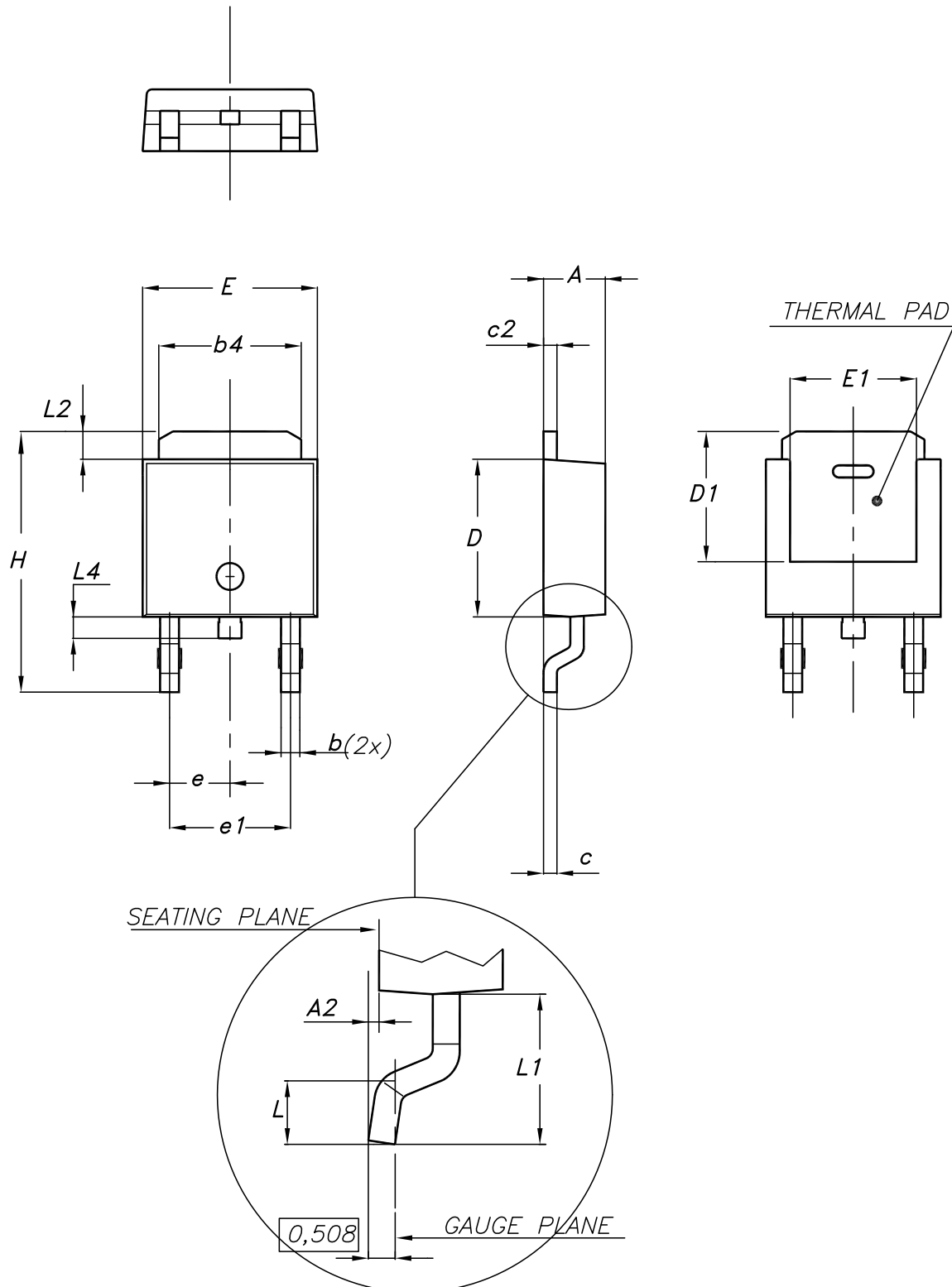
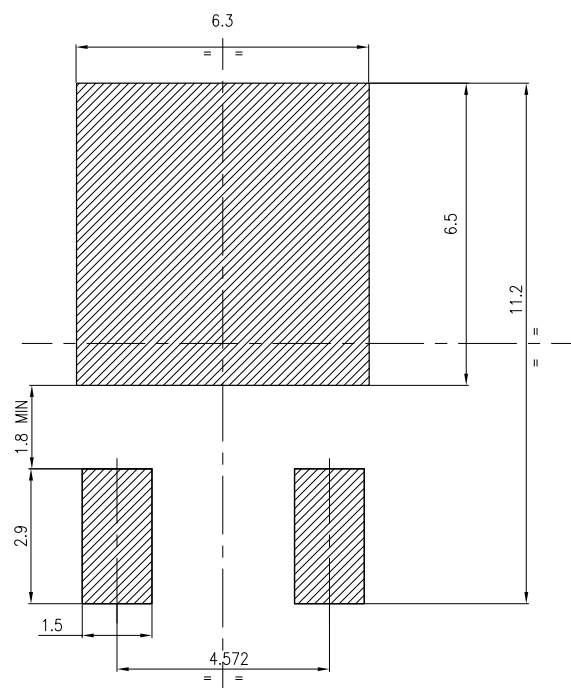

Table 9. DPAK (TO-252) type E mechanical data

Dim.	mm		
	Min.	Typ.	Max.
A	2.18		2.39
A2			0.13
b	0.65		0.884
b4	4.95		5.46
c	0.46		0.61
c2	0.46		0.60
D	5.97		6.22
D1	5.21		
E	6.35		6.73
E1	4.32		
e		2.286	
e1		4.572	
H	9.94		10.34
L	1.50		1.78
L1		2.74	
L2	0.89		1.27
L4			1.02

Figure 23. DPAK (TO-252) recommended footprint (dimensions are in mm)

FP_0068772_25

4.3 DPAK (TO-252) packing information

Figure 24. DPAK (TO-252) tape outline

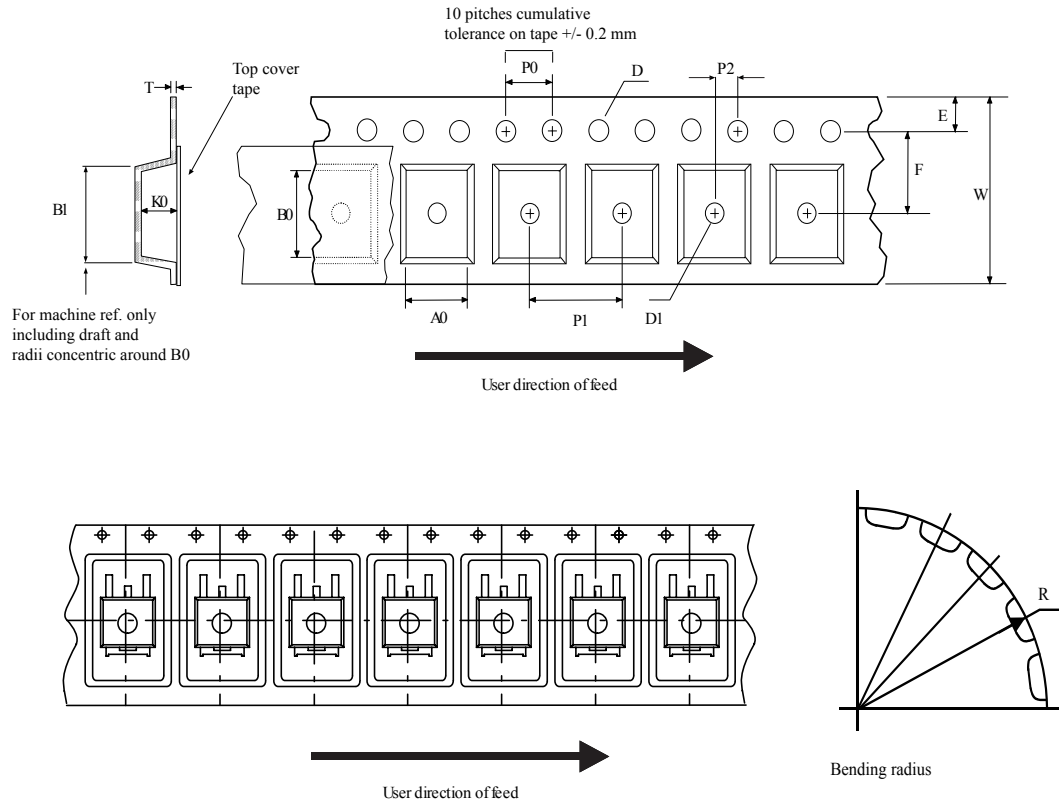

AM08852v1

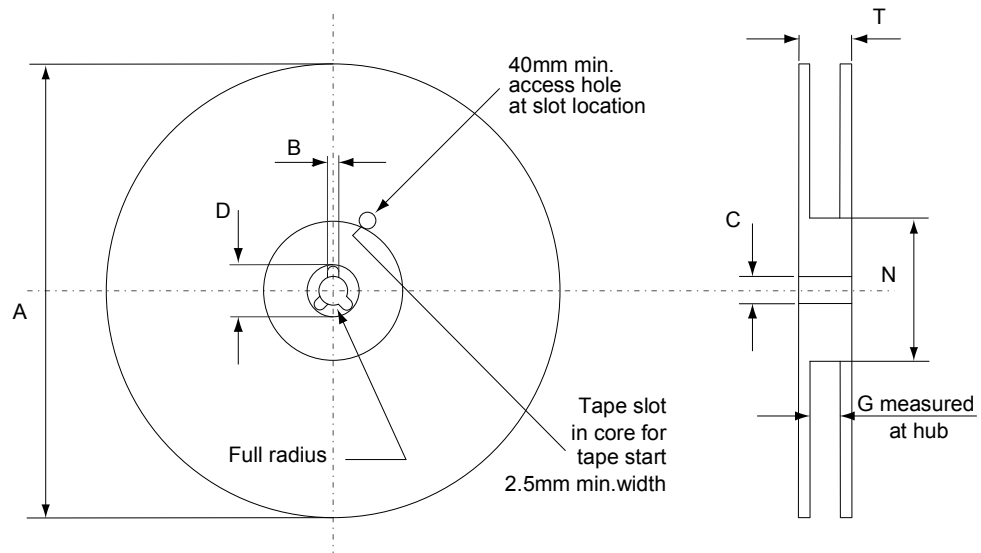
Figure 25. DPAK (TO-252) reel outline

AM06038v1

Table 10. DPAK (TO-252) tape and reel mechanical data

Tape			Reel		
Dim.	mm		Dim.	mm	
	Min.	Max.		Min.	Max.
A0	6.8	7	A		330
B0	10.4	10.6	B	1.5	
B1		12.1	C	12.8	13.2
D	1.5	1.6	D	20.2	
D1	1.5		G	16.4	18.4
E	1.65	1.85	N	50	
F	7.4	7.6	T		22.4
K0	2.55	2.75			
P0	3.9	4.1	Base qty.		2500
P1	7.9	8.1	Bulk qty.		2500
P2	1.9	2.1			
R	40				
T	0.25	0.35			
W	15.7	16.3			

4.4 TO-220 type A package information

Figure 26. TO-220 type A package outline

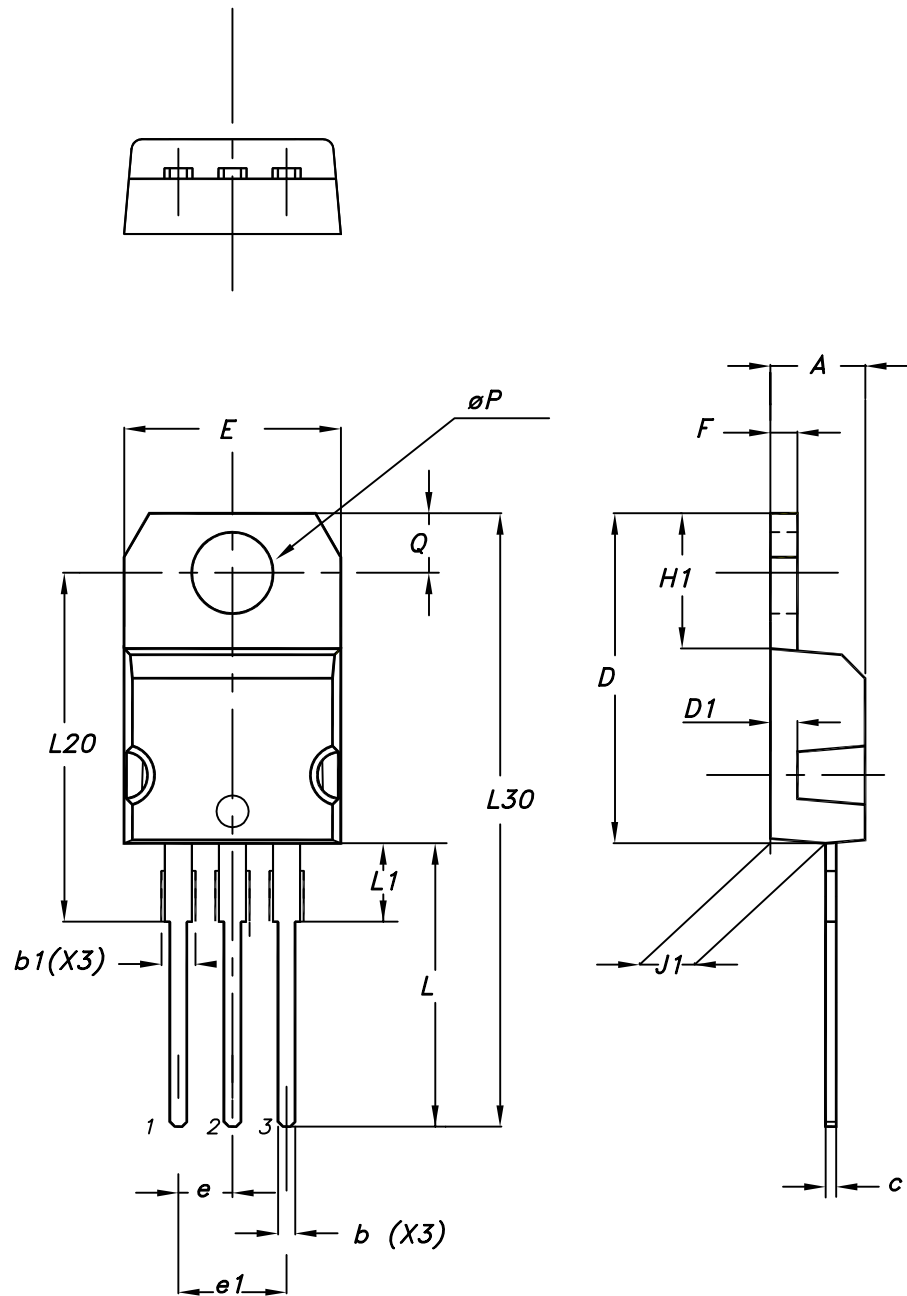

0015988_typeA_Rev_21

Table 11. TO-220 type A package mechanical data

Dim.	mm		
	Min.	Typ.	Max.
A	4.40		4.60
b	0.61		0.88
b1	1.14		1.55
c	0.48		0.70
D	15.25		15.75
D1		1.27	
E	10.00		10.40
e	2.40		2.70
e1	4.95		5.15
F	1.23		1.32
H1	6.20		6.60
J1	2.40		2.72
L	13.00		14.00
L1	3.50		3.93
L20		16.40	
L30		28.90	
øP	3.75		3.85
Q	2.65		2.95

4.5 TO-220FP package information

Figure 27. TO-220FP package outline

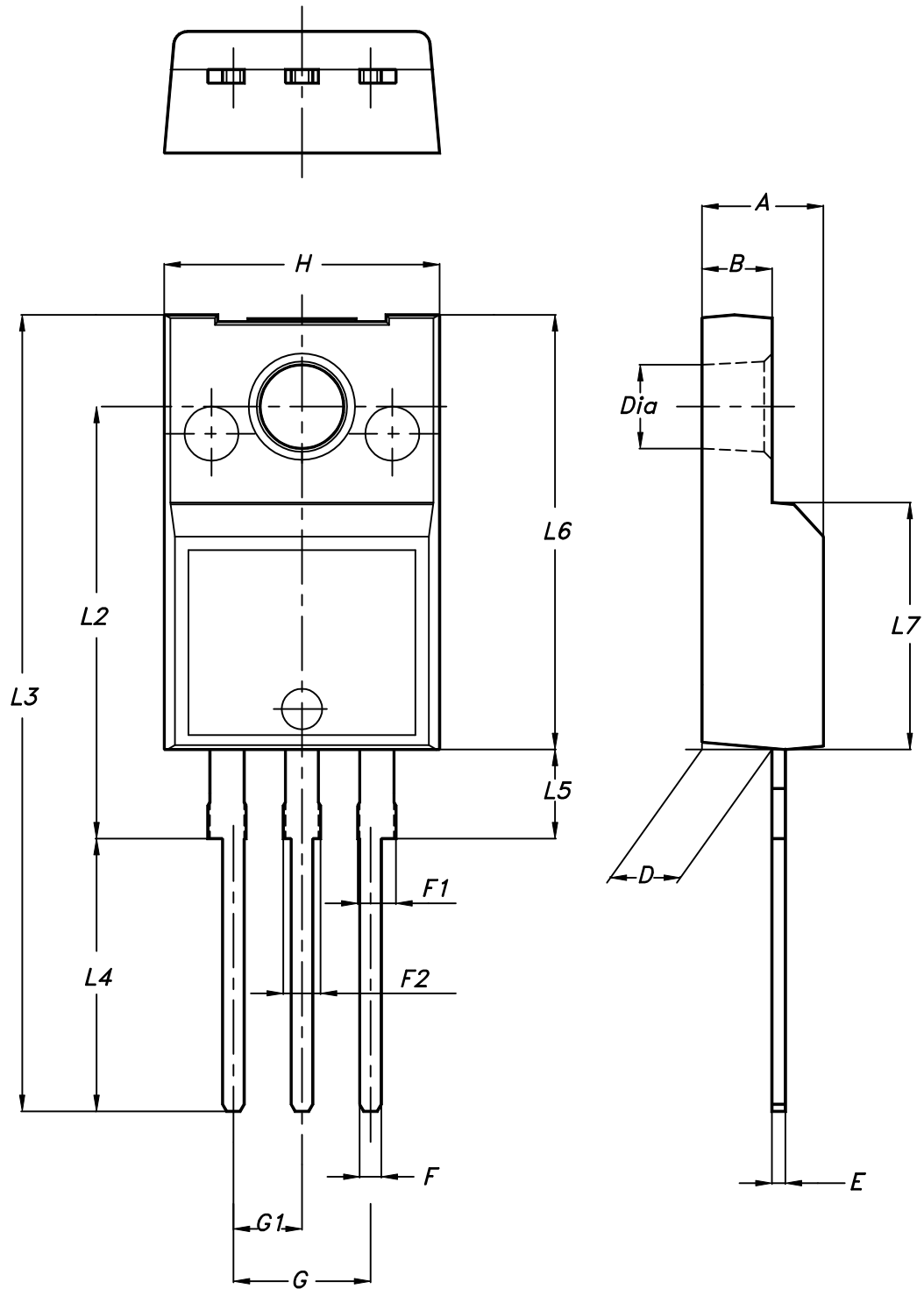

7012510_Rev_12_B

Table 12. TO-220FP package mechanical data

Dim.	mm		
	Min.	Typ.	Max.
A	4.4		4.6
B	2.5		2.7
D	2.5		2.75
E	0.45		0.7
F	0.75		1
F1	1.15		1.70
F2	1.15		1.70
G	4.95		5.2
G1	2.4		2.7
H	10		10.4
L2		16	
L3	28.6		30.6
L4	9.8		10.6
L5	2.9		3.6
L6	15.9		16.4
L7	9		9.3
Dia	3		3.2

Revision history

Table 13. Document revision history

Date	Version	Changes
02-Sep-2002	2	Document updated.
11-Jul-2018	3	Part number STD7NK40Z-1 was moved to a separate datasheet, and the document was updated accordingly. Updated title, features, applications and description on cover page. Updated Section 1 Electrical ratings , Section 2 Electrical characteristics , Section 3 Test circuits and Section 4 Package information . Minor text changes

Contents

1	Electrical ratings	2
2	Electrical characteristics	3
2.1	Electrical characteristics (curves)	5
3	Test circuits	8
4	Package information	9
4.1	DPAK (TO-252) type A package information	9
4.2	DPAK (TO-252) type E package information	11
4.3	DPAK (TO-252) packing information	13
4.4	TO-220 type A package information	15
4.5	TO-220FP package information	17
	Revision history	20

IMPORTANT NOTICE – PLEASE READ CAREFULLY

STMicroelectronics NV and its subsidiaries (“ST”) reserve the right to make changes, corrections, enhancements, modifications, and improvements to ST products and/or to this document at any time without notice. Purchasers should obtain the latest relevant information on ST products before placing orders. ST products are sold pursuant to ST’s terms and conditions of sale in place at the time of order acknowledgement.

Purchasers are solely responsible for the choice, selection, and use of ST products and ST assumes no liability for application assistance or the design of Purchasers’ products.

No license, express or implied, to any intellectual property right is granted by ST herein.

Resale of ST products with provisions different from the information set forth herein shall void any warranty granted by ST for such product.

ST and the ST logo are trademarks of ST. All other product or service names are the property of their respective owners.

Information in this document supersedes and replaces information previously supplied in any prior versions of this document.

© 2018 STMicroelectronics – All rights reserved

Компания «Life Electronics» занимается поставками электронных компонентов импортного и отечественного производства от производителей и со складов крупных дистрибьюторов Европы, Америки и Азии.

С конца 2013 года компания активно расширяет линейку поставок компонентов по направлению коаксиальный кабель, кварцевые генераторы и конденсаторы (керамические, пленочные, электролитические), за счёт заключения дистрибьюторских договоров

Мы предлагаем:

- Конкурентоспособные цены и скидки постоянным клиентам.
- Специальные условия для постоянных клиентов.
- Подбор аналогов.
- Поставку компонентов в любых объемах, удовлетворяющих вашим потребностям.
- Приемлемые сроки поставки, возможна ускоренная поставка.
- Доставку товара в любую точку России и стран СНГ.
- Комплексную поставку.
- Работу по проектам и поставку образцов.
- Формирование склада под заказчика.
- Сертификаты соответствия на поставляемую продукцию (по желанию клиента).
- Тестирование поставляемой продукции.
- Поставку компонентов, требующих военную и космическую приемку.
- Входной контроль качества.
- Наличие сертификата ISO.

В составе нашей компании организован Конструкторский отдел, призванный помогать разработчикам, и инженерам.

Конструкторский отдел помогает осуществить:

- Регистрацию проекта у производителя компонентов.
- Техническую поддержку проекта.
- Защиту от снятия компонента с производства.
- Оценку стоимости проекта по компонентам.
- Изготовление тестовой платы монтаж и пусконаладочные работы.



Тел: +7 (812) 336 43 04 (многоканальный)

Email: org@lifeelectronics.ru