

THIS DRAWING IS UNPUBLISHED. RELEASED FOR PUBLICATION 20  
 © COPYRIGHT 20 BY - ALL RIGHTS RESERVED.

REVISIONS					
P	LTR	DESCRIPTION	DATE	DWN	APVD
4		REVISED TO SHOW ALL WIRES	02OCT2015	JS	CG
5		NOTE CLARIFICATION	03NOV2015	MM	MM
6		REVISED TO SHOW PART CHANGES	29DEC2015	JS	CG

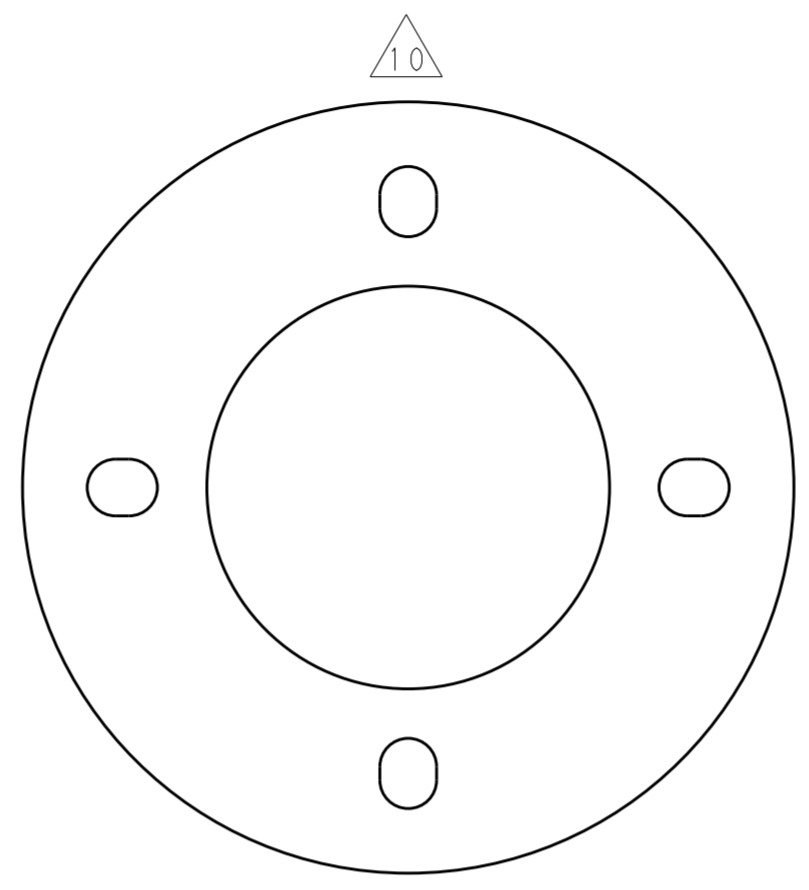

SEE SHEET 2 FOR WIRING COLOR CODE

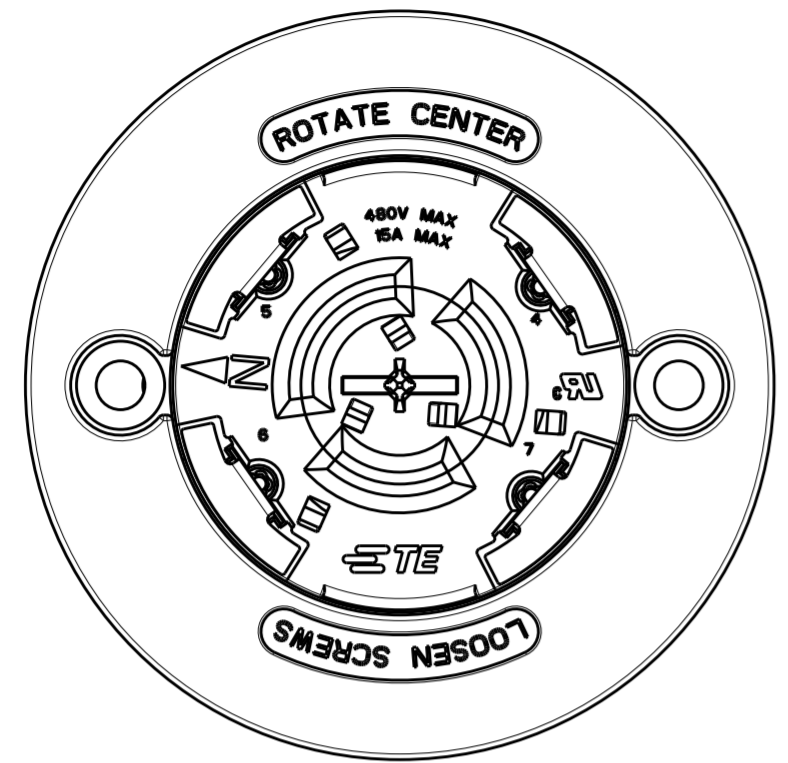
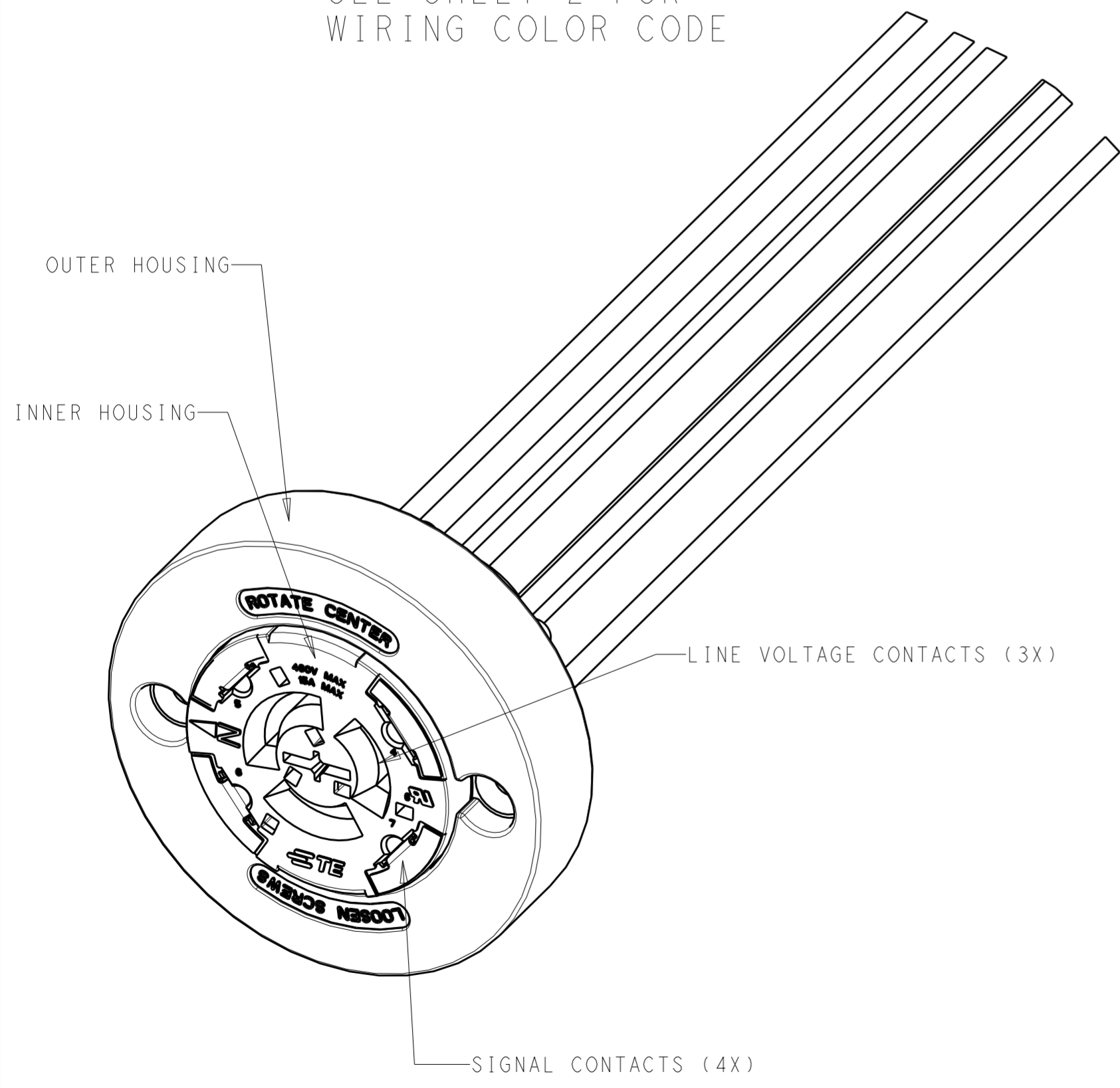

NOTES:

1. MATERIALS:  
 HOUSINGS: GLASS-FILLED THERMOPLASTIC, UL 94V-0 RATED  
 SIGNAL CONTACTS (2 OR 4) AND LINE VOLTAGE CONTACTS (3):  
 COPPER ALLOY
2. FINISH:  
 SIGNAL CONTACTS (2 OR 4): NICKEL UNDERPLATE ENTIRE  
 CONTACT 0.127 μm MIN THICK. GOLD PLATE CONTACT  
 PAD AREA (MATING FACE SIDE ONLY) 0.76 μm MIN THICK.  
 MATTE TIN PLATE TAB ON BOTH SIDES 0.30 μm MIN THICK.  
 LINE VOLTAGE CONTACTS (3): TIN PLATE.
3. LINE VOLTAGE CONDUCTORS (3):  
 14 AWG, 600V, 150°C RATED, COPPER 41/30 STRANDED  
 PER UL STYLE AWM 3321.
4. MATING INTERFACE PER ANSI C136.41-2013.
5. OPTIONAL SIGNAL CONTACTS (2) SUPPLIED WITH -2 AND -4 ONLY.
6. SIGNAL CONDUCTORS (2 OR 4):  
 18 AWG, 600V, 150°C RATED, 16/30 STRANDED,  
 PER UL STYLE AWM 3321.
7. LINE VOLTAGE CONDUCTORS (3):  
 14 AWG, 600V, 105°C RATED, COPPER 41/30 STRANDED.  
 PER UL STYLE AWM 1015.
8. SIGNAL CONDUCTORS (2 OR 4):  
 18 AWG, 600V, 105°C RATED, COPPER 16/30 STRANDED.  
 PER UL STYLE AWM 1015.
9. LUBRICATION: GOLD PLATED CONTACT PAD SURFACES OF SIGNAL  
 CONTACTS ARE LUBRICATED WITH A TRANSPARENT (NON-VISIBLE)  
 LUBRICANT TO IMPROVE DURABILITY AND PERFORMANCE. AVOID  
 CONTACT WITH THESE SURFACES WHICH MAY RESULT IN REMOVAL  
 OF LUBRICANT.
10. WHEN INCLUDED: SEALING GASKET (TE P/N 2213626-1)  
 SHIPPED IN PLACE ON ASSEMBLY AND RETAINED BY THE WIRE LEAD BUNDLE.

341.1	304.8	291.3	7 AND 8	Y	4 5	2213627-8
341.1	304.8	291.3	7 AND 8	Y	2	2213627-7
341.1	304.8	291.3	3 AND 6	Y	4 5	2213627-6
341.1	304.8	291.3	3 AND 6	Y	2	2213627-5
341.1	304.8	291.3	7 AND 8	N	4 5	2213627-4
341.1	304.8	291.3	7 AND 8	N	2	2213627-3
341.1	304.8	291.3	3 AND 6	N	4 5	2213627-2
341.1	304.8	291.3	3 AND 6	N	2	2213627-1
C	A	B	WIRE STYLE	GASKET 10	SIGNAL CONTACTS QUANTITY	PART NO.
OVERALL LENGTH	WIRE LENGTH					

NEW PRODUCT  
 PRELIMINARY  
 IN DEVELOPMENT

THIS DRAWING IS A CONTROLLED DOCUMENT.

DIMENSIONS:	TOLERANCES UNLESS OTHERWISE SPECIFIED:	DWN	07APR2015
mm	0 PLC ±	RAWLS	07APR2015
	1 PLC ±	CHK	07APR2015
	2 PLC ±	C	GINGRICH
	3 PLC ±	APVD	07APR2015
	4 PLC ±	C	GINGRICH
	ANGLES ±	PRODUCT SPEC	108-32059
	FINISH	APPLICATION SPEC	114-32148
MATERIAL		WEIGHT	

Customer Drawing

SCALE 1:2 SHEET 1 OF 3 REV 6

STE TE Connectivity  
 ASSEMBLY ROTATING DIMMING RECEPTACLE (49.22mm)

THIS DRAWING IS UNPUBLISHED. RELEASED FOR PUBLICATION 20  
 © COPYRIGHT 20 BY - ALL RIGHTS RESERVED.

REVISIONS				
P	LTR	DESCRIPTION	DATE	APVD
-	-	SEE SHEET 1	-	-

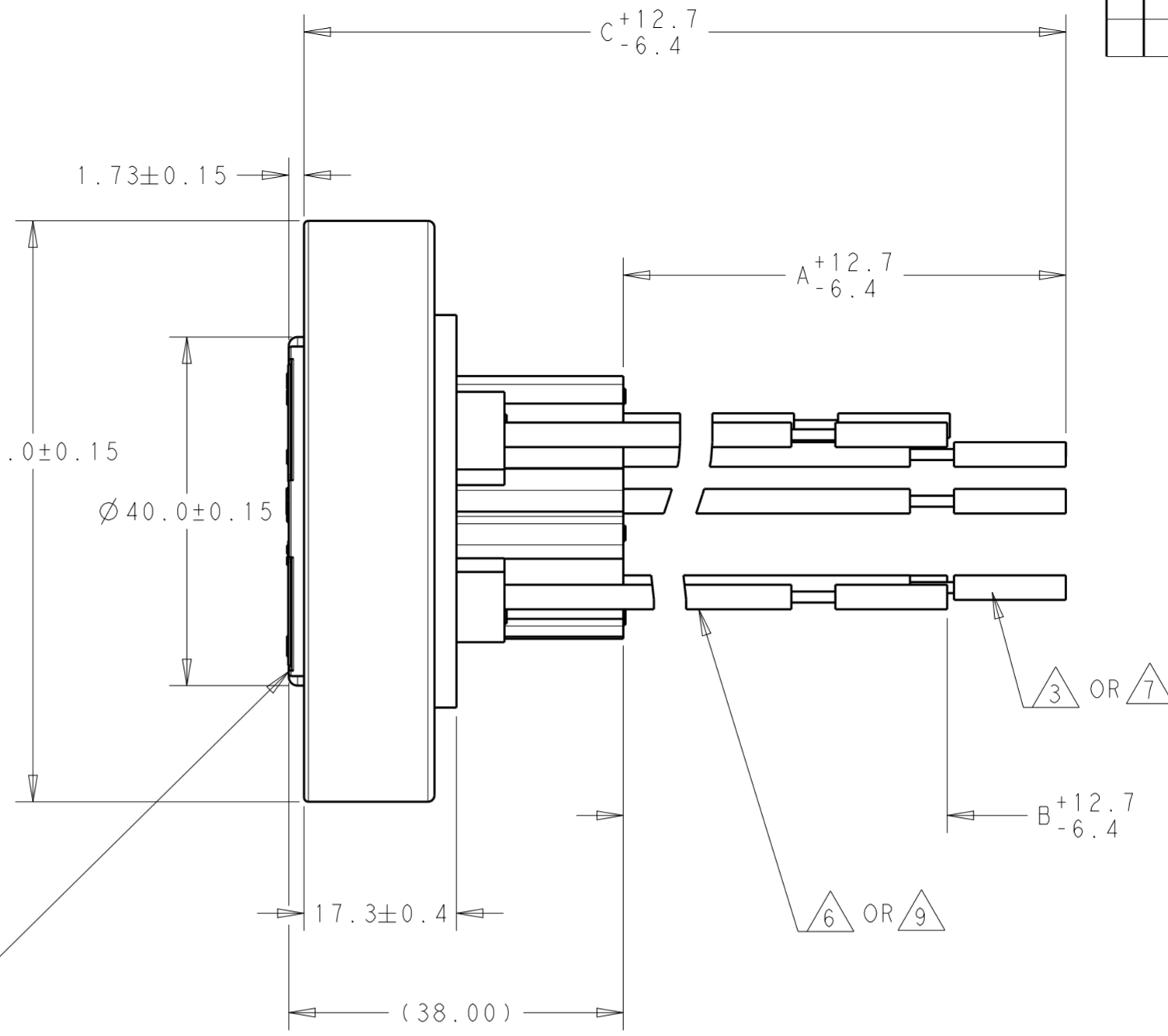
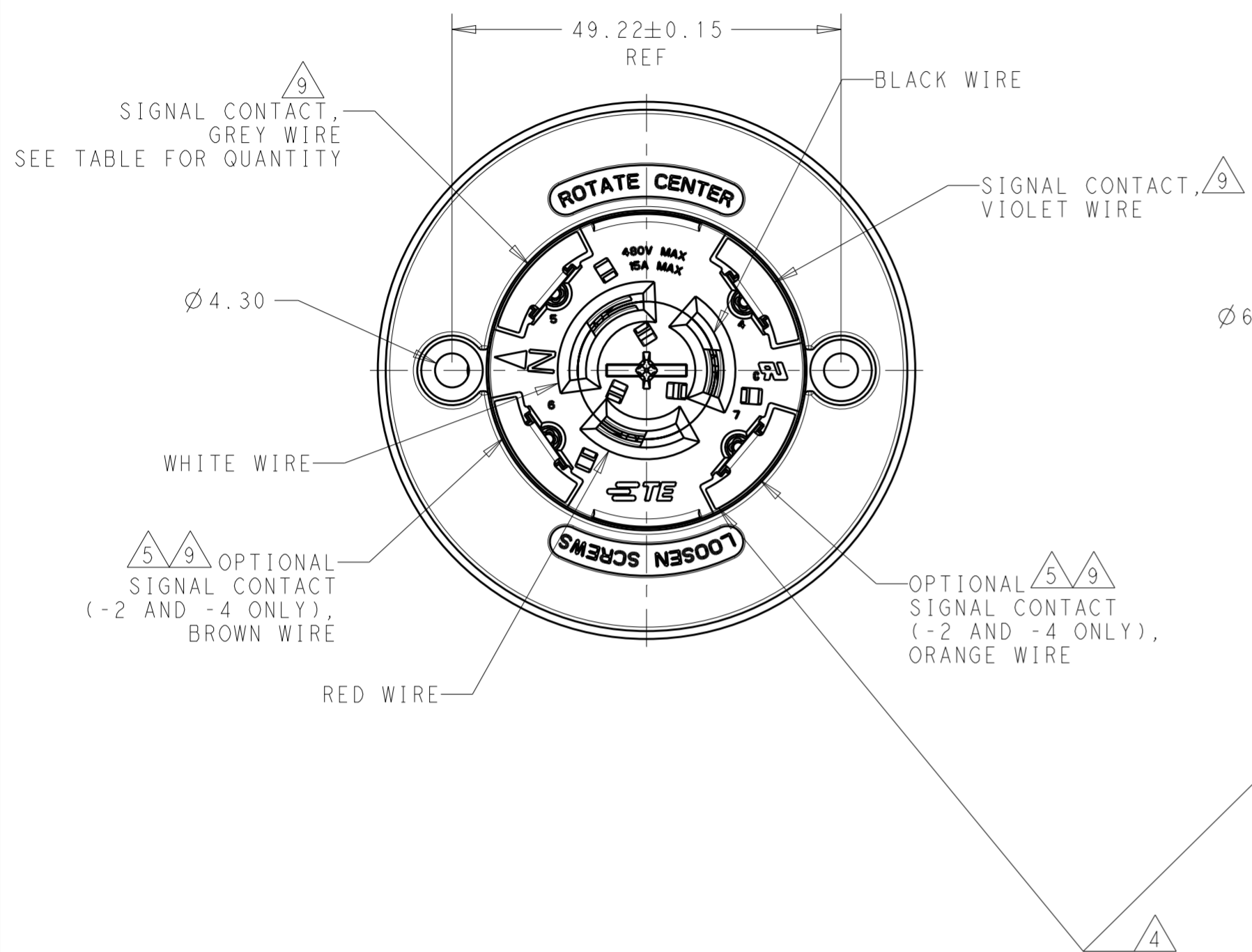

TYPE	POSITION #	WIRE COLOR
POWER	1	BLACK
POWER	2	WHITE
POWER	3	RED
SIGNAL	4	VIOLET
SIGNAL	5	GRAY
SIGNAL	6	BROWN
SIGNAL	7	ORANGE

NEW PRODUCT  
 PRELIMINARY  
 IN DEVELOPMENT

THIS DRAWING IS A CONTROLLED DOCUMENT.		DWN RAVLS 07APR2015	<b>STE</b> TE Connectivity	
DIMENSIONS: mm		CHK C. GINGRICH 07APR2015		
TOLERANCES UNLESS OTHERWISE SPECIFIED:		APVD C. GINGRICH 07APR2015	NAME ASSEMBLY ROTATING DIMMING RECEPTACLE (49.22mm),	
0 PLC ±		PRODUCT SPEC 108-32059	SIZE A2	
1 PLC ±		APPLICATION SPEC 114-32148	CAGE CODE -	
2 PLC ±		WEIGHT -	DRAWING NO C-2213627	
3 PLC ±		Customer Drawing	RESTRICTED TO -	
4 PLC ±			SCALE 1:2	
ANGLES ±			SHEET 2 OF 3	
FINISH -			REV 6	

THIS DRAWING IS UNPUBLISHED. RELEASED FOR PUBLICATION 20  
 © COPYRIGHT 20 BY - ALL RIGHTS RESERVED.

REVISIONS				
P	LTR	DESCRIPTION	DATE	APVD
-		SEE SHEET 1	-	-

IF THE LOCK RING BECOME SEPARATED FROM THE INNER HOUSING ASSEMBLY, FOLLOW THE THESE STEPS TO SNAP IT BACK INTO PLACE  
 TO ASSEMBLE THE LOCK RING ONTO THE INNER HOUSING, THESE STEPS MUST BE FOLLOWED.

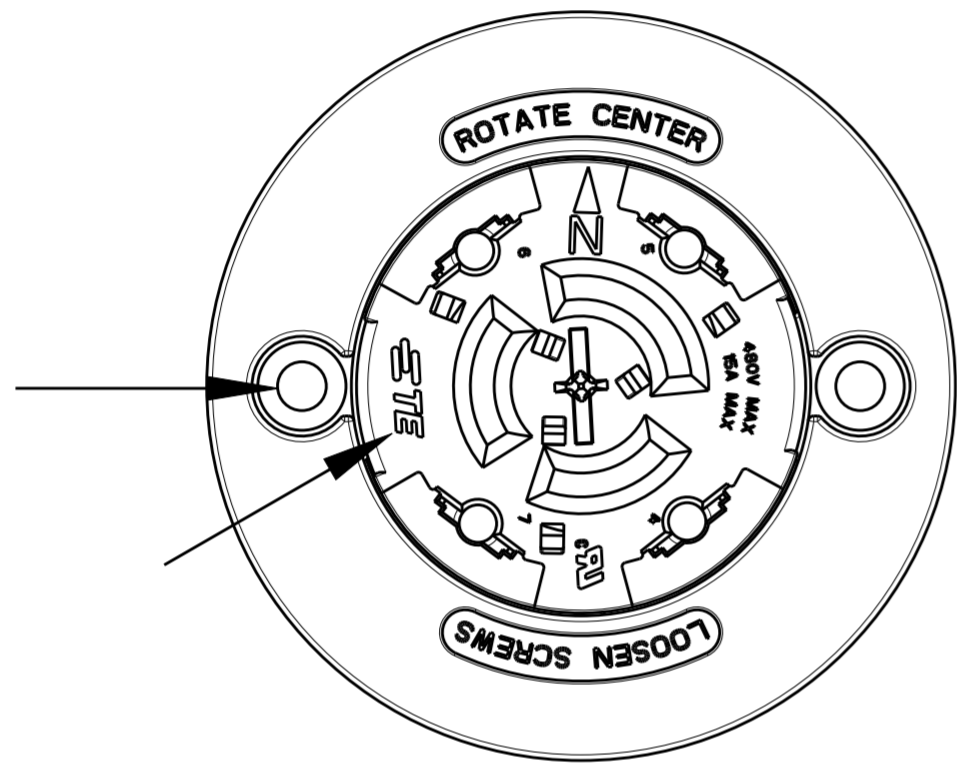

STEP 1: ALIGN THE TE LOGO WITH ONE OF THE SCREW HOLES ON THE LOCK RING.

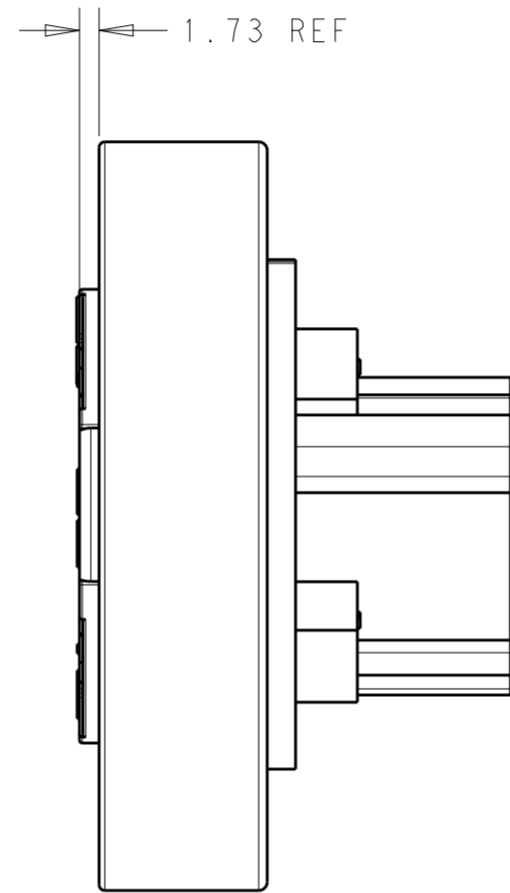

STEP 2: SNAP THE LOCK RING ONTO THE INNER HOUSING ASSEMBLY

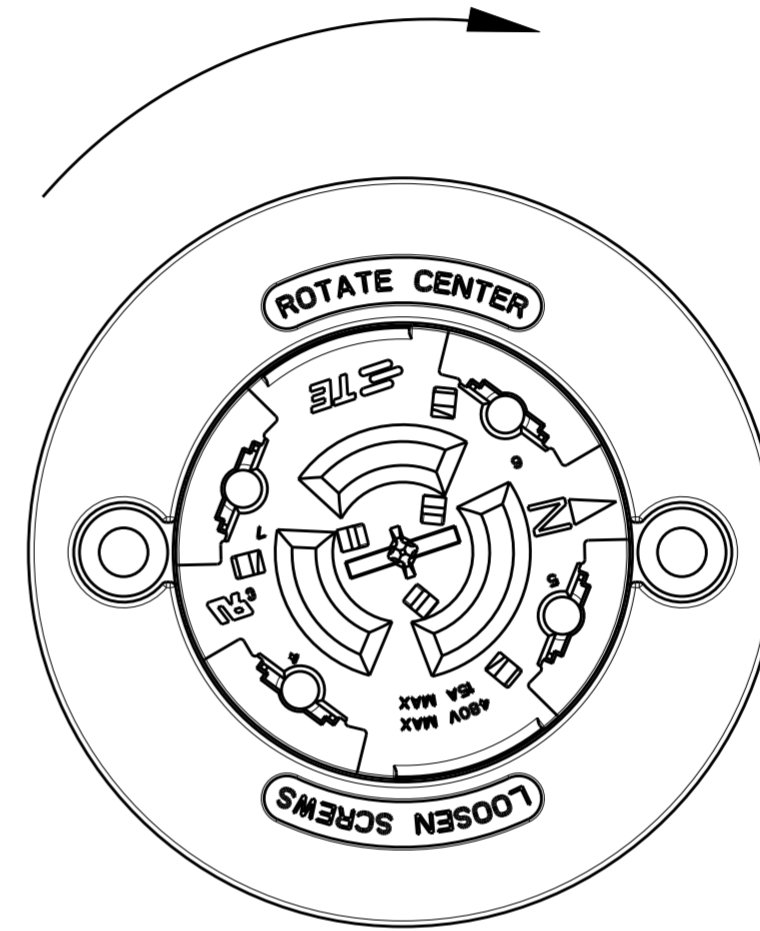

STEP 3: TURN THE LOCK RING FULLY CLOCKWISE UNTIL IT STOPS (THE NORTH INDICATOR WILL BE ADJACENT TO ONE OF THE SCREW HOLES IN THE LOCK RING)

NEW PRODUCT  
 PRELIMINARY  
 IN DEVELOPMENT

THIS DRAWING IS A CONTROLLED DOCUMENT.		DWN RAVLS 07APR2015	<b>STE</b> TE Connectivity	
DIMENSIONS: mm		CHK C. GINGRICH 07APR2015		
TOLERANCES UNLESS OTHERWISE SPECIFIED:		APVD C. GINGRICH 07APR2015	NAME ASSEMBLY ROTATING DIMMING RECEPTACLE (49.22mm),	
0 PLC ±		PRODUCT SPEC 108-32059	SIZE A2	
1 PLC ±		APPLICATION SPEC 114-32148	CAGE CODE -	
2 PLC ±		WEIGHT -	DRAWING NO C-2213627	
3 PLC ±		Customer Drawing	RESTRICTED TO -	
4 PLC ±			SCALE 1:2	
ANGLES ±			SHEET 3 OF 3	
FINISH -			REV 6	

Компания «Life Electronics» занимается поставками электронных компонентов импортного и отечественного производства от производителей и со складов крупных дистрибьюторов Европы, Америки и Азии.

С конца 2013 года компания активно расширяет линейку поставок компонентов по направлению коаксиальный кабель, кварцевые генераторы и конденсаторы (керамические, пленочные, электролитические), за счёт заключения дистрибьюторских договоров

Мы предлагаем:

- Конкурентоспособные цены и скидки постоянным клиентам.
- Специальные условия для постоянных клиентов.
- Подбор аналогов.
- Поставку компонентов в любых объемах, удовлетворяющих вашим потребностям.
- Приемлемые сроки поставки, возможна ускоренная поставка.
- Доставку товара в любую точку России и стран СНГ.
- Комплексную поставку.
- Работу по проектам и поставку образцов.
- Формирование склада под заказчика.
- Сертификаты соответствия на поставляемую продукцию (по желанию клиента).
- Тестирование поставляемой продукции.
- Поставку компонентов, требующих военную и космическую приемку.
- Входной контроль качества.
- Наличие сертификата ISO.

В составе нашей компании организован Конструкторский отдел, призванный помогать разработчикам, и инженерам.

Конструкторский отдел помогает осуществить:

- Регистрацию проекта у производителя компонентов.
- Техническую поддержку проекта.
- Защиту от снятия компонента с производства.
- Оценку стоимости проекта по компонентам.
- Изготовление тестовой платы монтаж и пусконаладочные работы.



Тел: +7 (812) 336 43 04 (многоканальный)

Email: [org@lifeelectronics.ru](mailto:org@lifeelectronics.ru)