

SMT/QuickGrip Connectors

Product Facts

- Solderless Cable Termination
- 3.0 [.118] Mated Height
- Excellent Cable Retention
- Usable With Flexible and Semi-Rigid Micro-Coaxial Cables
- Tape and Reel Packaging

Tyco Electronics revolutionary SMT/QuickGrip product line is designed to meet the growing demand for a reliable, low cost system for direct termination of coax to a printed circuit board (PCB). SMT/QuickGrip technology eliminates the requirement to connectorize the coaxial cable, reducing assembly times and, therefore, cost. The SMT/QuickGrip surface mount device occupies less PCB area than conventional through hole coaxial connectors. An innovative microstrip mounting pattern and cable receptacle design ensures excellent grounding and PCB retention. The SMT/QuickGrip cable termination system stands a mere 3.0 [.118] off the board when mated, allowing for closer pitch/spacing when designing a

system. The SMT/QuickGrip design provides optimal cable retention for applications where shock, vibration, and/or cable flexure may be encountered. This unique RF design accepts both flexible and semi-rigid micro-coaxial cables while delivering exceptional RF performance up to 3GHz.

These features make this system extremely versatile for design engineers and offer a reliable, cost effective alternative to direct soldering of cable to the PCB. The cable is inserted into the device by means of a simple self-aligning hand tool, eliminating the requirement for skilled personnel. This system removes the possibility of damaged PCBs and cables which are common quality issues associated with direct solder, while providing superior RF performance. The SMT/QuickGrip accommodates multiple cable insertions allowing easy replacement of cables for repairs. This receptacle is designed for high volume assembly using surface mount technology and is available in tape and reel packaging for pick and place board assembly. Pre-stripped cables and inter-

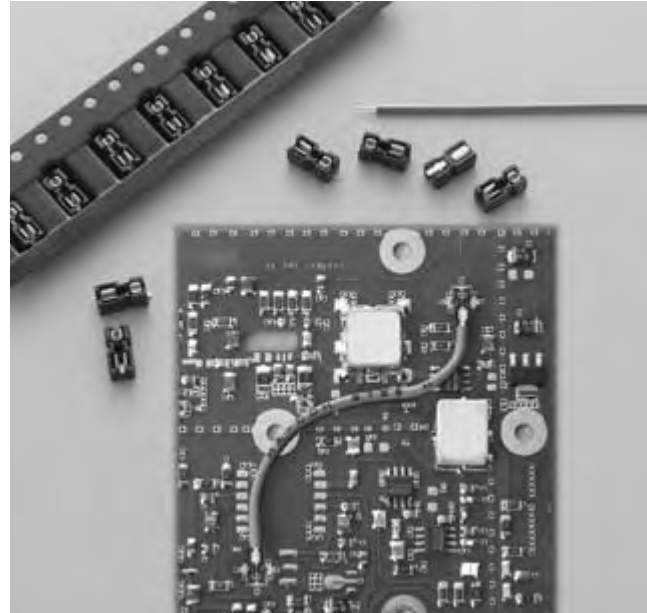

series cable pigtails are available as turnkey solutions for your application needs (i.e.: for use in multi-board applications, for connecting antennas to the PCB, or point to point transmission on the same PCB).

The SMT/QuickGrip cable termination system is ideal for wireless surface mount applications in handsets, pagers and personal digital assistants (PDA). The SMT/QuickGrip

mechanical and electrical performance, coupled with its ease of use, ensure it to be a high quality, reliable solution for current and future interconnect needs. Tyco Electronics is an ISO9001 certified manufacturer and maintains an SPC controlled manufacturing environment. Please call your local Sales or Distribution office for additional information and qualification samples today.

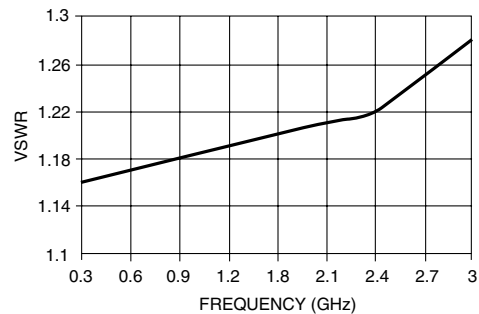
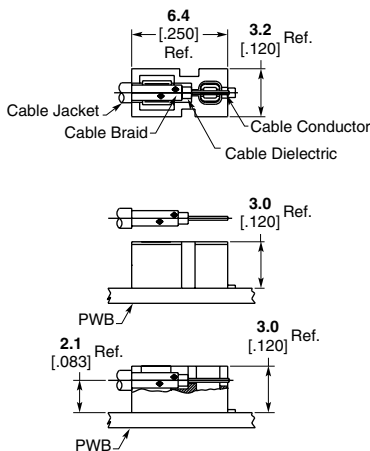

Typical VSWR using SMT/QuickGrip with Omni-Flex 200 Cable

Omni-Flex 200 cable is a Tyco Electronics specified cable.

SMT/QuickGrip Connectors (Continued)

Specifications

General

| | |
|------------------|-----------------------------|
| Materials | |
| Housing: | Polyphenylene Sulfide (PPS) |
| Contacts: | Copper Alloy |
| Finishes | |
| Contacts: | Gold Plate over Nickel |

Electrical

| | |
|------------------|--|
| Frequency Range: | DC - 3GHz |
| Impedance: | Usable with 50 & 75 Ohm systems |
| Insertion Loss: | .08 \sqrt{f} GHz |
| DWV: | 750 VRMs |
| VSWR: | 1.3:1 @ 3GHz (Omni-Flex 200 and .047 [.002] Semi-Rigid) 1.4:1 @ 3GHz (.034 [.001] Semi-Rigid) |

Mechanical

| | |
|--|--|
| Connector Durability: | 5 mating cycles min. (receptacle only) |
| Tape and Reel Packaging: | 16 [.629] per EIA-481 |
| Force to Disengage by Cam-Out (grams): | Omni-Flex 200 Cable - 543 typical .034 [.001] Semi-Rigid - 852 typical .047 [.002] Semi-Rigid - 1066 typical |

Environmental

| | |
|----------------------------|---|
| Temperature Rating: | -40°C(-40°F) to 125°C(257°F) when mated with Omni-Flex 200 Cable |
| Resistance to Solder Heat: | Infrared, convection, and vapor phase solderable (receptacle only). Maximum reflow time/temperature not to exceed 260°C for 3 minutes. |

Cable Information

| | |
|--|---|
| Materials: | |
| Jacket: | FEP Flexible Cable (200°C) |
| Shield: | Fluorinated Ethylene Propylene |
| Dielectric: | Silver plated copper wire, 44 AWG, 90% min. coverage |
| Center Conductor: | PTFE (Polytetrafluoroethylene) |
| Center Conductor: | Silver Plated Copper Clad Steel, 30 AWG |
| Minimum Bend Radius: | 6.35 [.250] |
| Insertion Loss (PVC and FEP cable only): | 1.3dB/m, 0.4 dB/ft. @ 500 MHz 2.0dB/m, 0.5 dB/ft. @ 1 GHz 3.0dB/m, 0.9 dB/ft. @ 2 GHz |
| Center Conductor Resistance: | .26 Ohms per foot average |

Strip Dimensions

**Tyco Electronics
Omni-Flex 200 Cable
Part Number 1407578-1**

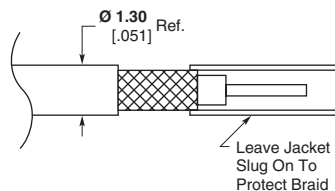

**Semi-Rigid Cable
(.034 and .047)**

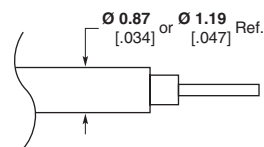

Omni-Flex 200 cable is a Tyco Electronics specified cable.

Note: Part Numbers are RoHS compliant except: ♦ Indicates non-RoHS compliant.

SMT/QuickGrip Connectors (Continued)

PC Board Mount Receptacle

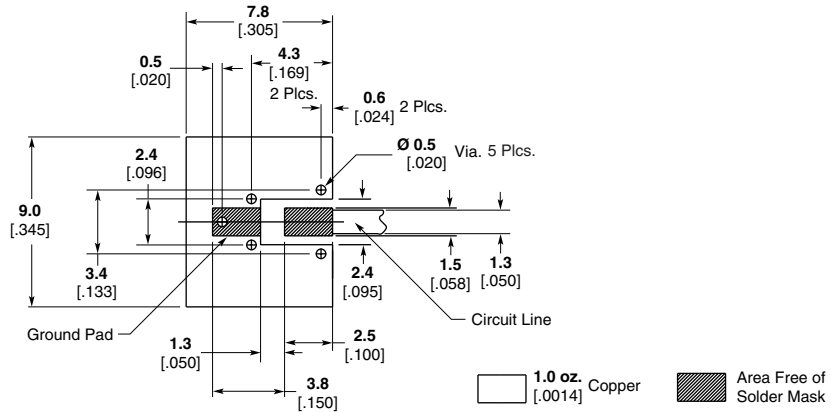
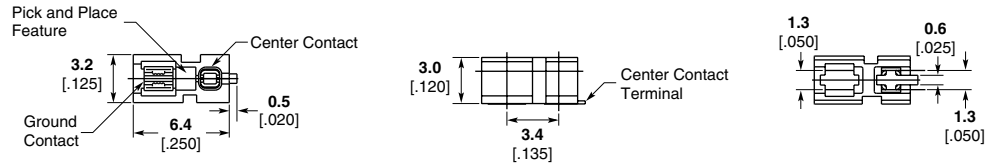

Recommended Mounting Pattern for Microstrip Line

| Description | Part No. |
|-----------------------|------------------|
| Bulk Packaged 100/bag | 1085456-1 |
| 700 Piece Reel | 1086008-1 |
| 2000 Piece Reel | 1086009-1 |

1. Printed wiring board material: glass epoxy FR-4 or similar, relative permittivity: 4.8, 1 oz. copper clad both sides.
2. These dimensions valid for 1.6 [.062] board thickness.

Cable Insertion Tool



| Part No. |
|------------------|
| 1088313-1 |

Note: Part Numbers are RoHS compliant except: ♦ Indicates non-RoHS compliant.

SMT/QuickGrip Connectors (Continued)

Inter-Series Cable Assemblies



SMA Straight Plug

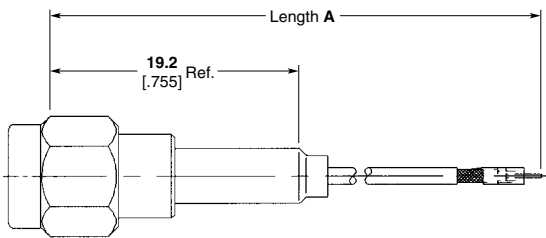

| Cable | Assembly Length (A) | Part No. |
|---------------|---------------------|------------------|
| Omni-Flex 200 | 100 [4] | 1329174-1 |
| | 200 [8] | 1329174-2 |
| | 305 [12] | 1310432-1 |

Note:

1. Cable length tolerances: Length 'A' mm [In], Tolerance mm [In],
 50 to 100 [3.94], ± 3 [± .12], 101 to 500 [3.98 to 19.69], ± 5 [± .20],
 Over 500 [19.69], ± 10 [± .39]

SMA Bulkhead Jack

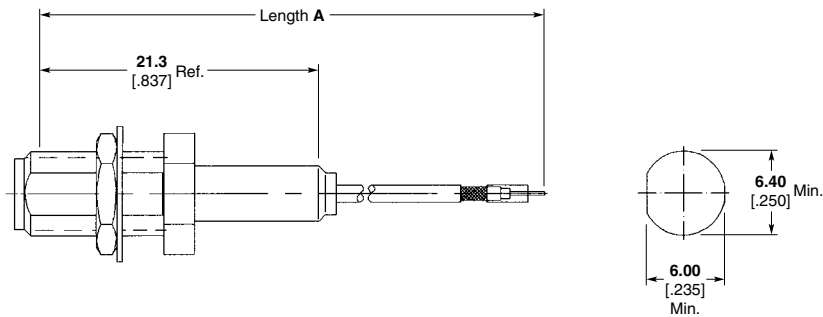

Recommended Mounting Hole

| Cable | Assembly Length (A) | Part No. |
|---------------|---------------------|------------------|
| Omni-Flex 200 | 100 [4] | 1329175-1 |
| | 200 [8] | 1329175-2 |
| | 305 [12] | 1329175-3 |

Note:

1. Cable length tolerances: Length 'A' mm [In], Tolerance mm [In],
 50 to 100 [3.94], ± 3 [± .12], 101 to 500 [3.98 to 19.69], ± 5 [± .20],
 Over 500 [19.69], ± 10 [± .39]

Omni-Flex 200 cable is a Tyco Electronics specified cable.

Note: Part Numbers are RoHS compliant except: ♦ Indicates non-RoHS compliant.

SMT/QuickGrip Connectors (Continued)

Inter-Series Cable Assemblies (Continued)

SMB Bulkhead Jack

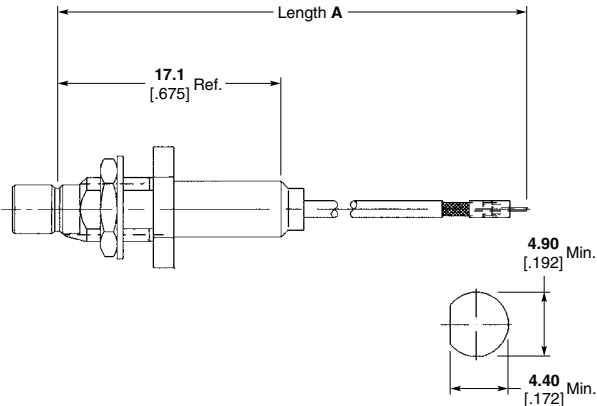

Recommended Mounting Hole

| Cable | Assembly Length (A) | Part No. |
|---------------|---------------------|-----------|
| Omni-Flex 200 | 100 [4] | 1408050-4 |
| | 200 [8] | 1408050-5 |
| | 305 [12] | 1408050-6 |

Note:

1. Cable length tolerances: Length 'A' mm [In], Tolerance mm [In],
50 to 100 [3.94], ± 3 [± .12], 101 to 500 [3.98 to 19.69], ± 5 [± .20],
Over 500 [19.69], ± 10 [± .39]

SMB Right-Angle Plug

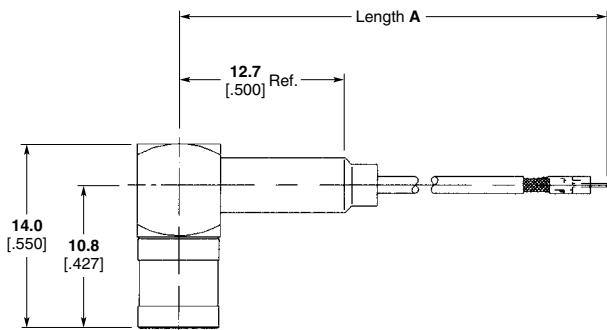

| Cable | Assembly Length (A) | Part No. |
|---------------|---------------------|-----------|
| Omni-Flex 200 | 100 [4] | 1255378-4 |
| | 200 [8] | 1255378-5 |
| | 305 [12] | 1255378-6 |

Note:

1. Cable length tolerances: Length 'A' mm [In], Tolerance mm [In],
50 to 100 [3.94], ± 3 [± .12], 101 to 500 [3.98 to 19.69], ± 5 [± .20],
Over 500 [19.69], ± 10 [± .39]

MCX Bulkhead Jack

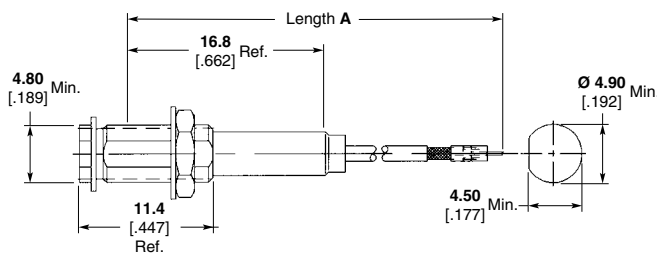

Recommended Mounting Hole

| Cable | Assembly Length (A) | Part No. |
|---------------|---------------------|-----------|
| Omni-Flex 200 | 100 [4] | 1408051-4 |
| | 200 [8] | 1408051-5 |
| | 305 [12] | 1408051-6 |

Note:

1. Cable length tolerances: Length 'A' mm [In], Tolerance mm [In],
50 to 100 [3.94], ± 3 [± .12], 101 to 500 [3.98 to 19.69], ± 5 [± .20],
Over 500 [19.69], ± 10 [± .39]

MCX Right-Angle Plug

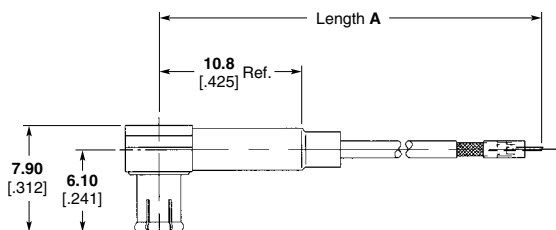

| Cable | Assembly Length (A) | Part No. |
|---------------|---------------------|-----------|
| Omni-Flex 200 | 100 [4] | 1330401-4 |
| | 200 [8] | 1330401-5 |
| | 305 [12] | 1330401-6 |

Note:

1. Cable length tolerances: Length 'A' mm [In], Tolerance mm [In],
50 to 100 [3.94], ± 3 [± .12], 101 to 500 [3.98 to 19.69], ± 5 [± .20],
Over 500 [19.69], ± 10 [± .39]

Omni-Flex 200 cable is a Tyco Electronics specified cable.

Note: Part Numbers are RoHS compliant except: ♦ Indicates non-RoHS compliant.

Компания «Life Electronics» занимается поставками электронных компонентов импортного и отечественного производства от производителей и со складов крупных дистрибьюторов Европы, Америки и Азии.

С конца 2013 года компания активно расширяет линейку поставок компонентов по направлению коаксиальный кабель, кварцевые генераторы и конденсаторы (керамические, пленочные, электролитические), за счёт заключения дистрибьюторских договоров

Мы предлагаем:

- Конкурентоспособные цены и скидки постоянным клиентам.
- Специальные условия для постоянных клиентов.
- Подбор аналогов.
- Поставку компонентов в любых объемах, удовлетворяющих вашим потребностям.
- Приемлемые сроки поставки, возможна ускоренная поставка.
- Доставку товара в любую точку России и стран СНГ.
- Комплексную поставку.
- Работу по проектам и поставку образцов.
- Формирование склада под заказчика.
- Сертификаты соответствия на поставляемую продукцию (по желанию клиента).
- Тестирование поставляемой продукции.
- Поставку компонентов, требующих военную и космическую приемку.
- Входной контроль качества.
- Наличие сертификата ISO.

В составе нашей компании организован Конструкторский отдел, призванный помогать разработчикам, и инженерам.

Конструкторский отдел помогает осуществить:

- Регистрацию проекта у производителя компонентов.
- Техническую поддержку проекта.
- Защиту от снятия компонента с производства.
- Оценку стоимости проекта по компонентам.
- Изготовление тестовой платы монтаж и пусконаладочные работы.



Тел: +7 (812) 336 43 04 (многоканальный)

Email: org@lifeelectronics.ru