



**Microtips**  
**TECHNOLOGY**

Model No: MTÖ€GG€ÓT Õ

TEL: 1-888-499-TIPS (8477)

FAX: (407) 273-0771

E-MAIL: [mtusainfo@microtipsusa.com](mailto:mtusainfo@microtipsusa.com)

WEB: [www.microtipsusa.com](http://www.microtipsusa.com)

## Record of Revision

Date	Revision No.	Summary
2010-04-20	1.0	Rev 1.0 was issued
2012-09-03	2.0	IC update
2015-10-14	3.0	Update the panel

### 1. Scope

This data sheet is to introduce the specification of **MTD0220BMG** active matrix 262k color TFT module. It is composed of a color TFT-LCD panel, driver ICs, FPC and a backlight unit. The 2.2' ' display area contains 240 (RGB) x 320 pixels.

### 2. Application

Digital equipments which need color display outdoor, mobile navigator/video systems.

### 3. General Information

Item	Contents	Unit
Size	2.2	inch
Resolution	240(RGB) X 320	/
Interface	RGB 18 bits+SPI	/
Color Depth	262K dithering	/
Technology type	a-si TFT	/
Pixel pitch	0.141x0.141	mm
Pixel Configuration	R.G.B. Vertical Stripe	
Outline Dimension (W x H x D)	40.6x56.6x2.7	mm
Active Area	33.84 x45.12	mm
Display Mode	Transflective (ECB)	/
Viewing Direction	12 o'clock	/
Backlight Type	LED	/
Driver IC	ILI9341	/



**5. Interface signals**

No	Symbol	Description	Remarks
1	VL1 ( LED+ )	Power supply for LED(High voltage)	
2	VL2 ( LED- )	Power supply for LED(Low voltage)	
3	GND	Ground	
4	VDD	Power supply of gate driver(high level)	
5	GND	Ground	
6	VSYNC	Vertical sync. signal	
7	RESET	Reset Enable	
8	GND	Ground	
9	CS	SPI Chip select	
10	SDO	SPI serial Data output	
11	SDI	SPI serial Data input	
12	GND	Ground	
13	SCL	SPI serial interface clock	
14	GND	Ground	
15	B5	Blue data signal	
16	B4	Blue data signal	
17	B3	Blue data signal	
18	B2	Blue data signal	
19	B1	Blue data signal	
20	B0	Blue data signal	
21	ENABLE	Data enable signal	
22	HSYNC	Horizontal sync signal	
23	GND	Ground	
24	DCLK	Data sampling clock signal	
25	GND	Ground	
26	G5	Green data signal	
27	G4	Green data signal	
28	G3	Green data signal	
29	G2	Green data signal	
30	G1	Green data signal	
31	G0	Green data signal	
32	GND	Ground	
33	R5	Red data signal	
34	R4	Red data signal	
35	R3	Red data signal	
36	R2	Red data signal	
37	R1	Red data signal	
38	R0	Red data signal	
39	GND	Ground	

Corresponded connector:FH23-39S-0.3SHW

## 6. Absolute maximum Ratings

### 6.1. Electrical Absolute max. ratings

Parameter	Symbol	MIN	MAX	Unit	Remark
Power Supply Voltage	VCI	-0.3	4.6	V	
Power Supply Voltage for logic	VDDI	-0.3	4.6	V	
Logic input voltage Range	VIN	-0.3	VDDI+0.3	V	

VIN: R0~R5,G0~G5,B0~B5, ENABLE,DCLK,HSYNC,VSNC,/CS,SCL,SDI,SDO/RESET

### 6.2. Environment Conditions

Item	Symbol	MIN	MAX	Unit	Remark
Operating Temperature	TOPR	-20	70	°C	
Storage Temperature	TSTG	-30	80	°C	

### 6.3. LED Backlight Absolute max. ratings

Item	Symbol	MIN	MAX	Unit	Remark
Back Light Forward Current	ILED	--	25	mA	

## 7. Electrical Specifications

### 7.1 Electrical characteristics

GND=0V, Ta=25°C

Item	Symbol	MIN	TYP	MAX	Unit	Remark
Supply Voltagefor analoge	VDD	2.5	2.8	3.3	V	
Input Signal Voltage	Low Level	VIL	VSS	--	0.3*VDDI	V
	High Level	VIH	0.7*VDDI	--	VDDI	V
Output Signal Voltage	Low Level	VOL	VSS	--	0.2*VDDI	V
	High Level	VOH	0.8*VDDI	--	VDDI	V
Supply Voltagefor digital	VDDI	1.65	2.8	3.3	V	

### 7.2 LED Backlight

Ta=25°C

Item	Symbol	MIN	TYP	MAX	Unit	Remark
Forward Current	IF	--	20	25	mA	4LEDs serial
Forward Voltage	VF	--	12.8	--	V	
Power Consumption	WBL	--	256	--	mW	
LED life time	--	10,000	20,000	--	Hrs	

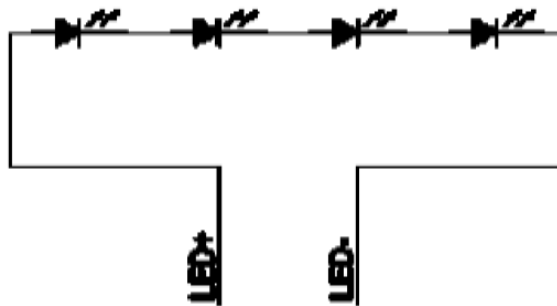

7.3 Schematic of LCD module system

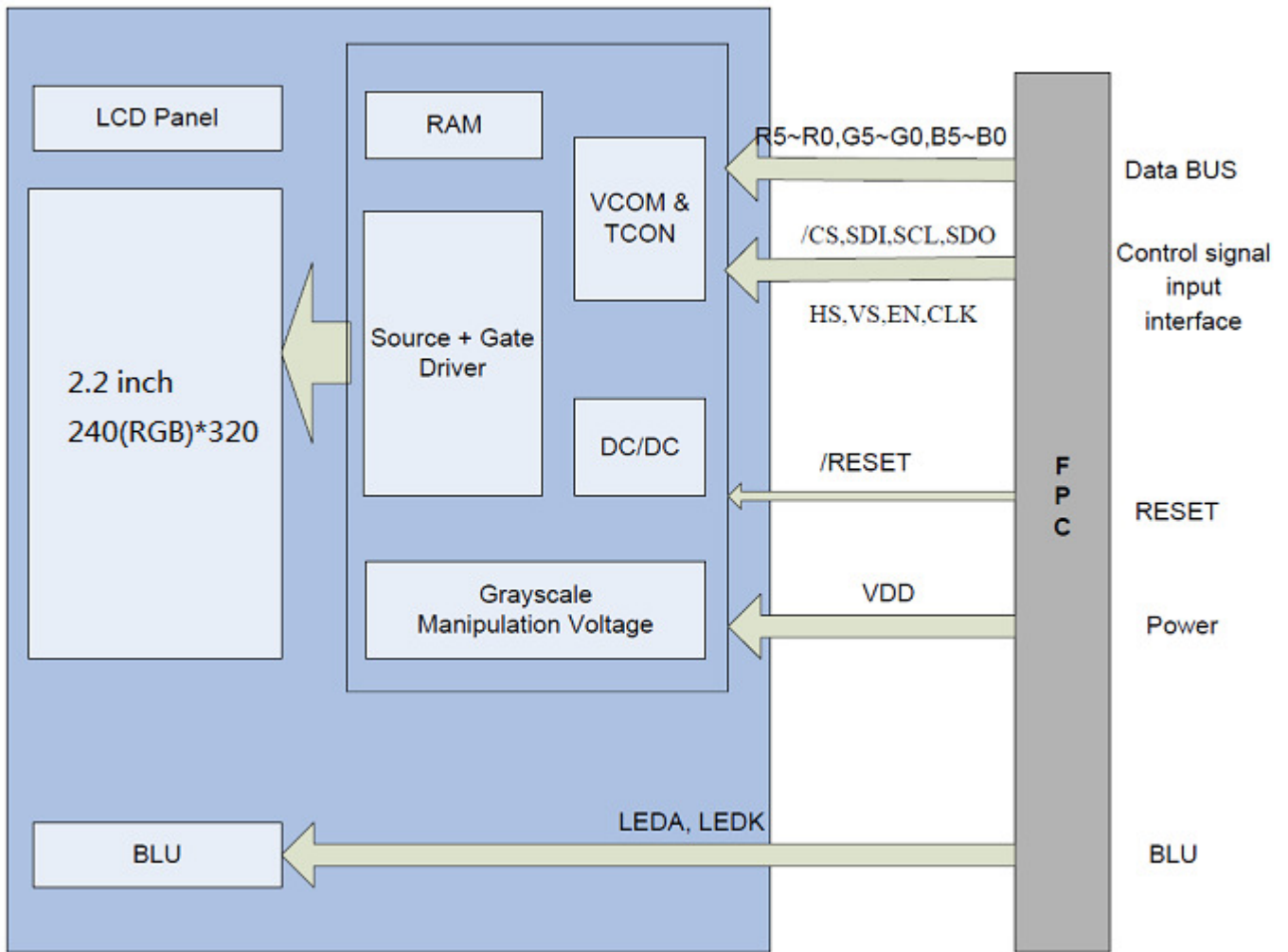



## 8. Command/AC Timing

### 8.1 AC Characteristics

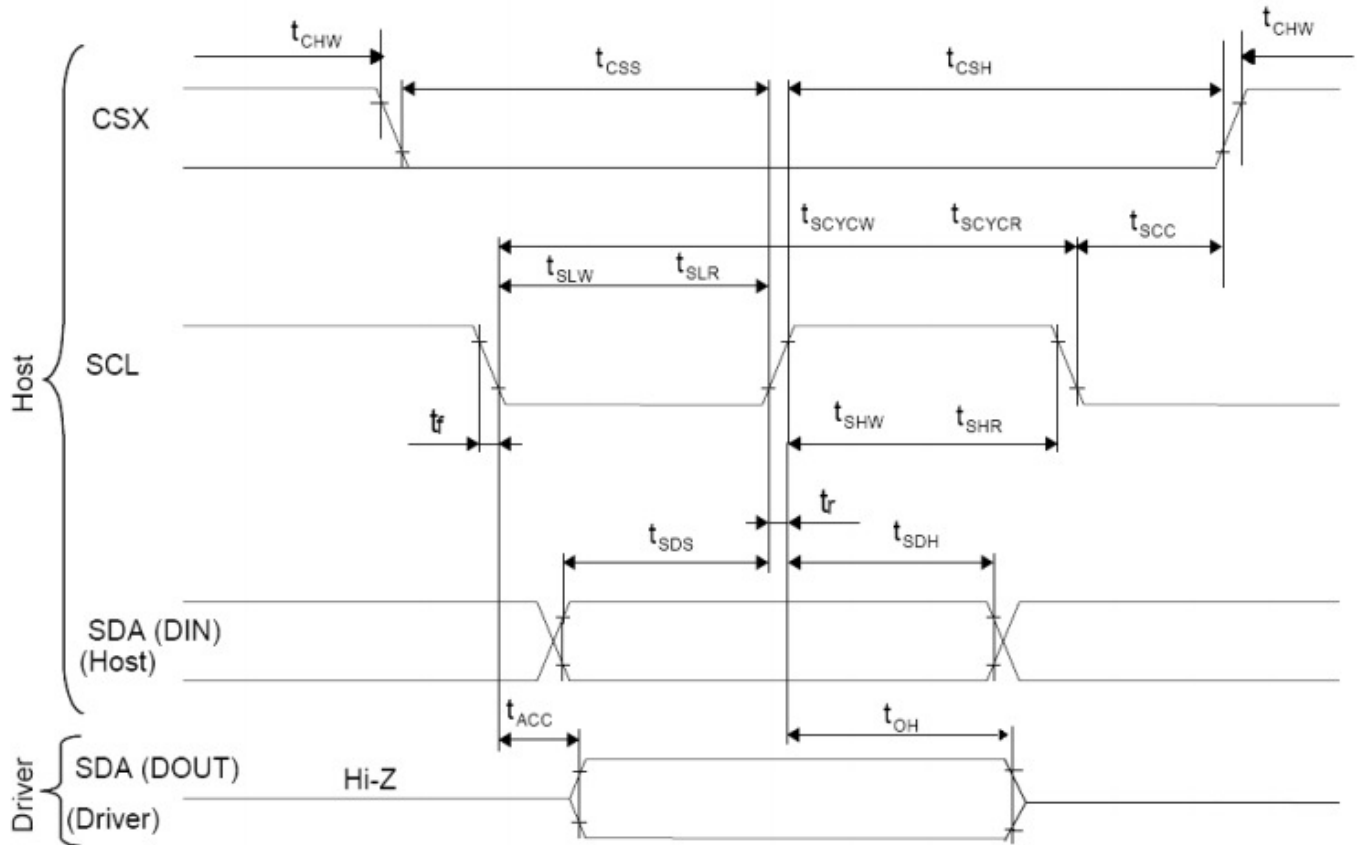

### 8.2 3 Wire-SPI Interface Input Timing parameters

Signal	Symbol	Parameter	min	max	Unit	Description
SCL	tscycw	Serial Clock Cycle (Write)	100	-	ns	
	tshw	SCL "H" Pulse Width (Write)	40	-	ns	
	tslw	SCL "L" Pulse Width (Write)	40	-	ns	
	tscycr	Serial Clock Cycle (Read)	150	-	ns	
	tshr	SCL "H" Pulse Width (Read)	60	-	ns	
	tslr	SCL "L" Pulse Width (Read)	60	-	ns	
SDA / SDI (Input)	tsds	Data setup time (Write)	30	-	ns	
	tsdh	Data hold time (Write)	30	-	ns	
SDA / SDO (Output)	tacc	Access time (Read)	10	-	ns	
	toh	Output disable time (Read)	10	50	ns	
CSX	tsc	SCL-CSX	20	-	ns	
	tchw	CSX "H" Pulse Width	40	-	ns	
	tcss	CSX-SCL Time	60	-	ns	
	tcs		65	-	ns	

Note:  $T_a = 25\text{ }^\circ\text{C}$ ,  $V_{DDI}=1.65\text{V to }3.3\text{V}$ ,  $V_{CI}=2.5\text{V to }3.3\text{V}$ ,  $AGND=V_{SS}=0\text{V}$

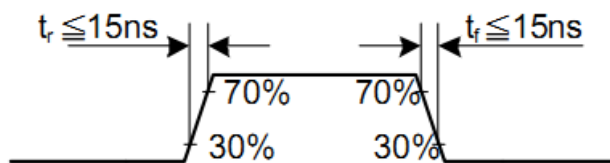

CPU Input Timing Parameters

### 8.3 Parallel 18/16/6-bit RGB Interface Timing Characteristics

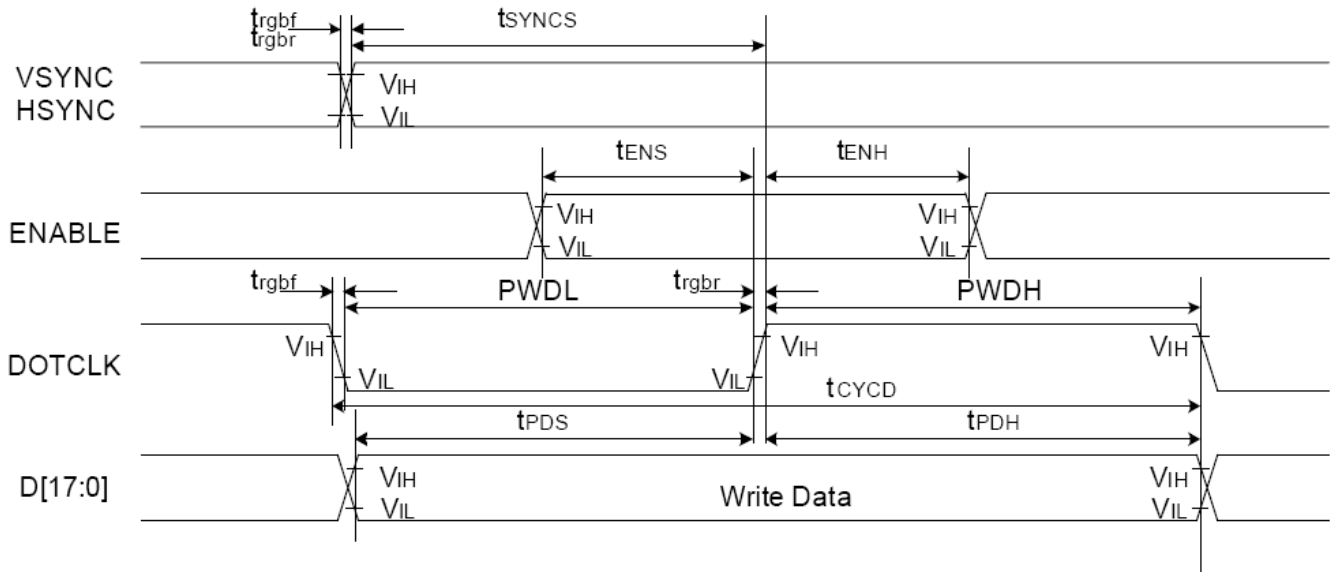

### 8.4 Parallel 18/16/6-bit RGB Interface Timing Parameters

Signal	Symbol	Parameter	min	max	Unit	Description
VSYNC / HSYNC	$t_{SYNCS}$	VSYNC/HSYNC setup time	15	-	ns	18/16-bit bus RGB interface mode
	$t_{SYNCH}$	VSYNC/HSYNC hold time	15	-	ns	
DE	$t_{ENS}$	DE setup time	15	-	ns	
	$t_{ENH}$	DE hold time	15	-	ns	
D[17:0]	$t_{POS}$	Data setup time	15	-	ns	
	$t_{PDH}$	Data hold time	15	-	ns	
DOTCLK	PWDH	DOTCLK high-level period	15	-	ns	
	PWDL	DOTCLK low-level period	15	-	ns	
	$t_{CYCD}$	DOTCLK cycle time	100	-	ns	
	$t_{rgbr}, t_{rgbf}$	DOTCLK,HSYNC,VSYNC rise/fall time	-	15	ns	
VSYNC / HSYNC	$t_{SYNCS}$	VSYNC/HSYNC setup time	15	-	ns	6-bit bus RGB interface mode
	$t_{SYNCH}$	VSYNC/HSYNC hold time	15	-	ns	
DE	$t_{ENS}$	DE setup time	15	-	ns	
	$t_{ENH}$	DE hold time	15	-	ns	
D[17:0]	$t_{POS}$	Data setup time	15	-	ns	
	$t_{PDH}$	Data hold time	15	-	ns	
DOTCLK	PWDH	DOTCLK high-level pulse period	15	-	ns	
	PWDL	DOTCLK low-level pulse period	15	-	ns	
	$t_{CYCD}$	DOTCLK cycle time	100	-	ns	
	$t_{rgbr}, t_{rgbf}$	DOTCLK,HSYNC,VSYNC rise/fall time	-	15	ns	

Note:  $T_a = -30$  to  $70$  °C,  $V_{DDI}=1.65V$  to  $3.3V$ ,  $V_{CI}=2.5V$  to  $3.3V$ ,  $AGND=VSS=0V$

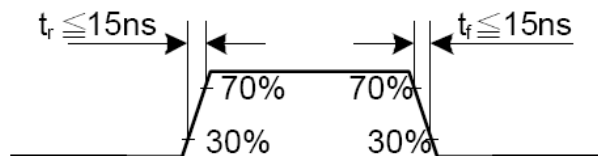

8.5 Reset Timing

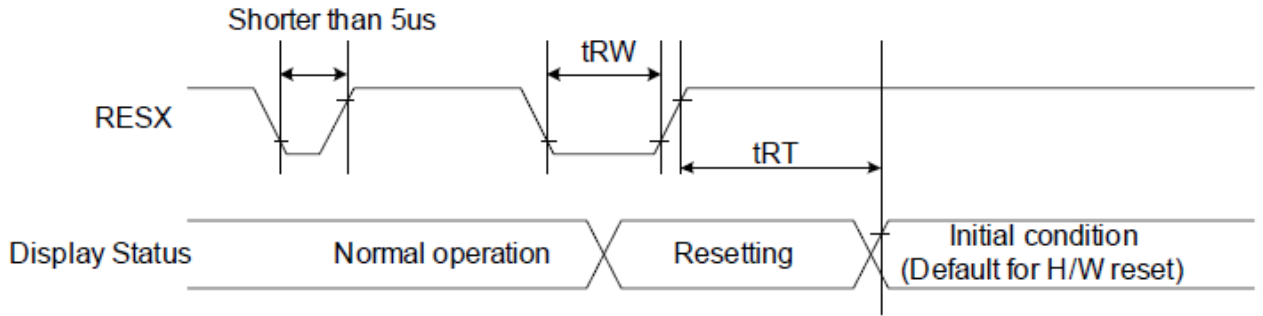

Signal	Symbol	Parameter	Min	Max	Unit
RESX	tRW	Reset pulse duration	10		uS
	tRT	Reset cancel		5 (note 1,5)	mS
				120 (note 1,6,7)	mS

8.6 Power ON/Off Sequence

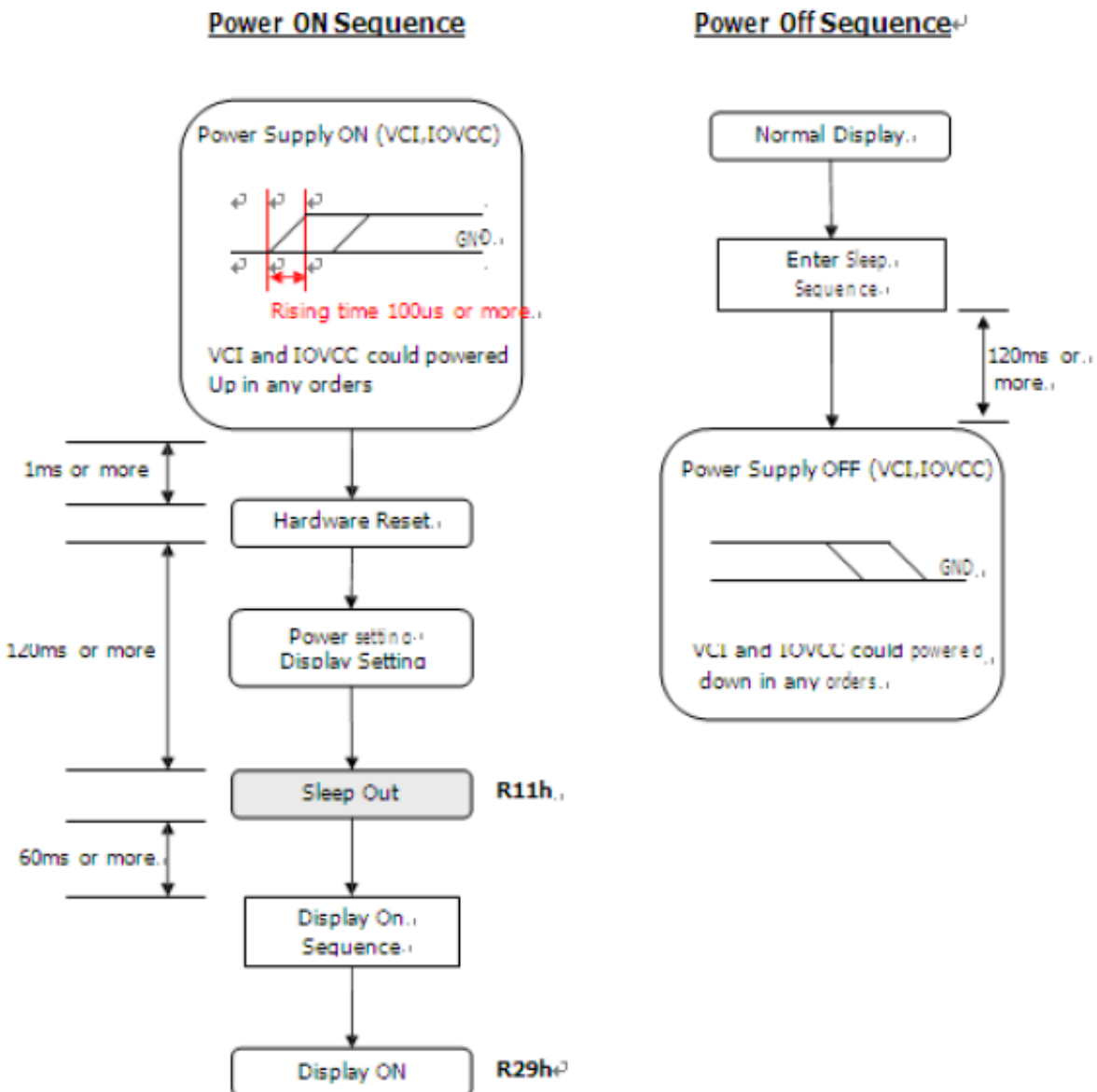

## 9. Optical Specification

### 9.1 Driving the backlight condition(Transmissivemode)

Item	Symbol	Condition	Min	Typ.	Max.	Unit	Remark
Contrast Ratio	CR	$\theta=0^\circ$	100	120	-		Note1 Note3
Response Time	Ton/ Toff	25°C	-	35	50	ms	Note1 Note4
View Angles	$\theta T$	$CR \geq 10$	38	48	-	Degree	Note 2
	$\theta B$		35	45	-		
	$\theta L$		30	40	-		
	$\theta R$		30	45	-		
Chromaticity	White	x	Brightness is on	0.273			Note5,
		y		0.296			
Luminance	L		80	90	-	cd/m <sup>2</sup>	Note6
Uniformity			70	80		%	Note8
NTSC			45	50		%	

### 9.2 Not Driving the backlight condition(Reflective mode)

Item	Symbol	Condition	Min	Typ.	Max.	Unit	Remark
Contrast Ratio	CR	$\theta=0^\circ$	7	10	-		Note1 Note3
Response Time	Ton/ Toff	25°C	-	35	40	ms	Note1 Note4
View Angles	$\theta T$	$CR \geq 10$	60	70	-	Degree	Note 2
	$\theta B$		60	70	-		
	$\theta L$		60	70	-		
	$\theta R$		60	70	-		
NTSC			5.5	7		%	
Reflectance	R		4.8	5.5	-	%	Note7

Note 1: Definition of optical measurement system.

Temperature = 25°C(±3°C)

LED back-light: ON, Environment brightness < 150 lx

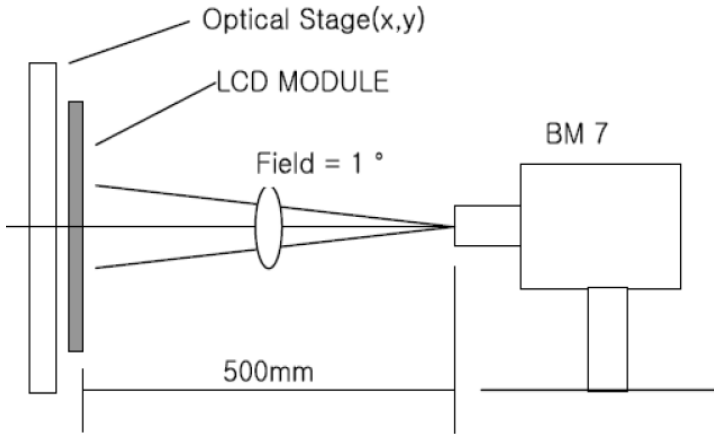

Note 2: Contrast ratio is defined as follow:

$$\text{Contrast Ratio} = \frac{\text{Surface Luminance with all white pixels}}{\text{Surface Luminance with all black pixels}}$$

Note 3: Response time is defined as follow:

Response time is the time required for the display to transition from black to white (Rise Time, Tr) and from white to black(Decay Time, Tf).

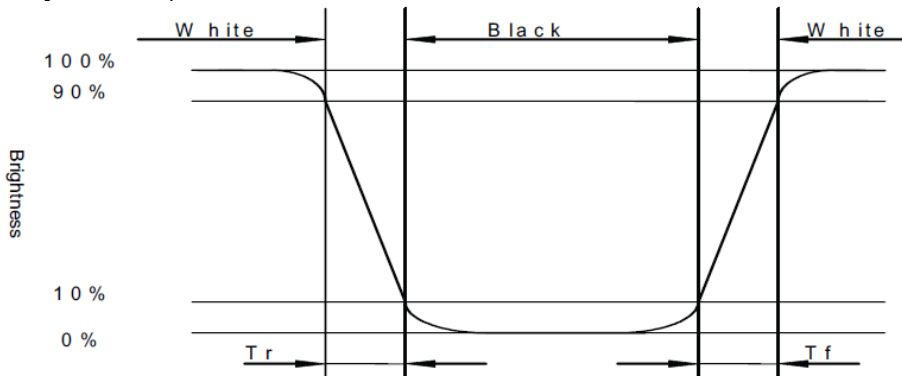

Note 4: Viewing angle range is defined as follow:

Viewing angle is measured at the center point of the LCD.

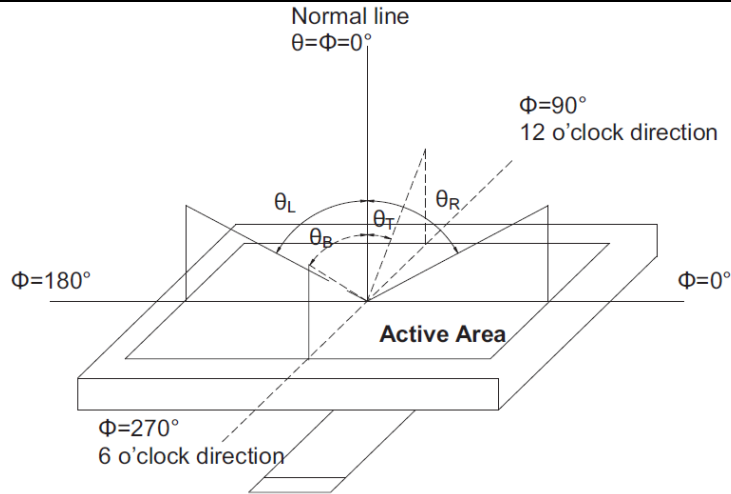

Note 5: Color chromaticity is defined as follow: (CIE1931)

Color coordinates measured at center point of LCD.

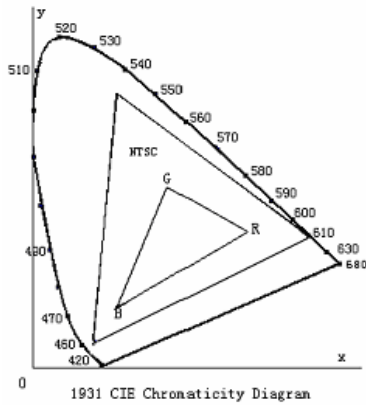

$$S = \frac{\text{area of RGB triangle}}{\text{area of NTSC triangle}} \times 100\%$$

Note 6: Luminance is defined as follow:

Luminance is defined as the brightness of all pixels “White” at the center of display area on optimum contrast.

Note 7: Reflectance measurement system is defined as follow:

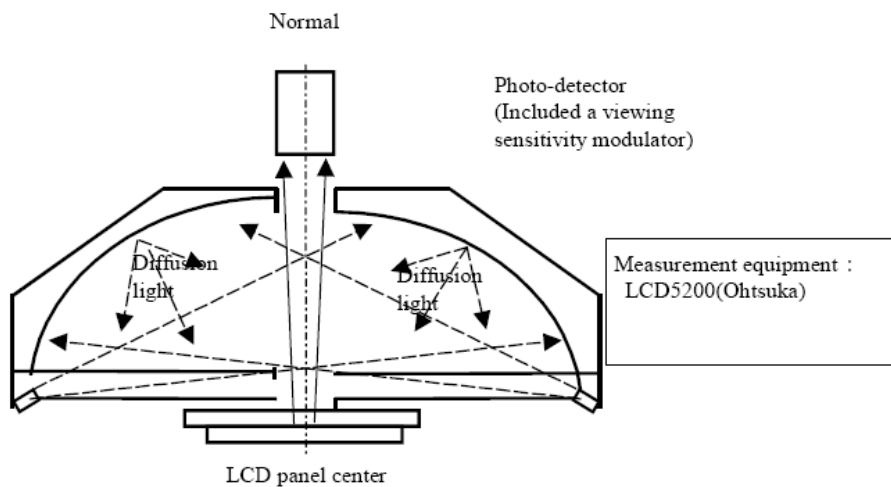

Note 8: Luminance Uniformity is defined as follow:

Active area is divided into 9 measuring areas (Refer Fig. 2). Every measuring point is placed at the center of each measuring area.

$$\text{Uniformity}(U) = \frac{\text{Minimum Luminance(brightness) in 9 points}}{\text{Maximum Luminance(brightness) in 9 points}}$$

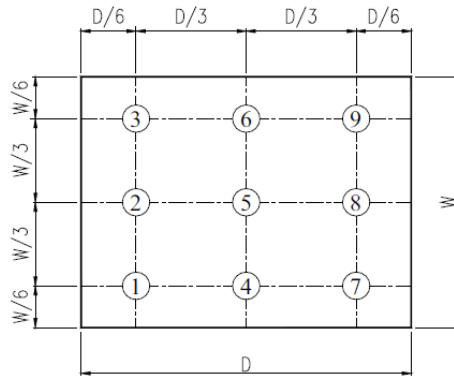

Fig. 2 Definition of uniformity

### 10. Environmental / Reliability Tests

No	Test Item	Condition	Judgment criteria
1	High Temp Operation	Ts=+70°C, 240hrs	Per table in below
2	Low Temp Operation	Ta=-20°C, 240hrs	Per table in below
3	High Temp Storage	Ta=+80°C, 240hrs	Per table in below
4	Low Temp Storage	Ta=-30°C, 240hrs	Per table in below
5	High Temp & High Humidity Storage	Ta=+40°C, 90% RH 240 hours	Per table in below (polarizer discoloration is excluded)
6	Thermal Shock (Non-operation)	-30°C 30 min~+80°C 30 min, Change time:5min, 10 Cycles	Per table in below
7	ESD (Operation)	C=150pF, R=330Ω 5points/panel Air:±8KV, 5times; Contact:±4KV, 5 times;	Per table in below
8	Vibration (Non-operation)	Frequency range:10~55Hz, Stroke:1.5mm Sweep:10Hz~55Hz~10Hz 2 hours for each direction of X.Y.Z.	Per table in below
9	Shock (Non-operation)	60G 6ms, ±X,±Y,±Z 3times, for each direction	Per table in below
10	Package Drop Test	Height:80 cm, 1 corner, 3 edges, 6 surfaces	Per table in below

INSPECTION	CRITERION(after test)
Appearance	No Crack on the FPC, on the LCD Panel
Alignment of LCD Panel	No Bubbles in the LCD Panel No other Defects of Alignment in Active area
Electrical current	Within device specifications
Function / Display	No Broken Circuit, No Short Circuit or No Black line No Other Defects of Display



## 11. Precautions for Use of LCD Modules

### 11.1 Safety

The liquid crystal in the LCD is poisonous. Do not put it in your mouth. If the liquid crystal touches your skin or clothes, wash it off immediately using soap and water.

### 11.2 Handling

- A. The LCD and touch panel is made of plate glass. Do not subject the panel to mechanical shock or to excessive force on its surface.
- B. Do not handle the product by holding the flexible pattern portion in order to assure the reliability
- C. Transparency is an important factor for the touch panel. Please wear clear finger sacks, gloves and mask to protect the touch panel from finger print or stain and also hold the portion outside the view area when handling the touch panel.
- D. Provide a space so that the panel does not come into contact with other components.
- E. To protect the product from external force, put a covering lens (acrylic board or similar board) and keep an appropriate gap between them.
- F. Transparent electrodes may be disconnected if the panel is used under environmental conditions where dew condensation occurs.
- G. Property of semiconductor devices may be affected when they are exposed to light, possibly resulting in IC malfunctions.
- H. To prevent such IC malfunctions, your design and mounting layout shall be done in the way that the IC is not exposed to light in actual use.

### 11.3 Static Electricity

- A. Ground soldering iron tips, tools and testers when they are in operation.
- B. Ground your body when handling the products.
- C. Power on the LCD module before applying the voltage to the input terminals.
- D. Do not apply voltage which exceeds the absolute maximum rating.
- E. Store the products in an anti-electrostatic bag or container.

### 11.4 Storage

- A. Store the products in a dark place at  $+25^{\circ}\text{C} \pm 10^{\circ}\text{C}$  with low humidity (40% RH to 60% RH). Don't expose to sunlight or fluorescent light.
- B. Storage in a clean environment, free from dust, active gas, and solvent.

### 11.5 Cleaning

- A. Do not wipe the touch panel with dry cloth, as it may cause scratch.
- B. Wipe off the stain on the product by using soft cloth moistened with ethanol. Do not allow ethanol to get in between the upper film and the bottom glass. It may cause peeling issue or defective operation. Do not use any organic solvent or detergent other than ethanol.

### 11.6 Cautions for installing and assembling

Bezel edge must be positioned in the area between the Active area and View area. The bezel may press the touch screen and cause activation if the edge touches the active area. A gap of approximately 0.5mm is needed between the bezel and the top electrode. It may cause unexpected activation if the gap is too narrow. There is a tolerance of 0.2 to 0.3mm for the outside dimensions of the touch panel and tail. A gap must be made to absorb the tolerance in the case and connector.

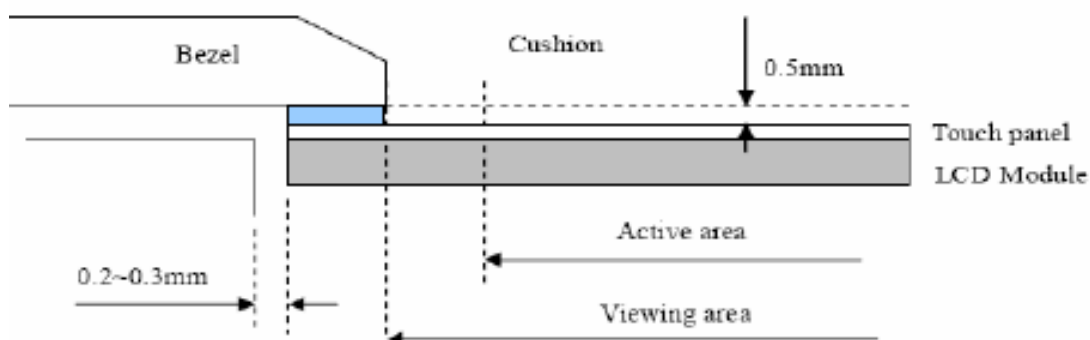

Компания «Life Electronics» занимается поставками электронных компонентов импортного и отечественного производства от производителей и со складов крупных дистрибьюторов Европы, Америки и Азии.

С конца 2013 года компания активно расширяет линейку поставок компонентов по направлению коаксиальный кабель, кварцевые генераторы и конденсаторы (керамические, пленочные, электролитические), за счёт заключения дистрибьюторских договоров

Мы предлагаем:

- Конкурентоспособные цены и скидки постоянным клиентам.
- Специальные условия для постоянных клиентов.
- Подбор аналогов.
- Поставку компонентов в любых объемах, удовлетворяющих вашим потребностям.
- Приемлемые сроки поставки, возможна ускоренная поставка.
- Доставку товара в любую точку России и стран СНГ.
- Комплексную поставку.
- Работу по проектам и поставку образцов.
- Формирование склада под заказчика.
- Сертификаты соответствия на поставляемую продукцию (по желанию клиента).
- Тестирование поставляемой продукции.
- Поставку компонентов, требующих военную и космическую приемку.
- Входной контроль качества.
- Наличие сертификата ISO.

В составе нашей компании организован Конструкторский отдел, призванный помогать разработчикам, и инженерам.

Конструкторский отдел помогает осуществить:

- Регистрацию проекта у производителя компонентов.
- Техническую поддержку проекта.
- Защиту от снятия компонента с производства.
- Оценку стоимости проекта по компонентам.
- Изготовление тестовой платы монтаж и пусконаладочные работы.



Тел: +7 (812) 336 43 04 (многоканальный)  
Email: [org@lifeelectronics.ru](mailto:org@lifeelectronics.ru)