



## SG901-1059B 802.11 b/g/n Wireless USB Module

### Overview

The SG901-1059B is a high speed module supporting all data rates of the latest standards including Wi-Fi 802.11B/G/N using a USB 2.0 interface. This module's high level of interoperability and its low cost is desirable for high volume applications. The product is suited for many embedded systems able to support Windows and Linux OS including high bandwidth applications such as set top box.

The SG901-1059B WLAN module is designed to operate in the 2.4GHz ISM frequency band. It utilizes a highly integrated MAC/BBP and RF single chip RT3070 design with 150Mbps PHY rate support. The module fully complies with IEEE802.11n draft 3.0 and IEEE802.11b/g feature sets.

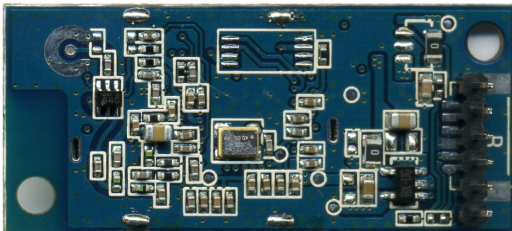

### Features

- 802.11b: 1, 2, 5.5, 11Mbps
- 802.11g: 6, 9, 12, 24, 36, 48, 54Mbps
- 802.11n:
  - (20MHz) MCS0-7, up to 72Mbps
  - (40MHz) MCS0-7, up to 150Mbps
- OFDM, Peak rate 150Mbps, 90Mbps peak throughput
- Security support for 64/128 WEP, WPA, WPA2, TKIP, AES
- Operates in the 2.4GHz frequency band.
- Low Power Consumption
- Single antenna configuration; I-PEX receptacle for external antenna.
- FCC Certified

### Applications

- Personal Digital Assistants (PDA)
- Hand-held Data Transfer Devices
- Video
- IP Cameras
- IP set top box
- GPS
- Internet radio apparatus

### Ordering Information

SG901-1059B-3.3-C (connector) – Bulk only  
SG901-1059B-5.0-C (connector) – Bulk only  
SG901-1059B-3.3-H (header) – Bulk only  
SG901-1059B-5.0-H (header) – Bulk only  
Eval Kit SG923-0012-3.3-C  
Eval Kit SG923-0012-3.3-H  
Eval Kit SG923-0012-5.0-H  
Eval Kit SG923-0012-5.0-C



## Block Diagram

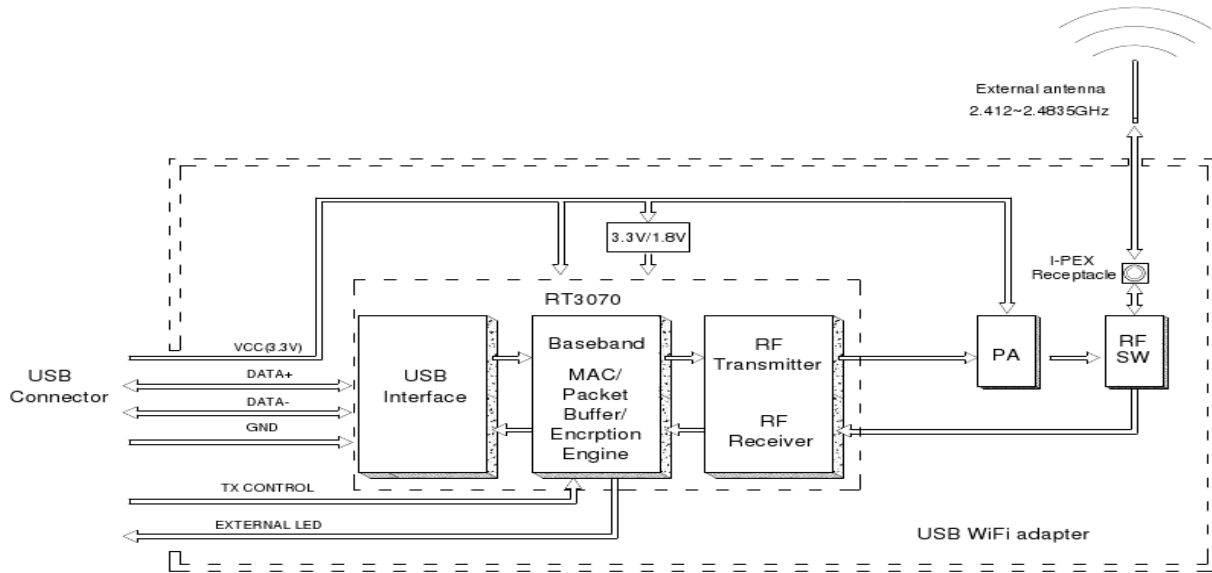

System Block Diagram of SG901-1059B-5.0 WLAN Module

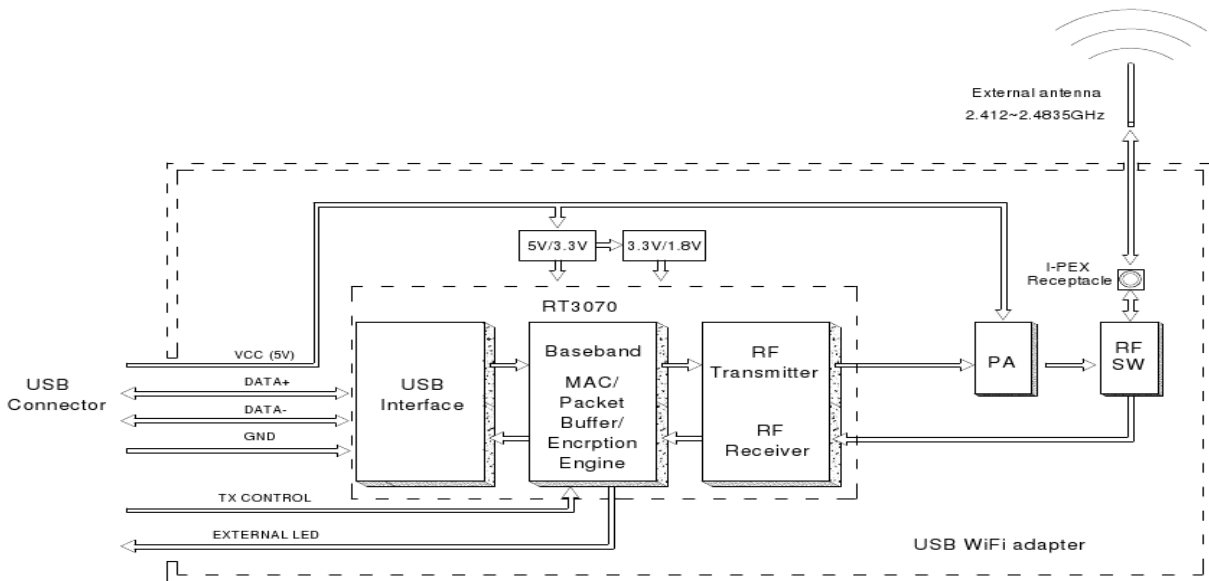

System Block Diagram of SG901-1059B-3.3 WLAN Module



## General Electrical Specifications

Parameter	Test Condition / Comment	Min.	Typ.	Max.	Units
Absolute Maximum Ratings					
USB Supply		-0.3		7	V
Operating Conditions and Input Power Specifications					
Operating Temperature Range	Normal Operating Range	-15		65	°C
	Storage Range	-20		85	°C
PC Interface			USB 2.0/1.1		
Plug & Play Compatible			YES		
Supply Voltage	SG901-1059B-5.0	4.75		5.2	V
	SG901-1059B-3.3	3.14	3.3	3.48	V

## RF Characteristics

Parameter	Test Condition / Comment	Min.	Typ.	Max.	Units
Internal Antenna Impedance			50		Ohms
RX Sensitivity	11b, 11Mbps		-85		dBm
	11g, 54Mbps		-70		dBm
	(HT20) 11n, MSC7		-66		dBm
	(HT40) 11n, MSC7		-62		dBm
TX Output Power	11b, 11Mbps	18	19	20	dBm
	11g, 54Mbps	14.5	16	17.5	dBm
	802.11n (HT20)	13.5	15	16.5	dBm
	802.11n (HT40)	13.5	15	16.5	dBm
TX Spectral MASK	CCK		PASS		
	OFDM		PASS		
	QPSK		PASS		
	BPSK		PASS		
Preamble Length			Long/Short		
Operating Current	3.3V supply, typical association			170	mA
	5V supply, typical association			110	mA

## Interface Details

Sagrad Part #	Supplier Part Number	Item	Comment
SG901-1066		Antenna	External Antenna via an I-PEX receptacle (IPEX 20279-001E-01)
SG901-1059B-xx-C	ACESCONN 87213-0600I	Host Interface Connector	6 Pin 1.0mm Pitch Connector.
SG901-1059B-xx-H		Host Interface Connector	6 Pin 2.0mm Male Header



## Connector Pin List (Host Interface)

### 6-pin 1.0mm pitch connector

SIGNAL NAME	PIN NUMBER	DESCRIPTION	NOTES
VCC (3.3 or 5.0 VDC)	1	Supply	USB Standard Function
UD-	2	Complementary USB Data	USB Standard Function
UD+	3	Complementary USB Data	USB Standard Function
GND	4	Ground	USB Standard Function
LED	5	Low Active for WLAN LED Link.	
TX	6	Low Voltage to disable RF function	

### 6-pin 2.0mm pitch male header

SIGNAL NAME	PIN NUMBER	DESCRIPTION	NOTES
VCC (3.3 or 5.0 VDC)	1	Supply	USB Standard Function
UD-	2	Complementary USB Data	USB Standard Function
UD+	3	Complementary USB Data	USB Standard Function
GND	4	Ground	USB Standard Function
TX	5	Low Voltage to disable RF function	
LED	6	Low Active for WLAN LED Link.	

## Software Information

### MIPS:

A 300-400 MIPS CPU can drive the SG901-1059B alone at its maximum performance level. If other network interfaces are being used in the device, more MIPS will be necessary.

### Source Code:

A device driver for the SG901-1059B is included in the Linux kernel under the name rt2800usb. For the very latest Linux driver, download the compat-wireless package from <http://linuxwireless.org/en/users/Download>

### Supported Systems:

The SG901-1059B has been tested on:  
x86 – Windows XP (32 bit only)  
x86 – Linux (32 and 64 bit)  
ARM – Linux 32 bit

### Security Support

Complete Security Features – WPA/WPA2, 64/128 WEP, TKIP, AES



## Mechanical Drawing

### 6-pin 1.0 mm pitch male connector – Top View

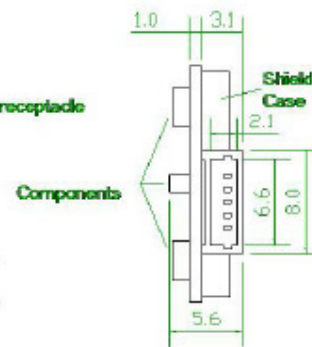
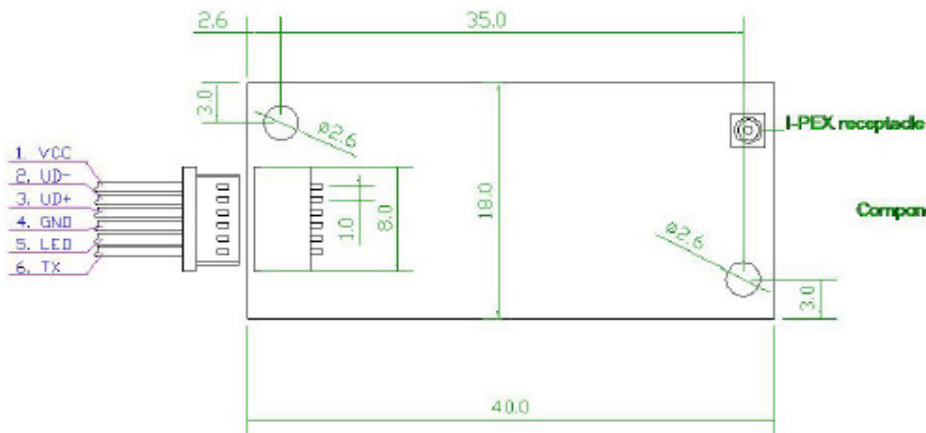
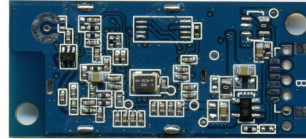

Unit: mm

### 6-pin 2.0 mm pitch male header – Top View

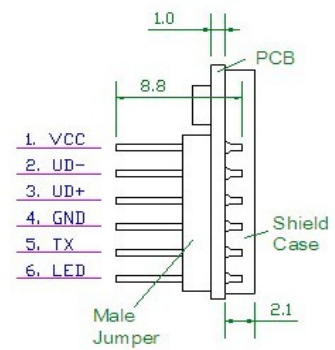
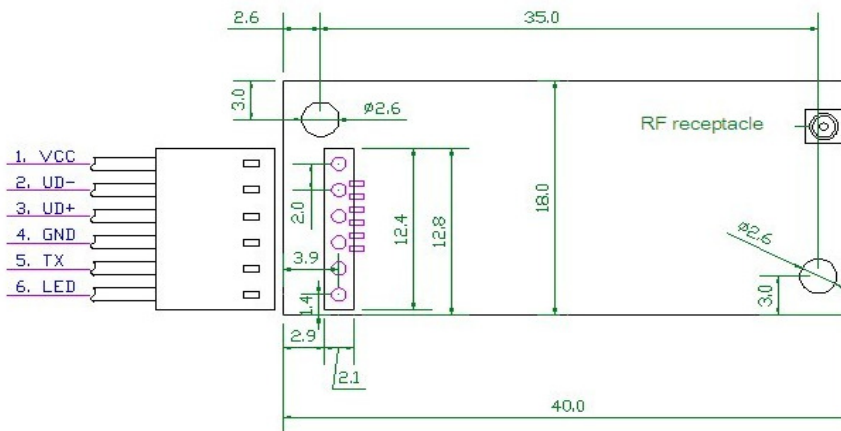
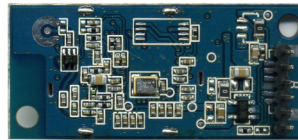

Unit: mm



For custom applications: the direction of the male header can be mounted upside down, please contact Sagrad Inc. for availability.

## Regulatory Approval

Agency	Approval
FCC Part 15	✓
CE	✓
RoHS	✓

## Suggested Antenna

- Sagrad part number SG901-1066



## Legal Notice

*The information in this publication has been carefully checked and is believed to be accurate at the time of publication. Sagrad assumes no responsibility, however, for possible errors or omissions, or for any consequences resulting from the use of the information contained herein.*

*Sagrad reserves the right to make changes, corrections, modifications, or improvements in its products or product specifications with the intent to improve function or design at any time and without notice and is not required to update this documentation to reflect such changes.*

*This publication does not convey to a purchaser of semiconductor devices described herein any license under the patent rights of Sagrad or others.*

*Purchasers are solely responsible for the choice, selection, and use of the Sagrad products and services described herein, and Sagrad assumes no liability whatsoever relating to the choice, selection, or use of the Sagrad products and services described herein.*

*"Typical" parameters can and do vary in different applications. All operating parameters, including "Typicals" must be validated for each customer application by the customer's technical experts.*

*Unless otherwise set forth in Sagrad's terms and conditions of sale, Sagrad makes no warranty, representation, or guarantee regarding the suitability, merchantability, or fitness of its products for any particular purpose, nor does Sagrad assume any liability arising out of the application or use of any product or circuit and specifically disclaims any and all liability, including without limitation any consequential or incidental damages.*

*Unless expressly approved in writing by two authorized Sagrad representatives, Sagrad products are not designed, intended, warranted, or authorized for use as components in military, space, or aircraft; in systems intended to support or sustain life; or for any other application in which the failure or malfunction of the Sagrad product may result in personal injury, death, or severe property or environmental damage.*

*Should the Buyer purchase or use a Sagrad product for any such unintended or unauthorized application, the Buyer shall indemnify and hold Sagrad and its officers, employees, subsidiaries, affiliates, and distributors harmless against all claims, costs, damages, expenses, and reasonable attorney fees arising out of, either directly or indirectly, any claim of damage, personal injury or death that may be associated with such unintended or unauthorized use, even if such claim alleges that Sagrad was negligent regarding the design or manufacture of said product.*

Компания «Life Electronics» занимается поставками электронных компонентов импортного и отечественного производства от производителей и со складов крупных дистрибьюторов Европы, Америки и Азии.

С конца 2013 года компания активно расширяет линейку поставок компонентов по направлению коаксиальный кабель, кварцевые генераторы и конденсаторы (керамические, пленочные, электролитические), за счёт заключения дистрибьюторских договоров

Мы предлагаем:

- Конкурентоспособные цены и скидки постоянным клиентам.
- Специальные условия для постоянных клиентов.
- Подбор аналогов.
- Поставку компонентов в любых объемах, удовлетворяющих вашим потребностям.
- Приемлемые сроки поставки, возможна ускоренная поставка.
- Доставку товара в любую точку России и стран СНГ.
- Комплексную поставку.
- Работу по проектам и поставку образцов.
- Формирование склада под заказчика.
- Сертификаты соответствия на поставляемую продукцию (по желанию клиента).
- Тестирование поставляемой продукции.
- Поставку компонентов, требующих военную и космическую приемку.
- Входной контроль качества.
- Наличие сертификата ISO.

В составе нашей компании организован Конструкторский отдел, призванный помогать разработчикам, и инженерам.

Конструкторский отдел помогает осуществить:

- Регистрацию проекта у производителя компонентов.
- Техническую поддержку проекта.
- Защиту от снятия компонента с производства.
- Оценку стоимости проекта по компонентам.
- Изготовление тестовой платы монтаж и пусконаладочные работы.



Тел: +7 (812) 336 43 04 (многоканальный)

Email: [org@lifeelectronics.ru](mailto:org@lifeelectronics.ru)