

**APT40DQ120BG**  
**Datasheet**  
**Ultrafast Soft Recovery Rectifier Diode**

Final  
March 2018



## Contents

---

<b>1</b>	<b>Revision History</b>	<b>1</b>
1.1	Revision D	1
1.2	Revision C	1
1.3	Revision B	1
1.4	Revision A	1
<b>2</b>	<b>Product Overview</b>	<b>2</b>
2.1	Features	2
2.2	Benefits	2
2.3	Applications	2
<b>3</b>	<b>Electrical Specifications</b>	<b>3</b>
3.1	Absolute Maximum Ratings	3
3.2	Electrical Performance	3
3.3	Dynamic Characteristics	4
3.4	Typical Performance Curves	5
3.5	Reverse Recovery Overview	7
<b>4</b>	<b>Package Specification</b>	<b>8</b>
4.1	Package Outline Drawing	8

# 1 Revision History

---

The revision history describes the changes that were implemented in the document. The changes are listed by revision, starting with the most current publication.

## 1.1 Revision D

Revision D was published in March 2018. The following is a summary of the changes in revision D of this document.

- The new Microsemi template and format was applied.
- The package outline drawing was updated. For more information, see [Package Outline Drawing](#).

## 1.2 Revision C

Revision C was published in May 2011. The following is a summary of the changes in revision C of this document.

- The patent information was removed from the document.
- For TO-247 packages: the maximum lead thickness was changed from 0.70 in (0.031 mm) to 1.016 in (0.040 mm).

## 1.3 Revision B

Revision B was published in August 2005. The following is a summary of the changes in revision B of this document.

- The  $I_{RM}$  in the static characteristics table was updated. For more information, see [Electrical Performance](#).

## 1.4 Revision A

Revision A was published in May 2005. It is the first publication of this document.

## 2 Product Overview

---

This section outlines the product overview for the APT40DQ120BG device.

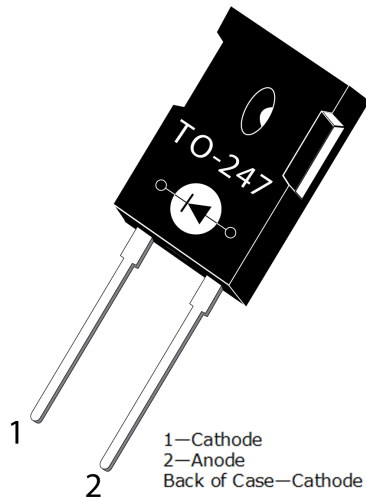

### 2.1 Features

The following are key features of the APT40DQ120BG device:

- Ultrafast recovery times
- Soft recovery characteristics
- Low forward voltage
- Low leakage current
- Avalanche energy rated
- RoHS compliant
- AEC-Q101 qualified

### 2.2 Benefits

The following are benefits of the APT40DQ120BG device:

- Higher switching frequency
- Low switching losses
- Low noise (EMI) switching
- Higher reliability systems
- Increased system power density

### 2.3 Applications

The APT40DQ120BG device is designed for the following applications:

- Power factor correction (PFC)
- Anti-parallel diode
  - Switch-mode power supply
  - Inverters/converters
  - Motor controllers
- Freewheeling diode
  - Switch-mode power supply
  - Inverters/converters
- Snubber/clamp diode

### 3 Electrical Specifications

This section shows the electrical specifications for the APT40DQ120BG device.

#### 3.1 Absolute Maximum Ratings

The following table shows the absolute maximum ratings for the APT40DQ120BG device.

All ratings:  $T_c = 25\text{ }^\circ\text{C}$  unless otherwise specified.

**Table 1 • Absolute Maximum Ratings**

Symbol	Parameter	Ratings	Unit
$V_R$	Maximum DC reverse voltage	1200	V
$V_{RRM}$	Maximum peak repetitive reverse voltage	1200	
$V_{RWM}$	Maximum working peak reverse voltage	1200	
$I_{F(AV)}$	Maximum average forward current ( $T_c = 112\text{ }^\circ\text{C}$ , duty cycle = 0.5)	40	A
$I_{F(RMS)}$	RMS forward current	63	
$I_{FSM}$	Non-repetitive forward surge current ( $T_j = 45\text{ }^\circ\text{C}$ , 8.3 ms)	210	
$E_{AVL}$	Avalanche energy (1 A, 40 mH)	20	mJ
$T_j, T_{STG}$	Operating and storage temperature range	-55 to 175	$^\circ\text{C}$
$T_L$	Lead temperature for 10 seconds	300	

The following table shows the thermal and mechanical characteristics of the APT40DQ120BG device.

**Table 2 • Thermal and Mechanical Characteristics**

Symbol	Characteristic	Min	Typ	Max	Unit
$R_{\theta JC}$	Junction-to-case thermal resistance			0.61	$^\circ\text{C}/\text{W}$
$W_T$	Package weight		0.22		oz
			5.9		g
Torque	Maximum mounting torque			10	lb-in
				1.1	N-m

#### 3.2 Electrical Performance

The following table shows the static characteristics of the APT40DQ120BG device.

**Table 3 • Static Characteristics**

Symbol	Characteristic	Test Conditions	Min	Typ	Max	Unit
$V_F$	Forward voltage	$I_F = 30\text{ A}$		2.8	3.3	V
		$I_F = 60\text{ A}$		3.4		
		$I_F = 30\text{ A}, T_j = 125\text{ }^\circ\text{C}$		2.1		
$I_{RM}$	Maximum reverse leakage current	$V_R = 1200\text{ V}$			100	$\mu\text{A}$
		$V_R = 1200\text{ V}, T_j = 125\text{ }^\circ\text{C}$			500	
$C_j$	Junction capacitance	$V_R = 200\text{ V}$		36		pF

### 3.3 Dynamic Characteristics

The following table shows the dynamic characteristics of the APT40DQ120BG device.

**Table 4 • Dynamic Characteristics**

Symbol	Characteristic	Test Conditions	Min	Typ	Max	Unit
$t_{rr}$	Reverse recovery time	$I_F = 1\text{ A}$ $di_F/dt = -100\text{ A}/\mu\text{s}$ $V_R = 30\text{ V}$ $T_J = 25\text{ }^\circ\text{C}$		26		ns
$t_{rr}$	Reverse recovery time	$I_F = 40\text{ A}$		350		
$Q_{rr}$	Reverse recovery charge	$di_F/dt = -200\text{ A}/\mu\text{s}$ $V_R = 800\text{ V}$		570		nC
$I_{RRM}$	Maximum reverse recovery current	$T_C = 25\text{ }^\circ\text{C}$		4		A
$t_{rr}$	Reverse recovery time	$I_F = 40\text{ A}$		430		ns
$Q_{rr}$	Reverse recovery charge	$di_F/dt = -200\text{ A}/\mu\text{s}$ $V_R = 800\text{ V}$		2200		nC
$I_{RRM}$	Maximum reverse recovery current	$T_C = 125\text{ }^\circ\text{C}$		9		A
$t_{rr}$	Reverse recovery time	$I_F = 40\text{ A}$		210		ns
$Q_{rr}$	Reverse recovery charge	$di_F/dt = -1000\text{ A}/\mu\text{s}$ $V_R = 800\text{ V}$		3400		nC
$I_{RRM}$	Maximum reverse recovery current	$T_C = 125\text{ }^\circ\text{C}$		29		A

### 3.4 Typical Performance Curves

This section shows the typical performance curves for the APT40DQ120BG device.

**Figure 1 • Maximum Transient Thermal Impedance**

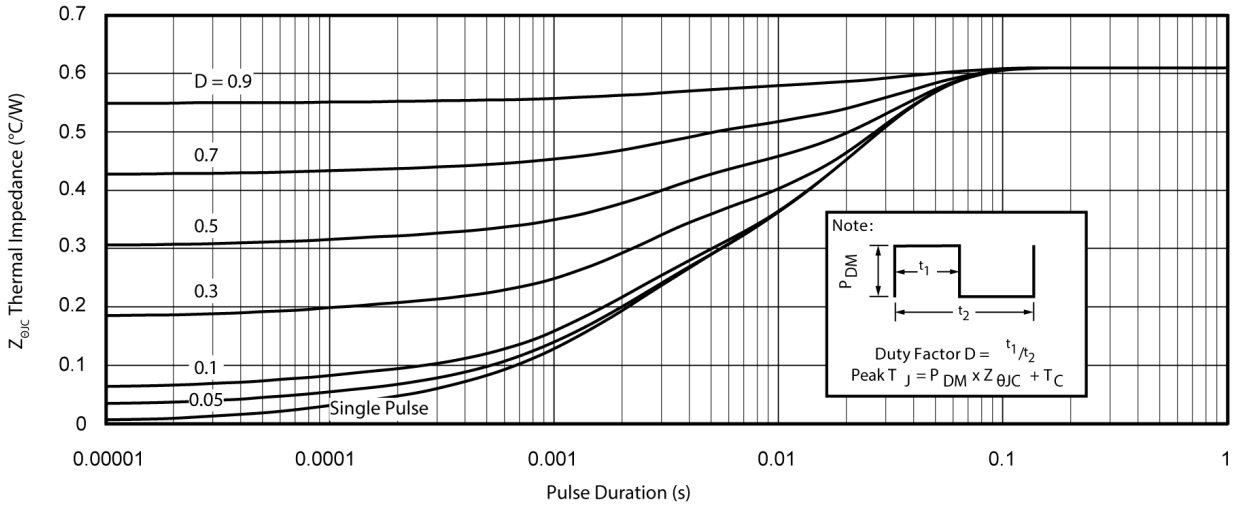

**Figure 2 • Forward Current vs. Forward Voltage**

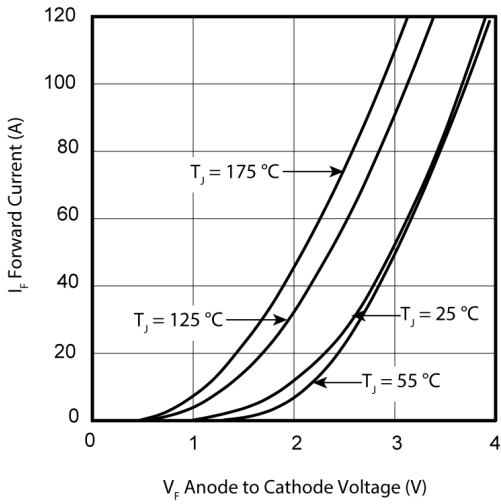

**Figure 3 •  $t_{rr}$  vs. Current Rate of Change**

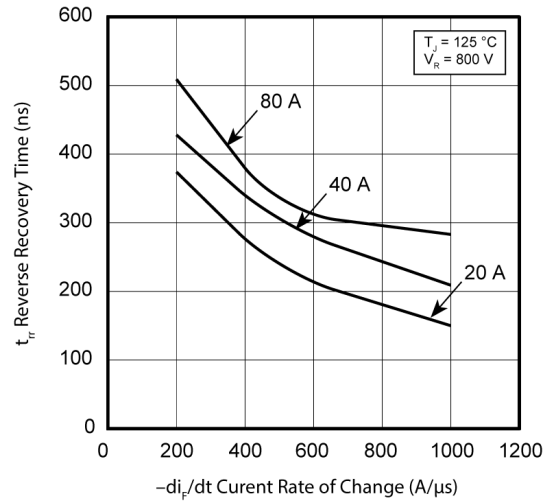

**Figure 4 • Q<sub>rr</sub> vs. Current Rate of Change**

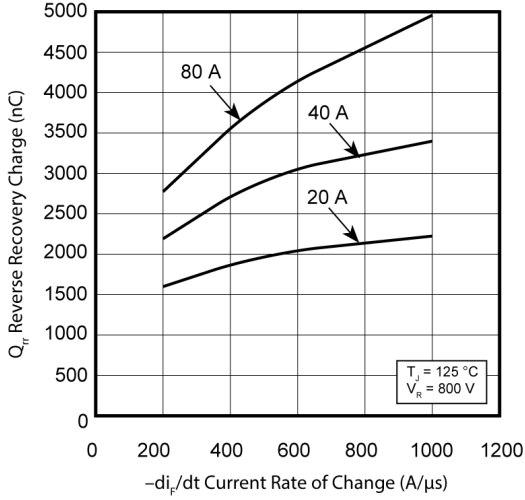

**Figure 5 • I<sub>RRM</sub> vs. Current Rate of Change**

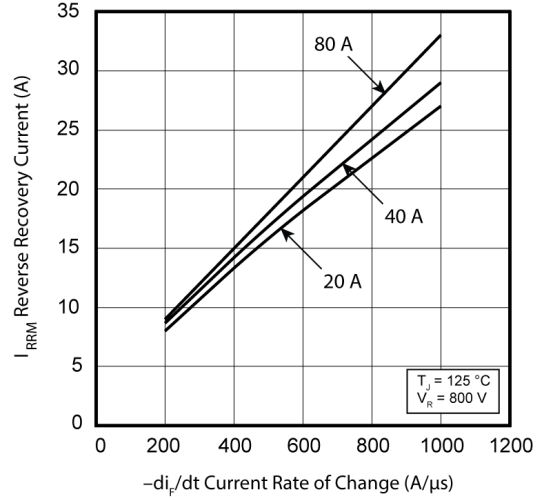

**Figure 6 • K<sub>f</sub> vs. Junction Temperature**

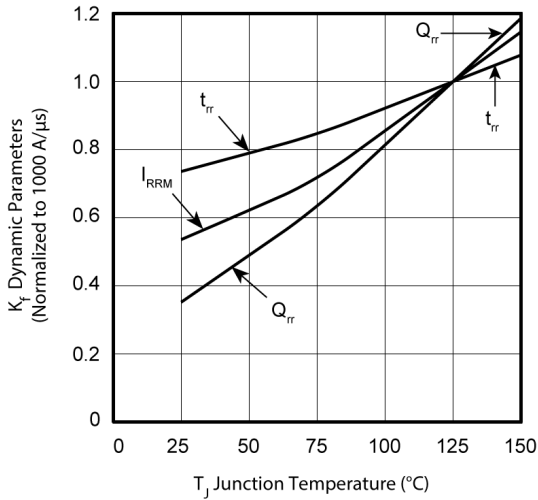

**Figure 7 • I<sub>F(AV)</sub> vs. Case Temperature**

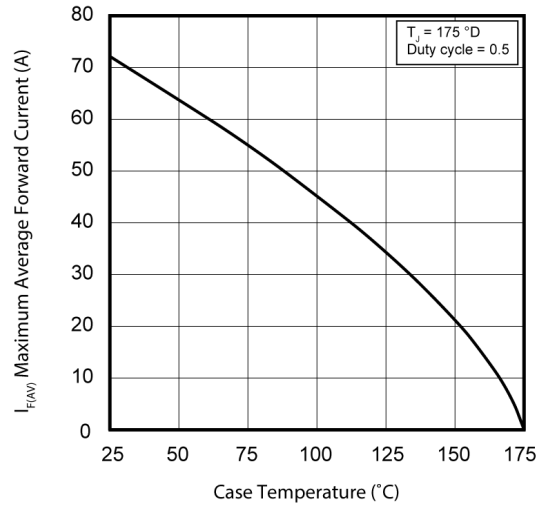

**Figure 8 • Junction Capacitance vs. Reverse Voltage**

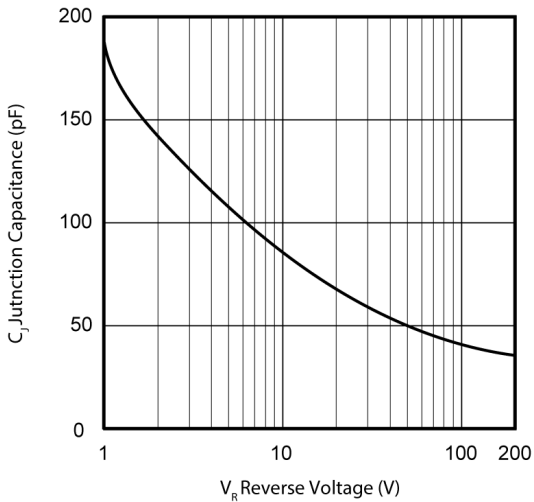



### 3.5 Reverse Recovery Overview

The following illustration shows the diode test circuit for the APT40DQ120BG device.

Figure 9 • Diode Test Circuit

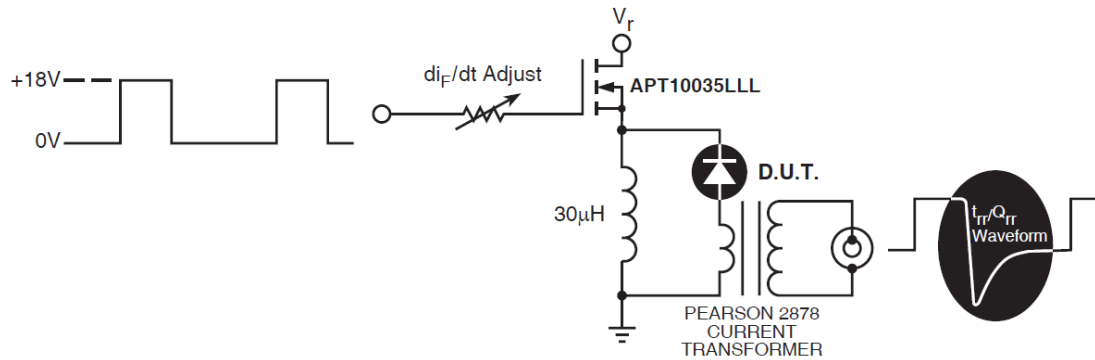

The following illustration shows the diode reverse recovery waveform and definitions for the APT40DQ120BG device.

Figure 10 • Diode Reverse Recovery Waveform and Definitions

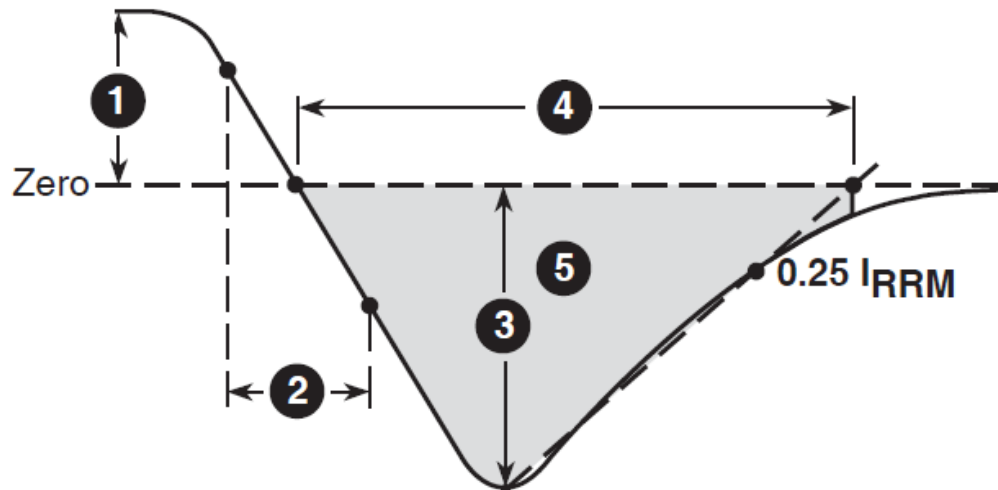

1.  $I_F$ —Forward conduction current.
2.  $di_F/dt$ —Rate of diode current change through zero crossing.
3.  $I_{RRM}$ —Maximum reverse recovery current.
4.  $t_{rr}$ —Reverse recovery time, measured from zero crossing where diode current goes from positive to negative, to the point at which the straight line through  $I_{RRM}$  and  $0.25 \cdot I_{RRM}$  passes through zero.
5.  $Q_{rr}$ —Area under the curve defined by  $I_{RRM}$  and  $t_{rr}$ .

## 4 Package Specification

This section shows the package specification for the APT40DQ120BG device.

### 4.1 Package Outline Drawing

This section shows the TO-247 package drawing of the APT40DQ120BG device. Dimensions are in millimeters and (inches).

Figure 11 • Package Outline Drawing

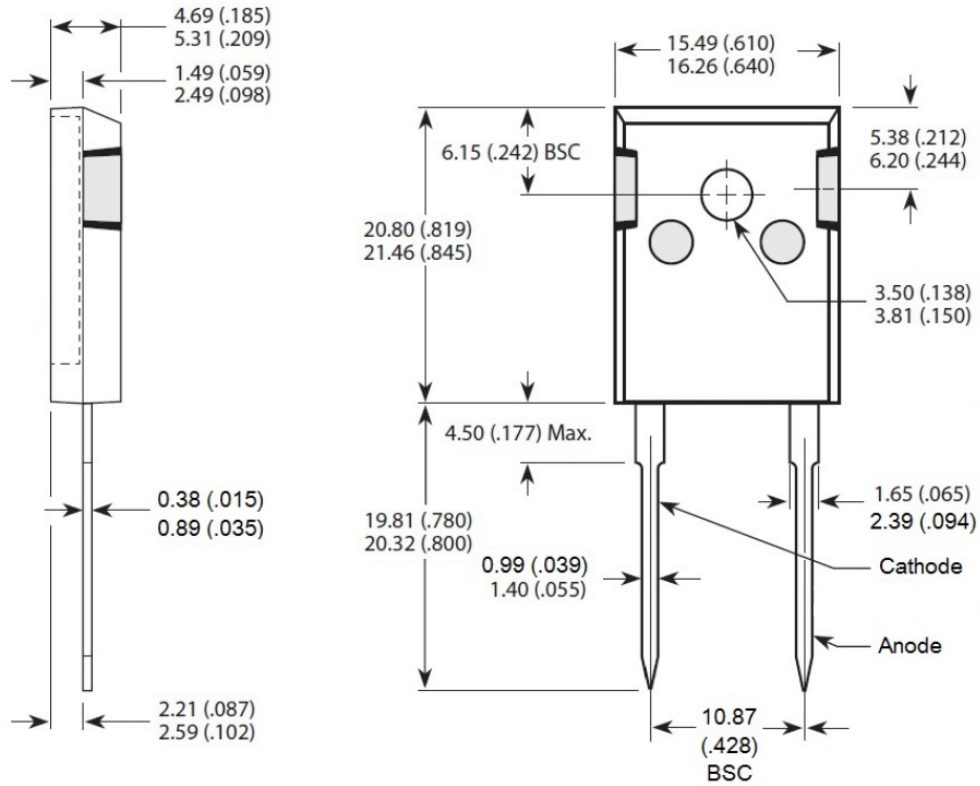

**Microsemi Corporate Headquarters**

One Enterprise, Aliso Viejo,  
CA 92656 USA  
Within the USA: +1 (800) 713-4113  
Outside the USA: +1 (949) 380-6100  
Fax: +1 (949) 215-4996  
Email: [sales.support@microsemi.com](mailto:sales.support@microsemi.com)  
[www.microsemi.com](http://www.microsemi.com)

© 2018 Microsemi Corporation. All rights reserved. Microsemi and the Microsemi logo are trademarks of Microsemi Corporation. All other trademarks and service marks are the property of their respective owners.

Microsemi makes no warranty, representation, or guarantee regarding the information contained herein or the suitability of its products and services for any particular purpose, nor does Microsemi assume any liability whatsoever arising out of the application or use of any product or circuit. The products sold hereunder and any other products sold by Microsemi have been subject to limited testing and should not be used in conjunction with mission-critical equipment or applications. Any performance specifications are believed to be reliable but are not verified, and Buyer must conduct and complete all performance and other testing of the products, alone and together with, or installed in, any end-products. Buyer shall not rely on any data and performance specifications or parameters provided by Microsemi. It is the Buyer's responsibility to independently determine suitability of any products and to test and verify the same. The information provided by Microsemi hereunder is provided "as is, where is" and with all faults, and the entire risk associated with such information is entirely with the Buyer. Microsemi does not grant, explicitly or implicitly, to any party any patent rights, licenses, or any other IP rights, whether with regard to such information itself or anything described by such information. Information provided in this document is proprietary to Microsemi, and Microsemi reserves the right to make any changes to the information in this document or to any products and services at any time without notice.

Microsemi Corporation (Nasdaq: MSCC) offers a comprehensive portfolio of semiconductor and system solutions for aerospace & defense, communications, data center and industrial markets. Products include high-performance and radiation-hardened analog mixed-signal integrated circuits, FPGAs, SoCs and ASICs; power management products; timing and synchronization devices and precise time solutions, setting the world's standard for time; voice processing devices; RF solutions; discrete components; enterprise storage and communication solutions; security technologies and scalable anti-tamper products; Ethernet solutions; Power-over-Ethernet ICs and midspans; as well as custom design capabilities and services. Microsemi is headquartered in Aliso Viejo, California, and has approximately 4,800 employees globally. Learn more at [www.microsemi.com](http://www.microsemi.com).

053-4217

Компания «Life Electronics» занимается поставками электронных компонентов импортного и отечественного производства от производителей и со складов крупных дистрибьюторов Европы, Америки и Азии.

С конца 2013 года компания активно расширяет линейку поставок компонентов по направлению коаксиальный кабель, кварцевые генераторы и конденсаторы (керамические, пленочные, электролитические), за счёт заключения дистрибьюторских договоров

Мы предлагаем:

- Конкурентоспособные цены и скидки постоянным клиентам.
- Специальные условия для постоянных клиентов.
- Подбор аналогов.
- Поставку компонентов в любых объемах, удовлетворяющих вашим потребностям.
- Приемлемые сроки поставки, возможна ускоренная поставка.
- Доставку товара в любую точку России и стран СНГ.
- Комплексную поставку.
- Работу по проектам и поставку образцов.
- Формирование склада под заказчика.
- Сертификаты соответствия на поставляемую продукцию (по желанию клиента).
- Тестирование поставляемой продукции.
- Поставку компонентов, требующих военную и космическую приемку.
- Входной контроль качества.
- Наличие сертификата ISO.

В составе нашей компании организован Конструкторский отдел, призванный помогать разработчикам, и инженерам.

Конструкторский отдел помогает осуществить:

- Регистрацию проекта у производителя компонентов.
- Техническую поддержку проекта.
- Защиту от снятия компонента с производства.
- Оценку стоимости проекта по компонентам.
- Изготовление тестовой платы монтаж и пусконаладочные работы.



Тел: +7 (812) 336 43 04 (многоканальный)

Email: [org@lifeelectronics.ru](mailto:org@lifeelectronics.ru)