



LPC11U2x

32-bit ARM Cortex-M0 microcontroller; up to 32 kB flash; up to 10 kB SRAM and 4 kB EEPROM; USB device; USART

Rev. 2.3 — 27 March 2014

Product data sheet

1. General description

The LPC11U2x are an ARM Cortex-M0 based, low-cost 32-bit MCU family, designed for 8/16-bit microcontroller applications, offering performance, low power, simple instruction set and memory addressing together with reduced code size compared to existing 8/16-bit architectures.

The LPC11U2x operate at CPU frequencies of up to 50 MHz.

Equipped with a highly flexible and configurable Full-Speed USB 2.0 device controller, the LPC11U2x brings unparalleled design flexibility and seamless integration to today's demanding connectivity solutions.

The peripheral complement of the LPC11U2x includes up to 32 kB of flash memory, up to 10 kB of SRAM data memory and 4 kB EEPROM, one Fast-mode Plus I²C-bus interface, one RS-485/EIA-485 USART with support for synchronous mode and smart card interface, two SSP interfaces, four general-purpose counter/timers, a 10-bit ADC (Analog-to-Digital Converter), and up to 54 general-purpose I/O pins.

For additional documentation related to the LPC11U2x parts, see [Section 15 "References"](#).

2. Features and benefits

- System:
 - ◆ ARM Cortex-M0 processor, running at frequencies of up to 50 MHz.
 - ◆ ARM Cortex-M0 built-in Nested Vectored Interrupt Controller (NVIC).
 - ◆ Non-Maskable Interrupt (NMI) input selectable from several input sources.
 - ◆ System tick timer.
- Memory:
 - ◆ Up to 32 kB on-chip flash program memory.
 - ◆ Up to 4 kB on-chip EEPROM data memory; byte erasable and byte programmable.
 - ◆ Up to 10 kB SRAM data memory.
 - ◆ 16 kB boot ROM.
 - ◆ In-System Programming (ISP) and In-Application Programming (IAP) for flash and EEPROM via on-chip bootloader software.
 - ◆ ROM-based USB drivers. Flash updates via USB supported.
 - ◆ ROM-based 32-bit integer division routines.
- Debug options:



- ◆ Standard JTAG (Joint Test Action Group) test interface for BSDL (Boundary Scan Description Language).
- ◆ Serial Wire Debug.
- Digital peripherals:
 - ◆ Up to 54 General-Purpose I/O (GPIO) pins with configurable pull-up/pull-down resistors, repeater mode, and open-drain mode.
 - ◆ Up to 8 GPIO pins can be selected as edge and level sensitive interrupt sources.
 - ◆ Two GPIO grouped interrupt modules enable an interrupt based on a programmable pattern of input states of a group of GPIO pins.
 - ◆ High-current source output driver (20 mA) on one pin.
 - ◆ High-current sink driver (20 mA) on true open-drain pins.
 - ◆ Four general-purpose counter/timers with a total of up to 5 capture inputs and 13 match outputs.
 - ◆ Programmable Windowed WatchDog Timer (WWDT) with a dedicated, internal low-power WatchDog Oscillator (WDO).
- Analog peripherals:
 - ◆ 10-bit ADC with input multiplexing among eight pins.
- Serial interfaces:
 - ◆ USB 2.0 full-speed device controller.
 - ◆ USART (Universal Synchronous Asynchronous Receiver/Transmitter) with fractional baud rate generation, internal FIFO, a full modem control handshake interface, and support for RS-485/9-bit mode and synchronous mode. USART supports an asynchronous smart card interface (ISO 7816-3).
 - ◆ Two SSP (Synchronous Serial Port) controllers with FIFO and multi-protocol capabilities.
 - ◆ I²C-bus interface supporting the full I²C-bus specification and Fast-mode Plus with a data rate of up to 1 Mbit/s with multiple address recognition and monitor mode.
- Clock generation:
 - ◆ Crystal Oscillator with an operating range of 1 MHz to 25 MHz (system oscillator).
 - ◆ 12 MHz high-frequency Internal RC oscillator (IRC) that can optionally be used as a system clock.
 - ◆ Internal low-power, low-frequency WatchDog Oscillator (WDO) with programmable frequency output.
 - ◆ PLL allows CPU operation up to the maximum CPU rate with the system oscillator or the IRC as clock sources.
 - ◆ A second, dedicated PLL is provided for USB.
 - ◆ Clock output function with divider that can reflect the crystal oscillator, the main clock, the IRC, or the watchdog oscillator.
- Power control:
 - ◆ Integrated PMU (Power Management Unit) to minimize power consumption during Sleep, Deep-sleep, Power-down, and Deep power-down modes.
 - ◆ Power profiles residing in boot ROM provide optimized performance and minimized power consumption for any given application through one simple function call.
 - ◆ Four reduced power modes: Sleep, Deep-sleep, Power-down, and Deep power-down.
 - ◆ Processor wake-up from Deep-sleep and Power-down modes via reset, selectable GPIO pins, watchdog interrupt, or USB port activity.

- ◆ Processor wake-up from Deep power-down mode using one special function pin.
- ◆ Power-On Reset (POR).
- ◆ Brownout detect with four separate thresholds for interrupt and forced reset.
- Unique device serial number for identification.
- Single 3.3 V power supply (1.8 V to 3.6 V).
- Temperature range -40 °C to +85 °C.
- Available as LQFP64, LQFP48, TFBGA48, and HVQFN33 packages.

3. Applications

- Consumer peripherals
- Medical
- Industrial control
- Handheld scanners
- USB audio devices

4. Ordering information

Table 1. Ordering information

Type number	Package		
	Name	Description	Version
LPC11U22FBD48/301	LQFP48	plastic low profile quad flat package; 48 leads; body 7 × 7 × 1.4 mm	SOT313-2
LPC11U23FBD48/301	LQFP48	plastic low profile quad flat package; 48 leads; body 7 × 7 × 1.4 mm	SOT313-2
LPC11U24FHI33/301	HVQFN33	plastic thermal enhanced very thin quad flat package; no leads; 33 terminals; body 5 × 5 × 0.85 mm	n/a
LPC11U24FBD48/301	LQFP48	plastic low profile quad flat package; 48 leads; body 7 × 7 × 1.4 mm	SOT313-2
LPC11U24FET48/301	TFBGA48	plastic thin fine-pitch ball grid array package; 48 balls; body 4.5 × 4.5 × 0.7 mm	SOT1155-2
LPC11U24FHN33/401	HVQFN33	plastic thermal enhanced very thin quad flat package; no leads; 33 terminals; body 7 × 7 × 0.85 mm	n/a
LPC11U24FBD48/401	LQFP48	plastic low profile quad flat package; 48 leads; body 7 × 7 × 1.4 mm	SOT313-2
LPC11U24FBD64/401	LQFP64	plastic low profile quad flat package; 64 leads; body 10 × 10 × 1.4 mm	SOT314-2

4.1 Ordering options

Table 2. Part ordering options

Part Number	Flash (kB)	EEPROM (kB)	Main SRAM (kB)	USB SRAM (kB)	USB	I ² C-bus FM+	SSP	ADC channels	GPIO	Package
LPC11U22FBD48/301	16	1	6	2	1	1	2	8	40	LQFP48
LPC11U23FBD48/301	24	1	6	2	1	1	2	8	40	LQFP48
LPC11U24FHI33/301	32	2	6	2	1	1	2	8	26	HVQFN33 (5 × 5)
LPC11U24FBD48/301	32	2	6	2	1	1	2	8	40	LQFP48
LPC11U24FET48/301	32	2	6	2	1	1	2	8	40	TFBGA48
LPC11U24FHN33/401	32	4	8	2	1	1	2	8	26	HVQFN33 (7 × 7)
LPC11U24FBD48/401	32	4	8	2	1	1	2	8	40	LQFP48
LPC11U24FBD64/401	32	4	8	2	1	1	2	8	54	LQFP64

5. Block diagram

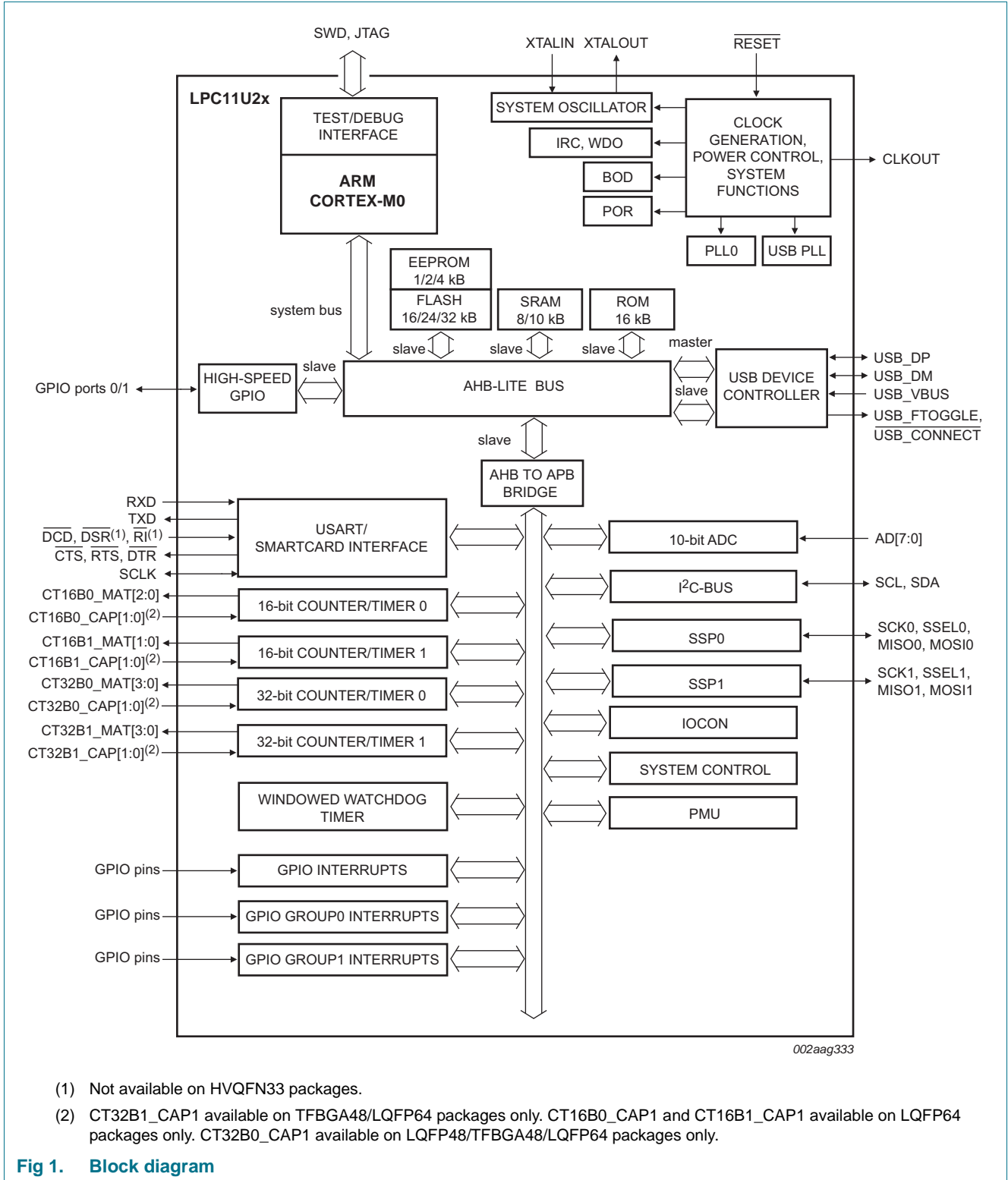

6. Pinning information

6.1 Pinning

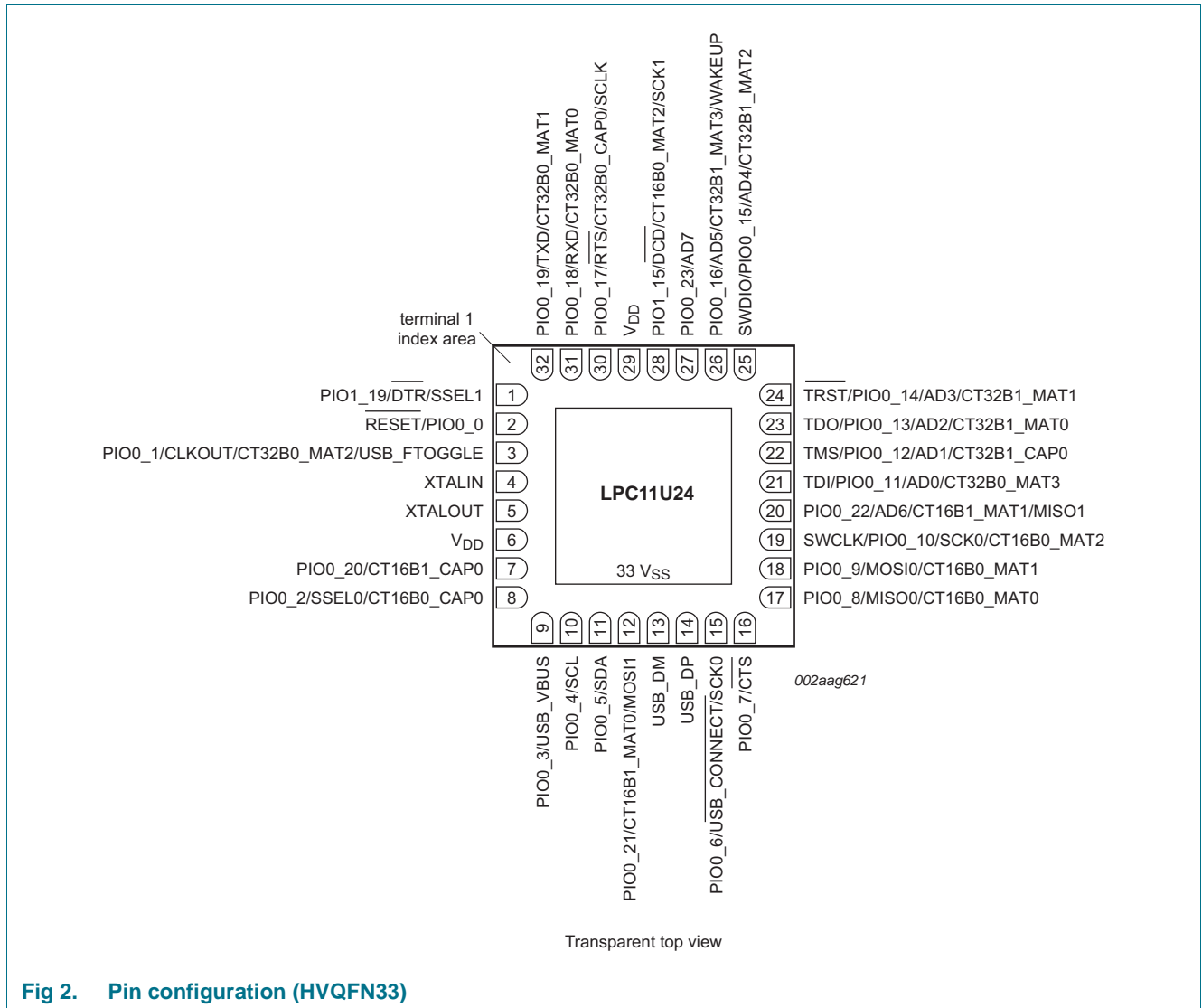

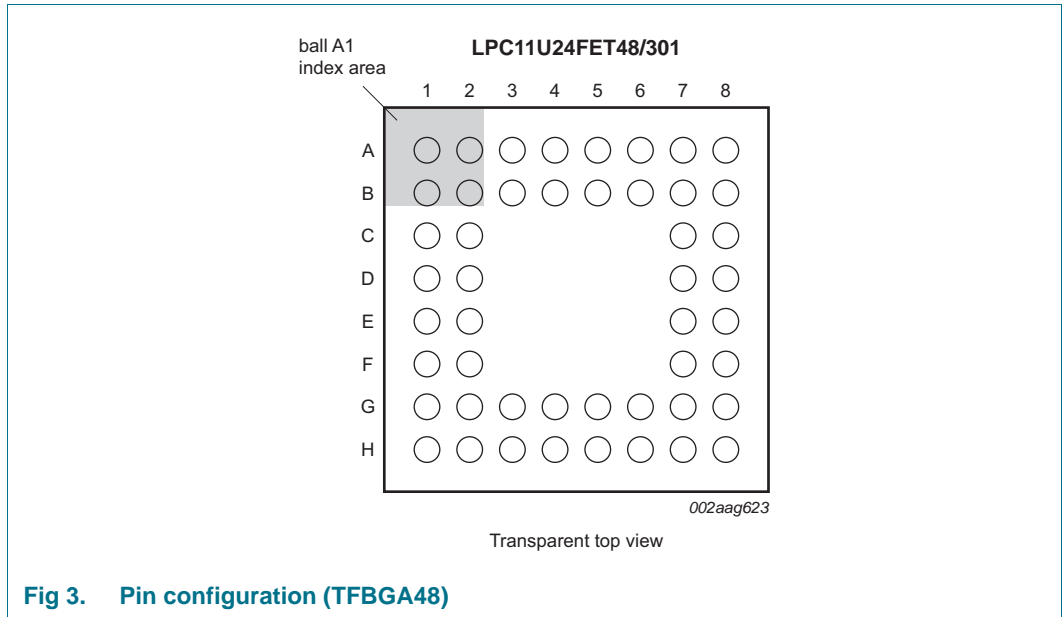

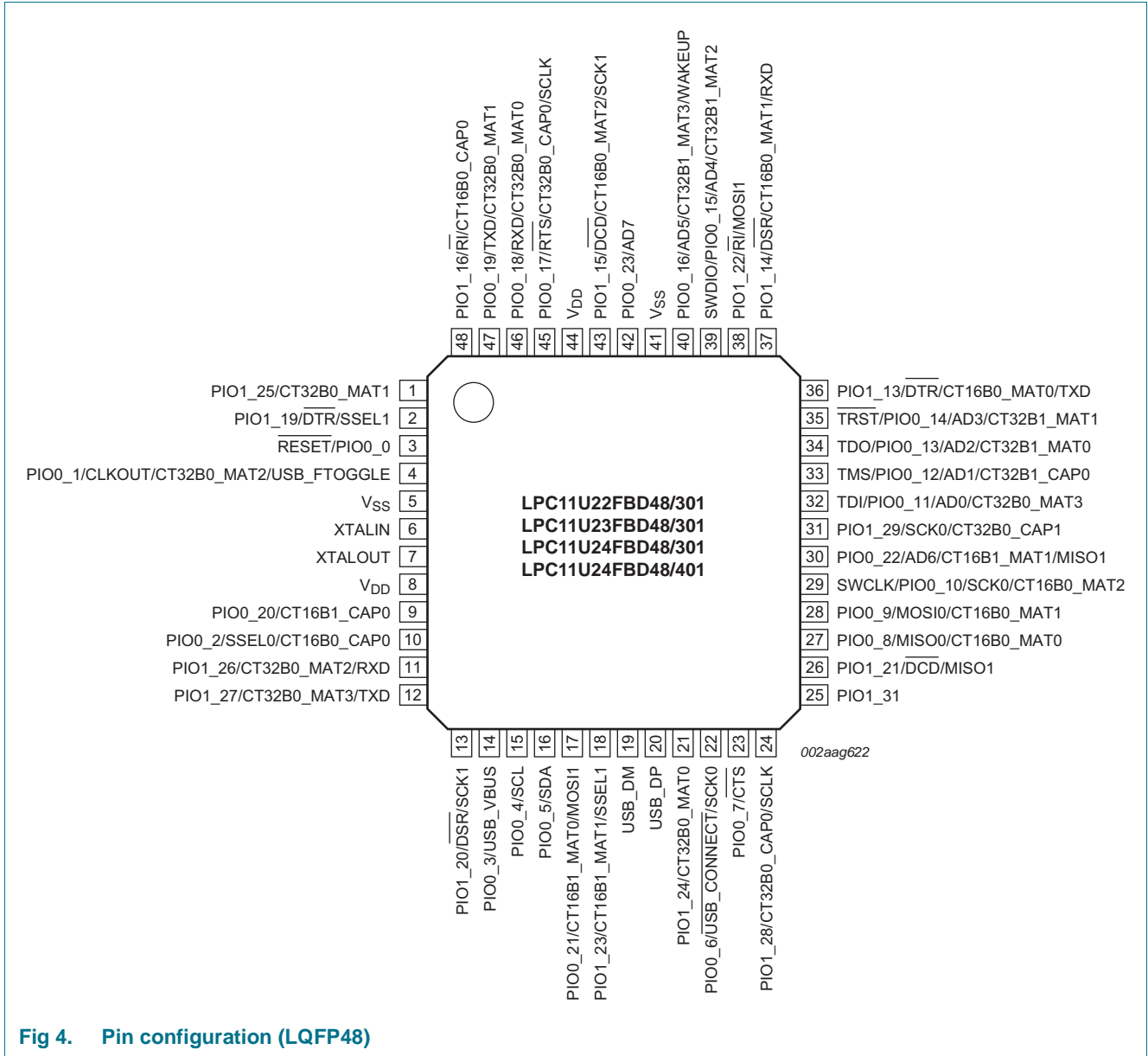
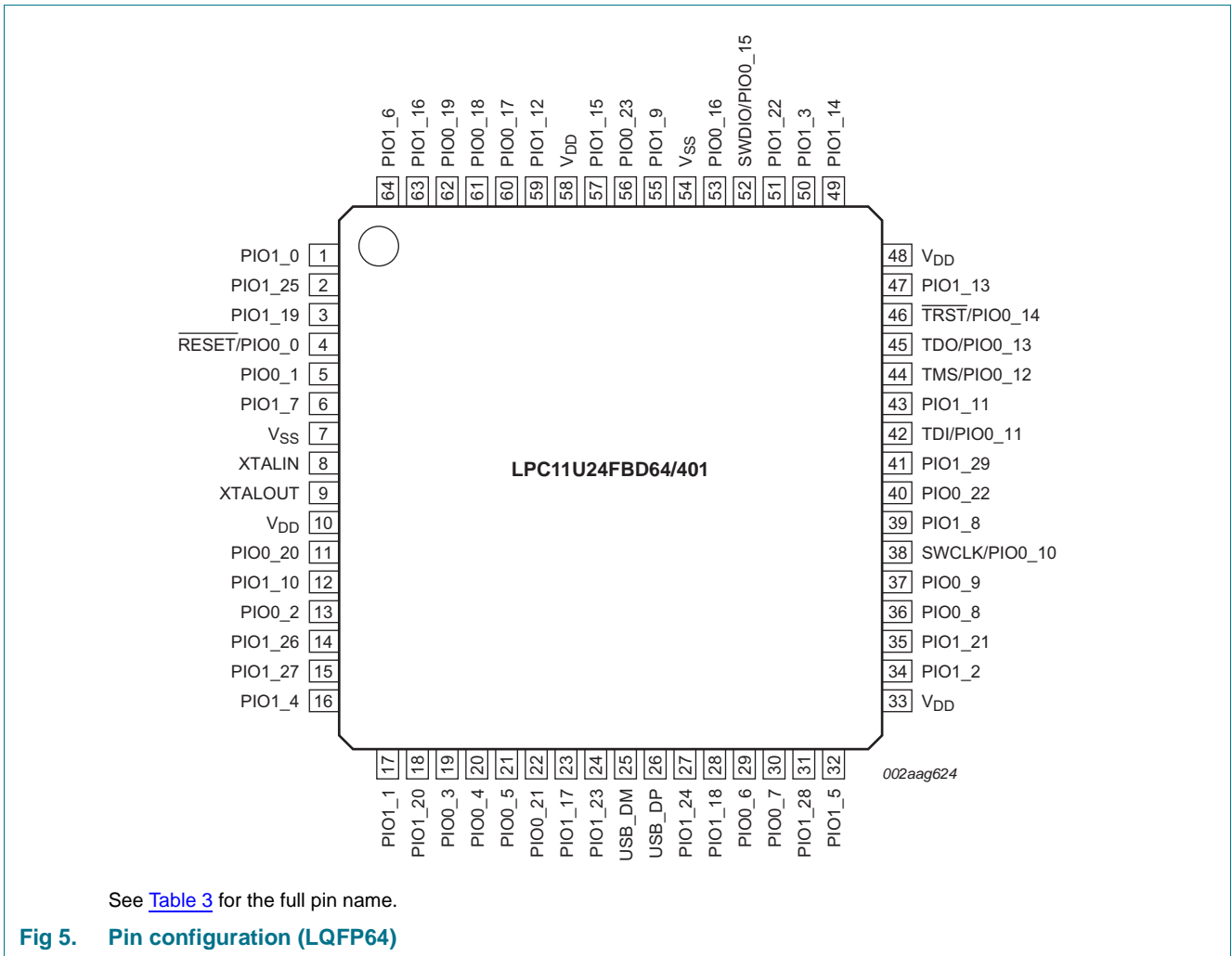

Fig 4. Pin configuration (LQFP48)



6.2 Pin description

Table 3 shows all pins and their assigned digital or analog functions in order of the GPIO port number. The default function after reset is listed first. All port pins have internal pull-up resistors enabled after reset except for the true open-drain pins PIO0_4 and PIO0_5.

Every port pin has a corresponding IOCON register for programming the digital or analog function, the pull-up/pull-down configuration, the repeater, and the open-drain modes.

The USART, counter/timer, and SSP functions are available on more than one port pin.

Table 3. Pin description

Symbol	Pin HVQFN33	Pin TFBGA48	Pin LQFP48	Pin LQFP64	Reset state [1]	Type	Description	
RESET/PIO0_0	2	C1	3	4	[2]	I; PU	I	RESET — External reset input with 20 ns glitch filter. A LOW-going pulse as short as 50 ns on this pin resets the device, causing I/O ports and peripherals to take on their default states, and processor execution to begin at address 0. This pin also serves as the debug select input. LOW level selects the JTAG boundary scan. HIGH level selects the ARM SWD debug mode. In deep power-down mode, this pin must be pulled HIGH externally. The RESET pin can be left unconnected or be used as a GPIO pin if an external RESET function is not needed and Deep power-down mode is not used.
					-	I/O	PIO0_0 — General purpose digital input/output pin.	
PIO0_1/CLKOUT/ CT32B0_MAT2/ USB_FTOGGLE	3	C2	4	5	[3]	I; PU	I/O	PIO0_1 — General purpose digital input/output pin. A LOW level on this pin during reset starts the ISP command handler or the USB device enumeration.
					-	O	CLKOUT — Clockout pin.	
					-	O	CT32B0_MAT2 — Match output 2 for 32-bit timer 0.	
					-	O	USB_FTOGGLE — USB 1 ms Start-of-Frame signal.	
PIO0_2/SSEL0/ CT16B0_CAP0	8	F1	10	13	[3]	I; PU	I/O	PIO0_2 — General purpose digital input/output pin.
					-	I/O	SSEL0 — Slave select for SSP0.	
					-	I	CT16B0_CAP0 — Capture input 0 for 16-bit timer 0.	
PIO0_3/USB_VBUS	9	H2	14	19	[3]	I; PU	I/O	PIO0_3 — General purpose digital input/output pin. A LOW level on this pin during reset starts the ISP command handler. A HIGH level during reset starts the USB device enumeration.
					-	I	USB_VBUS — Monitors the presence of USB bus power.	
PIO0_4/SCL	10	G3	15	20	[4]	I; IA	I/O	PIO0_4 — General purpose digital input/output pin (open-drain).
					-	I/O	SCL — I ² C-bus clock input/output (open-drain). High-current sink only if I ² C Fast-mode Plus is selected in the I/O configuration register.	

Table 3. Pin description

Symbol	Pin HVQFN33	Pin TFBGA48	Pin LQFP48	Pin LQFP64	Reset state [1]	Type	Description	
PIO0_5/SDA	11	H3	16	21	[4]	I; IA	I/O	PIO0_5 — General purpose digital input/output pin (open-drain).
					-	-	I/O	SDA — I ² C-bus data input/output (open-drain). High-current sink only if I ² C Fast-mode Plus is selected in the I/O configuration register.
PIO0_6/ <u>USB_CONNECT</u> / SCK0	15	H6	22	29	[3]	I; PU	I/O	PIO0_6 — General purpose digital input/output pin.
					-	-	O	USB_CONNECT — Signal used to switch an external 1.5 kΩ resistor under software control. Used with the SoftConnect USB feature.
					-	-	I/O	SCK0 — Serial clock for SSP0.
PIO0_7/ <u>CTS</u>	16	G7	23	30	[5]	I; PU	I/O	PIO0_7 — General purpose digital input/output pin (high-current output driver).
					-	-	I	CTS — Clear To Send input for USART.
PIO0_8/MISO0/ CT16B0_MAT0	17	F8	27	36	[3]	I; PU	I/O	PIO0_8 — General purpose digital input/output pin.
					-	-	I/O	MISO0 — Master In Slave Out for SSP0.
					-	-	O	CT16B0_MAT0 — Match output 0 for 16-bit timer 0.
PIO0_9/MOSI0/ CT16B0_MAT1	18	F7	28	37	[3]	I; PU	I/O	PIO0_9 — General purpose digital input/output pin.
					-	-	I/O	MOSI0 — Master Out Slave In for SSP0.
					-	-	O	CT16B0_MAT1 — Match output 1 for 16-bit timer 0.
SWCLK/PIO0_10/SCK0/ CT16B0_MAT2	19	E7	29	38	[3]	I; PU	I	SWCLK — Serial wire clock and test clock TCK for JTAG interface.
					-	-	I/O	PIO0_10 — General purpose digital input/output pin.
					-	-	O	SCK0 — Serial clock for SSP0.
					-	-	O	CT16B0_MAT2 — Match output 2 for 16-bit timer 0.
TDI/PIO0_11/AD0/ CT32B0_MAT3	21	D8	32	42	[6]	I; PU	I	TDI — Test Data In for JTAG interface.
					-	-	I/O	PIO0_11 — General purpose digital input/output pin.
					-	-	I	AD0 — A/D converter, input 0.
					-	-	O	CT32B0_MAT3 — Match output 3 for 32-bit timer 0.
TMS/PIO0_12/AD1/ CT32B1_CAP0	22	C7	33	44	[6]	I; PU	I	TMS — Test Mode Select for JTAG interface.
					-	-	I/O	PIO0_12 — General purpose digital input/output pin.
					-	-	I	AD1 — A/D converter, input 1.
					-	-	I	CT32B1_CAP0 — Capture input 0 for 32-bit timer 1.
TDO/PIO0_13/AD2/ CT32B1_MAT0	23	C8	34	45	[6]	I; PU	O	TDO — Test Data Out for JTAG interface.
					-	-	I/O	PIO0_13 — General purpose digital input/output pin.
					-	-	I	AD2 — A/D converter, input 2.
					-	-	O	CT32B1_MAT0 — Match output 0 for 32-bit timer 1.

Table 3. Pin description

Symbol	Pin HVQFN33	Pin TFBGA48	Pin LQFP48	Pin LQFP64	Reset state [1]	Type	Description	
TRST/PIO0_14/AD3/ CT32B1_MAT1	24	B7	35	46	[6]	I; PU	I	TRST — Test Reset for JTAG interface.
					-	I/O	PIO0_14 — General purpose digital input/output pin.	
					-	I	AD3 — A/D converter, input 3.	
					-	O	CT32B1_MAT1 — Match output 1 for 32-bit timer 1.	
SWDIO/PIO0_15/AD4/ CT32B1_MAT2	25	B6	39	52	[6]	I; PU	I/O	SWDIO — Serial wire debug input/output.
					-	I/O	PIO0_15 — General purpose digital input/output pin.	
					-	I	AD4 — A/D converter, input 4.	
					-	O	CT32B1_MAT2 — Match output 2 for 32-bit timer 1.	
PIO0_16/AD5/ CT32B1_MAT3/WAKEUP	26	A6	40	53	[6]	I; PU	I/O	PIO0_16 — General purpose digital input/output pin. In Deep power-down mode, this pin functions as the WAKEUP pin with 20 ns glitch filter. Pull this pin HIGH externally to enter Deep power-down mode. Pull this pin LOW to exit Deep power-down mode. A LOW-going pulse as short as 50 ns wakes up the part.
					-	I	AD5 — A/D converter, input 5.	
					-	O	CT32B1_MAT3 — Match output 3 for 32-bit timer 1.	
					-	I/O	WAKEUP — Wakeup pin with 20 ns glitch filter.	
PIO0_17/RTS/ CT32B0_CAP0/SCLK	30	A3	45	60	[3]	I; PU	I/O	PIO0_17 — General purpose digital input/output pin.
					-	O	RTS — Request To Send output for USART.	
					-	I	CT32B0_CAP0 — Capture input 0 for 32-bit timer 0.	
					-	I/O	SCLK — Serial clock input/output for USART in synchronous mode.	
PIO0_18/RXD/ CT32B0_MAT0	31	B3	46	61	[3]	I; PU	I/O	PIO0_18 — General purpose digital input/output pin.
					-	I	RXD — Receiver input for USART. Used in UART ISP mode.	
					-	O	CT32B0_MAT0 — Match output 0 for 32-bit timer 0.	
PIO0_19/TXD/ CT32B0_MAT1	32	B2	47	62	[3]	I; PU	I/O	PIO0_19 — General purpose digital input/output pin.
					-	O	TXD — Transmitter output for USART. Used in UART ISP mode.	
					-	O	CT32B0_MAT1 — Match output 1 for 32-bit timer 0.	
PIO0_20/CT16B1_CAP0	7	F2	9	11	[3]	I; PU	I/O	PIO0_20 — General purpose digital input/output pin.
					-	I	CT16B1_CAP0 — Capture input 0 for 16-bit timer 1.	
PIO0_21/CT16B1_MAT0/ MOSI1	12	G4	17	22	[3]	I; PU	I/O	PIO0_21 — General purpose digital input/output pin.
					-	O	CT16B1_MAT0 — Match output 0 for 16-bit timer 1.	
					-	I/O	MOSI1 — Master Out Slave In for SSP1.	
PIO0_22/AD6/ CT16B1_MAT1/MISO1	20	E8	30	40	[6]	I; PU	I/O	PIO0_22 — General purpose digital input/output pin.
					-	I	AD6 — A/D converter, input 6.	
					-	O	CT16B1_MAT1 — Match output 1 for 16-bit timer 1.	
					-	I/O	MISO1 — Master In Slave Out for SSP1.	

Table 3. Pin description

Symbol	Pin HVQFN33	Pin TFBGA48	Pin LQFP48	Pin LQFP64	Reset state [1]	Type	Description
PIO0_23/AD7	27	A5	42	56 [6]	I; PU	I/O	PIO0_23 — General purpose digital input/output pin.
					-	I	AD7 — A/D converter, input 7.
PIO1_0/CT32B1_MAT0	-	-	-	1 [3]	I; PU	I/O	PIO1_0 — General purpose digital input/output pin.
					-	O	CT32B1_MAT0 — Match output 0 for 32-bit timer 1.
PIO1_1/CT32B1_MAT1	-	-	-	17 [3]	I; PU	I/O	PIO1_1 — General purpose digital input/output pin.
					-	O	CT32B1_MAT1 — Match output 1 for 32-bit timer 1.
PIO1_2/CT32B1_MAT2	-	-	-	34 [3]	I; PU	I/O	PIO1_2 — General purpose digital input/output pin.
					-	O	CT32B1_MAT2 — Match output 2 for 32-bit timer 1.
PIO1_3/CT32B1_MAT3	-	-	-	50 [3]	I; PU	I/O	PIO1_3 — General purpose digital input/output pin.
					-	O	CT32B1_MAT3 — Match output 3 for 32-bit timer 1.
PIO1_4/CT32B1_CAP0	-	-	-	16 [3]	I; PU	I/O	PIO1_4 — General purpose digital input/output pin.
					-	I	CT32B1_CAP0 — Capture input 0 for 32-bit timer 1.
PIO1_5/CT32B1_CAP1	-	H8	-	32 [3]	I; PU	I/O	PIO1_5 — General purpose digital input/output pin.
					-	I	CT32B1_CAP1 — Capture input 1 for 32-bit timer 1.
PIO1_6	-	-	-	64 [3]	I; PU	I/O	PIO1_6 — General purpose digital input/output pin.
PIO1_7	-	-	-	6 [3]	I; PU	I/O	PIO1_7 — General purpose digital input/output pin.
PIO1_8	-	-	-	39 [3]	I; PU	I/O	PIO1_8 — General purpose digital input/output pin.
PIO1_9	-	-	-	55 [3]	I; PU	I/O	PIO1_9 — General purpose digital input/output pin.
PIO1_10	-	-	-	12 [3]	I; PU	I/O	PIO1_10 — General purpose digital input/output pin.
PIO1_11	-	-	-	43 [3]	I; PU	I/O	PIO1_11 — General purpose digital input/output pin.
PIO1_12	-	-	-	59 [3]	I; PU	I/O	PIO1_12 — General purpose digital input/output pin.
PIO1_13/DTR/ CT16B0_MAT0/TXD	-	B8	36	47 [3]	I; PU	I/O	PIO1_13 — General purpose digital input/output pin.
					-	O	DTR — Data Terminal Ready output for USART.
					-	O	CT16B0_MAT0 — Match output 0 for 16-bit timer 0.
					-	O	TXD — Transmitter output for USART.
PIO1_14/DSR/ CT16B0_MAT1/RXD	-	A8	37	49 [3]	I; PU	I/O	PIO1_14 — General purpose digital input/output pin.
					-	I	DSR — Data Set Ready input for USART.
					-	O	CT16B0_MAT1 — Match output 1 for 16-bit timer 0.
					-	I	RXD — Receiver input for USART.
PIO1_15/DCD/ CT16B0_MAT2/SCK1	28	A4	43	57 [3]	I; PU	I/O	PIO1_15 — General purpose digital input/output pin.
					-	I	DCD — Data Carrier Detect input for USART.
					-	O	CT16B0_MAT2 — Match output 2 for 16-bit timer 0.
					-	I/O	SCK1 — Serial clock for SSP1.
PIO1_16/RI/ CT16B0_CAP0	-	A2	48	63 [3]	I; PU	I/O	PIO1_16 — General purpose digital input/output pin.
					-	I	RI — Ring Indicator input for USART.
					-	I	CT16B0_CAP0 — Capture input 0 for 16-bit timer 0.

Table 3. Pin description

Symbol	Pin HVQFN33	Pin TFBGA48	Pin LQFP48	Pin LQFP64	Reset state [1]	Type	Description
PIO1_17/CT16B0_CAP1/RXD	-	-	-	23 [3]	I; PU	I/O	PIO1_17 — General purpose digital input/output pin.
					-	I	CT16B0_CAP1 — Capture input 1 for 16-bit timer 0.
					-	I	RXD — Receiver input for USART.
PIO1_18/CT16B1_CAP1/TXD	-	-	-	28 [3]	I; PU	I/O	PIO1_18 — General purpose digital input/output pin.
					-	I	CT16B1_CAP1 — Capture input 1 for 16-bit timer 1.
					-	O	TXD — Transmitter output for USART.
PIO1_19/DTR/SSEL1	1	B1	2	3 [3]	I; PU	I/O	PIO1_19 — General purpose digital input/output pin.
					-	O	DTR — Data Terminal Ready output for USART.
					-	I/O	SSEL1 — Slave select for SSP1.
PIO1_20/DSR/SCK1	-	H1	13	18 [3]	I; PU	I/O	PIO1_20 — General purpose digital input/output pin.
					-	I	DSR — Data Set Ready input for USART.
					-	I/O	SCK1 — Serial clock for SSP1.
PIO1_21/DCD/MISO1	-	G8	26	35 [3]	I; PU	I/O	PIO1_21 — General purpose digital input/output pin.
					-	I	DCD — Data Carrier Detect input for USART.
					-	I/O	MISO1 — Master In Slave Out for SSP1.
PIO1_22/RI/MOSI1	-	A7	38	51 [3]	I; PU	I/O	PIO1_22 — General purpose digital input/output pin.
					-	I	RI — Ring Indicator input for USART.
					-	I/O	MOSI1 — Master Out Slave In for SSP1.
PIO1_23/CT16B1_MAT1/SSEL1	-	H4	18	24 [3]	I; PU	I/O	PIO1_23 — General purpose digital input/output pin.
					-	O	CT16B1_MAT1 — Match output 1 for 16-bit timer 1.
					-	I/O	SSEL1 — Slave select for SSP1.
PIO1_24/CT32B0_MAT0	-	G6	21	27 [3]	I; PU	I/O	PIO1_24 — General purpose digital input/output pin.
					-	O	CT32B0_MAT0 — Match output 0 for 32-bit timer 0.
PIO1_25/CT32B0_MAT1	-	A1	1	2 [3]	I; PU	I/O	PIO1_25 — General purpose digital input/output pin.
					-	O	CT32B0_MAT1 — Match output 1 for 32-bit timer 0.
PIO1_26/CT32B0_MAT2/RXD	-	G2	11	14 [3]	I; PU	I/O	PIO1_26 — General purpose digital input/output pin.
					-	O	CT32B0_MAT2 — Match output 2 for 32-bit timer 0.
					-	I	RXD — Receiver input for USART.
PIO1_27/CT32B0_MAT3/TXD	-	G1	12	15 [3]	I; PU	I/O	PIO1_27 — General purpose digital input/output pin.
					-	O	CT32B0_MAT3 — Match output 3 for 32-bit timer 0.
					-	O	TXD — Transmitter output for USART.
PIO1_28/CT32B0_CAP0/SCLK	-	H7	24	31 [3]	I; PU	I/O	PIO1_28 — General purpose digital input/output pin.
					-	I	CT32B0_CAP0 — Capture input 0 for 32-bit timer 0.
					-	I/O	SCLK — Serial clock input/output for USART in synchronous mode.
PIO1_29/SCK0/CT32B0_CAP1	-	D7	31	41 [3]	I; PU	I/O	PIO1_29 — General purpose digital input/output pin.
					-	I/O	SCK0 — Serial clock for SSP0.
					-	I	CT32B0_CAP1 — Capture input 1 for 32-bit timer 0.

Table 3. Pin description

Symbol	Pin HVQFN33	Pin TFBGA48	Pin LQFP48	Pin LQFP64	Reset state [1]	Type	Description
PIO1_31	-	-	25	- [3]	I; PU	I/O	PIO1_31 — General purpose digital input/output pin.
USB_DM	13	G5	19	25 [7]	F	-	USB_DM — USB bidirectional D- line.
USB_DP	14	H5	20	26 [7]	F	-	USB_DP — USB bidirectional D+ line.
XTALIN	4	D1	6	8 [8]	-	-	Input to the oscillator circuit and internal clock generator circuits. Input voltage must not exceed 1.8 V.
XTALOUT	5	E1	7	9 [8]	-	-	Output from the oscillator amplifier.
V _{DD}	6; 29	B4; E2	8; 44	10; 33; 48; 58	-	-	Supply voltage to the internal regulator, the external rail, and the ADC. Also used as the ADC reference voltage.
V _{SS}	33	B5; D2	5; 41	7; 54	-	-	Ground.

- [1] Pin state at reset for default function: I = Input; O = Output; PU = internal pull-up enabled; IA = inactive, no pull-up/down enabled; F = floating; If the pins are not used, tie floating pins to ground or power to minimize power consumption.
- [2] 5 V tolerant pad. RESET functionality is not available in Deep power-down mode. Use the WAKEUP pin to reset the chip and wake up from Deep power-down mode. An external pull-up resistor is required on this pin for the Deep power-down mode. See [Figure 32](#) for the reset pad configuration.
- [3] 5 V tolerant pad providing digital I/O functions with configurable pull-up/pull-down resistors and configurable hysteresis (see [Figure 31](#)).
- [4] I²C-bus pin compliant with the I²C-bus specification for I²C standard mode, I²C Fast-mode, and I²C Fast-mode Plus. The pin requires an external pull-up to provide output functionality. When power is switched off, this pin is floating and does not disturb the I2C lines. Open-drain configuration applies to all functions on this pin.
- [5] 5 V tolerant pad providing digital I/O functions with configurable pull-up/pull-down resistors and configurable hysteresis (see [Figure 31](#)); includes high-current output driver.
- [6] 5 V tolerant pad providing digital I/O functions with configurable pull-up/pull-down resistors, configurable hysteresis, and analog input. When configured as a ADC input, digital section of the pad is disabled and the pin is not 5 V tolerant (see [Figure 31](#)); includes digital input glitch filter.
- [7] Pad provides USB functions. It is designed in accordance with the USB specification, revision 2.0 (Full-speed and Low-speed mode only). This pad is not 5 V tolerant.
- [8] When the system oscillator is not used, connect XTALIN and XTALOUT as follows: XTALIN can be left floating or can be grounded (grounding is preferred to reduce susceptibility to noise). Leave XTALOUT floating.

7. Functional description

7.1 On-chip flash programming memory

The LPC11U2x contain 24 kB or 32 kB on-chip flash program memory. The flash can be programmed using In-System Programming (ISP) or In-Application Programming (IAP) via the on-chip boot loader software.

7.2 EEPROM

The LPC11U2x contain 1 kB, 2 kB, or 4 kB of on-chip byte-erasable and byte-programmable EEPROM data memory. The EEPROM can be programmed using In-Application Programming (IAP) via the on-chip boot loader software.

7.3 SRAM

The LPC11U2x contain a total of 8 kB or 10 kB on-chip static RAM memory.

7.4 On-chip ROM

The on-chip ROM contains the boot loader and the following Application Programming Interfaces (APIs):

- In-System Programming (ISP) and In-Application Programming (IAP) support for flash
- IAP support for EEPROM
- USB API
- Power profiles for configuring power consumption and PLL settings
- 32-bit integer division routines

7.5 Memory map

The LPC11U2x incorporates several distinct memory regions, shown in the following figures. [Figure 6](#) shows the overall map of the entire address space from the user program viewpoint following reset. The interrupt vector area supports address remapping.

The AHB (Advanced High-performance Bus) peripheral area is 2 MB in size and is divided to allow for up to 128 peripherals. The APB (Advanced Peripheral Bus) peripheral area is 512 kB in size and is divided to allow for up to 32 peripherals. Each peripheral of either type is allocated 16 kB of space. This addressing scheme allows simplifying the address decoding for each peripheral.

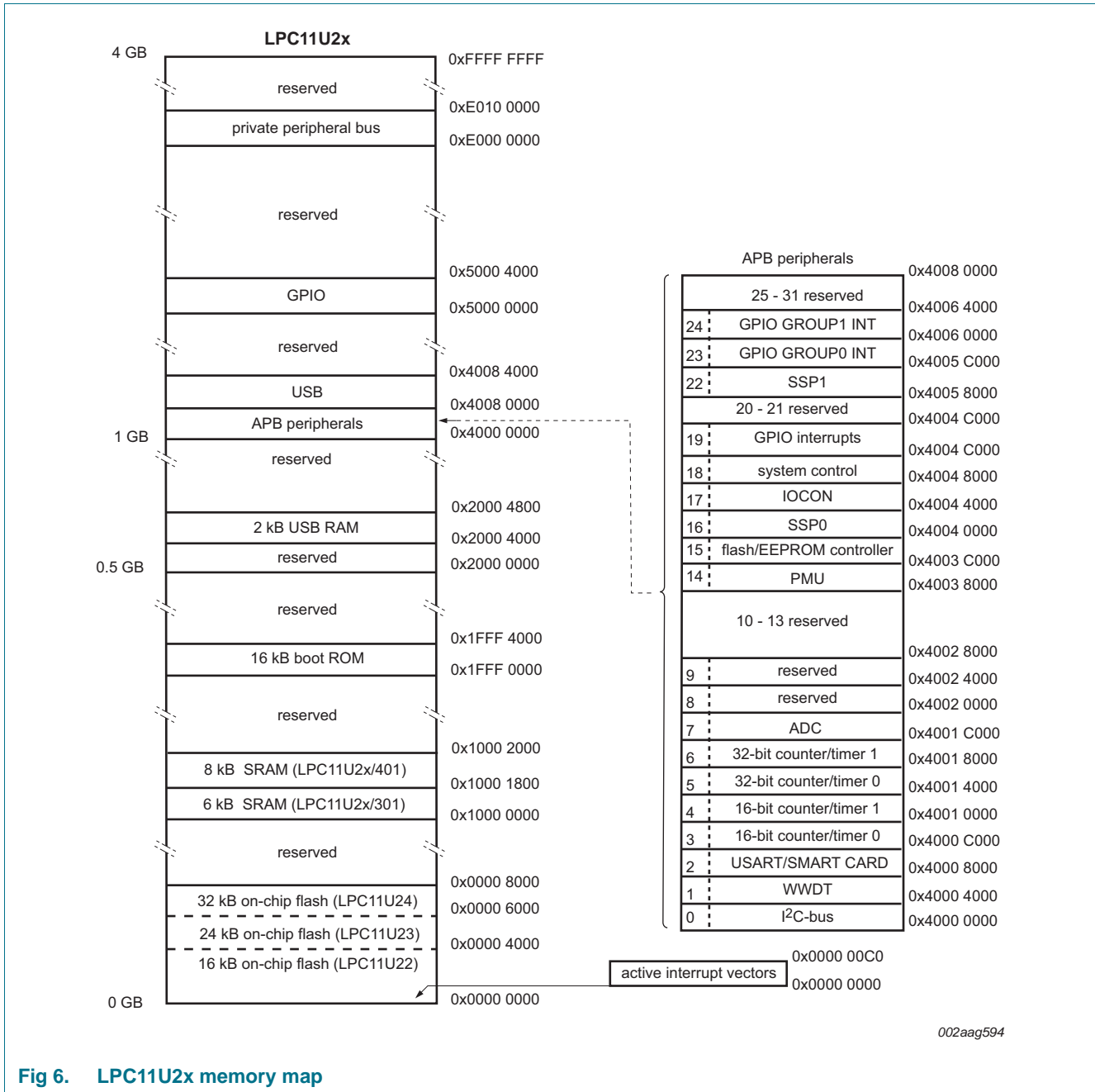

Fig 6. LPC11U2x memory map

7.6 Nested Vectored Interrupt Controller (NVIC)

The Nested Vectored Interrupt Controller (NVIC) is part of the Cortex-M0. The tight coupling to the CPU allows for low interrupt latency and efficient processing of late arriving interrupts.

7.6.1 Features

- Controls system exceptions and peripheral interrupts.
- In the LPC11U2x, the NVIC supports 24 vectored interrupts.

- Four programmable interrupt priority levels, with hardware priority level masking.
- Software interrupt generation.

7.6.2 Interrupt sources

Each peripheral device has one interrupt line connected to the NVIC but can have several interrupt flags. Individual interrupt flags can also represent more than one interrupt source.

7.7 IOCON block

The IOCON block allows selected pins of the microcontroller to have more than one function. Configuration registers control the multiplexers to allow connection between the pin and the on-chip peripherals.

Connect peripherals to the appropriate pins before activating the peripheral and before enabling any related interrupt. Activity of any enabled peripheral function that is not mapped to a related pin is treated as undefined.

7.7.1 Features

- Programmable pull-up, pull-down, or repeater mode.
- All GPIO pins (except PIO0_4 and PIO0_5) are pulled up to 3.3 V ($V_{DD} = 3.3$ V) if their pull-up resistor is enabled.
- Programmable pseudo open-drain mode.
- Programmable 10 ns glitch filter on pins PIO0_22, PIO0_23, and PIO0_11 to PIO0_16. The glitch filter is turned on by default.
- Programmable hysteresis.
- Programmable input inverter.

7.8 General-Purpose Input/Output GPIO

The GPIO registers control device pin functions that are not connected to a specific peripheral function. Pins can be dynamically configured as inputs or outputs. Multiple outputs can be set or cleared in one write operation.

LPC11U2x use accelerated GPIO functions:

- GPIO registers are a dedicated AHB peripheral so that the fastest possible I/O timing can be achieved.
- Entire port value can be written in one instruction.

Any GPIO pin providing a digital function can be programmed to generate an interrupt on a level, a rising or falling edge, or both.

The GPIO block consists of three parts:

1. The GPIO ports.
2. The GPIO pin interrupt block to control eight GPIO pins selected as pin interrupts.
3. Two GPIO group interrupt blocks to control two combined interrupts from all GPIO pins.

7.8.1 Features

- GPIO pins can be configured as input or output by software.
- All GPIO pins default to inputs with interrupt disabled at reset.
- Pin registers allow pins to be sensed and set individually.
- Up to eight GPIO pins can be selected from all GPIO pins to create an edge- or level-sensitive GPIO interrupt request.
- Any pin or pins in each port can trigger a port interrupt.

7.9 USB interface

The Universal Serial Bus (USB) is a 4-wire bus that supports communication between a host and one or more (up to 127) peripherals. The host controller allocates the USB bandwidth to attached devices through a token-based protocol. The bus supports hot-plugging and dynamic configuration of the devices. The host controller initiates all transactions.

The LPC11U2x USB interface consists of a full-speed device controller with on-chip PHY (PHYsical layer) for device functions.

Remark: Configure the LPC11U2x in default power mode with the power profiles before using the USB (see [Section 7.17.5.1](#)). Do not use the USB with the part in performance, efficiency, or low-power mode.

7.9.1 Full-speed USB device controller

The device controller enables 12 Mbit/s data exchange with a USB Host controller. It consists of a register interface, serial interface engine, and endpoint buffer memory. The serial interface engine decodes the USB data stream and writes data to the appropriate endpoint buffer. The status of a completed USB transfer or error condition is indicated via status registers. If enabled, an interrupt is generated.

7.9.1.1 Features

- Dedicated USB PLL available.
- Fully compliant with *USB 2.0 specification (full speed)*.
- Supports 10 physical (5 logical) endpoints including one control endpoint.
- Single and double buffering supported.
- Each non-control endpoint supports bulk, interrupt, or isochronous endpoint types.
- Supports wake-up from Deep-sleep mode and Power-down mode on USB activity and remote wake-up.
- Supports SoftConnect.

7.10 USART

The LPC11U2x contains one USART.

The USART includes full modem control, support for synchronous mode, and a smart card interface. The RS-485/9-bit mode allows both software address detection and automatic address detection using 9-bit mode.

The USART uses a fractional baud rate generator. Standard baud rates such as 115200 Bd can be achieved with any crystal frequency above 2 MHz.

7.10.1 Features

- Maximum USART data bit rate of 3.125 Mbit/s.
- 16 byte receive and transmit FIFOs.
- Register locations conform to 16C550 industry standard.
- Receiver FIFO trigger points at 1 B, 4 B, 8 B, and 14 B.
- Built-in fractional baud rate generator covering wide range of baud rates without a need for external crystals of particular values.
- Fractional divider for baud rate control, auto baud capabilities and FIFO control mechanism that enables software flow control implementation.
- Support for RS-485/9-bit mode.
- Support for modem control.
- Support for synchronous mode.
- Includes smart card interface.

7.11 SSP serial I/O controller

The SSP controllers operate on a SSP, 4-wire SSI, or Microwire bus. It can interact with multiple masters and slaves on the bus. Only a single master and a single slave can communicate on the bus during a given data transfer. The SSP supports full duplex transfers, with frames of 4 bit to 16 bit of data flowing from the master to the slave and from the slave to the master. In practice, often only one of these data flows carries meaningful data.

7.11.1 Features

- Maximum SSP speed of 25 Mbit/s (master) or 4.17 Mbit/s (slave) (in SSP mode)
- Compatible with Motorola SPI (Serial Peripheral Interface), 4-wire Texas Instruments SSI (Serial Synchronous Interface), and National Semiconductor Microwire buses
- Synchronous serial communication
- Master or slave operation
- 8-frame FIFOs for both transmit and receive
- 4-bit to 16-bit frame

7.12 I²C-bus serial I/O controller

The LPC11U2x contain one I²C-bus controller.

The I²C-bus is bidirectional for inter-IC control using only two wires: a Serial CLock line (SCL) and a Serial DATa line (SDA). Each device is recognized by a unique address and can operate as either a receiver-only device (e.g., an LCD driver) or a transmitter with the capability to both receive and send information (such as memory). Transmitters and/or receivers can operate in either master or slave mode, depending on whether the chip has to initiate a data transfer or is only addressed. The I²C-bus is a multi-master bus, and more than one bus master connected to the interface can be controlled the bus.

7.12.1 Features

- The I²C-interface is an I²C-bus compliant interface with open-drain pins. The I²C-bus interface supports Fast-mode Plus with bit rates up to 1 Mbit/s.
- Easy to configure as master, slave, or master/slave.
- Programmable clocks allow versatile rate control.
- Bidirectional data transfer between masters and slaves.
- Multi-master bus (no central master).
- Arbitration between simultaneously transmitting masters without corruption of serial data on the bus.
- Serial clock synchronization allows devices with different bit rates to communicate via one serial bus.
- Serial clock synchronization can be used as a handshake mechanism to suspend and resume serial transfer.
- The I²C-bus can be used for test and diagnostic purposes.
- The I²C-bus controller supports multiple address recognition and a bus monitor mode.

7.13 10-bit ADC

The LPC11U2x contains one ADC. It is a single 10-bit successive approximation ADC with eight channels.

7.13.1 Features

- 10-bit successive approximation ADC.
- Input multiplexing among 8 pins.
- Power-down mode.
- Measurement range 0 V to V_{DD}.
- 10-bit conversion time $\geq 2.44 \mu\text{s}$ (up to 400 kSamples/s).
- Burst conversion mode for single or multiple inputs.
- Optional conversion on transition of input pin or timer match signal.
- Individual result registers for each ADC channel to reduce interrupt overhead.

7.14 General purpose external event counter/timers

The LPC11U2x includes two 32-bit counter/timers and two 16-bit counter/timers. The counter/timer is designed to count cycles of the system derived clock. It can optionally generate interrupts or perform other actions at specified timer values, based on four match registers. Each counter/timer also includes one capture input to trap the timer value when an input signal transitions, optionally generating an interrupt.

7.14.1 Features

- A 32-bit/16-bit timer/counter with a programmable 32-bit/16-bit prescaler.
- Counter or timer operation.
- One capture channel per timer, that can take a snapshot of the timer value when an input signal transitions. A capture event can also generate an interrupt.

- Four match registers per timer that allow:
 - Continuous operation with optional interrupt generation on match.
 - Stop timer on match with optional interrupt generation.
 - Reset timer on match with optional interrupt generation.
- Up to four external outputs corresponding to match registers, with the following capabilities:
 - Set LOW on match.
 - Set HIGH on match.
 - Toggle on match.
 - Do nothing on match.
- The timer and prescaler can be configured to be cleared on a designated capture event. This feature permits easy pulse-width measurement by clearing the timer on the leading edge of an input pulse and capturing the timer value on the trailing edge.

7.15 System tick timer

The ARM Cortex-M0 includes a system tick timer (SYSTICK) that is intended to generate a dedicated SYSTICK exception at a fixed time interval (typically 10 ms).

7.16 Windowed WatchDog Timer (WWDT)

The purpose of the WWDT is to prevent an unresponsive system state. If software fails to update the watchdog within a programmable time window, the watchdog resets the microcontroller

7.16.1 Features

- Internally resets chip if not periodically reloaded during the programmable time-out period.
- Optional windowed operation requires reload to occur between a minimum and maximum time period, both programmable.
- Optional warning interrupt can be generated at a programmable time before watchdog time-out.
- Software enables the WWDT, but a hardware reset or a watchdog reset/interrupt is required to disable the WWDT.
- Incorrect feed sequence causes reset or interrupt, if enabled.
- Flag to indicate watchdog reset.
- Programmable 24-bit timer with internal prescaler.
- Selectable time period from $(T_{cy(WDCLK)} \times 256 \times 4)$ to $(T_{cy(WDCLK)} \times 2^{24} \times 4)$ in multiples of $T_{cy(WDCLK)} \times 4$.
- The Watchdog Clock (WDCLK) source can be selected from the IRC or the dedicated watchdog oscillator (WDO). The clock source selection provides a wide range of potential timing choices of watchdog operation under different power conditions.

7.17 Clocking and power control

7.17.1 Integrated oscillators

The LPC11U2x include three independent oscillators: the system oscillator, the Internal RC oscillator (IRC), and the watchdog oscillator. Each oscillator can be used for more than one purpose as required in a particular application.

Following reset, the LPC11U2x operates from the internal RC oscillator until software switches to a different clock source. The IRC allows the system to operate without any external crystal and the bootloader code to operate at a known frequency.

See [Figure 7](#) for an overview of the LPC11U2x clock generation.

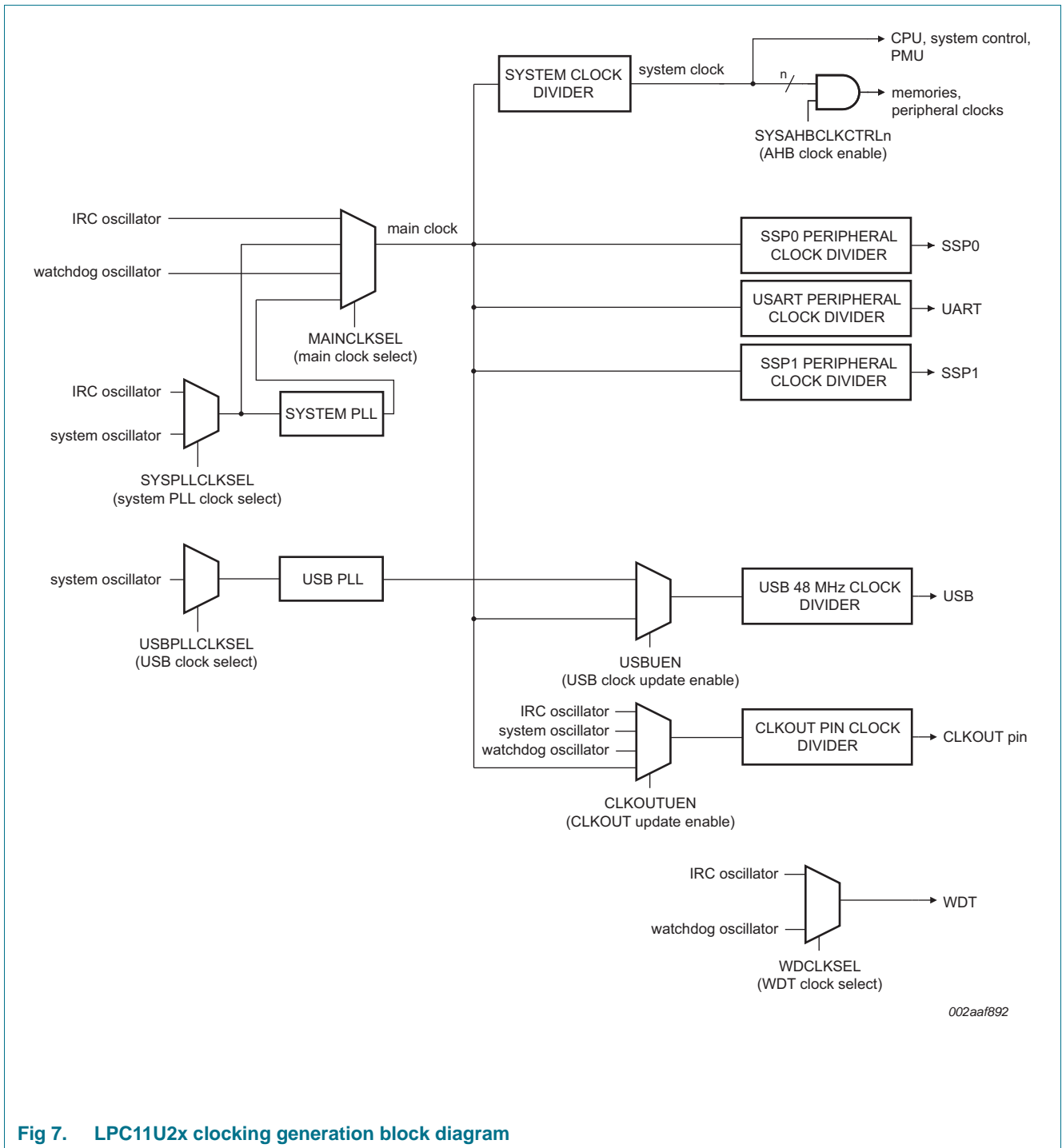

Fig 7. LPC11U2x clocking generation block diagram

7.17.1.1 Internal RC oscillator

The IRC can be used as the clock source for the WDT, and/or as the clock that drives the system PLL and then the CPU. The nominal IRC frequency is 12 MHz.

Upon power-up, any chip reset, or wake-up from Deep power-down mode, the LPC11U2x use the IRC as the clock source. Software can later switch to one of the other available clock sources.

7.17.1.2 System oscillator

The system oscillator can be used as the clock source for the CPU, with or without using the PLL. On the LPC11U2x, use the system oscillator to provide the clock source to USB.

The system oscillator operates at frequencies of 1 MHz to 25 MHz. This frequency can be boosted to a higher frequency, up to the maximum CPU operating frequency, by the system PLL.

7.17.1.3 Watchdog oscillator

The watchdog oscillator can be used as a clock source that directly drives the CPU, the watchdog timer, or the CLKOUT pin. The watchdog oscillator nominal frequency is programmable between 7.8 kHz and 1.7 MHz. The frequency spread over processing and temperature is $\pm 40\%$ (see also [Table 13](#)).

7.17.2 System PLL and USB PLL

The LPC11U2x contain a system PLL and a dedicated PLL for generating the 48 MHz USB clock. The system and USB PLLs are identical.

The PLL accepts an input clock frequency in the range of 10 MHz to 25 MHz. The input frequency is multiplied up to a high frequency with a Current Controlled Oscillator (CCO). The multiplier can be an integer value from 1 to 32. The CCO operates in the range of 156 MHz to 320 MHz. To support this frequency range, an additional divider keeps the CCO within its frequency range while the PLL is providing the desired output frequency. The output divider can be set to divide by 2, 4, 8, or 16 to produce the output clock. The PLL output frequency must be lower than 100 MHz. Since the minimum output divider value is 2, it is insured that the PLL output has a 50 % duty cycle. The PLL is turned off and bypassed following a chip reset. Software can enable the PLL later. The program must configure and activate the PLL, wait for the PLL to lock, and then connect to the PLL as a clock source. The PLL settling time is 100 μ s.

7.17.3 Clock output

The LPC11U2x feature a clock output function that routes the IRC oscillator, the system oscillator, the watchdog oscillator, or the main clock to an output pin.

7.17.4 Wake-up process

The LPC11U2x begin operation by using the 12 MHz IRC oscillator as the clock source at power-up and when awakened from Deep power-down mode. This mechanism allows chip operation to resume quickly. If the application uses the main oscillator or the PLL, software must enable these components and wait for them to stabilize. Only then can the system use the PLL and main oscillator as a clock source.

7.17.5 Power control

The LPC11U2x support various power control features. There are four special modes of processor power reduction: Sleep mode, Deep-sleep mode, Power-down mode, and Deep power-down mode. The CPU clock rate can also be controlled as needed by changing clock sources, reconfiguring PLL values, and/or altering the CPU clock divider value. This power control mechanism allows a trade-off of power versus processing speed based on application requirements. In addition, a register is provided for shutting down the clocks to individual on-chip peripherals. This register allows fine-tuning of power

consumption by eliminating all dynamic power use in any peripherals that are not required for the application. Selected peripherals have their own clock divider which provides even better power control.

7.17.5.1 Power profiles

The power consumption in Active and Sleep modes can be optimized for the application through simple calls to the power profile. The power configuration routine configures the LPC11U2x for one of the following power modes:

- Default mode corresponding to power configuration after reset.
- CPU performance mode corresponding to optimized processing capability.
- Efficiency mode corresponding to optimized balance of current consumption and CPU performance.
- Low-current mode corresponding to lowest power consumption.

In addition, the power profile includes routines to select the optimal PLL settings for a given system clock and PLL input clock.

Remark: When using the USB, configure the LPC11U2x in Default mode.

7.17.5.2 Sleep mode

When Sleep mode is entered, the clock to the core is stopped. Resumption from the Sleep mode does not need any special sequence but re-enabling the clock to the ARM core.

In Sleep mode, execution of instructions is suspended until either a reset or interrupt occurs. Peripheral functions continue operation during Sleep mode and can generate interrupts to cause the processor to resume execution. Sleep mode eliminates dynamic power used by the processor itself, by memory systems and related controllers, and by internal buses.

7.17.5.3 Deep-sleep mode

In Deep-sleep mode, the LPC11U2x is in Sleep-mode and all peripheral clocks and all clock sources are off except for the IRC. The IRC output is disabled unless the IRC is selected as input to the watchdog timer. In addition all analog blocks are shut down and the flash is in stand-by mode. In Deep-sleep mode, the application can keep the watchdog oscillator and the BOD circuit running for self-timed wake-up and BOD protection.

The LPC11U2x can wake up from Deep-sleep mode via reset, selected GPIO pins, a watchdog timer interrupt, or an interrupt generating USB port activity.

Deep-sleep mode saves power and allows for short wake-up times.

7.17.5.4 Power-down mode

In Power-down mode, the LPC11U2x is in Sleep-mode and all peripheral clocks and all clock sources are off except for watchdog oscillator if selected. In addition all analog blocks and the flash are shut down. In Power-down mode, the application can keep the BOD circuit running for BOD protection.

The LPC11U2x can wake up from Power-down mode via reset, selected GPIO pins, a watchdog timer interrupt, or an interrupt generating USB port activity.

Power-down mode reduces power consumption compared to Deep-sleep mode at the expense of longer wake-up times.

7.17.5.5 Deep power-down mode

In Deep power-down mode, power is shut off to the entire chip except for the WAKEUP pin. The LPC11U2x can wake up from Deep power-down mode via the WAKEUP pin.

The LPC11U2x can be prevented from entering Deep power-down mode by setting a lock bit in the PMU block. Locking out Deep power-down mode enables the application to keep the watchdog timer or the BOD running at all times.

When entering Deep power-down mode, an external pull-up resistor is required on the WAKEUP pin to hold it HIGH. Pull the $\overline{\text{RESET}}$ pin HIGH to prevent it from floating while in Deep power-down mode.

7.17.6 System control

7.17.6.1 Reset

Reset has four sources on the LPC11U2x: the $\overline{\text{RESET}}$ pin, the Watchdog reset, power-on reset (POR), and the BrownOut Detection (BOD) circuit. The $\overline{\text{RESET}}$ pin is a Schmitt trigger input pin. Assertion of chip reset by any source, once the operating voltage attains a usable level, starts the IRC and initializes the flash controller.

A LOW-going pulse as short as 50 ns resets the part.

When the internal Reset is removed, the processor begins executing at address 0, which is initially the Reset vector mapped from the boot block. At that point, all of the processor and peripheral registers have been initialized to predetermined values.

In Deep power-down mode, an external pull-up resistor is required on the $\overline{\text{RESET}}$ pin.

7.17.6.2 Brownout detection

The LPC11U2x includes four levels for monitoring the voltage on the V_{DD} pin. If this voltage falls below one of the four selected levels, the BOD asserts an interrupt signal to the NVIC. This signal can be enabled for interrupt in the Interrupt Enable Register in the NVIC to cause a CPU interrupt. Alternatively, software can monitor the signal by reading a dedicated status register. Four additional threshold levels can be selected to cause a forced reset of the chip.

7.17.6.3 Code security (Code Read Protection - CRP)

CRP provides different levels of security in the system so that access to the on-chip flash and use of the Serial Wire Debugger (SWD) and In-System Programming (ISP) can be restricted. Programming a specific pattern into a dedicated flash location invokes CRP. IAP commands are not affected by the CRP.

In addition, ISP entry via the PIO0_1 pin can be disabled without enabling CRP. For details, see the *LPC11Uxx user manual*.

There are three levels of Code Read Protection:

1. CRP1 disables access to the chip via the SWD and allows partial flash update (excluding flash sector 0) using a limited set of the ISP commands. This mode is useful when CRP is required and flash field updates are needed but all sectors cannot be erased.
2. CRP2 disables access to the chip via the SWD and only allows full flash erase and update using a reduced set of the ISP commands.
3. Running an application with level CRP3 selected, fully disables any access to the chip via the SWD pins and the ISP. This mode effectively disables ISP override using PIO0_1 pin as well. If necessary, the application must provide a flash update mechanism using IAP calls or using a call to the reinvoke ISP command to enable flash update via the USART.

CAUTION

If level three Code Read Protection (CRP3) is selected, no future factory testing can be performed on the device.

In addition to the three CRP levels, sampling of pin PIO0_1 for valid user code can be disabled. For details, see the *LPC11Uxx user manual*.

7.17.6.4 APB interface

The APB peripherals are located on one APB bus.

7.17.6.5 AHBLite

The AHBLite connects the CPU bus of the ARM Cortex-M0 to the flash memory, the main static RAM, and the ROM.

7.17.6.6 External interrupt inputs

All GPIO pins can be level or edge sensitive interrupt inputs.

7.18 Emulation and debugging

Debug functions are integrated into the ARM Cortex-M0. Serial wire debug functions are supported in addition to a standard JTAG boundary scan. The ARM Cortex-M0 is configured to support up to four breakpoints and two watch points.

The $\overline{\text{RESET}}$ pin selects between the JTAG boundary scan ($\overline{\text{RESET}} = \text{LOW}$) and the ARM SWD debug ($\overline{\text{RESET}} = \text{HIGH}$). The ARM SWD debug port is disabled while the LPC11U2x is in reset.

To perform boundary scan testing, follow these steps:

1. Erase any user code residing in flash.
2. Power up the part with the $\overline{\text{RESET}}$ pin pulled HIGH externally.
3. Wait for at least 250 μs .
4. Pull the $\overline{\text{RESET}}$ pin LOW externally.
5. Perform boundary scan operations.
6. Once the boundary scan operations are completed, assert the $\overline{\text{TRST}}$ pin to enable the SWD debug mode, and release the $\overline{\text{RESET}}$ pin (pull HIGH).

Remark: The JTAG interface cannot be used for debug purposes.

8. Limiting values

Table 4. Limiting values

In accordance with the Absolute Maximum Rating System (IEC 60134).^[1]

Symbol	Parameter	Conditions	Min	Max	Unit
V _{DD}	supply voltage (core and external rail)		-0.5	+4.6	V
V _I	input voltage	5 V tolerant digital I/O pins; V _{DD} ≥ 1.8 V	-0.5	+5.5	V
		V _{DD} = 0 V	-0.5	+3.6	V
		5 V tolerant open-drain pins PIO0_4 and PIO0_5	-0.5	+5.5	
V _{IA}	analog input voltage	pin configured as analog input	-0.5	4.6	V
I _{DD}	supply current	per supply pin	-	100	mA
I _{SS}	ground current	per ground pin	-	100	mA
I _{latch}	I/O latch-up current	-(0.5V _{DD}) < V _I < (1.5V _{DD}); T _j < 125 °C	-	100	mA
T _{stg}	storage temperature	non-operating	-65	+150	°C
T _{j(max)}	maximum junction temperature		-	150	°C
P _{tot(pack)}	total power dissipation (per package)	based on package heat transfer, not device power consumption	-	1.5	W
V _{ESD}	electrostatic discharge voltage	human body model; all pins	-	+6500	V

[1] The following applies to the limiting values:

- a) This product includes circuitry specifically designed for the protection of its internal devices from the damaging effects of excessive static charge. Nonetheless, it is suggested that conventional precautions be taken to avoid applying greater than the rated maximum.
 - b) Parameters are valid over operating temperature range unless otherwise specified. All voltages are with respect to V_{SS} unless otherwise noted.
 - c) The limiting values are stress ratings only. Operating the part at these values is not recommended, and proper operation is not guaranteed. The conditions for functional operation are specified in [Table 5](#).
- [2] Maximum/minimum voltage above the maximum operating voltage (see [Table 5](#)) and below ground that can be applied for a short time (< 10 ms) to a device without leading to irrecoverable failure. Failure includes the loss of reliability and shorter lifetime of the device.
- [3] See [Table 6](#) for maximum operating voltage.
- [4] V_{DD} present or not present. Compliant with the I²C-bus standard. 5.5 V can be applied to this pin when V_{DD} is powered down.
- [5] Including voltage on outputs in 3-state mode.
- [6] The maximum non-operating storage temperature is different than the temperature for required shelf life which should be determined based on required shelf lifetime. Please refer to the JEDEC spec (J-STD-033B.1) for further details.
- [7] Human body model: equivalent to discharging a 100 pF capacitor through a 1.5 kΩ series resistor.

9. Static characteristics

Table 5. Static characteristics

$T_{amb} = -40\text{ °C}$ to $+85\text{ °C}$, unless otherwise specified.

Symbol	Parameter	Conditions	Min	Typ ^[1]	Max	Unit	
V _{DD}	supply voltage (core and external rail)	[2]	1.8	3.3	3.6	V	
I _{DD}	supply current	Active mode; V _{DD} = 3.3 V; T _{amb} = 25 °C; code while(1){} executed from flash;					
		system clock = 12 MHz	[3][4][5] [6][7][8]	-	2	-	mA
		system clock = 50 MHz	[4][5][6] [7][8][9]	-	7	-	mA
		Sleep mode; V _{DD} = 3.3 V; T _{amb} = 25 °C; system clock = 12 MHz	[3][4][5] [6][7][8]	-	1	-	mA
		Deep-sleep mode; V _{DD} = 3.3 V; T _{amb} = 25 °C	[4][7]	-	360	-	µA
		Power-down mode; V _{DD} = 3.3 V; T _{amb} = 25 °C		-	2	-	µA
		Deep power-down mode; V _{DD} = 3.3 V; T _{amb} = 25 °C	[10]	-	220	-	nA
Standard port pins, RESET							
I _{IL}	LOW-level input current	V _I = 0 V; on-chip pull-up resistor disabled	-	0.5	10	nA	
I _{IH}	HIGH-level input current	V _I = V _{DD} ; on-chip pull-down resistor disabled	-	0.5	10	nA	
I _{OZ}	OFF-state output current	V _O = 0 V; V _O = V _{DD} ; on-chip pull-up/down resistors disabled	-	0.5	10	nA	
V _I	input voltage	pin configured to provide a digital function	[11][12] [13]	0	-	5.0	V
V _O	output voltage	output active	0	-	V _{DD}	V	
V _{IH}	HIGH-level input voltage		0.7V _{DD}	-	-	V	
V _{IL}	LOW-level input voltage		-	-	0.3V _{DD}	V	
V _{hys}	hysteresis voltage		-	0.4	-	V	
V _{OH}	HIGH-level output voltage	2.0 V ≤ V _{DD} ≤ 3.6 V; I _{OH} = -4 mA	V _{DD} - 0.4	-	-	V	
		1.8 V ≤ V _{DD} < 2.0 V; I _{OH} = -3 mA	V _{DD} - 0.4	-	-	V	
V _{OL}	LOW-level output voltage	2.0 V ≤ V _{DD} ≤ 3.6 V; I _{OL} = 4 mA	-	-	0.4	V	
		1.8 V ≤ V _{DD} < 2.0 V; I _{OL} = 3 mA	-	-	0.4	V	
I _{OH}	HIGH-level output current	V _{OH} = V _{DD} - 0.4 V; 2.0 V ≤ V _{DD} ≤ 3.6 V	-4	-	-	mA	
		1.8 V ≤ V _{DD} < 2.0 V	-3	-	-	mA	

Table 5. Static characteristics ...continued
T_{amb} = -40 °C to +85 °C, unless otherwise specified.

Symbol	Parameter	Conditions	Min	Typ ^[1]	Max	Unit
I _{OL}	LOW-level output current	V _{OL} = 0.4 V 2.0 V ≤ V _{DD} ≤ 3.6 V	4	-	-	mA
		1.8 V ≤ V _{DD} < 2.0 V	3	-	-	mA
I _{OHS}	HIGH-level short-circuit output current	V _{OH} = 0 V ^[14]	-	-	-45	mA
I _{OLS}	LOW-level short-circuit output current	V _{OL} = V _{DD} ^[14]	-	-	50	mA
I _{pd}	pull-down current	V _I = 5 V	10	50	150	μA
I _{pu}	pull-up current	V _I = 0 V; 2.0 V ≤ V _{DD} ≤ 3.6 V	-15	-50	-85	μA
		1.8 V ≤ V _{DD} < 2.0 V	-10	-50	-85	μA
		V _{DD} < V _I < 5 V	0	0	0	μA
High-drive output pin (PIO0_7)						
I _{IL}	LOW-level input current	V _I = 0 V; on-chip pull-up resistor disabled	-	0.5	10	nA
I _{IH}	HIGH-level input current	V _I = V _{DD} ; on-chip pull-down resistor disabled	-	0.5	10	nA
I _{OZ}	OFF-state output current	V _O = 0 V; V _O = V _{DD} ; on-chip pull-up/down resistors disabled	-	0.5	10	nA
V _I	input voltage	pin configured to provide a digital function ^{[11][12][13]}	0	-	5.0	V
V _O	output voltage	output active	0	-	V _{DD}	V
V _{IH}	HIGH-level input voltage		0.7V _{DD}	-	-	V
V _{IL}	LOW-level input voltage		-	-	0.3V _{DD}	V
V _{hys}	hysteresis voltage		0.4	-	-	V
V _{OH}	HIGH-level output voltage	2.5 V ≤ V _{DD} ≤ 3.6 V; I _{OH} = -20 mA	V _{DD} - 0.4	-	-	V
		1.8 V ≤ V _{DD} < 2.5 V; I _{OH} = -12 mA	V _{DD} - 0.4	-	-	V
V _{OL}	LOW-level output voltage	2.0 V ≤ V _{DD} ≤ 3.6 V; I _{OL} = 4 mA	-	-	0.4	V
		1.8 V ≤ V _{DD} < 2.0 V; I _{OL} = 3 mA	-	-	0.4	V
I _{OH}	HIGH-level output current	V _{OH} = V _{DD} - 0.4 V; 2.5 V ≤ V _{DD} ≤ 3.6 V	20	-	-	mA
		1.8 V ≤ V _{DD} < 2.5 V	12	-	-	mA
I _{OL}	LOW-level output current	V _{OL} = 0.4 V 2.0 V ≤ V _{DD} ≤ 3.6 V	4	-	-	mA
		1.8 V ≤ V _{DD} < 2.0 V	3	-	-	mA
I _{OLS}	LOW-level short-circuit output current	V _{OL} = V _{DD} ^[14]	-	-	50	mA
I _{pd}	pull-down current	V _I = 5 V	10	50	150	μA
I _{pu}	pull-up current	V _I = 0 V 2.0 V ≤ V _{DD} ≤ 3.6 V	-15	-50	-85	μA
		1.8 V ≤ V _{DD} < 2.0 V	-10	-50	-85	μA
		V _{DD} < V _I < 5 V	0	0	0	μA

Table 5. Static characteristics ...continued
 $T_{amb} = -40\text{ }^{\circ}\text{C}$ to $+85\text{ }^{\circ}\text{C}$, unless otherwise specified.

Symbol	Parameter	Conditions	Min	Typ ^[1]	Max	Unit
I²C-bus pins (PIO0_4 and PIO0_5)						
V _{IH}	HIGH-level input voltage		0.7V _{DD}	-	-	V
V _{IL}	LOW-level input voltage		-	-	0.3V _{DD}	V
V _{hys}	hysteresis voltage		-	0.05V _{DD}	-	V
I _{OL}	LOW-level output current	V _{OL} = 0.4 V; I ² C-bus pins configured as standard mode pins 2.0 V ≤ V _{DD} ≤ 3.6 V	3.5	-	-	mA
		1.8 V ≤ V _{DD} < 2.0 V	3	-	-	
I _{OL}	LOW-level output current	V _{OL} = 0.4 V; I ² C-bus pins configured as Fast-mode Plus pins 2.0 V ≤ V _{DD} ≤ 3.6 V	20	-	-	mA
		1.8 V ≤ V _{DD} < 2.0 V	16	-	-	
I _{LI}	input leakage current	V _I = V _{DD} ^[15]	-	2	4	μA
		V _I = 5 V	-	10	22	μA
Oscillator pins						
V _{i(xtal)}	crystal input voltage		-0.5	1.8	1.95	V
V _{o(xtal)}	crystal output voltage		-0.5	1.8	1.95	V
USB pins						
I _{OZ}	OFF-state output current	0 V < V _I < 3.3 V ^[2]	-	-	±10	μA
V _{BUS}	bus supply voltage	^[2]	-	-	5.25	V
V _{DI}	differential input sensitivity voltage	(D+) - (D-) ^[2]	0.2	-	-	V
V _{CM}	differential common mode voltage range	includes V _{DI} range ^[2]	0.8	-	2.5	V
V _{th(rs)se}	single-ended receiver switching threshold voltage	^[2]	0.8	-	2.0	V
V _{OL}	LOW-level output voltage	for low-/full-speed; R _L of 1.5 kΩ to 3.6 V ^[2]	-	-	0.18	V
V _{OH}	HIGH-level output voltage	driven; for low-/full-speed; R _L of 15 kΩ to GND ^[2]	2.8	-	3.5	V
C _{trans}	transceiver capacitance	pin to GND ^[2]	-	-	20	pF
Z _{DRV}	driver output impedance for driver which is not high-speed capable	with 33 Ω series resistor; steady state drive ^{[16][2]}	36	-	44.1	Ω

Table 5. Static characteristics ...continued
 $T_{amb} = -40\text{ }^{\circ}\text{C}$ to $+85\text{ }^{\circ}\text{C}$, unless otherwise specified.

Symbol	Parameter	Conditions	Min	Typ ^[1]	Max	Unit
Pin capacitance						
C _{io}	input/output capacitance	pins configured for analog function	-	-	7.1	pF
		I ² C-bus pins (PIO0_4 and PIO0_5)	-	-	2.5	pF
		pins configured as GPIO	-	-	2.8	pF

- [1] Typical ratings are not guaranteed. The values listed are at room temperature (25 °C), nominal supply voltages.
- [2] For USB operation $3.0\text{ V} \leq V_{DD} \leq 3.6\text{ V}$. Guaranteed by design.
- [3] IRC enabled; system oscillator disabled; system PLL disabled.
- [4] I_{DD} measurements were performed with all pins configured as GPIO outputs driven LOW and pull-up resistors disabled.
- [5] BOD disabled.
- [6] All peripherals disabled in the AHBCLKCTRL register. Peripheral clocks to USART, SSP0/1 disabled in the SYSCON block.
- [7] USB_DP and USB_DM pulled LOW externally.
- [8] Low-current mode PWR_LOW_CURRENT selected when running the set_power routine in the power profiles.
- [9] IRC disabled; system oscillator enabled; system PLL enabled.
- [10] WAKEUP pin pulled HIGH externally. An external pull-up resistor is required on the $\overline{\text{RESET}}$ pin for the Deep power-down mode.
- [11] Including voltage on outputs in 3-state mode.
- [12] V_{DD} supply voltage must be present.
- [13] 3-state outputs go into 3-state mode in Deep power-down mode.
- [14] Allowed as long as the current limit does not exceed the maximum current allowed by the device.
- [15] To V_{SS}.
- [16] Includes external resistors of $33\ \Omega \pm 1\%$ on USB_DP and USB_DM.

Table 6. ADC static characteristics

$T_{amb} = -40\text{ }^{\circ}\text{C}$ to $+85\text{ }^{\circ}\text{C}$ unless otherwise specified; ADC frequency 4.5 MHz, $V_{DD} = 2.5\text{ V}$ to 3.6 V .

Symbol	Parameter	Conditions	Min	Typ	Max	Unit
V_{IA}	analog input voltage		0	-	V_{DD}	V
C_{ia}	analog input capacitance		-	-	1	pF
E_D	differential linearity error	[1][2]	-	-	± 1	LSB
$E_{L(adj)}$	integral non-linearity	[3]	-	-	± 1.5	LSB
E_O	offset error	[4]	-	-	± 3.5	LSB
E_G	gain error	[5]	-	-	0.6	%
E_T	absolute error	[6]	-	-	± 4	LSB
R_{vsi}	voltage source interface resistance		-	-	40	k Ω
R_i	input resistance	[7][8]	-	-	2.5	M Ω

[1] The ADC is monotonic, there are no missing codes.

[2] The differential linearity error (E_D) is the difference between the actual step width and the ideal step width. See [Figure 8](#).

[3] The integral non-linearity ($E_{L(adj)}$) is the peak difference between the center of the steps of the actual and the ideal transfer curve after appropriate adjustment of gain and offset errors. See [Figure 8](#).

[4] The offset error (E_O) is the absolute difference between the straight line which fits the actual curve and the straight line which fits the ideal curve. See [Figure 8](#).

[5] The gain error (E_G) is the relative difference in percent between the straight line fitting the actual transfer curve after removing offset error, and the straight line which fits the ideal transfer curve. See [Figure 8](#).

[6] The absolute error (E_T) is the maximum difference between the center of the steps of the actual transfer curve of the non-calibrated ADC and the ideal transfer curve. See [Figure 8](#).

[7] $T_{amb} = 25\text{ }^{\circ}\text{C}$; maximum sampling frequency $f_s = 400\text{ kSamples/s}$ and analog input capacitance $C_{ia} = 1\text{ pF}$.

[8] Input resistance R_i depends on the sampling frequency f_s : $R_i = 1 / (f_s \times C_{ia})$.

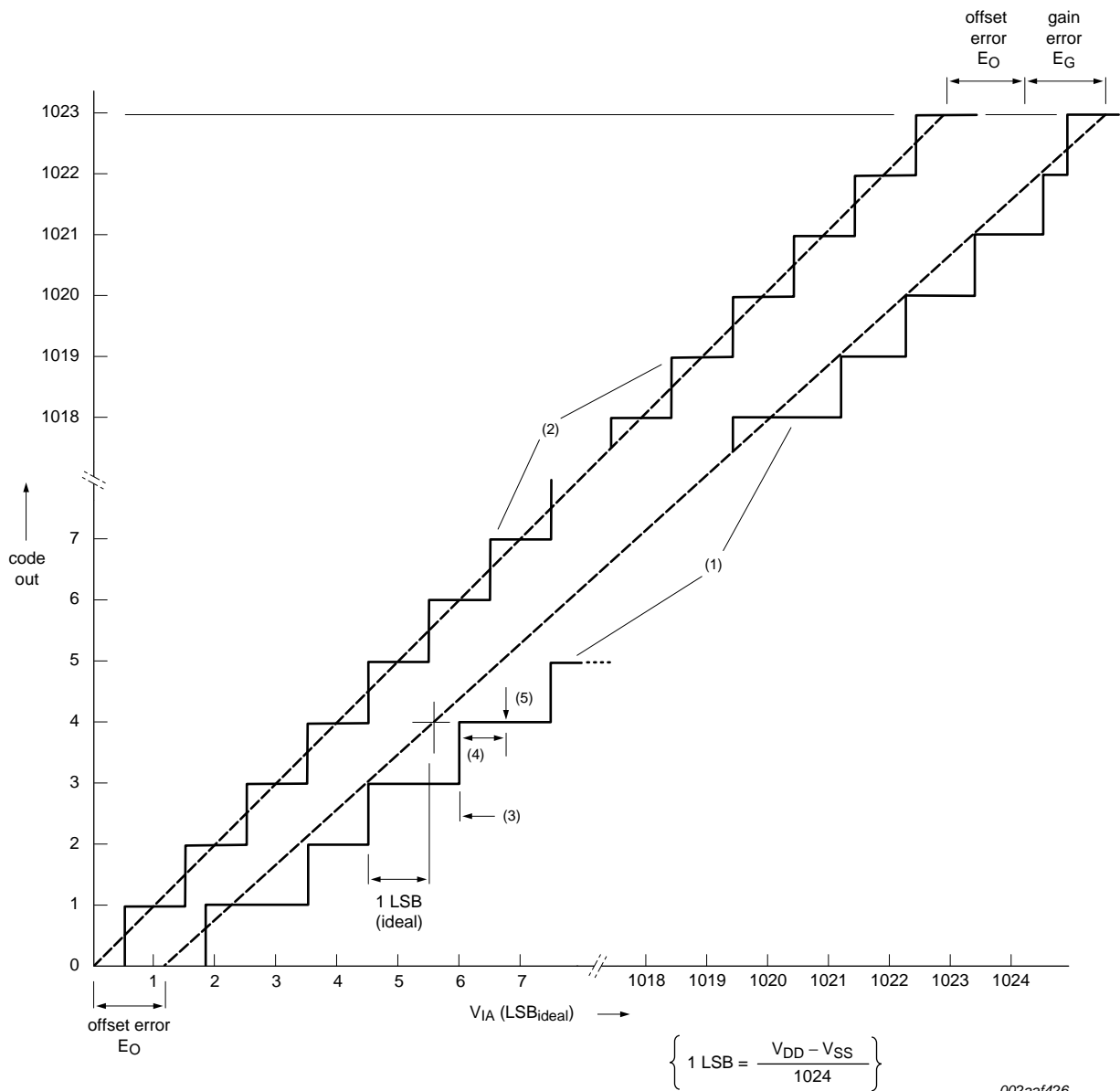

002aaf426

- (1) Example of an actual transfer curve.
- (2) The ideal transfer curve.
- (3) Differential linearity error (E_D).
- (4) Integral non-linearity (E_{L(adj)}).
- (5) Center of a step of the actual transfer curve.

Fig 8. ADC characteristics

9.1 BOD static characteristics

Table 7. BOD static characteristics^[1]

$T_{amb} = 25\text{ }^{\circ}\text{C}$.

Symbol	Parameter	Conditions	Min	Typ	Max	Unit
V_{th}	threshold voltage	interrupt level 1				
		assertion	-	2.22	-	V
		de-assertion	-	2.35	-	V
		interrupt level 2				
		assertion	-	2.52	-	V
		de-assertion	-	2.66	-	V
		interrupt level 3				
		assertion	-	2.80	-	V
		de-assertion	-	2.90	-	V
		reset level 0				
		assertion	-	1.46	-	V
		de-assertion	-	1.63	-	V
		reset level 1				
		assertion	-	2.06	-	V
		de-assertion	-	2.15	-	V
		reset level 2				
		assertion	-	2.35	-	V
		de-assertion	-	2.43	-	V
		reset level 3				
		assertion	-	2.63	-	V
de-assertion	-	2.71	-	V		

[1] Interrupt levels are selected by writing the level value to the BOD control register BODCTRL, see *the LPC11Uxx user manual*.

9.2 Power consumption

Power measurements in Active, Sleep, and Deep-sleep modes were performed under the following conditions (see the *LPC11Uxx user manual*):

- Configure all pins as GPIO with pull-up resistor disabled in the IOCON block.
- Configure GPIO pins as outputs using the GPIODIR registers.
- Write 0 to all GPIODATA registers to drive the outputs LOW.





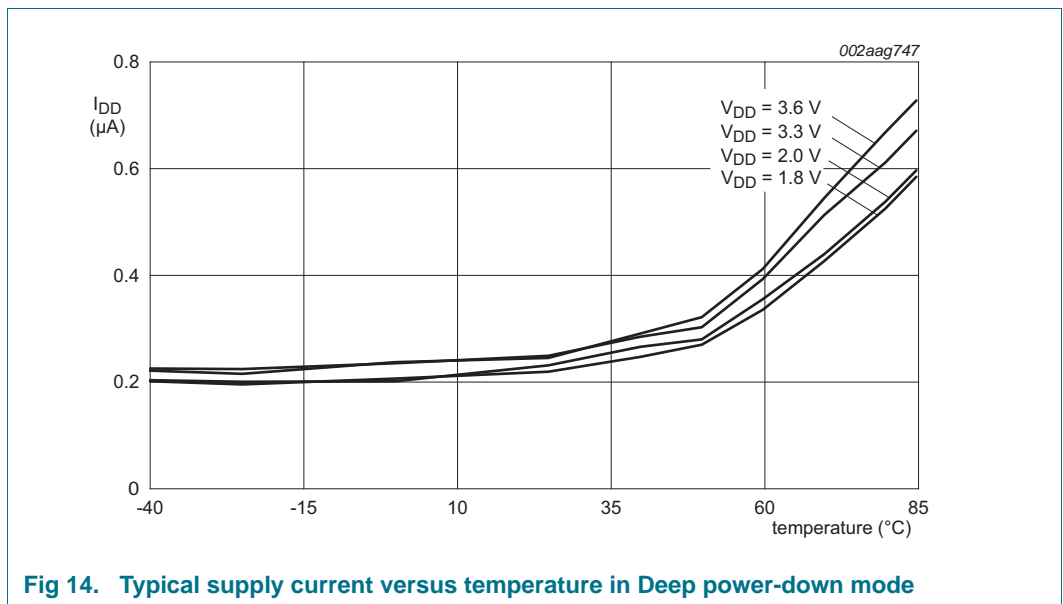

9.3 Peripheral power consumption

The supply current per peripheral is measured as the difference in supply current between the peripheral block enabled and the peripheral block disabled in the SYSAHBCLKCFG and PDRUNCFG (for analog blocks) registers. All other blocks are disabled in both registers and no code is executed. Measured on a typical sample at $T_{amb} = 25\text{ }^{\circ}\text{C}$. Unless noted otherwise, the system oscillator and PLL are running in both measurements.

The supply currents are shown for system clock frequencies of 12 MHz and 48 MHz.

Table 8. Power consumption for individual analog and digital blocks

Peripheral	Typical supply current in mA			Notes
	n/a	12 MHz	48 MHz	
IRC	0.27	-	-	System oscillator running; PLL off; independent of main clock frequency.
System oscillator at 12 MHz	0.22	-	-	IRC running; PLL off; independent of main clock frequency.
Watchdog oscillator at 500 kHz/2	0.004	-	-	System oscillator running; PLL off; independent of main clock frequency.
BOD	0.051	-	-	Independent of main clock frequency.
Main PLL	-	0.21	-	-
ADC	-	0.08	0.29	-
CLKOUT	-	0.12	0.47	Main clock divided by 4 in the CLKOUTDIV register.
CT16B0	-	0.02	0.06	-
CT16B1	-	0.02	0.06	-
CT32B0	-	0.02	0.07	-
CT32B1	-	0.02	0.06	-
GPIO	-	0.23	0.88	GPIO pins configured as outputs and set to LOW. Direction and pin state are maintained if the GPIO is disabled in the SYSAHBCLKCFG register.
IOCONFIG	-	0.03	0.10	-
I2C	-	0.04	0.13	-
ROM	-	0.04	0.15	-
SPI0	-	0.12	0.45	-
SPI1	-	0.12	0.45	-
UART	-	0.22	0.82	-
WWDT	-	0.02	0.06	Main clock selected as clock source for the WDT.
USB	-	-	1.2	-

9.4 Electrical pin characteristics

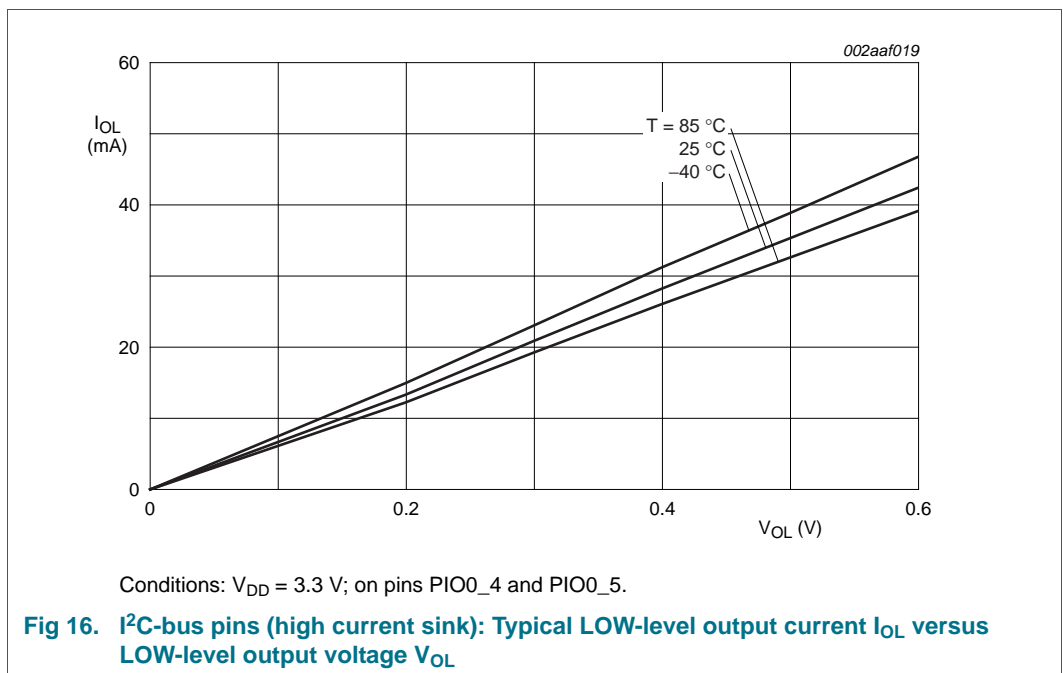
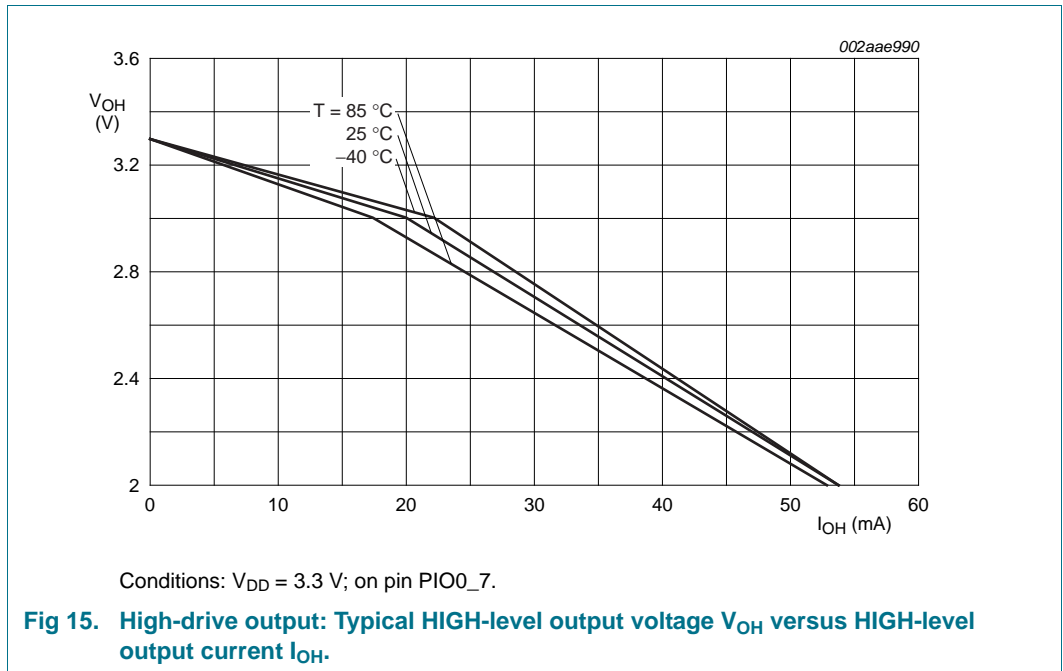





10. Dynamic characteristics

10.1 Flash memory

Table 9. Flash characteristics

$T_{amb} = -40\text{ °C to }+85\text{ °C}$, unless otherwise specified.

Symbol	Parameter	Conditions	Min	Typ	Max	Unit
N_{endu}	endurance		10000	100000	-	cycles
t_{ret}	retention time	powered	10	-	-	years
		unpowered	20	-	-	years
t_{er}	erase time	sector or multiple consecutive sectors	95	100	105	ms
t_{prog}	programming time		0.95	1	1.05	ms

[1] Number of program/erase cycles.

[2] Programming times are given for writing 256 bytes from RAM to the flash. Data must be written to the flash in blocks of 256 bytes.

Table 10. EEPROM characteristics

$T_{amb} = -40\text{ °C to }+85\text{ °C}$; $V_{DD} = 2.7\text{ V to }3.6\text{ V}$. Based on JEDEC NVM qualification. Failure rate < 10 ppm for parts as specified below.

Symbol	Parameter	Conditions	Min	Typ	Max	Unit
N_{endu}	endurance		100000	1000000	-	cycles
t_{ret}	retention time	powered	100	200	-	years
		unpowered	150	300	-	years
t_{prog}	programming time	64 bytes	-	2.9	-	ms

10.2 External clock

Table 11. Dynamic characteristic: external clock

$T_{amb} = -40\text{ °C to }+85\text{ °C}$; V_{DD} over specified ranges.^[1]

Symbol	Parameter	Conditions	Min	Typ ^[2]	Max	Unit
f_{osc}	oscillator frequency		1	-	25	MHz
$T_{cy(clk)}$	clock cycle time		40	-	1000	ns
t_{CHCX}	clock HIGH time		$T_{cy(clk)} \times 0.4$	-	-	ns
t_{CLCX}	clock LOW time		$T_{cy(clk)} \times 0.4$	-	-	ns
t_{CLCH}	clock rise time		-	-	5	ns
t_{CHCL}	clock fall time		-	-	5	ns

[1] Parameters are valid over operating temperature range unless otherwise specified.

[2] Typical ratings are not guaranteed. The values listed are at room temperature (25 °C), nominal supply voltages.

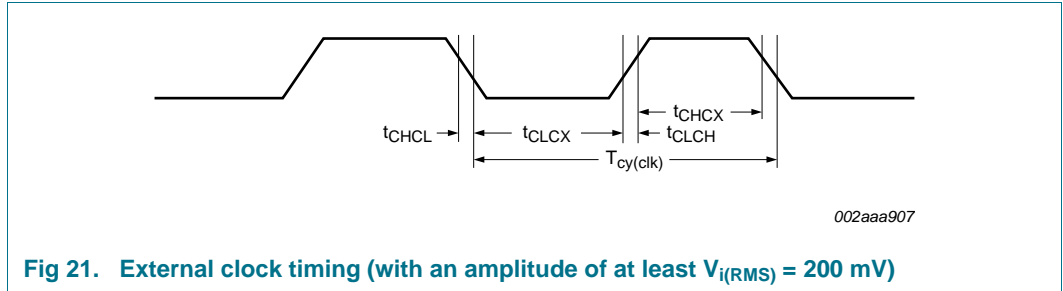

10.3 Internal oscillators

Table 12. Dynamic characteristics: IRC

$T_{amb} = -40\text{ }^{\circ}\text{C}$ to $+85\text{ }^{\circ}\text{C}$; $2.7\text{ V} \leq V_{DD} \leq 3.6\text{ V}$ [1].

Symbol	Parameter	Conditions	Min	Typ[2]	Max	Unit
$f_{osc(RC)}$	internal RC oscillator frequency	-	11.88	12	12.12	MHz

[1] Parameters are valid over operating temperature range unless otherwise specified.

[2] Typical ratings are not guaranteed. The values listed are at room temperature ($25\text{ }^{\circ}\text{C}$), nominal supply voltages.

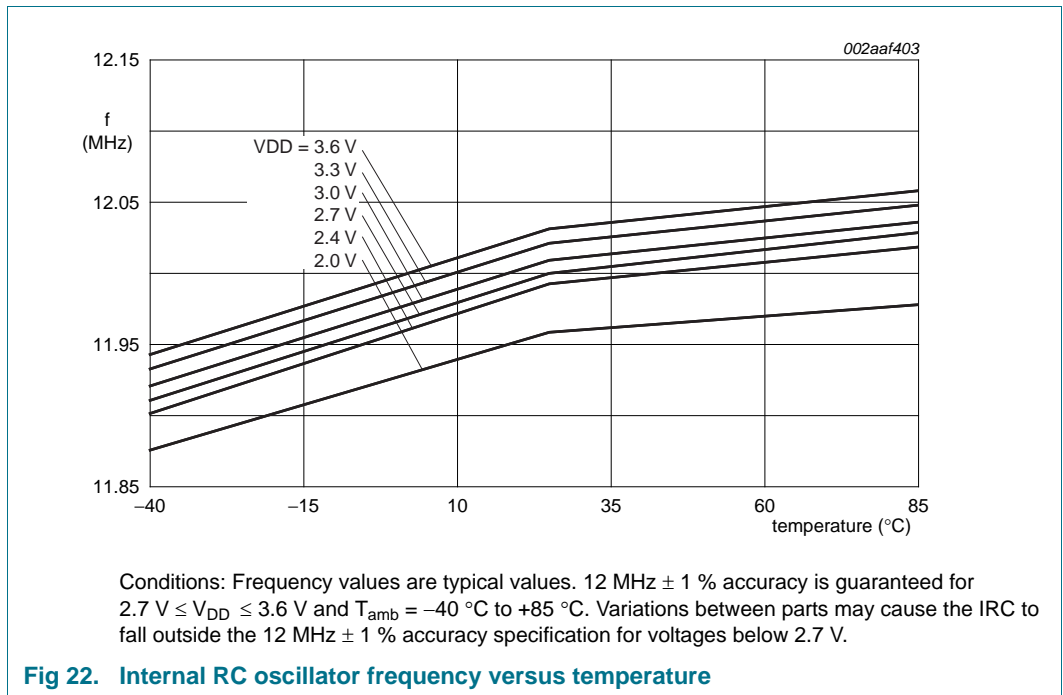

Table 13. Dynamic characteristics: Watchdog oscillator

Symbol	Parameter	Conditions	Min	Typ[1]	Max	Unit
$f_{osc(int)}$	internal oscillator frequency	DIVSEL = 0x1F, FREQSEL = 0x1 in the WDTOSCCTRL register; [2][3]	-	7.8	-	kHz
		DIVSEL = 0x00, FREQSEL = 0xF in the WDTOSCCTRL register [2][3]	-	1700	-	kHz

[1] Typical ratings are not guaranteed. The values listed are at nominal supply voltages.

- [2] The typical frequency spread over processing and temperature ($T_{amb} = -40\text{ }^{\circ}\text{C}$ to $+85\text{ }^{\circ}\text{C}$) is $\pm 40\%$.
- [3] See the *LPC11Uxx user manual*.

10.4 I/O pins

Table 14. Dynamic characteristics: I/O pins^[1]

$T_{amb} = -40\text{ }^{\circ}\text{C}$ to $+85\text{ }^{\circ}\text{C}$; $3.0\text{ V} \leq V_{DD} \leq 3.6\text{ V}$.

Symbol	Parameter	Conditions	Min	Typ	Max	Unit
t_r	rise time	pin configured as output	3.0	-	5.0	ns
t_f	fall time	pin configured as output	2.5	-	5.0	ns

- [1] Applies to standard port pins and $\overline{\text{RESET}}$ pin.

10.5 I²C-bus

Table 15. Dynamic characteristic: I²C-bus pins^[1]

$T_{amb} = -40\text{ }^{\circ}\text{C}$ to $+85\text{ }^{\circ}\text{C}$.^[2]

Symbol	Parameter	Conditions	Min	Max	Unit
f_{SCL}	SCL clock frequency	Standard-mode	0	100	kHz
		Fast-mode	0	400	kHz
		Fast-mode Plus	0	1	MHz
t_f	fall time ^{[3][4][5][6]}	of both SDA and SCL signals	-	300	ns
		Standard-mode			
		Fast-mode	$20 + 0.1 \times C_b$	300	ns
t_{LOW}	LOW period of the SCL clock	Standard-mode	4.7	-	μs
		Fast-mode	1.3	-	μs
		Fast-mode Plus	0.5	-	μs
t_{HIGH}	HIGH period of the SCL clock	Standard-mode	4.0	-	μs
		Fast-mode	0.6	-	μs
		Fast-mode Plus	0.26	-	μs
$t_{\text{HD,DAT}}$	data hold time ^{[3][7][8]}	Standard-mode	0	-	μs
		Fast-mode	0	-	μs
		Fast-mode Plus	0	-	μs
$t_{\text{SU,DAT}}$	data set-up time ^{[9][10]}	Standard-mode	250	-	ns
		Fast-mode	100	-	ns
		Fast-mode Plus	50	-	ns

- [1] See the I²C-bus specification *UM10204* for details.
- [2] Parameters are valid over operating temperature range unless otherwise specified.
- [3] A device must internally provide a hold time of at least 300 ns for the SDA signal (with respect to the $V_{\text{IH}}(\text{min})$ of the SCL signal) to bridge the undefined region of the falling edge of SCL.
- [4] C_b = total capacitance of one bus line in pF.
- [5] The maximum t_f for the SDA and SCL bus lines is specified at 300 ns. The maximum fall time for the SDA output stage t_f is specified at 250 ns. This allows series protection resistors to be connected in between the SDA and the SCL pins and the SDA/SCL bus lines without exceeding the maximum specified t_f .
- [6] In Fast-mode Plus, fall time is specified the same for both output stage and bus timing. If series resistors are used, designers should allow for this when considering bus timing.

- [7] The maximum $t_{HD;DAT}$ could be 3.45 μ s and 0.9 μ s for Standard-mode and Fast-mode but must be less than the maximum of $t_{VD;DAT}$ or $t_{VD;ACK}$ by a transition time (see *UM10204*). This maximum must only be met if the device does not stretch the LOW period of the SCL signal. If the clock stretches the SCL, the data must be valid by the set-up time before it releases the clock.
- [8] $t_{HD;DAT}$ is the data hold time that is measured from the falling edge of SCL; applies to data in transmission and the acknowledge.
- [9] $t_{SU;DAT}$ is the data set-up time that is measured with respect to the rising edge of SCL; applies to data in transmission and the acknowledge.
- [10] A Fast-mode I²C-bus device can be used in a Standard-mode I²C-bus system but the requirement $t_{SU;DAT} = 250$ ns must then be met. This will automatically be the case if the device does not stretch the LOW period of the SCL signal. If such a device does stretch the LOW period of the SCL signal, it must output the next data bit to the SDA line $t_{r(max)} + t_{SU;DAT} = 1000 + 250 = 1250$ ns (according to the Standard-mode I²C-bus specification) before the SCL line is released. Also the acknowledge timing must meet this set-up time.

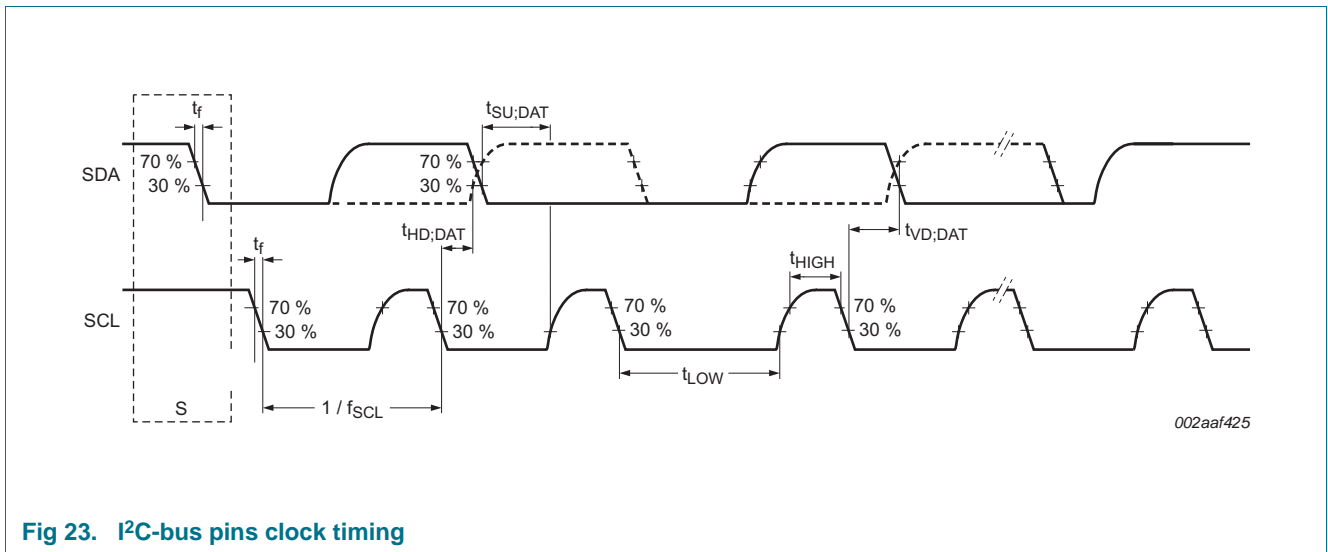

Fig 23. I²C-bus pins clock timing

10.6 SSP interface

Table 16. Dynamic characteristics of SPI pins in SPI mode

Symbol	Parameter	Conditions	Min	Typ	Max	Unit
SPI master (in SPI mode)						
T _{cy(clk)}	clock cycle time	full-duplex mode [1]	50	-	-	ns
		when only transmitting [1]	40	-	-	ns
t _{DS}	data set-up time	in SPI mode [2] 2.4 V ≤ V _{DD} ≤ 3.6 V	15	-	-	ns
		2.0 V ≤ V _{DD} < 2.4 V [2]	20	-	-	ns
		1.8 V ≤ V _{DD} < 2.0 V [2]	24	-	-	ns
t _{DH}	data hold time	in SPI mode [2]	0	-	-	ns
t _{v(Q)}	data output valid time	in SPI mode [2]	-	-	10	ns
t _{h(Q)}	data output hold time	in SPI mode [2]	0	-	-	ns
SPI slave (in SPI mode)						
T _{cy(PCLK)}	PCLK cycle time		20	-	-	ns
t _{DS}	data set-up time	in SPI mode [3][4]	0	-	-	ns
t _{DH}	data hold time	in SPI mode [3][4]	3 × T _{cy(PCLK)} + 4	-	-	ns
t _{v(Q)}	data output valid time	in SPI mode [3][4]	-	-	3 × T _{cy(PCLK)} + 11	ns
t _{h(Q)}	data output hold time	in SPI mode [3][4]	-	-	2 × T _{cy(PCLK)} + 5	ns

[1] $T_{cy(clk)} = (SSPCLKDIV \times (1 + SCR) \times CPSDVSR) / f_{main}$. The clock cycle time derived from the SPI bit rate $T_{cy(clk)}$ is a function of the main clock frequency f_{main} , the SPI peripheral clock divider (SSPCLKDIV), the SPI SCR parameter (specified in the SSP0CR0 register), and the SPI CPSDVSR parameter (specified in the SPI clock prescale register).

[2] $T_{amb} = -40\text{ }^{\circ}\text{C}$ to $85\text{ }^{\circ}\text{C}$.

[3] $T_{cy(clk)} = 12 \times T_{cy(PCLK)}$.

[4] $T_{amb} = 25\text{ }^{\circ}\text{C}$; for normal voltage supply range: $V_{DD} = 3.3\text{ V}$.



Fig 24. SSP master timing in SPI mode

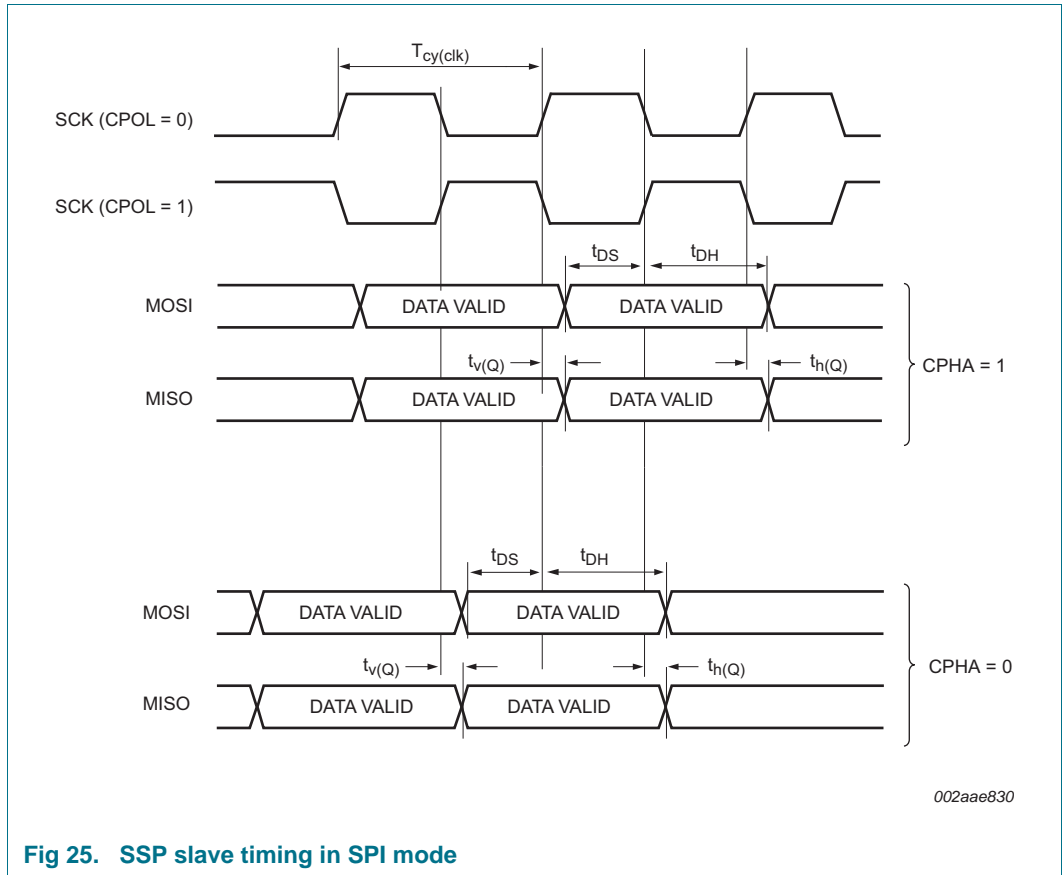

Fig 25. SSP slave timing in SPI mode

10.7 USB interface

Table 17. Dynamic characteristics: USB pins (full-speed)

$C_L = 50\text{ pF}$; $R_{pu} = 1.5\text{ k}\Omega$ on D+ to V_{DD} ; $3.0\text{ V} \leq V_{DD} \leq 3.6\text{ V}$.

Symbol	Parameter	Conditions	Min	Typ	Max	Unit
t_r	rise time	10 % to 90 %	8.5	-	13.8	ns
t_f	fall time	10 % to 90 %	7.7	-	13.7	ns
t_{FRFM}	differential rise and fall time matching	t_r / t_f	-	-	109	%
V_{CRS}	output signal crossover voltage		1.3	-	2.0	V
t_{FEOPT}	source SE0 interval of EOP	see Figure 26	160	-	175	ns
t_{FDEOP}	source jitter for differential transition to SE0 transition	see Figure 26	-2	-	+5	ns
t_{JR1}	receiver jitter to next transition		-18.5	-	+18.5	ns
t_{JR2}	receiver jitter for paired transitions	10 % to 90 %	-9	-	+9	ns
t_{EOPR}	EOP width at receiver	must accept as EOP; see Figure 26	82	-	-	ns

[1] Characterized but not implemented as production test. Guaranteed by design.

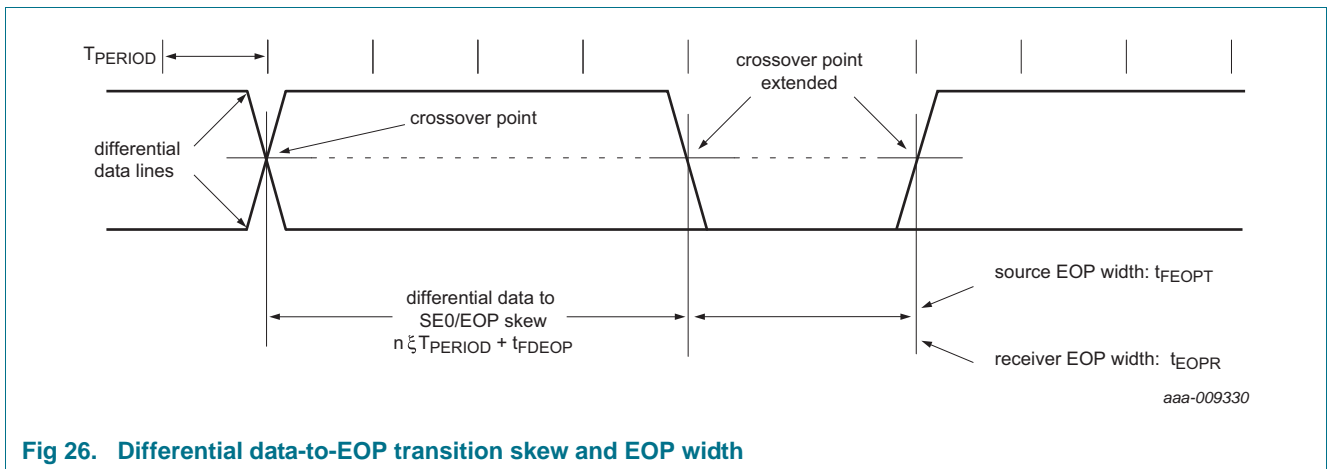

Fig 26. Differential data-to-EOP transition skew and EOP width

11. Application information

11.1 Suggested USB interface solutions

The USB device can be connected to the USB as self-powered device (see [Figure 27](#)) or bus-powered device (see [Figure 28](#)).

On the LPC11U2x, the PIO0_3/USB_VBUS pin is 5 V tolerant only when V_{DD} is applied and at operating voltage level. Therefore, if the USB_VBUS function is connected to the USB connector and the device is self-powered, the USB_VBUS pin must be protected for situations when $V_{DD} = 0$ V.

If V_{DD} is always at operating level while $VBUS = 5$ V, the USB_VBUS pin can be connected directly to the VBUS pin on the USB connector.

For systems where V_{DD} can be 0 V and VBUS is directly applied to the VBUS pin, precautions must be taken to reduce the voltage to below 3.6 V, which is the maximum allowable voltage on the USB_VBUS pin in this case.

One method is to use a voltage divider to connect the USB_VBUS pin to the VBUS on the USB connector. The voltage divider ratio should be such that the USB_VBUS pin will be greater than $0.7V_{DD}$ to indicate a logic HIGH while below the 3.6 V allowable maximum voltage.

For the following operating conditions

$$VBUS_{max} = 5.25 \text{ V}$$

$$V_{DD} = 3.6 \text{ V,}$$

the voltage divider should provide a reduction of $3.6 \text{ V}/5.25 \text{ V}$ or $\sim 0.686 \text{ V}$.

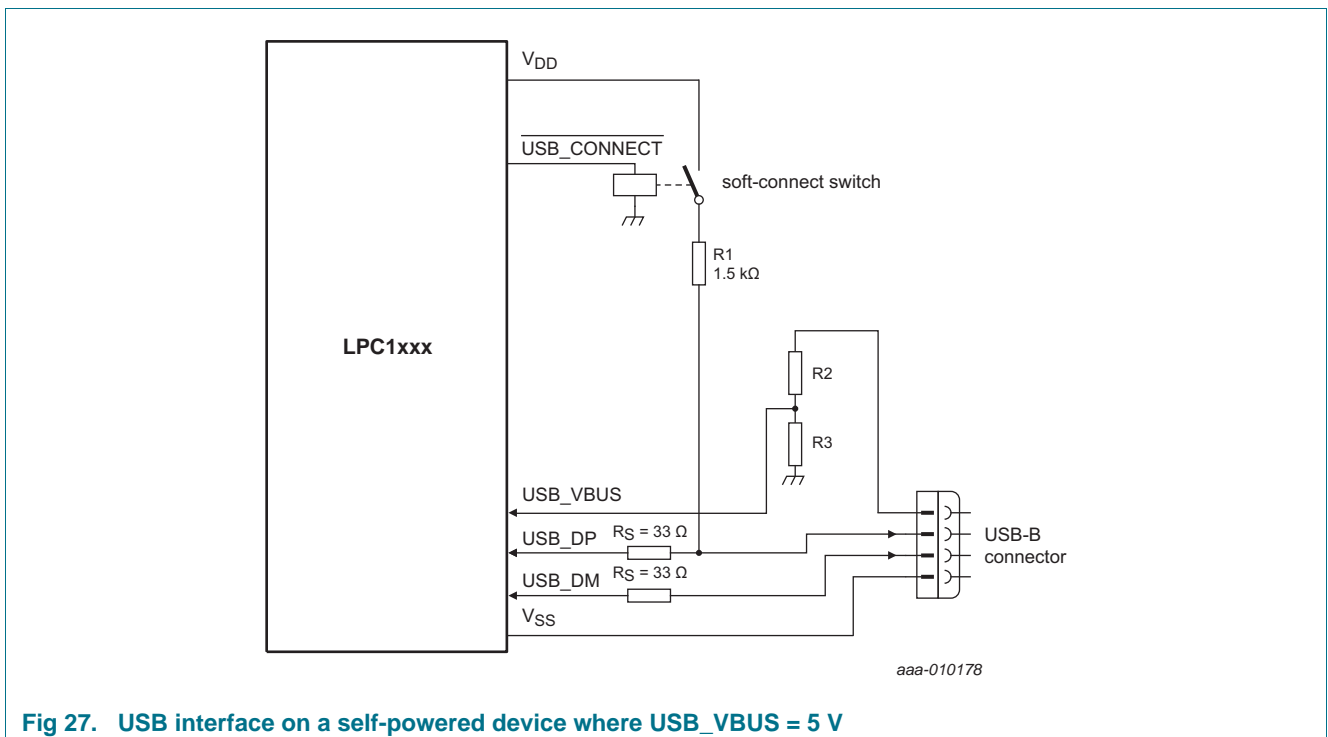

Fig 27. USB interface on a self-powered device where $USB_VBUS = 5$ V

For a bus-powered device, the VBUS signal does not need to be connected to the USB_VBUS pin (see [Figure 28](#)). The `USB_CONNECT` function can additionally be connected as shown in [Figure 27](#) to prevent the USB from timing out when there is a significant delay between power-up and handling USB traffic.

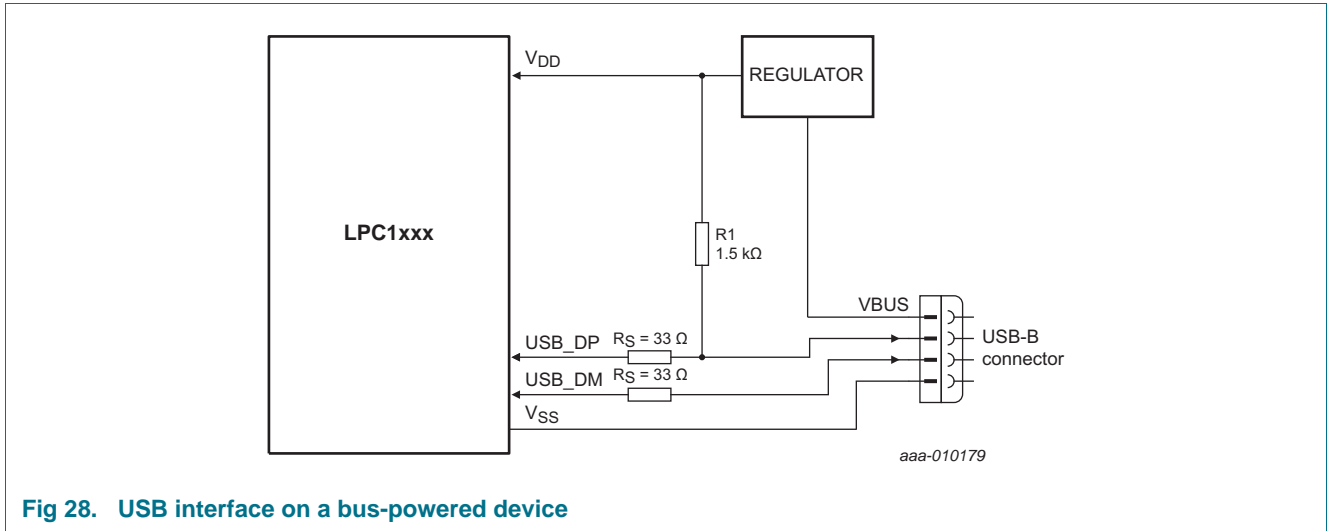

Fig 28. USB interface on a bus-powered device

Remark: When a bus-powered circuit as shown in [Figure 28](#) is used, configure the `PIO0_3/USB_VBUS` pin for GPIO (`PIO0_3`) in the `IOCON` block to ensure that the `USB_CONNECT` signal can still be controlled by software. For details on the soft-connect feature, see the *LPC11U2x user manual* ([Ref. 1](#)).

Remark: When a self-powered circuit is used without connecting VBUS, configure the `PIO0_3/USB_VBUS` pin for GPIO (`PIO0_3`) and provide software that can detect the host presence through some other mechanism before enabling `USB_CONNECT` and the soft-connect feature. Enabling the soft-connect without host presence will lead to USB compliance failure.

11.2 XTAL input

The input voltage to the on-chip oscillators is limited to 1.8 V. If the oscillator is driven by a clock in slave mode, it is recommended that the input be coupled through a capacitor with $C_i = 100 \text{ pF}$. To limit the input voltage to the specified range, choose an additional capacitor to ground C_g which attenuates the input voltage by a factor $C_i / (C_i + C_g)$. In slave mode, a minimum of 200 mV (RMS) is needed.

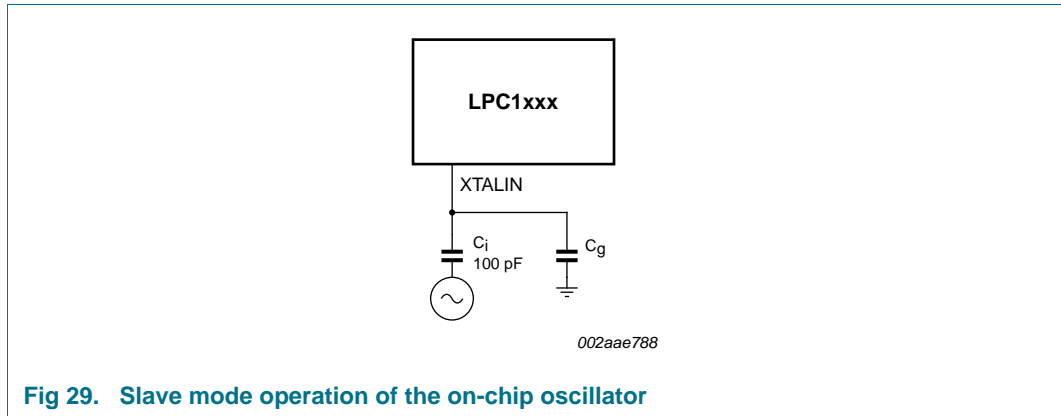

Fig 29. Slave mode operation of the on-chip oscillator

In slave mode, couple the input clock signal with a capacitor of 100 pF (Figure 29), with an amplitude between 200 mV (RMS) and 1000 mV (RMS). This signal corresponds to a square wave signal with a signal swing of between 280 mV and 1.4 V. The XTALOUT pin in this configuration can be left unconnected.

External components and models used in oscillation mode are shown in Figure 30 and in Table 18 and Table 19. Since the feedback resistance is integrated on chip, only a crystal and the capacitances C_{X1} and C_{X2} need to be connected externally in case of fundamental mode oscillation (L , C_L and R_S represent the fundamental frequency). Capacitance C_P in Figure 30 represents the parallel package capacitance and must not be larger than 7 pF. Parameters F_{OSC} , C_L , R_S and C_P are supplied by the crystal manufacturer.

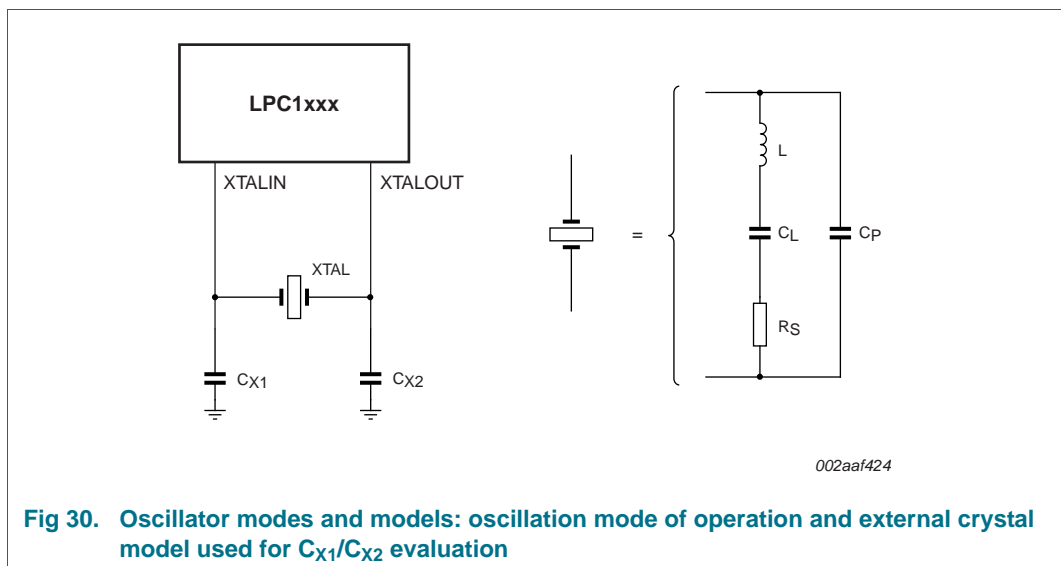

Fig 30. Oscillator modes and models: oscillation mode of operation and external crystal model used for C_{X1}/C_{X2} evaluation

Table 18. Recommended values for C_{X1}/C_{X2} in oscillation mode (crystal and external components parameters) low frequency mode

Fundamental oscillation frequency F_{osc}	Crystal load capacitance C_L	Maximum crystal series resistance R_S	External load capacitors C_{X1}, C_{X2}
1 MHz to 5 MHz	10 pF	< 300 Ω	18 pF, 18 pF
	20 pF	< 300 Ω	39 pF, 39 pF
	30 pF	< 300 Ω	57 pF, 57 pF
5 MHz to 10 MHz	10 pF	< 300 Ω	18 pF, 18 pF
	20 pF	< 200 Ω	39 pF, 39 pF
	30 pF	< 100 Ω	57 pF, 57 pF
10 MHz to 15 MHz	10 pF	< 160 Ω	18 pF, 18 pF
	20 pF	< 60 Ω	39 pF, 39 pF
15 MHz to 20 MHz	10 pF	< 80 Ω	18 pF, 18 pF

Table 19. Recommended values for C_{X1}/C_{X2} in oscillation mode (crystal and external components parameters) high frequency mode

Fundamental oscillation frequency F_{osc}	Crystal load capacitance C_L	Maximum crystal series resistance R_S	External load capacitors C_{X1}, C_{X2}
15 MHz to 20 MHz	10 pF	< 180 Ω	18 pF, 18 pF
	20 pF	< 100 Ω	39 pF, 39 pF
20 MHz to 25 MHz	10 pF	< 160 Ω	18 pF, 18 pF
	20 pF	< 80 Ω	39 pF, 39 pF

11.3 XTAL Printed-Circuit Board (PCB) layout guidelines

Follow these guidelines for PCB layout:

- Connect the crystal on the PCB as close as possible to the oscillator input and output pins of the chip.
- Take care that the load capacitors C_{X1} , C_{X2} , and C_{X3} in case of third overtone crystal use have a common ground plane.
- Connect the external components to the ground plain.
- To keep parasitics and the noise coupled in via the PCB as small as possible, keep loops as small as possible.
- Choose smaller values of C_{X1} and C_{X2} if parasitics of the PCB layout increase.

11.4 Standard I/O pad configuration

Figure 31 shows the possible pin modes for standard I/O pins with analog input function:

- Digital output driver
- Digital input: Pull-up enabled/disabled
- Digital input: Pull-down enabled/disabled
- Digital input: Repeater mode enabled/disabled
- Analog input

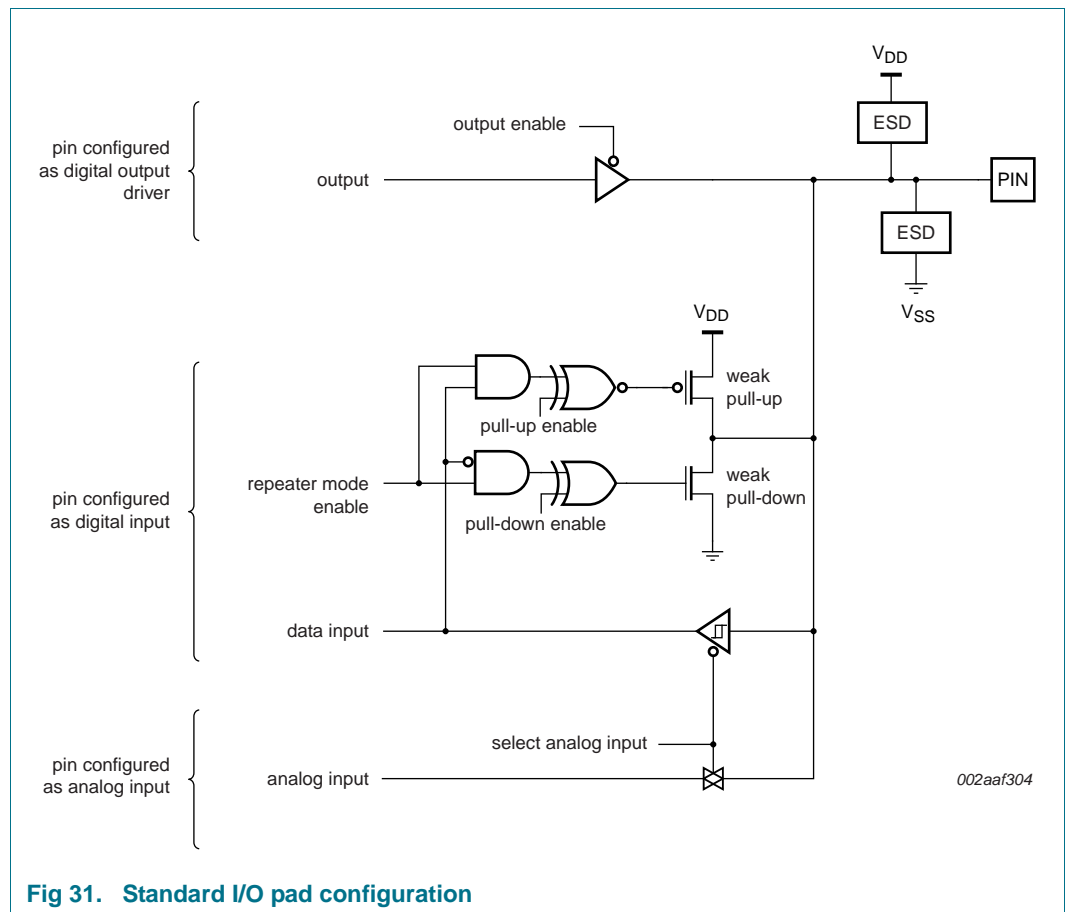

Fig 31. Standard I/O pad configuration

11.5 Reset pad configuration



Fig 32. Reset pad configuration

11.6 ADC effective input impedance

A simplified diagram of the ADC input channels can be used to determine the effective input impedance seen from an external voltage source. See [Figure 33](#).

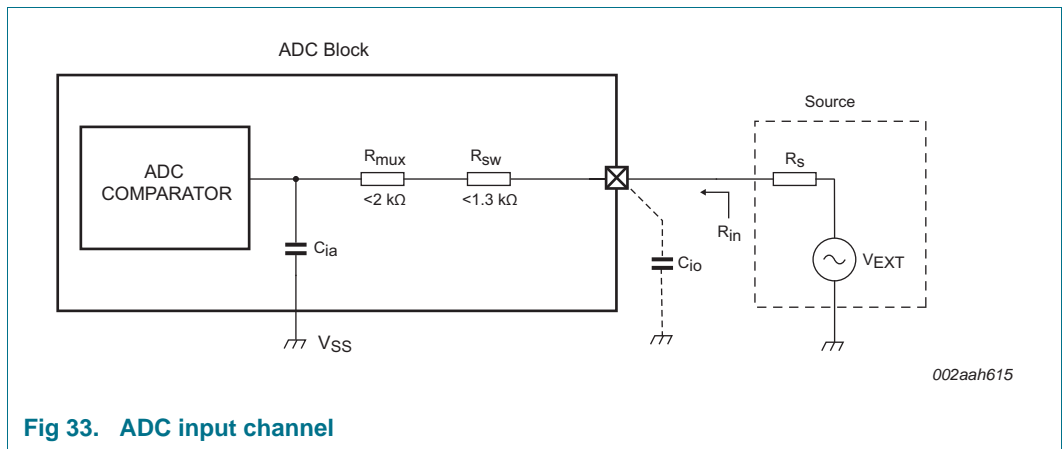

Fig 33. ADC input channel

The effective input impedance, R_{in} , seen by the external voltage source, V_{EXT} , is the parallel impedance of $((1/f_s \times C_{ia}) + R_{mux} + R_{sw})$ and $(1/f_s \times C_{io})$, and can be calculated using [Equation 1](#) with

- f_s = sampling frequency
- C_{ia} = ADC analog input capacitance
- R_{mux} = analog mux resistance
- R_{sw} = switch resistance
- C_{io} = pin capacitance

$$R_{in} = \left(\frac{1}{f_s \times C_{ia}} + R_{mux} + R_{sw} \right) \parallel \left(\frac{1}{f_s \times C_{io}} \right) \tag{1}$$

Under nominal operating condition $V_{DD} = 3.3\text{ V}$ and with the maximum sampling frequency $f_s = 400\text{ kHz}$, the parameters assume the following values:

$$C_{ia} = 1\text{ pF (max)}$$

$$R_{mux} = 2\text{ k}\Omega\text{ (max)}$$

$$R_{sw} = 1.3\text{ k}\Omega\text{ (max)}$$

$$C_{io} = 7.1\text{ pF (max)}$$

The effective input impedance with these parameters is $R_{in} = 308\text{ k}\Omega$.

11.7 ADC usage notes

The following guidelines show how to increase the performance of the ADC in a noisy environment beyond the ADC specifications listed in [Table 6](#):

- The ADC input trace must be short and as close as possible to the LPC11U2x chip.
- Shield The ADC input traces from fast switching digital signals and noisy power supply lines.
- The ADC and the digital core share the same power supply. Therefore, filter the power supply line adequately.
- To improve the ADC performance in a noisy environment, put the device in Sleep mode during the ADC conversion.

12. Package outline

HVQFN33: plastic thermal enhanced very thin quad flat package; no leads; 33 terminals; body 7 x 7 x 0.85 mm

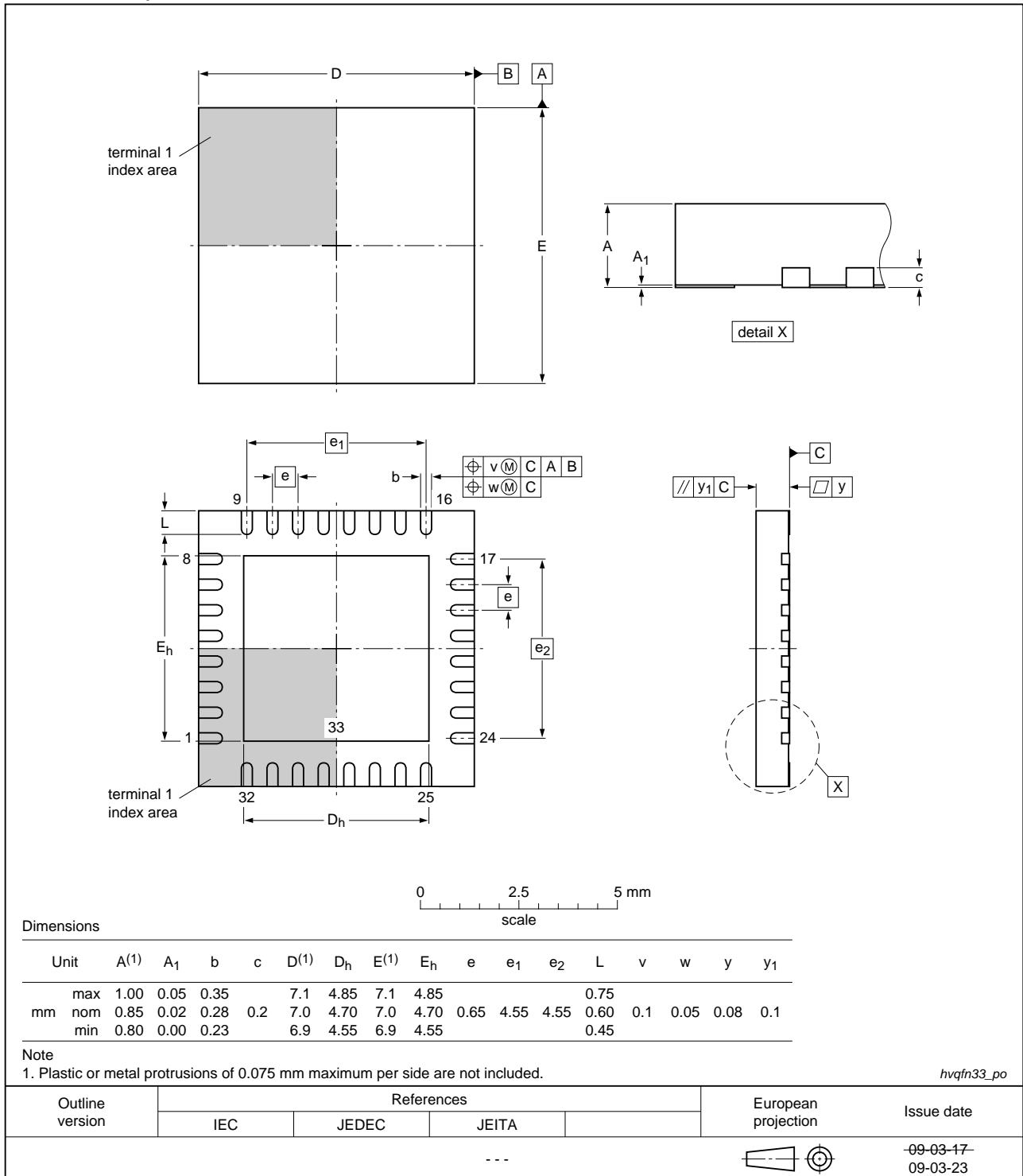

Fig 34. Package outline HVQFN33 (7 x 7 x 0.85 mm)

**HVQFN33: plastic thermal enhanced very thin quad flat package; no leads;
32 terminals; body 5 x 5 x 0.85 mm**



Fig 35. Package outline HVQFN33 (5 x 5 x 0.85 mm)

LQFP48: plastic low profile quad flat package; 48 leads; body 7 x 7 x 1.4 mm

SOT313-2



Fig 36. Package outline LQFP48 (SOT313-2)

LQFP64: plastic low profile quad flat package; 64 leads; body 10 x 10 x 1.4 mm

SOT314-2

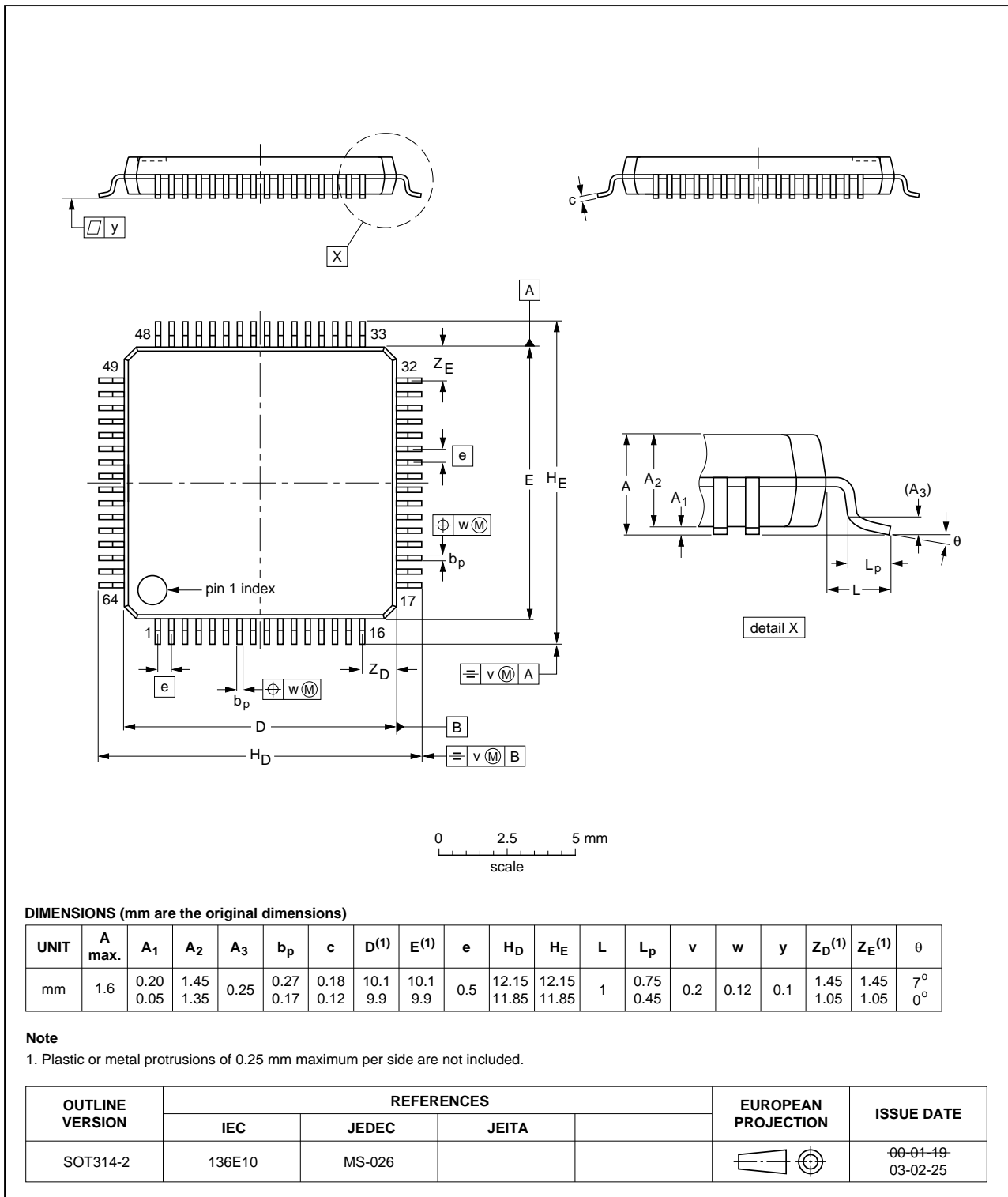

Fig 37. Package outline LQFP64 (SOT314-2)

TFBGA48: plastic thin fine-pitch ball grid array package; 48 balls; body 4.5 x 4.5 x 0.7 mm

SOT1155-2

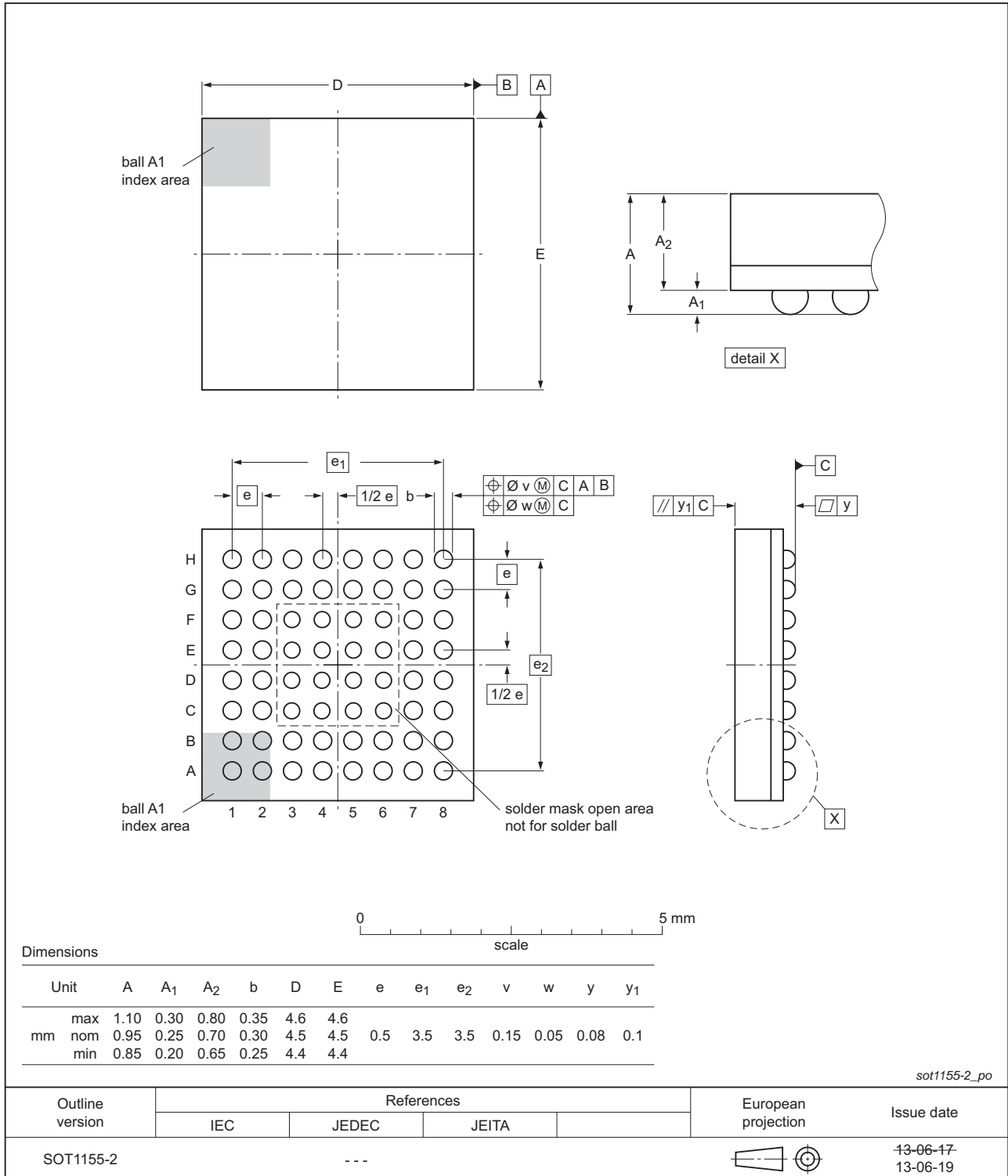
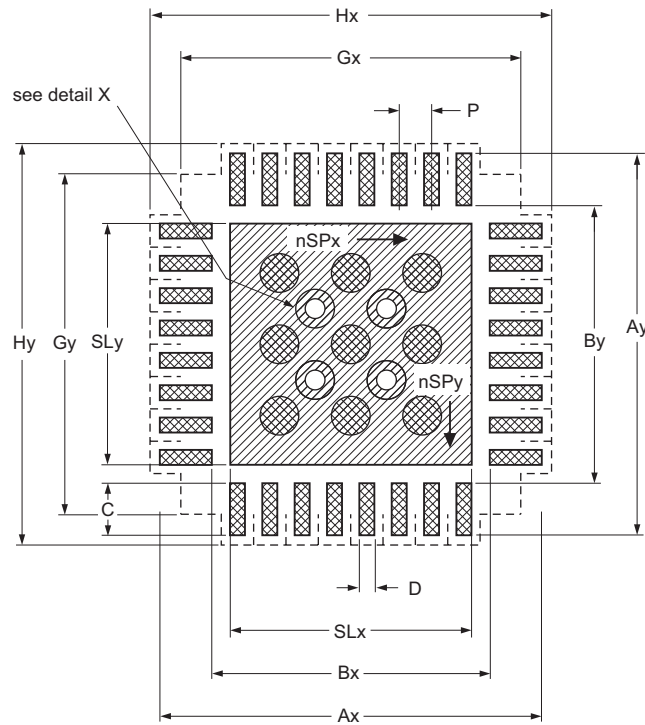

Fig 38. Package outline TFBGA48 (SOT1155-2)

13. Soldering

Footprint information for reflow soldering of HVQFN33 package



- solder land
- solder paste
- occupied area

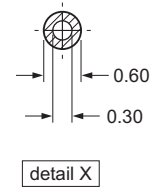

Dimensions in mm

P	Ax	Ay	Bx	By	C	D	Gx	Gy	Hx	Hy	SLx	SLy	nSPx	nSPy
0.5	5.95	5.95	4.25	4.25	0.85	0.27	5.25	5.25	6.2	6.2	3.75	3.75	3	3

Issue date ~~11-11-15~~
11-11-20

002aag766

Fig 39. Reflow soldering for the HVQFN33 (5x5) package

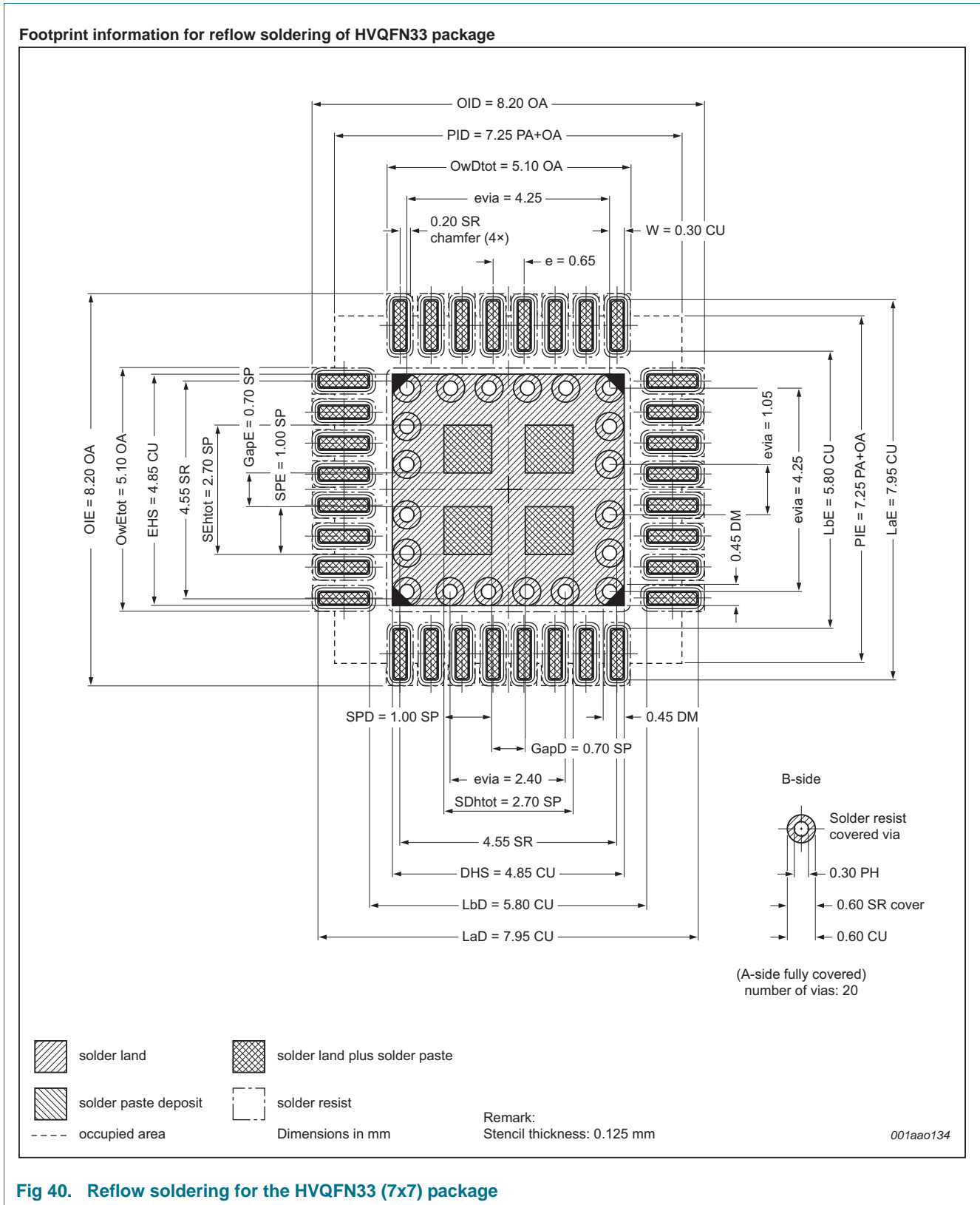

Fig 40. Reflow soldering for the HVQFN33 (7x7) package

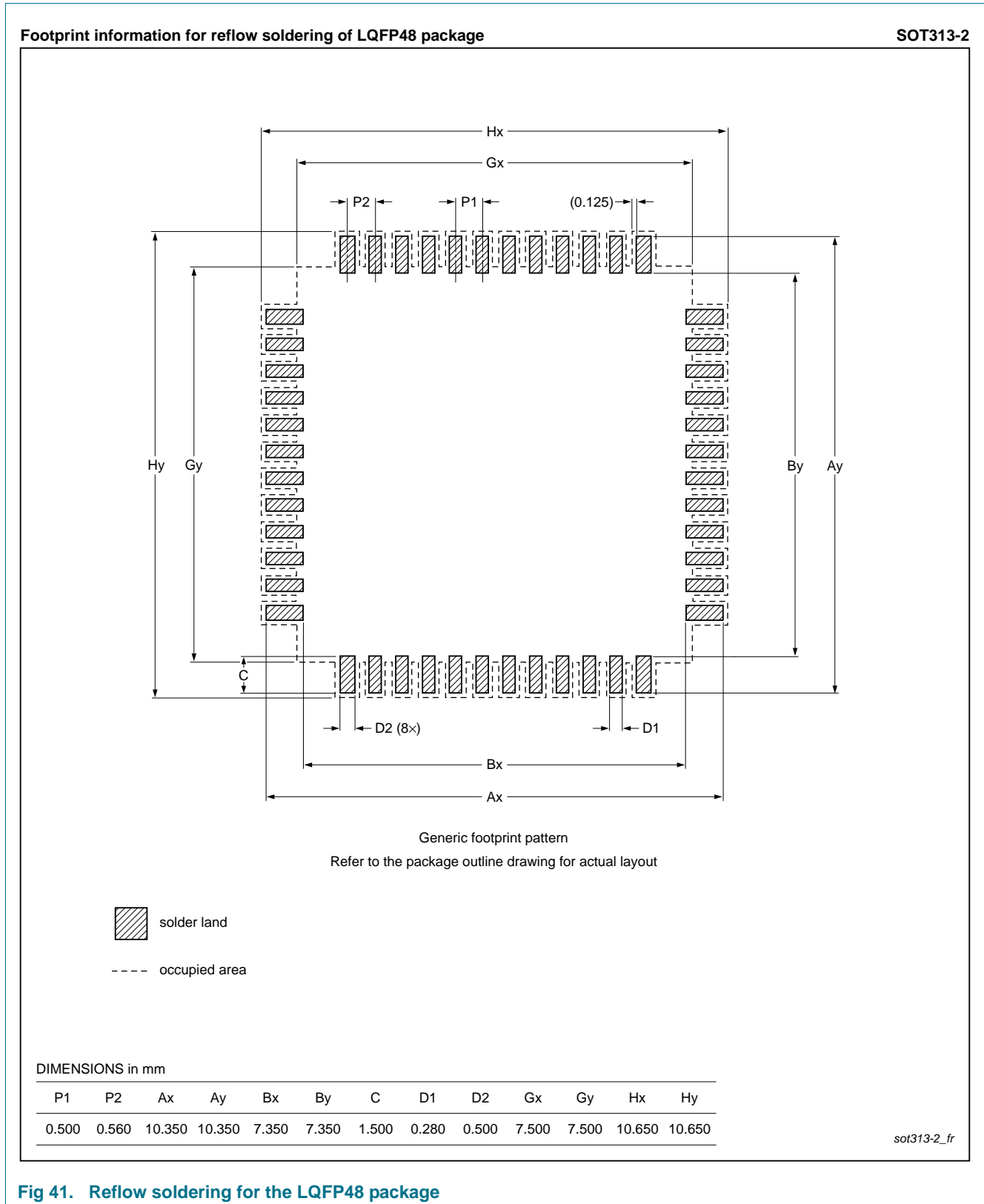

Fig 41. Reflow soldering for the LQFP48 package

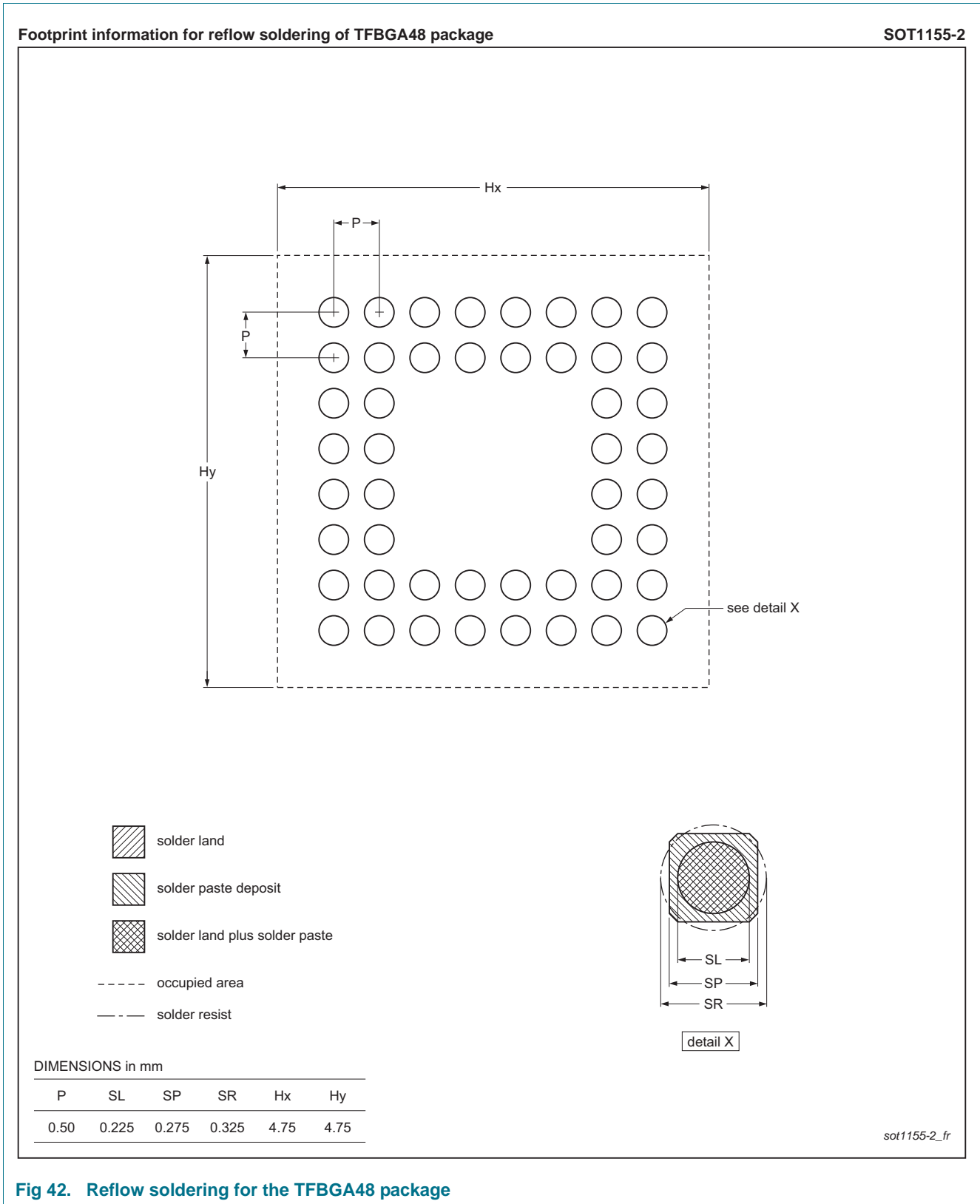

Fig 42. Reflow soldering for the TFBGA48 package

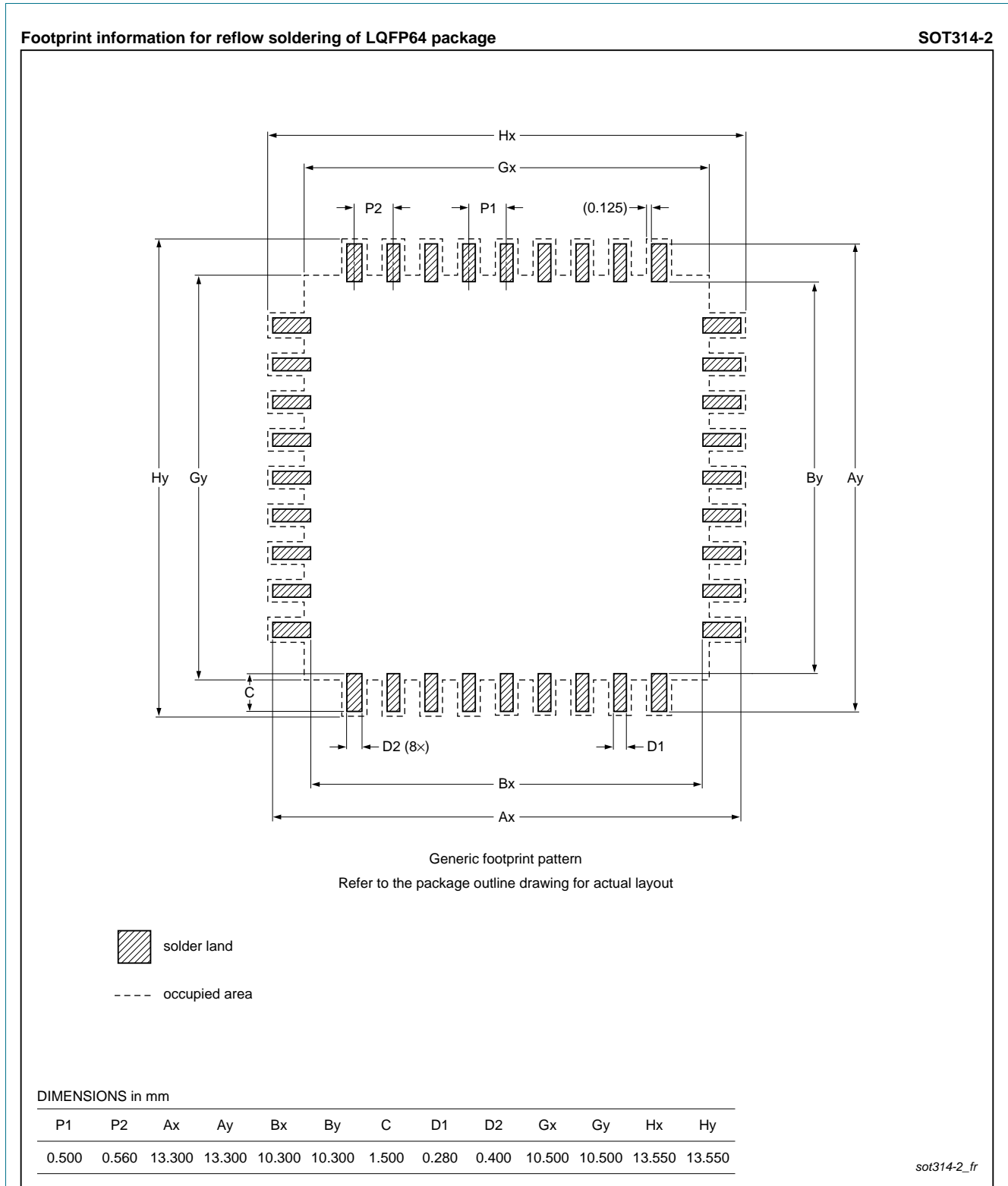

Fig 43. Reflow soldering for the LQFP64 package

14. Abbreviations

Table 20. Abbreviations

Acronym	Description
A/D	Analog-to-Digital
ADC	Analog-to-Digital Converter
AHB	Advanced High-performance Bus
APB	Advanced Peripheral Bus
BOD	BrownOut Detection
GPIO	General Purpose Input/Output
JTAG	Joint Test Action Group
PLL	Phase-Locked Loop
RC	Resistor-Capacitor
SPI	Serial Peripheral Interface
SSI	Serial Synchronous Interface
SSP	Synchronous Serial Port
TAP	Test Access Port
USART	Universal Synchronous Asynchronous Receiver/Transmitter

15. References

- [1] LPC11U2x User manual UM10462:
http://www.nxp.com/documents/user_manual/UM10462.pdf
- [2] LPC11U2x Errata sheet:
http://www.nxp.com/documents/errata_sheet/ES_LPC11U2X.pdf

16. Revision history

Table 21. Revision history

Document ID	Release date	Data sheet status	Change notice	Supersedes
LPC11U2x v.2.3	20140327	Product data sheet	-	LPC11U2X v.2.2
	Part LPC11U22FBD48/301 added.			
LPC11U2X v.2.2	20140311	Product data sheet	-	LPC11U2X v.2.1
Modifications:	<ul style="list-style-type: none"> Updated Section 11.1 “Suggested USB interface solutions” for clarity. Open-drain I²C-bus and $\overline{\text{RESET}}$ pin descriptions updated for clarity. See Table 3. 			
LPC11U2X v.2.1	20130917	Product data sheet	-	LPC11U2X v.2
Modifications:	<ul style="list-style-type: none"> Number of CAP and MAT functions for timers updated in Figure 1. Table 3: Added “5 V tolerant pad” to $\overline{\text{RESET}}/\text{PIO0}_0$ table note. Table 7: Removed BOD interrupt level 0. Added Section 11.6 “ADC effective input impedance”. Programmable glitch filter is enabled by default. See Section 7.7.1. Table 5 “Static characteristics” added Pin capacitance section. Updated Section 11.1 “Suggested USB interface solutions”. Table 4 “Limiting values”: <ul style="list-style-type: none"> Updated V_{DD} min and max. Updated V_{I} conditions. Table 10 “EEPROM characteristics”: <ul style="list-style-type: none"> Removed f_{clk} and t_{er}; the user does not have control over these parameters. Changed the t_{prog} from 1.1 ms to 2.9 ms; the EEPROM IAP always does an erase and program, thus the total program time is $t_{\text{er}} + t_{\text{prog}}$. Changed title of Figure 29 from “USB interface on a self-powered device” to “USB interface with soft-connect”. Section 10.7 “USB interface” added. Parameter t_{EOPR1} and t_{EOPR2} renamed to t_{EOPR}. 			
LPC11U2X v.2	20120113	Product data sheet	-	LPC11U2X v.1
Modifications:	<ul style="list-style-type: none"> Use of USB with power profiles specified (Section 7.17.5.1). Power consumption data added in Section 9.2. SSP dynamic characteristics added (Table 16). IRC dynamic characteristics added (Table 12). Data sheet status changed to Product data sheet. 			
LPC11U2X v.1	20111129	Preliminary data sheet	-	-

17. Legal information

17.1 Data sheet status

Document status ^{[1][2]}	Product status ^[3]	Definition
Objective [short] data sheet	Development	This document contains data from the objective specification for product development.
Preliminary [short] data sheet	Qualification	This document contains data from the preliminary specification.
Product [short] data sheet	Production	This document contains the product specification.

[1] Please consult the most recently issued document before initiating or completing a design.

[2] The term 'short data sheet' is explained in section "Definitions".

[3] The product status of device(s) described in this document may have changed since this document was published and may differ in case of multiple devices. The latest product status information is available on the Internet at URL <http://www.nxp.com>.

17.2 Definitions

Draft — The document is a draft version only. The content is still under internal review and subject to formal approval, which may result in modifications or additions. NXP Semiconductors does not give any representations or warranties as to the accuracy or completeness of information included herein and shall have no liability for the consequences of use of such information.

Short data sheet — A short data sheet is an extract from a full data sheet with the same product type number(s) and title. A short data sheet is intended for quick reference only and should not be relied upon to contain detailed and full information. For detailed and full information see the relevant full data sheet, which is available on request via the local NXP Semiconductors sales office. In case of any inconsistency or conflict with the short data sheet, the full data sheet shall prevail.

Product specification — The information and data provided in a Product data sheet shall define the specification of the product as agreed between NXP Semiconductors and its customer, unless NXP Semiconductors and customer have explicitly agreed otherwise in writing. In no event however, shall an agreement be valid in which the NXP Semiconductors product is deemed to offer functions and qualities beyond those described in the Product data sheet.

17.3 Disclaimers

Limited warranty and liability — Information in this document is believed to be accurate and reliable. However, NXP Semiconductors does not give any representations or warranties, expressed or implied, as to the accuracy or completeness of such information and shall have no liability for the consequences of use of such information. NXP Semiconductors takes no responsibility for the content in this document if provided by an information source outside of NXP Semiconductors.

In no event shall NXP Semiconductors be liable for any indirect, incidental, punitive, special or consequential damages (including - without limitation - lost profits, lost savings, business interruption, costs related to the removal or replacement of any products or rework charges) whether or not such damages are based on tort (including negligence), warranty, breach of contract or any other legal theory.

Notwithstanding any damages that customer might incur for any reason whatsoever, NXP Semiconductors' aggregate and cumulative liability towards customer for the products described herein shall be limited in accordance with the *Terms and conditions of commercial sale* of NXP Semiconductors.

Right to make changes — NXP Semiconductors reserves the right to make changes to information published in this document, including without limitation specifications and product descriptions, at any time and without notice. This document supersedes and replaces all information supplied prior to the publication hereof.

Suitability for use — NXP Semiconductors products are not designed, authorized or warranted to be suitable for use in life support, life-critical or safety-critical systems or equipment, nor in applications where failure or malfunction of an NXP Semiconductors product can reasonably be expected to result in personal injury, death or severe property or environmental damage. NXP Semiconductors and its suppliers accept no liability for inclusion and/or use of NXP Semiconductors products in such equipment or applications and therefore such inclusion and/or use is at the customer's own risk.

Applications — Applications that are described herein for any of these products are for illustrative purposes only. NXP Semiconductors makes no representation or warranty that such applications will be suitable for the specified use without further testing or modification.

Customers are responsible for the design and operation of their applications and products using NXP Semiconductors products, and NXP Semiconductors accepts no liability for any assistance with applications or customer product design. It is customer's sole responsibility to determine whether the NXP Semiconductors product is suitable and fit for the customer's applications and products planned, as well as for the planned application and use of customer's third party customer(s). Customers should provide appropriate design and operating safeguards to minimize the risks associated with their applications and products.

NXP Semiconductors does not accept any liability related to any default, damage, costs or problem which is based on any weakness or default in the customer's applications or products, or the application or use by customer's third party customer(s). Customer is responsible for doing all necessary testing for the customer's applications and products using NXP Semiconductors products in order to avoid a default of the applications and the products or of the application or use by customer's third party customer(s). NXP does not accept any liability in this respect.

Limiting values — Stress above one or more limiting values (as defined in the Absolute Maximum Ratings System of IEC 60134) will cause permanent damage to the device. Limiting values are stress ratings only and (proper) operation of the device at these or any other conditions above those given in the Recommended operating conditions section (if present) or the Characteristics sections of this document is not warranted. Constant or repeated exposure to limiting values will permanently and irreversibly affect the quality and reliability of the device.

Terms and conditions of commercial sale — NXP Semiconductors products are sold subject to the general terms and conditions of commercial sale, as published at <http://www.nxp.com/profile/terms>, unless otherwise agreed in a valid written individual agreement. In case an individual agreement is concluded only the terms and conditions of the respective agreement shall apply. NXP Semiconductors hereby expressly objects to applying the customer's general terms and conditions with regard to the purchase of NXP Semiconductors products by customer.

No offer to sell or license — Nothing in this document may be interpreted or construed as an offer to sell products that is open for acceptance or the grant, conveyance or implication of any license under any copyrights, patents or other industrial or intellectual property rights.

Export control — This document as well as the item(s) described herein may be subject to export control regulations. Export might require a prior authorization from competent authorities.

Non-automotive qualified products — Unless this data sheet expressly states that this specific NXP Semiconductors product is automotive qualified, the product is not suitable for automotive use. It is neither qualified nor tested in accordance with automotive testing or application requirements. NXP Semiconductors accepts no liability for inclusion and/or use of non-automotive qualified products in automotive equipment or applications.

In the event that customer uses the product for design-in and use in automotive applications to automotive specifications and standards, customer (a) shall use the product without NXP Semiconductors' warranty of the product for such automotive applications, use and specifications, and (b)

whenever customer uses the product for automotive applications beyond NXP Semiconductors' specifications such use shall be solely at customer's own risk, and (c) customer fully indemnifies NXP Semiconductors for any liability, damages or failed product claims resulting from customer design and use of the product for automotive applications beyond NXP Semiconductors' standard warranty and NXP Semiconductors' product specifications.

17.4 Trademarks

Notice: All referenced brands, product names, service names and trademarks are the property of their respective owners.

I²C-bus — logo is a trademark of NXP Semiconductors N.V.

18. Contact information

For more information, please visit: <http://www.nxp.com>

For sales office addresses, please send an email to: salesaddresses@nxp.com

19. Contents

1	General description	1	7.17.5	Power control	24
2	Features and benefits	1	7.17.5.1	Power profiles	25
3	Applications	3	7.17.5.2	Sleep mode	25
4	Ordering information	3	7.17.5.3	Deep-sleep mode	25
4.1	Ordering options	3	7.17.5.4	Power-down mode	25
5	Block diagram	4	7.17.5.5	Deep power-down mode	26
6	Pinning information	5	7.17.6	System control	26
6.1	Pinning	5	7.17.6.1	Reset	26
6.2	Pin description	9	7.17.6.2	Brownout detection	26
7	Functional description	14	7.17.6.3	Code security (Code Read Protection - CRP)	26
7.1	On-chip flash programming memory	14	7.17.6.4	APB interface	27
7.2	EEPROM	14	7.17.6.5	AHBLite	27
7.3	SRAM	15	7.17.6.6	External interrupt inputs	27
7.4	On-chip ROM	15	7.18	Emulation and debugging	28
7.5	Memory map	15	8	Limiting values	29
7.6	Nested Vectored Interrupt Controller (NVIC)	16	9	Static characteristics	30
7.6.1	Features	16	9.1	BOD static characteristics	36
7.6.2	Interrupt sources	17	9.2	Power consumption	36
7.7	IOCON block	17	9.3	Peripheral power consumption	39
7.7.1	Features	17	9.4	Electrical pin characteristics	41
7.8	General-Purpose Input/Output GPIO	17	10	Dynamic characteristics	44
7.8.1	Features	18	10.1	Flash memory	44
7.9	USB interface	18	10.2	External clock	44
7.9.1	Full-speed USB device controller	18	10.3	Internal oscillators	45
7.9.1.1	Features	18	10.4	I/O pins	46
7.10	USART	18	10.5	I ² C-bus	46
7.10.1	Features	19	10.6	SSP interface	48
7.11	SSP serial I/O controller	19	10.7	USB interface	51
7.11.1	Features	19	11	Application information	52
7.12	I ² C-bus serial I/O controller	19	11.1	Suggested USB interface solutions	52
7.12.1	Features	20	11.2	XTAL input	53
7.13	10-bit ADC	20	11.3	XTAL Printed-Circuit Board (PCB) layout guidelines	55
7.13.1	Features	20	11.4	Standard I/O pad configuration	56
7.14	General purpose external event counter/timers	20	11.5	Reset pad configuration	57
7.14.1	Features	20	11.6	ADC effective input impedance	57
7.15	System tick timer	21	11.7	ADC usage notes	58
7.16	Windowed WatchDog Timer (WWDT)	21	12	Package outline	59
7.16.1	Features	21	13	Soldering	64
7.17	Clocking and power control	22	14	Abbreviations	69
7.17.1	Integrated oscillators	22	15	References	69
7.17.1.1	Internal RC oscillator	23	16	Revision history	70
7.17.1.2	System oscillator	24	17	Legal information	71
7.17.1.3	Watchdog oscillator	24	17.1	Data sheet status	71
7.17.2	System PLL and USB PLL	24	17.2	Definitions	71
7.17.3	Clock output	24	17.3	Disclaimers	71
7.17.4	Wake-up process	24			

continued >>

17.4	Trademarks.....	72
18	Contact information.....	72
19	Contents.....	73

Please be aware that important notices concerning this document and the product(s) described herein, have been included in section 'Legal information'.

© NXP B.V. 2014.

All rights reserved.

For more information, please visit: <http://www.nxp.com>

For sales office addresses, please send an email to: salesaddresses@nxp.com

Date of release: 27 March 2014

Document identifier: LPC11U2X

Компания «Life Electronics» занимается поставками электронных компонентов импортного и отечественного производства от производителей и со складов крупных дистрибьюторов Европы, Америки и Азии.

С конца 2013 года компания активно расширяет линейку поставок компонентов по направлению коаксиальный кабель, кварцевые генераторы и конденсаторы (керамические, пленочные, электролитические), за счёт заключения дистрибьюторских договоров

Мы предлагаем:

- Конкуренспособные цены и скидки постоянным клиентам.
- Специальные условия для постоянных клиентов.
- Подбор аналогов.
- Поставку компонентов в любых объемах, удовлетворяющих вашим потребностям.
- Приемлемые сроки поставки, возможна ускоренная поставка.
- Доставку товара в любую точку России и стран СНГ.
- Комплексную поставку.
- Работу по проектам и поставку образцов.
- Формирование склада под заказчика.
- Сертификаты соответствия на поставляемую продукцию (по желанию клиента).
- Тестирование поставляемой продукции.
- Поставку компонентов, требующих военную и космическую приемку.
- Входной контроль качества.
- Наличие сертификата ISO.

В составе нашей компании организован Конструкторский отдел, призванный помогать разработчикам, и инженерам.

Конструкторский отдел помогает осуществить:

- Регистрацию проекта у производителя компонентов.
- Техническую поддержку проекта.
- Защиту от снятия компонента с производства.
- Оценку стоимости проекта по компонентам.
- Изготовление тестовой платы монтаж и пусконаладочные работы.



Тел: +7 (812) 336 43 04 (многоканальный)
Email: org@lifeelectronics.ru