

RJ45 Weathertight Connectors



RJ45 Weathertight Connectors

Features & Benefits

- Sealed to IP67 & IP68 NEMA 250 (6P) (when mated)
- Molded cable assemblies available
- CAT 5E or CAT 6 available in shielded or unshielded versions as standard
- Feed through or IDC panel terminals for easy field installation
- Field installable design is easy to assemble
- Dust cap available

Applications

- Any sealed data transmission
- Military or industrial GPS location devices
- Instrumentation
- Medical data carts
- Data acquisition units
- General industrial electronic applications

RJ45 Weathertight Connectors

Specifications

Materials:

Field Installable Plug Assembly:

Sealing Nut, Coupling Ring: Thermoplastic

Plug Housing, Insert: Thermoplastic

Sealing Ring: Elastomer

O-Ring: Elastomer

RJ45 Plug:

Insulator: Thermoplastic

Contacts: Copper Alloy, Gold Plated

Shield (Shielded Option Only): Copper Alloy, Tin Plated

Panel Housing Jack Assembly:

Panel Housing, Hex Nut: Thermoplastic

Gasket: Elastomer

RJ45 Jack:

Housing: Thermoplastic

Contacts: Copper Alloy, Gold Plated

Printed Circuit Board (PCB): FR-4

IDC Contacts: Copper Alloy, Tin Plated

Electrical:

Contact Resistance: 20 milliohms Max

Insulation Resistance: 500M ohms Min

Withstanding Voltage: 1000V DC

Mechanical:

Vibration: Mil-Std 202G Method 201A

Environmental:

Operating Temperature: -10 °C to +60 °C

Moisture Resistance: Mil-Std 202G Method 106G

Insulation Resistance: Mil-Std 202G Method 302G

Thermal Shock: Mil-Std 202G Method 107G

Product Rating:

IP67 & IP68, NEMA 250 (6P) (when mated)

RJ45 Cable Plug (Category 6): TIA/EIA 568 C.2

RJ45 Panel Jack (Category 5e): TIA/EIA 568 B.2

RJ45 Panel Jack (Category 6): TIA/EIA 568 B.2

Other:

Recommended Panel Thickness:

Quick Connect Coupling: 1/32" to 3/16"
(0.8mm to 4.8mm)

Threaded Coupling: 1/32" to 5/32"
(0.8mm to 3.9mm)

Recommended Cable Type:

Conductor Type: Solid or Stranded Conductors

Outer Cable O.D. Range: Ø0.190 to Ø0.250
(4.83mm to 6.35mm)

Conductor insulator O.D. Range: Ø0.037 to Ø0.042
(0.94mm to 1.06mm)

Recommended Crimp/Termination Tools:

Sentinel Hand Ratchet Tool, Part Number "900005"

Sentinel Die Set, Part Number "900216"

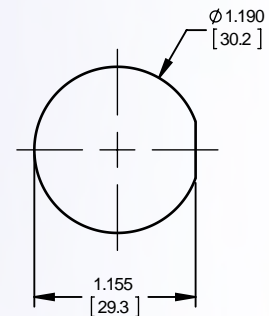

RECOMMENDED PANEL CUT-OUT
(THREADED OR QUICK CONNECT COUPLING)
± 0.003 [±0.07]

Molded Cable Assemblies

Custom overmolded cable assemblies available
Please contact us with your requirements



RJ45 Weathertight Connectors

RJ45 Weathertight Connectors

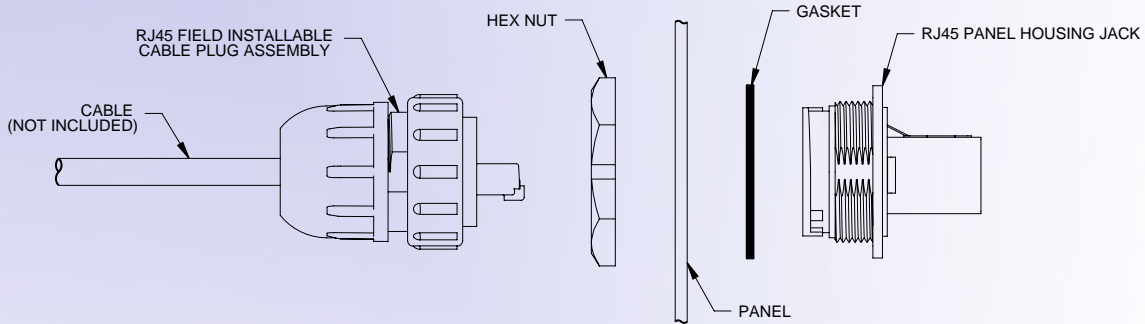

**RJ45 FIELD INSTALLABLE CABLE PLUG ASSEMBLY
(THREADED COUPLING)**

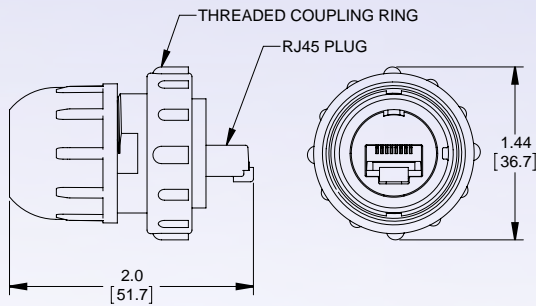

**RJ45 FIELD INSTALLABLE CABLE PLUG ASSEMBLY
(QUICK CONNECT COUPLING)**

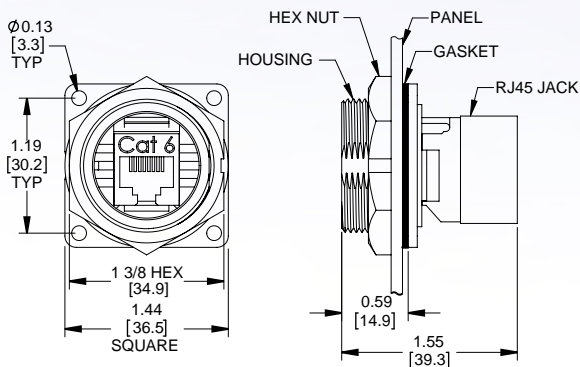
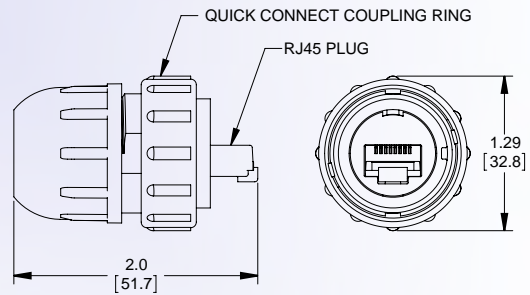

**RJ45 PANEL HOUSING IDC JACK
(SHOWN WITH SHIELDED CAT 6 JACK)
(SHOWN WITH THREADED HOUSING)**

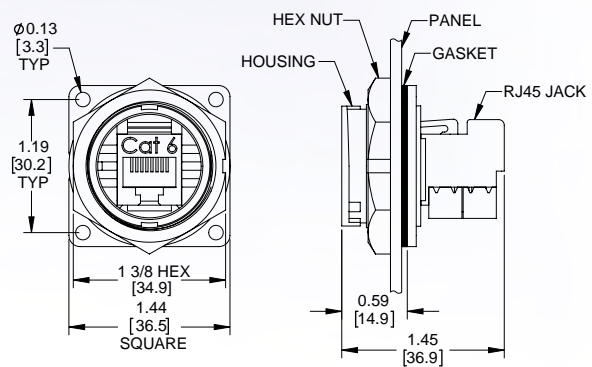

**RJ45 PANEL HOUSING IDC RIGHT ANGLE JACK
(SHOWN WITH NON-SHIELDED CAT 6 JACK)
(SHOWN WITH QUICK CONNECT HOUSING)**

RJ45 Weathertight Connectors

Part Number Charts

DCC	RJ6	X	X	310
RJ45 FIELD INSTALLABLE CABLE PLUG ASSEMBLY	PLUG TYPE	PLUG SHIELDING	COUPLING TYPE	SERIES
DCC	RJ6 = RJ45 CAT 6	BLANK = UNSHIELDED S = SHIELDED	B = QUICK CONNECT T = THREADED	310

DCP	XXX	X	X	XX
RJ45 FIELD INSTALLABLE PANEL HOUSING ASSEMBLY	JACK TYPE	JACK SHIELDING	COUPLING TYPE	SERIES
DCP	RJ5 = RJ45 CAT 5e RJ6 = RJ45 CAT 6	BLANK = UNSHIELDED S = SHIELDED	B = QUICK CONNECT T = THREADED	F = FEED-THRU (TO SAME CONNECTOR) SD = IDC, STRAIGHT RD = IDC, RIGHT ANGLE

Assembly Instructions

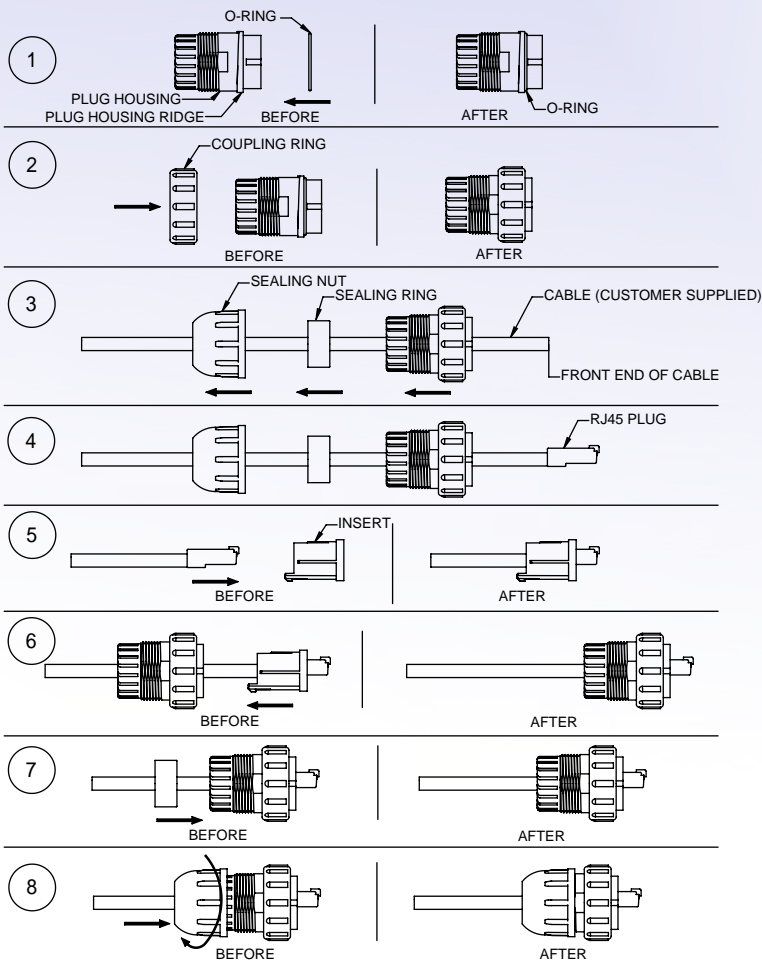

- Slide the O-ring onto the front end of the plug housing until it seats up against the ridge on the plug housing
- Slide the coupling ring over the plug housing
NOTE: Make sure the front of the coupling ring can slide past the ridge on the plug housing. If not, it is inserted the wrong way
- Slide the sealing nut, sealing ring and plug housing/ coupling ring over the front end of the cable in the following order:
1st sealing nut
2nd sealing ring
3rd plug housing / coupling ring
- Terminate the RJ45 plug to the cable
NOTE: See supplemental termination guide for cable termination instructions
- Slide the RJ45 plug into the back end of the insert until it snaps into place
- Slide the insert/RJ45 plug into the front end of the plug housing until it snaps into place
- Push the sealing ring into the rear of the plug housing
NOTE: No part of the sealing ring should extend past the rear of the plug housing
- Screw the sealing nut onto the plug housing

Компания «Life Electronics» занимается поставками электронных компонентов импортного и отечественного производства от производителей и со складов крупных дистрибьюторов Европы, Америки и Азии.

С конца 2013 года компания активно расширяет линейку поставок компонентов по направлению коаксиальный кабель, кварцевые генераторы и конденсаторы (керамические, пленочные, электролитические), за счёт заключения дистрибьюторских договоров

Мы предлагаем:

- Конкурентоспособные цены и скидки постоянным клиентам.
- Специальные условия для постоянных клиентов.
- Подбор аналогов.
- Поставку компонентов в любых объемах, удовлетворяющих вашим потребностям.
- Приемлемые сроки поставки, возможна ускоренная поставка.
- Доставку товара в любую точку России и стран СНГ.
- Комплексную поставку.
- Работу по проектам и поставку образцов.
- Формирование склада под заказчика.
- Сертификаты соответствия на поставляемую продукцию (по желанию клиента).
- Тестирование поставляемой продукции.
- Поставку компонентов, требующих военную и космическую приемку.
- Входной контроль качества.
- Наличие сертификата ISO.

В составе нашей компании организован Конструкторский отдел, призванный помогать разработчикам, и инженерам.

Конструкторский отдел помогает осуществить:

- Регистрацию проекта у производителя компонентов.
- Техническую поддержку проекта.
- Защиту от снятия компонента с производства.
- Оценку стоимости проекта по компонентам.
- Изготовление тестовой платы монтаж и пусконаладочные работы.



Тел: +7 (812) 336 43 04 (многоканальный)
Email: org@lifeelectronics.ru