

Thermocouple measuring transducer - MINI MCR-TC-UI-NC - 2902851

Please be informed that the data shown in this PDF Document is generated from our Online Catalog. Please find the complete data in the user's documentation. Our General Terms of Use for Downloads are valid (<http://download.phoenixcontact.com>)



Configurable temperature transducer for the connection of thermocouples. Can be configured via DIP switches or, with extended functionality, using the software. Screw connection, standard configuration.

Product description

The configurable temperature transducer with 3-way isolation is suitable for the connection of thermocouples.

The measured values are converted into a linear current or voltage signal.

The device can either be configured via DIP switches or, with extended functionality, via the S port using the software (FDT/DTM). The measuring transducer supports fault monitoring.



Key commercial data

Packing unit	1 PCE
GTIN	 4 046356 689229
Custom tariff number	85437090
Country of origin	GERMANY

Technical data

Note:

Utilization restriction	EMC: class A product, see manufacturer's declaration in the download area
-------------------------	---

Dimensions

Width	6.2 mm
Height	93.1 mm
Depth	102.5 mm

Ambient conditions

Thermocouple measuring transducer - MINI MCR-TC-UI-NC - 2902851

Technical data

Ambient conditions

Ambient temperature (operation)	-20 °C ... 65 °C
Ambient temperature (storage/transport)	-40 °C ... 85 °C
Degree of protection	IP20

Input data

Configurable/programmable	Yes
Sensor types that can be used (TC)	B, E, J, K, N, R, S, T, L, U, A-1, A-2, A-3, M, L
Temperature measuring range	-250 °C ... 2500 °C (Range depending on the sensor type)

Output data

Configurable/programmable	Yes
Voltage output signal	0 V ... 10 V
	10 V ... 0 V
	0 V ... 5 V
	1 V ... 5 V
Current output signal	0 mA ... 20 mA
	4 mA ... 20 mA
	20 mA ... 0 mA
	20 mA ... 4 mA
Max. output voltage	approx. 12.3 V
Max. output current	24.6 mA
Load/output load voltage output	≥ 10 kΩ
Load/output load current output	< 500 Ω (at 20 mA)

Power supply

Supply voltage range	9.6 V DC ... 30 V DC (The T connector (ME 6,2 TBUS-2 1,5/5-ST-3,81 GN, Order No. 2869728) can be used to bridge the supply voltage. It can be snapped onto a 35 mm DIN rail according to EN 60715))
Typical current consumption	< 27 mA (at 24 V DC)
Power consumption	≤ 700 mW (at I _{OUT} = 20 mA, 9.6 V DC, load 500 Ω)

Connection data

Connection method	Screw connection
Conductor cross section solid min.	0.2 mm ²
Conductor cross section solid max.	2.5 mm ²
Conductor cross section stranded min.	0.2 mm ²
Conductor cross section stranded max.	2.5 mm ²
Conductor cross section AWG/kcmil min.	26
Conductor cross section AWG/kcmil max	12
Stripping length	12 mm

Thermocouple measuring transducer - MINI MCR-TC-UI-NC - 2902851

Technical data

Connection data

Screw thread	M3
--------------	----

General

Maximum temperature coefficient	≤ 0.01 %/K
Cold point error, max.	< 3 K
Typical cold point errors	< 2 K
Status display	LED red
Protective circuit	Transient protection
Electrical isolation	Basic insulation according to EN 61010
Surge voltage category	II
Pollution degree	2
Rated insulation voltage	50 V AC/DC
Test voltage, input/output/supply	1.5 kV (50 Hz, 1 min.)
Electromagnetic compatibility	Conformance with EMC Directive 2004/108/EC
Noise emission	EN 61000-6-4
Noise immunity	EN 61000-6-2 When being exposed to interference, there may be minimal deviations.
Color	green
Housing material	PBT
Mounting position	Any
Conformance	CE-compliant
ATEX	# II 3 G Ex nA IIC T4 Gc X
UL, USA / Canada	508 listed
	Class I, Div. 2, Groups A, B, C, D T5 applied for
GL	GL applied for

Classifications

eCl@ss

eCl@ss 4.0	27200206
eCl@ss 4.1	27200206
eCl@ss 5.0	27200206
eCl@ss 5.1	27200206
eCl@ss 6.0	27200206
eCl@ss 7.0	27200206
eCl@ss 8.0	27200206

Thermocouple measuring transducer - MINI MCR-TC-UI-NC - 2902851

Classifications

ETIM

ETIM 3.0	EC001446
ETIM 4.0	EC001446
ETIM 5.0	EC001446

UNSPSC

UNSPSC 6.01	30211506
UNSPSC 7.0901	39121008
UNSPSC 11	39121008
UNSPSC 12.01	39121008
UNSPSC 13.2	39121008

Approvals

Approvals

Approvals

UL Listed / cUL Listed / cULus Listed

Ex Approvals

Approvals submitted

Approval details

UL Listed

cUL Listed

cULus Listed

Thermocouple measuring transducer - MINI MCR-TC-UI-NC - 2902851

Accessories

Accessories

Cable/conductor

Programming adapter - IFS-USB-PROG-ADAPTER - 2811271



Programming adapter with USB interface, for programming with software.

Electronic housing - ME 6,2 TBUS-2 1,5/5-ST-3,81 GN - 2869728



DIN rail connector for DIN rail mounting. Universal for T-BUS housing. Gold-plated contacts, 5-pos.

Power terminal block - MINI MCR-SL-PTB-FM - 2902958



The MINI MCR-SL-PTB-FM(-SP) power terminal block is used to supply the supply voltage to the T-connector. The FM power terminal block offers the additional function of monitoring in combination with the fault monitoring module. Screw connection.

Power terminal block - MINI MCR-SL-PTB-FM-SP - 2902959



The MINI MCR-SL-PTB-FM(-SP) power terminal block is used to supply the supply voltage to the T-connector. The FM power terminal block offers the additional function of monitoring in combination with the fault monitoring module. Spring-cage connection.

Monitoring module - MINI MCR-SL-FM-RC-NC - 2902961



The fault monitoring module is used to evaluate and report group errors from the fault monitoring system and to monitor the supply voltages. The error is reported via an N/O contact. Screw connection, standard configuration.

Thermocouple measuring transducer - MINI MCR-TC-UI-NC - 2902851

Accessories

Monitoring module - MINI MCR-SL-FM-RC-SP-NC - 2902962



The fault monitoring module is used to evaluate and report group errors from the fault monitoring system and to monitor the supply voltages. The error is reported via an N/O contact. Spring-cage connection, standard configuration.

Power supply unit - MINI-SYS-PS-100-240AC/24DC/1.5 - 2866983



DIN rail power supply unit, primary-switched mode, slim design, output: 24 V DC / 1.5 A

System adapter - MINI MCR-SL-V8-FLK 16-A - 2811268



Eight MINI analog signal converters with screw connection method can be connected to a control system using a system adapter and system cabling with a minimum of wiring and very low error risk.

Multiplexer - MINI MCR-SL-MUX-V8-FLK 16 - 2811815



MINI analog multiplexer, generates one analog output from 8 analog input signals, for MINI analog module with screw connection.

Transparent cover - MINI MCR DKL - 2308111



Fold up transparent cover for MINI MCR modules with additional labeling option using insert strips and flat Zack marker strip 6.2 mm

Thermocouple measuring transducer - MINI MCR-TC-UI-NC - 2902851

Accessories

Marking label - MINI MCR-DKL-LABEL - 2810272



Label for extended marking of MINI MCR modules in connection with the MINI MCR-DKL

Drawings

Block diagram

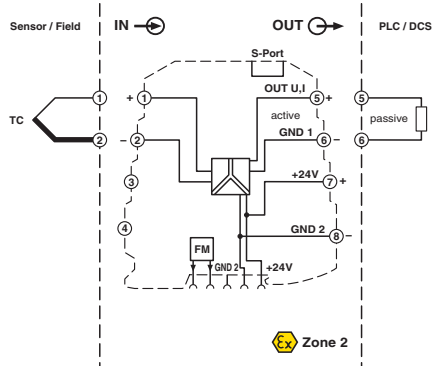

Pictogram

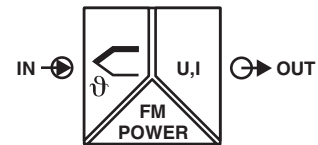

Компания «Life Electronics» занимается поставками электронных компонентов импортного и отечественного производства от производителей и со складов крупных дистрибьюторов Европы, Америки и Азии.

С конца 2013 года компания активно расширяет линейку поставок компонентов по направлению коаксиальный кабель, кварцевые генераторы и конденсаторы (керамические, пленочные, электролитические), за счёт заключения дистрибьюторских договоров

Мы предлагаем:

- Конкурентоспособные цены и скидки постоянным клиентам.
- Специальные условия для постоянных клиентов.
- Подбор аналогов.
- Поставку компонентов в любых объемах, удовлетворяющих вашим потребностям.
- Приемлемые сроки поставки, возможна ускоренная поставка.
- Доставку товара в любую точку России и стран СНГ.
- Комплексную поставку.
- Работу по проектам и поставку образцов.
- Формирование склада под заказчика.
- Сертификаты соответствия на поставляемую продукцию (по желанию клиента).
- Тестирование поставляемой продукции.
- Поставку компонентов, требующих военную и космическую приемку.
- Входной контроль качества.
- Наличие сертификата ISO.

В составе нашей компании организован Конструкторский отдел, призванный помогать разработчикам, и инженерам.

Конструкторский отдел помогает осуществить:

- Регистрацию проекта у производителя компонентов.
- Техническую поддержку проекта.
- Защиту от снятия компонента с производства.
- Оценку стоимости проекта по компонентам.
- Изготовление тестовой платы монтаж и пусконаладочные работы.



Тел: +7 (812) 336 43 04 (многоканальный)

Email: org@lifeelectronics.ru