

BGB719N7ESD

Low Noise Amplifier MMIC for FM Radio Applications

Data Sheet

Revision 1.1, 2012-10-30

Edition 2012-10-30

**Published by
Infineon Technologies AG
81726 Munich, Germany**

**© 2013 Infineon Technologies AG
All Rights Reserved.**

Legal Disclaimer

The information given in this document shall in no event be regarded as a guarantee of conditions or characteristics. With respect to any examples or hints given herein, any typical values stated herein and/or any information regarding the application of the device, Infineon Technologies hereby disclaims any and all warranties and liabilities of any kind, including without limitation, warranties of non-infringement of intellectual property rights of any third party.

Information

For further information on technology, delivery terms and conditions and prices, please contact the nearest Infineon Technologies Office (www.infineon.com).

Warnings

Due to technical requirements, components may contain dangerous substances. For information on the types in question, please contact the nearest Infineon Technologies Office.

Infineon Technologies components may be used in life-support devices or systems only with the express written approval of Infineon Technologies, if a failure of such components can reasonably be expected to cause the failure of that life-support device or system or to affect the safety or effectiveness of that device or system. Life support devices or systems are intended to be implanted in the human body or to support and/or maintain and sustain and/or protect human life. If they fail, it is reasonable to assume that the health of the user or other persons may be endangered.

BGB719N7ESD, Low Noise Amplifier MMIC for FM Radio Applications
Revision History: 2012-10-30, Revision 1.1

Page	Subjects (changes since previous revision)
	This data sheet replaces the revision from 2011-10-10. The product itself has not been changed and the device characteristics remain unchanged. Only the product description and information available in the data sheet have been expanded and updated.

Trademarks of Infineon Technologies AG

AURIX™, C166™, CanPAK™, CIPOS™, CIPURSE™, EconoPACK™, CoolMOS™, CoolSET™, CORECONTROL™, CROSSAVE™, DAVE™, DI-POL™, EasyPIM™, EconoBRIDGE™, EconoDUAL™, EconoPIM™, EconoPACK™, EiceDRIVER™, eupec™, FCOS™, HITFET™, HybridPACK™, I²RF™, ISOFACE™, IsoPACK™, MIPAQ™, ModSTACK™, my-d™, NovalithIC™, OptiMOS™, ORIGA™, POWERCODE™, PRIMARION™, PrimePACK™, PrimeSTACK™, PRO-SIL™, PROFET™, RASIC™, ReverSave™, SatRIC™, SIEGET™, SINDRION™, SIPMOS™, SmartLEWIS™, SOLID FLASH™, TEMPFET™, thinQ!™, TRENCHSTOP™, TriCore™.

Other Trademarks

Advance Design System™ (ADS) of Agilent Technologies, AMBA™, ARM™, MULTI-ICE™, KEIL™, PRIMECELL™, REALVIEW™, THUMB™, μVision™ of ARM Limited, UK. AUTOSAR™ is licensed by AUTOSAR development partnership. Bluetooth™ of Bluetooth SIG Inc. CAT-iq™ of DECT Forum. COLOSSUS™, FirstGPS™ of Trimble Navigation Ltd. EMV™ of EMVCo, LLC (Visa Holdings Inc.). EPCOS™ of Epcos AG. FLEXGO™ of Microsoft Corporation. FlexRay™ is licensed by FlexRay Consortium. HYPERTERMINAL™ of Hilgraeve Incorporated. IEC™ of Commission Electrotechnique Internationale. IrDA™ of Infrared Data Association Corporation. ISO™ of INTERNATIONAL ORGANIZATION FOR STANDARDIZATION. MATLAB™ of MathWorks, Inc. MAXIM™ of Maxim Integrated Products, Inc. MICROTEC™, NUCLEUS™ of Mentor Graphics Corporation. MIPI™ of MIPI Alliance, Inc. MIPS™ of MIPS Technologies, Inc., USA. muRata™ of MURATA MANUFACTURING CO., MICROWAVE OFFICE™ (MWO) of Applied Wave Research Inc., OmniVision™ of OmniVision Technologies, Inc. Openwave™ Openwave Systems Inc. RED HAT™ Red Hat, Inc. RFMD™ RF Micro Devices, Inc. SIRIUS™ of Sirius Satellite Radio Inc. SOLARIS™ of Sun Microsystems, Inc. SPANSION™ of Spansion LLC Ltd. Symbian™ of Symbian Software Limited. TAIYO YUDEN™ of Taiyo Yuden Co. TEAKLITE™ of CEVA, Inc. TEKTRONIX™ of Tektronix Inc. TOKO™ of TOKO KABUSHIKI KAISHA TA. UNIX™ of X/Open Company Limited. VERILOG™, PALLADIUM™ of Cadence Design Systems, Inc. VLYNQ™ of Texas Instruments Incorporated. VXWORKS™, WIND RIVER™ of WIND RIVER SYSTEMS, INC. ZETEX™ of Diodes Zetex Limited.

Last Trademarks Update 2011-11-11

Table of Contents

	Table of Contents	4
	List of Figures	5
	List of Tables	6
1	Product Brief	7
2	Features	8
3	Pin Configuration	9
4	Functional Block Diagram	10
5	Maximum Ratings	11
6	Thermal Characteristics	12
7	Operation Conditions	12
8	Electrical Characteristics	13
8.1	DC Characteristics	13
8.1.1	Typical DC Characteristic Curves	13
8.2	AC Characteristics	14
8.2.1	Typical AC Characteristic Curves	14
9	Package Information TSNP-7-6	16

List of Figures

Figure 3-1	Pinning of BGB719N7ESD in TSNP-7-6	9
Figure 4-1	Functional Block Diagram	10
Figure 4-2	Application Board Drawing	10
Figure 6-1	Total Power Dissipation $P_{\text{tot}} = f(T_s)$	12
Figure 8-1	I_{CC} as a function of V_{CC} , $V_{\text{Ctrl}} = 3 \text{ V}$	13
Figure 8-2	Input and Output matching curves	14
Figure 8-3	I_{CC} as a function of T_A	15
Figure 9-1	Package Outline	16
Figure 9-2	Package Footprint	16
Figure 9-3	Marking Description (Marking BGB719N7ESD: AC)	16
Figure 9-4	Tape Dimensions	16

List of Tables

Table 3-1	Pinning Table	9
Table 4-1	Bill of Materials	10
Table 5-1	Maximum Ratings at $T_A = 25\text{ °C}$	11
Table 5-2	ESD Robustness	11
Table 6-1	Thermal Resistance	12
Table 7-1	Operation Conditions at $T_A = 25\text{ °C}$	12
Table 8-1	DC Characteristics at $T_A = 25\text{ °C}$	13
Table 8-2	AC characteristics in the FM Radio LNA Application	14

1 Product Brief

So-called active antenna modules containing a unique passive structure tailored for FM radio and directly interfaced to appropriate amplifier circuitry are rapidly gaining market acceptance in emerging mobile device applications. High gain, low noise amplifiers with small footprints and high robustness against electrostatic discharge are key components for these active antenna designs. The BGB719N7ESD fulfills all the necessary criteria for such active antennas and is able to solve the main problems in embedded active FM antenna designs for handset devices enhancing the receiver sensitivity and consuming less power and less board space.

The device is based on Infineon Technologies' cost effective Silicon Germanium (SiGe:C) technology and comes in a small leadless green package with visible leads enabling optical inspection of soldering quality.

2 Features

- High performance FM Radio LNA with integrated biasing
- Frequency range: 10 MHz to 1 GHz
- Low external parts count
- Super miniature low profile leadless package TSNP-7-6, 1.26 x 1.4 x 0.37 mm
- High gain at only 2.8 mA current consumption
- Integrated active biasing circuit enables stable operating point against temperature-, supply voltage- and processing-variations
- Integrated ESD protection for all pins (1.5 kV, HBM)
- High input compression point
- High input impedance
- Excellent noise figure from latest SiGe:C technology
- Supply voltage: 1.5 V to 4.0 V
- Power-off function
- Pb-free (RoHS compliant) and halogen-free package
- Qualification report according to AEC-Q101 available

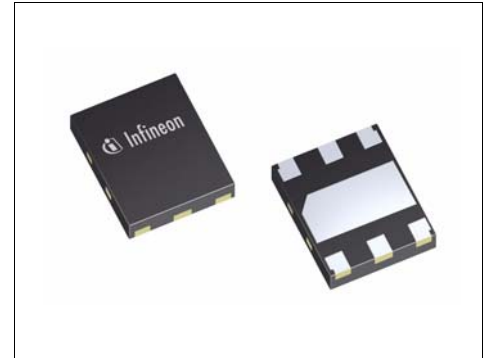

Applications

- Low noise amplifier and active matching for FM reception with small antennas in all kinds of mobile devices such as cell phones, PDAs, portable FM Radio, MP3 players
- Low noise amplifier at 13.56 MHz for Near Field Communication (NFC) applications

Attention: ESD (Electrostatic discharge) sensitive device, observe handling precautions

Product Name	Package	Marking
BGB719N7ESD	TSNP-7-6	AC

3 Pin Configuration

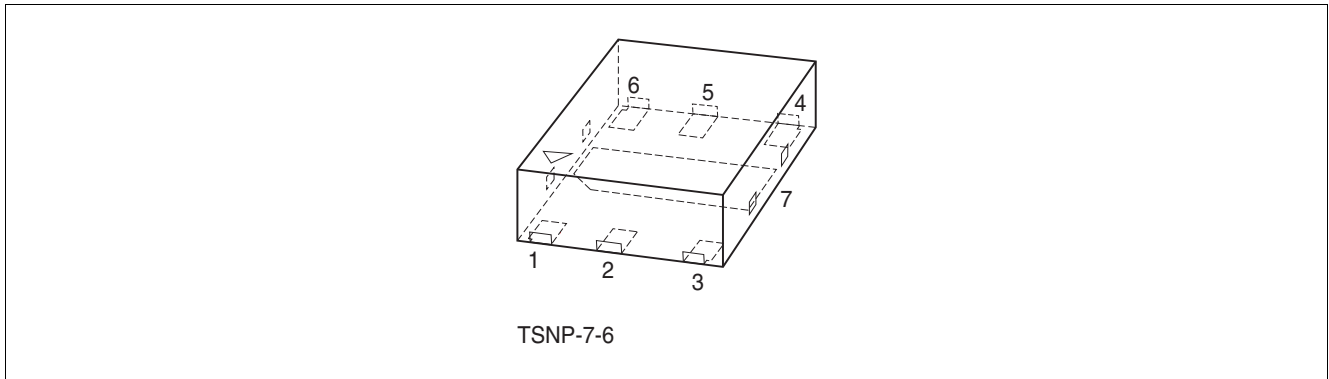

Figure 3-1 Pinning of BGB719N7ESD in TSNP-7-6

Table 3-1 Pinning Table

Pin	Name	Function
1	V_{Ctrl}	On/Off control voltage
2	RF_{IN}	RF input
3	GND_{RF}	RF GND
4	NC	Not connected
5	RF_{OUT}	RF output
6	V_{CC}	Supply voltage
7	GND_{DC}	DC GND

4 Functional Block Diagram

The functional block in **Figure 4-1** shows the principal schematic how the BGB719N7ESD is used in a circuit. The Power On/Off function is controlled by applying V_{Ctrl} . Base- and collector voltages are applied internally.

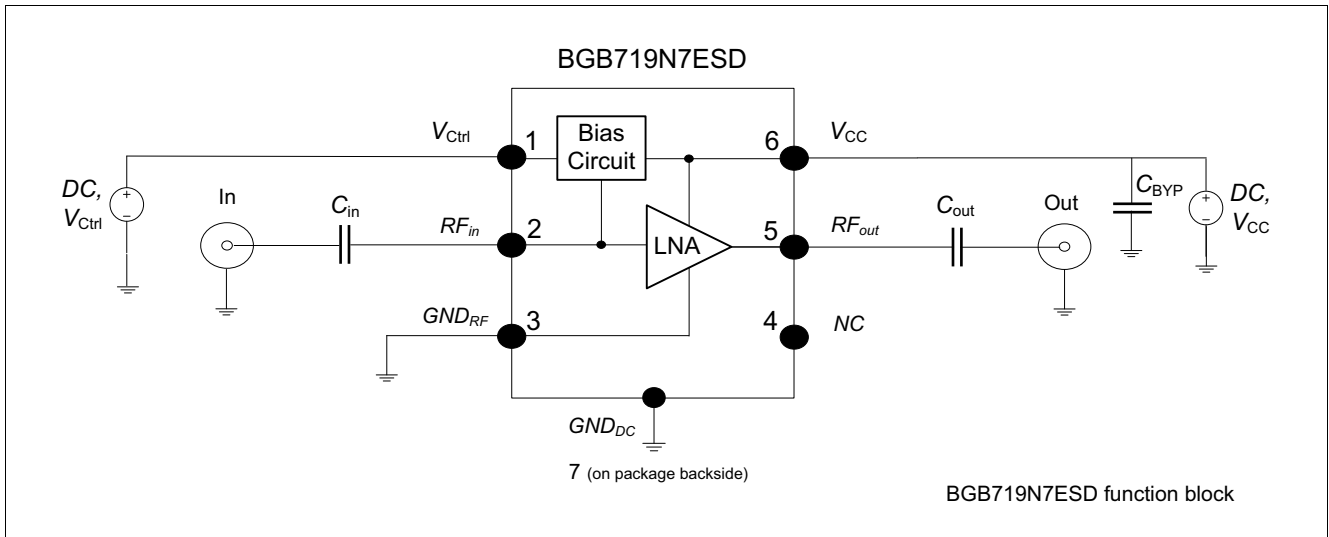

Figure 4-1 Functional Block Diagram

Table 4-1 Bill of Materials

Component	Value	Manufacturer / Type	Function
C_{IN}	330 pF	Various / 0402	DC blocking
C_{OUT}	330 pF	Various / 0402	DC blocking
C_{BYP}	47 nF	Various / 0402	Bypass capacitor

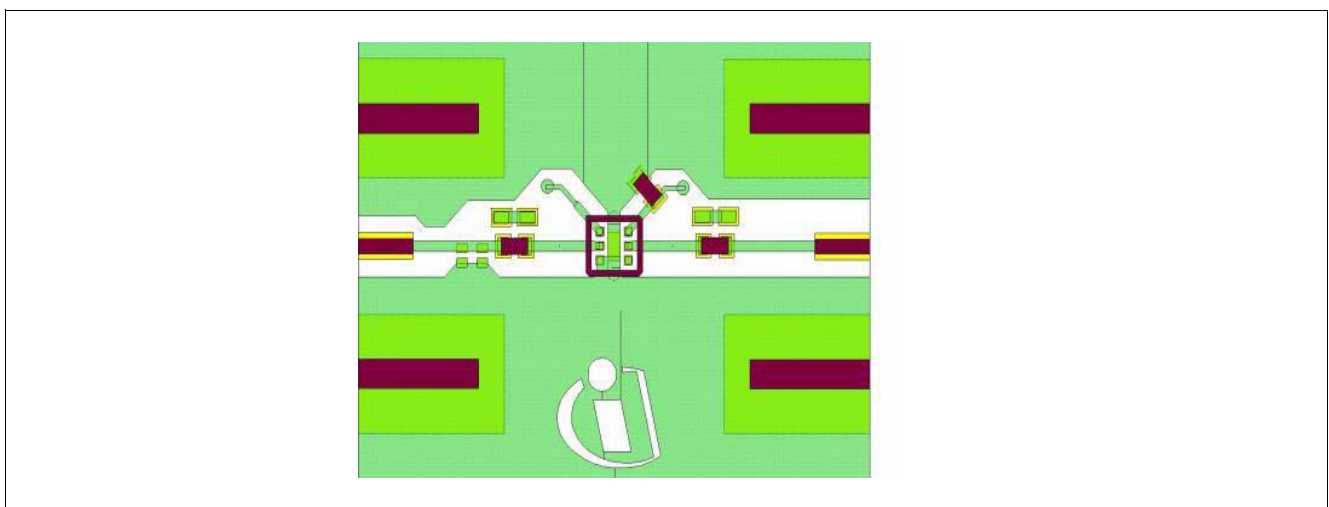

Figure 4-2 Application Board Drawing

5 Maximum Ratings

Table 5-1 Maximum Ratings at $T_A = 25\text{ °C}$

Parameter	Symbol	Values			Unit	Note / Test Condition
		Min.	Typ.	Max.		
Supply voltage	V_{CC}	–	–	4.0	V	–
Supply current at V_{CC} pin	I_{CC}	–	–	25	mA	–
DC current at RF_{IN} Pin	I_B	–	–	3	mA	–
On/Off control voltage	V_{ctrl}	–	–	V_{CC}	V	–
Total power dissipation ¹⁾	P_{tot}	–	–	100	mW	$T_S \leq 112\text{ °C}$
Junction temperature	T_J	–	–	150	°C	–
Storage temperature	T_{Stg}	-55	–	150	°C	–

1) T_S is the soldering point temperature. T_S is measured at the GND pin (7) at the soldering point to the pcb

Table 5-2 ESD Robustness

Testing Model	Standard	Value	Unit
Human Body Model	JESD22-A114-B	1500	V

Attention: Stresses above the max. values listed here may cause permanent damage to the device. Exposure to absolute maximum rating conditions for extended periods may affect device reliability. Maximum ratings are absolute ratings; exceeding only one of these values may cause irreversible damage to the integrated circuit.

6 Thermal Characteristics

Table 6-1 Thermal Resistance

Parameter	Symbol	Values			Unit	Note / Test Condition
		Min.	Typ.	Max.		
Junction - soldering point ¹⁾	R_{thJS}	–	375	–	K/W	

1)For the definition of R_{thJS} please refer to Application Note AN077 (Thermal Resistance Calculation)

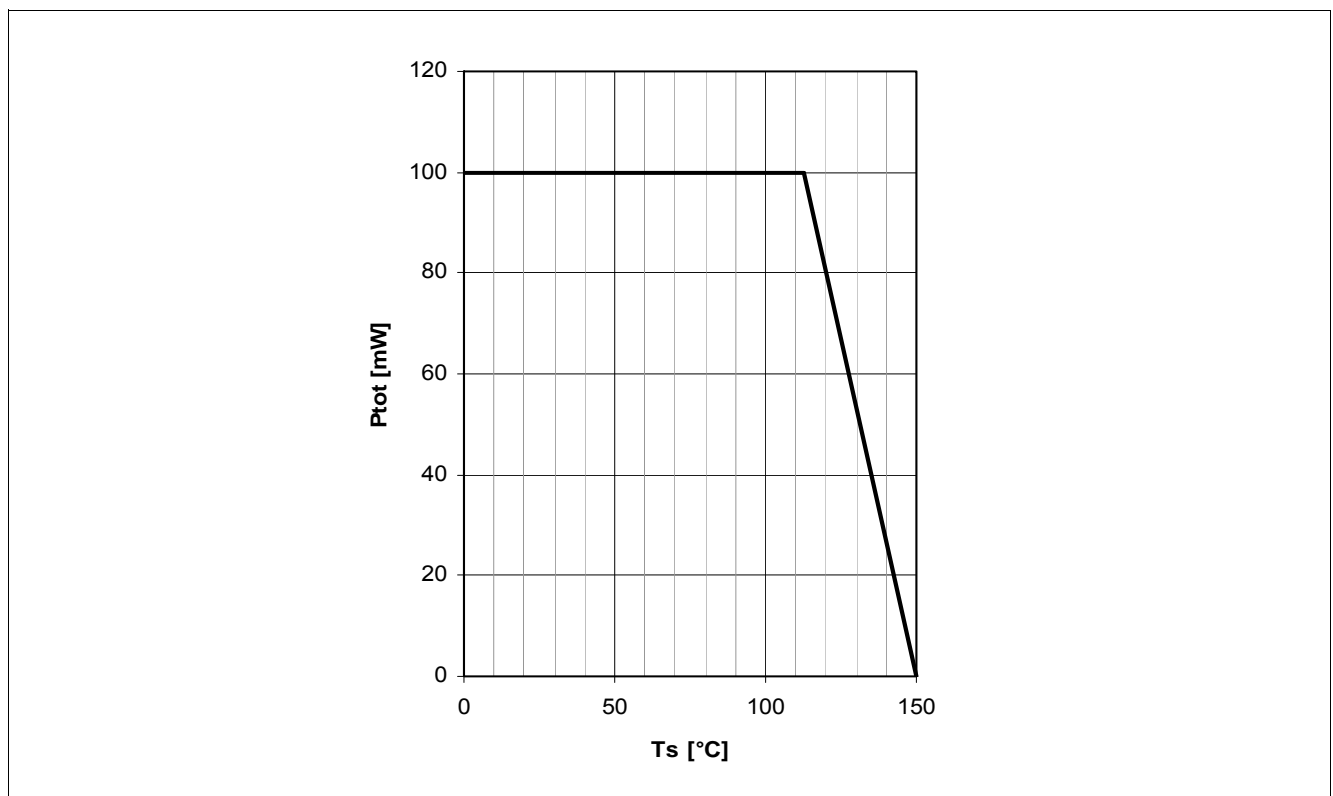
Figure 6-1 Total Power Dissipation $P_{tot} = f(T_s)$

7 Operation Conditions

Table 7-1 Operation Conditions at $T_A = 25\text{ °C}$

Parameter	Symbol	Values			Unit	Note / Test Condition
		Min.	Typ.	Max.		
Supply voltage	V_{CC}	1.5	3.0	4.0	V	–
Voltage Ctrl On/Off pin in On mode	$V_{ctrl-on}$	1.2	3.0	V_{CC}	V	–
Voltage Ctrl On/Off pin in Off mode	$V_{ctrl-off}$	-0.3	0	0.3	V	–

8 Electrical Characteristics

8.1 DC Characteristics

Table 8-1 DC Characteristics at $T_A = 25\text{ }^\circ\text{C}$

Parameter	Symbol	Values			Unit	Note / Test Condition
		Min.	Typ.	Max.		
Supply current	I_{CC}	2.3	2.8	3.3	mA	$V_{CC} = 3\text{ V}$ $V_{ctrl} = 3\text{ V}$ Small signal operation
Supply current in Off mode	I_{CC-off}	–	1	6	μA	$V_{CC} = 4.0\text{ V}$ $V_{ctrl} = 0\text{ V}$
Current into Ctrl On/Off pin in On mode	$I_{ctrl-on}$	–	6	9	μA	$V_{CC} = 3\text{ V}$ $V_{ctrl} = 3\text{ V}$
Current into Ctrl On/Off pin in Off mode	$I_{ctrl-off}$	–	–	0.3	μA	$V_{CC} = 4.0\text{ V}$ $V_{ctrl} = 0\text{ V}$

8.1.1 Typical DC Characteristic Curves

The measurement Setup is an application circuit according to [Figure 4-1](#). $T_A = 25\text{ }^\circ\text{C}$

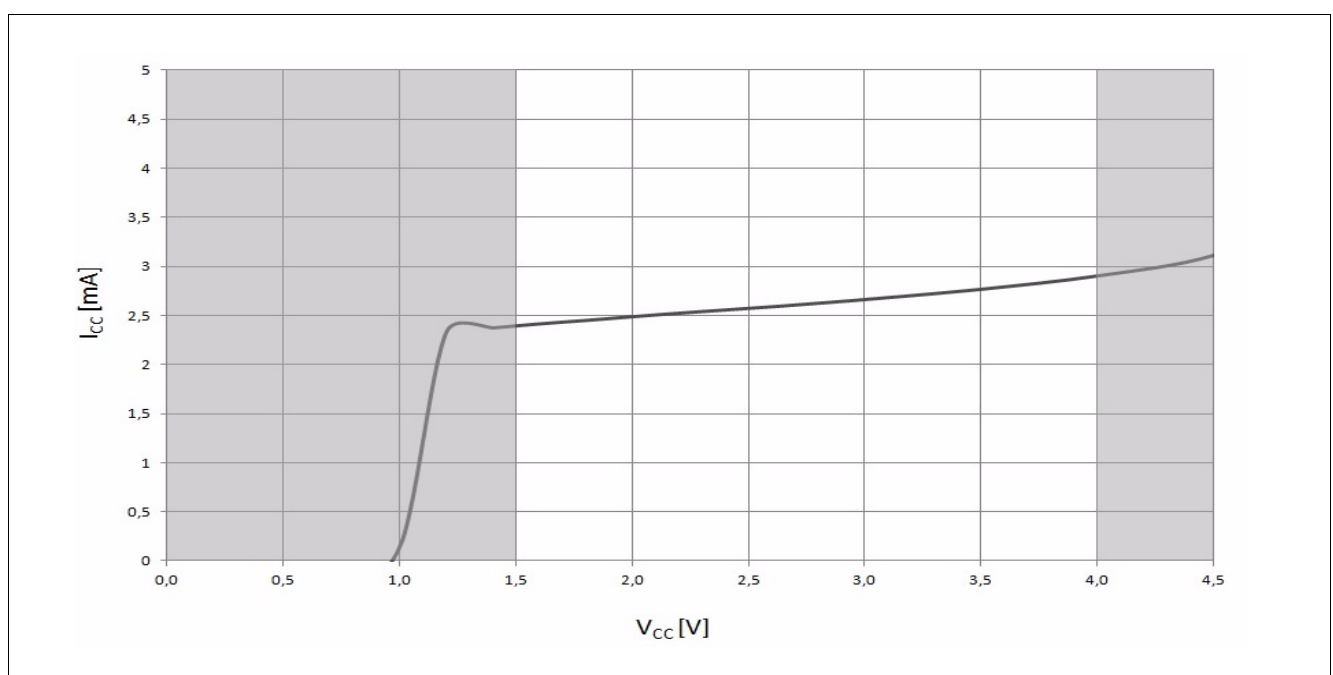
Figure 8-1 I_{CC} as a function of V_{CC} , $V_{ctrl} = 3\text{ V}$

8.2 AC Characteristics

Table 8-2 AC characteristics in the FM Radio LNA Application¹⁾

Parameter	Symbol	Values			Unit	Note / Test Condition
		Min.	Typ.	Max.		
Insertion power gain	$ S_{21} ^2$		13.5		dB	–
Input return loss ²⁾	RL_{IN}	–	0.5 ³⁾	–	dB	–
Output return loss ²⁾	RL_{OUT}	–	11	–	dB	–
Noise figure ⁴⁾	NF_{50}	–	1.2	–	dB	$Z_S = 50 \Omega$
Input 1dB gain compression point ²⁾	IP_{-1dB}	–	-6	–	dBm	–
Input 3rd Order Intercept Point ²⁾	IIP_3	–	-14	–	dBm	$P_{RFIN} = -30 \text{ dBm}$

- 1) As described in AN255, $T_A = 25 \text{ }^\circ\text{C}$, $V_{CC} = 3 \text{ V}$, $V_{Ctrl} = 3 \text{ V}$, $f = 100 \text{ MHz}$
- 2) Verified by random sampling
- 3) High LNA input impedance leads to power matching with high ohmic antennas
- 4) A low pass filter prevents radio broadcast signals from distorting the NF measurement

8.2.1 Typical AC Characteristic Curves

The measurement Setup is an application circuit according to [Figure 4-1](#). $T_A = 25 \text{ }^\circ\text{C}$

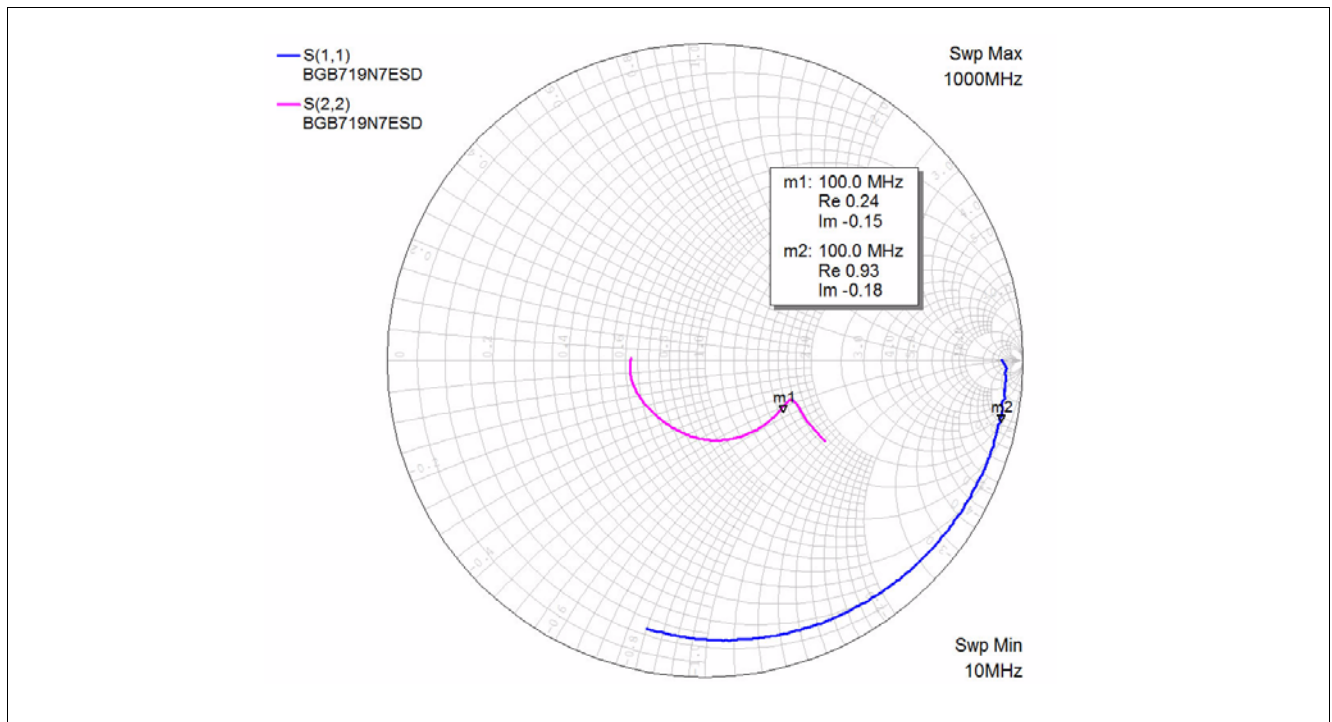

Figure 8-2 Input and Output matching curves

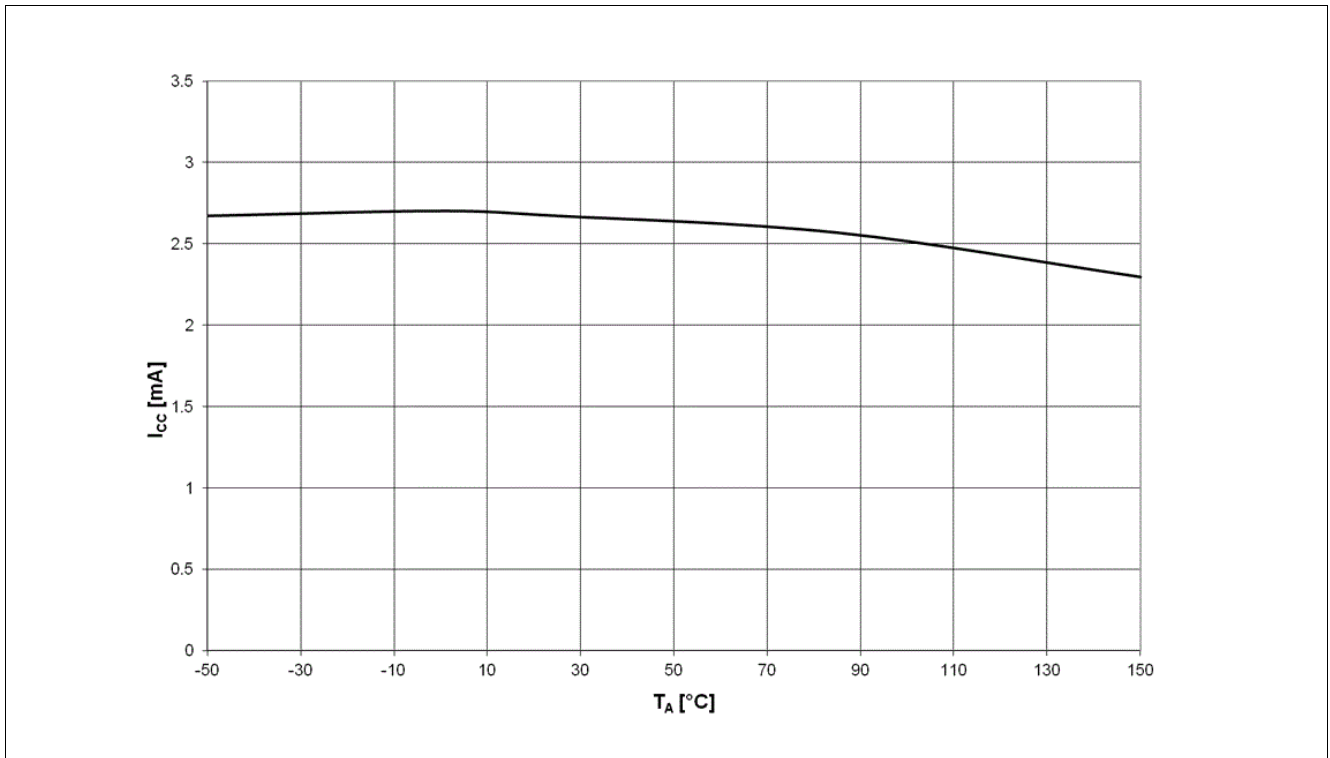

Figure 8-3 I_{CC} as a function of T_A

9 Package Information TSNP-7-6

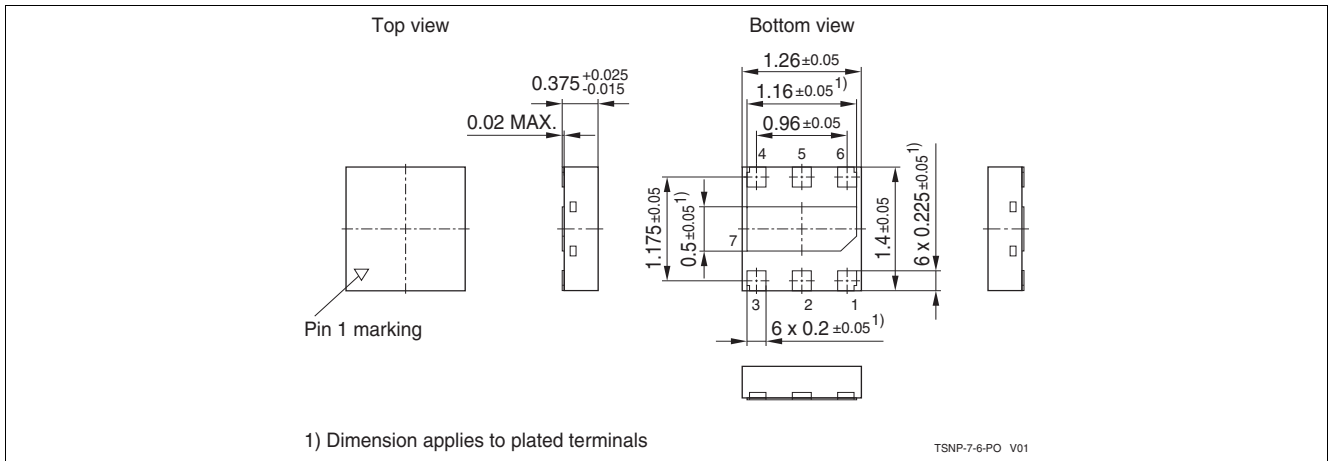

Figure 9-1 Package Outline

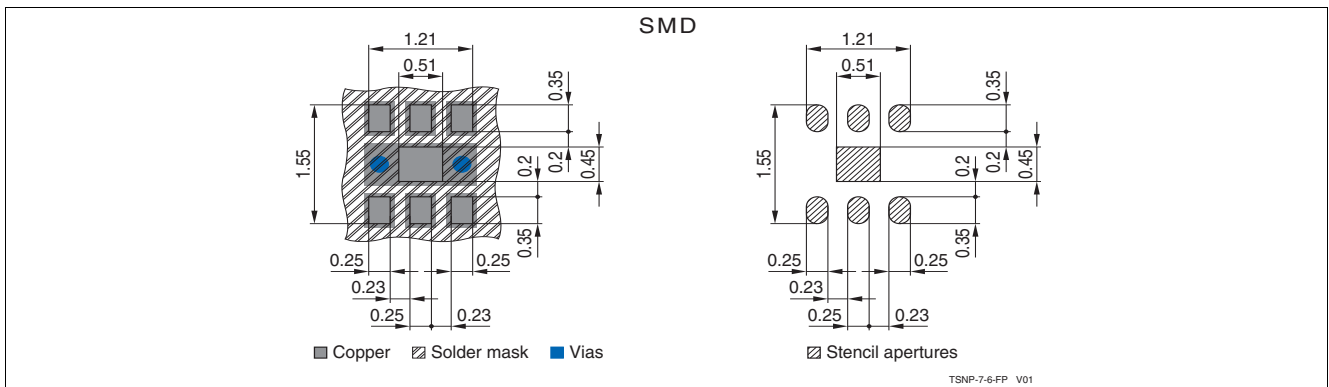

Figure 9-2 Package Footprint

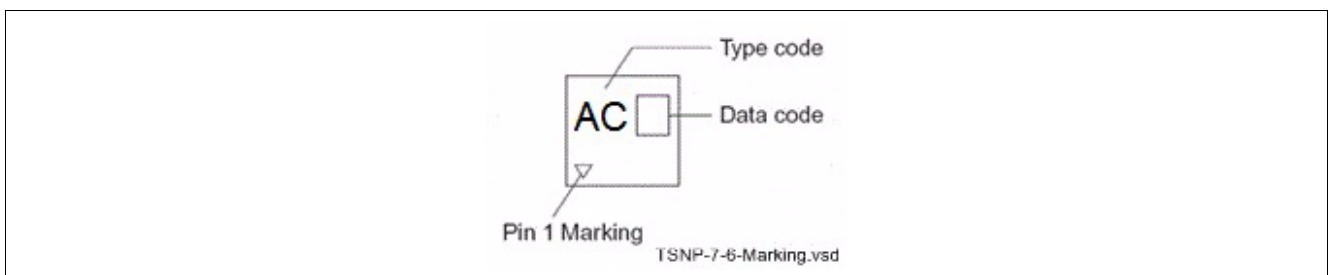

Figure 9-3 Marking Description (Marking BGB719N7ESD: AC)

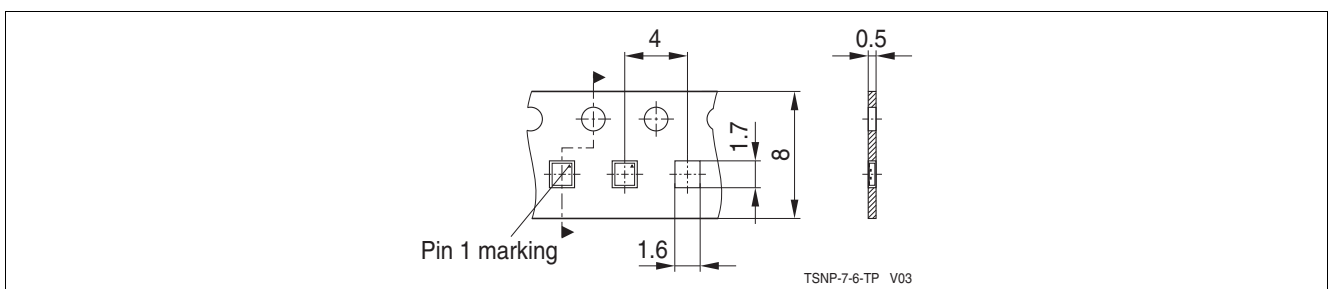

Figure 9-4 Tape Dimensions

www.infineon.com

Published by Infineon Technologies AG

Компания «Life Electronics» занимается поставками электронных компонентов импортного и отечественного производства от производителей и со складов крупных дистрибьюторов Европы, Америки и Азии.

С конца 2013 года компания активно расширяет линейку поставок компонентов по направлению коаксиальный кабель, кварцевые генераторы и конденсаторы (керамические, пленочные, электролитические), за счёт заключения дистрибьюторских договоров

Мы предлагаем:

- Конкурентоспособные цены и скидки постоянным клиентам.
- Специальные условия для постоянных клиентов.
- Подбор аналогов.
- Поставку компонентов в любых объемах, удовлетворяющих вашим потребностям.
- Приемлемые сроки поставки, возможна ускоренная поставка.
- Доставку товара в любую точку России и стран СНГ.
- Комплексную поставку.
- Работу по проектам и поставку образцов.
- Формирование склада под заказчика.
- Сертификаты соответствия на поставляемую продукцию (по желанию клиента).
- Тестирование поставляемой продукции.
- Поставку компонентов, требующих военную и космическую приемку.
- Входной контроль качества.
- Наличие сертификата ISO.

В составе нашей компании организован Конструкторский отдел, призванный помогать разработчикам, и инженерам.

Конструкторский отдел помогает осуществить:

- Регистрацию проекта у производителя компонентов.
- Техническую поддержку проекта.
- Защиту от снятия компонента с производства.
- Оценку стоимости проекта по компонентам.
- Изготовление тестовой платы монтаж и пусконаладочные работы.



Тел: +7 (812) 336 43 04 (многоканальный)

Email: org@lifeelectronics.ru