

### General Description

The 8T349316 is a 2.5V differential clock buffer with sixteen LVDS outputs. The fanout from a differential input to the sixteen LVDS outputs reduces loading on the preceding driver and provides an efficient clock distribution network. The 8T349316 can act as a translator from a differential HSTL, LVPECL, CML or LVDS input to LVDS output signals. A single-ended 3.3V, 2.5V LVCMOS/LVTTL input can also be used to translate to LVDS outputs. The redundant input capability allows for an asynchronous change-over from a primary clock source to a secondary clock source. Selectable reference inputs are controlled by SEL. The 8T349316 outputs can be asynchronously enabled/disabled. When disabled, the outputs will drive to the value selected by the GL pin. Multiple power and grounds reduce noise. The extended temperature range supports wireless infrastructure, telecommunication and networking end equipment requirements. The device is a member of the high-performance clock family from IDT.

### Features

- Clock signal selection and fanout to 16 LVDS outputs
- Guaranteed Low Skew < 50ps (max)
- Low output pulse skew < 125ps (max)
- Propagation delay < 1.75ns (max)
- Up to 1GHz clock signal operation
- Support the following input types: HSTL, LVPECL, HCSL, LVTTL
- Selectable differential input
- Power-down mode
- Full 2.5V power supply
- -40°C to +85°C ambient operating temperature
- Lead-free (RoHS 6) 52-lead VFQFN-P packaging
- Replacement device for the 5T9316

### Block Diagram

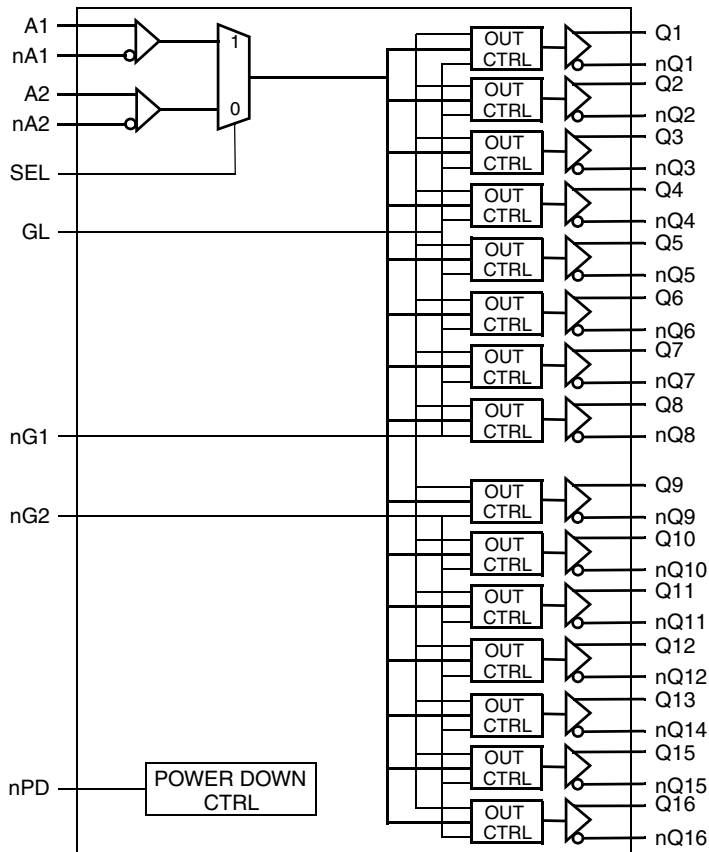

### Pin Assignment

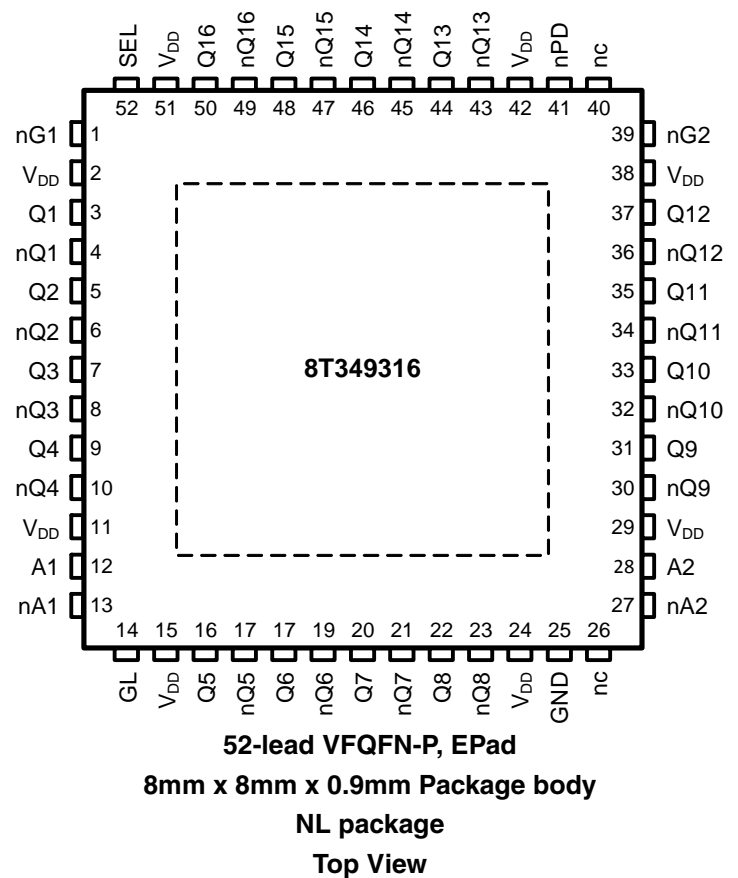

## Pin Description and Pin Characteristic Tables

**Table 1: Pin Descriptions**

Number	Name	Type		Description
1	nG1	Input	-	Output enable control input for the Q[1:8] differential outputs. See <a href="#">Table 3C</a> . LVCMOS/LVTTL interface levels.
2	V <sub>DD</sub>	Power		Positive power supply voltage.
3	Q1	Output		Differential clock output Q1. LVDS interface signals.
4	nQ1	Output		Differential clock output Q1. LVDS interface signals.
5	Q2	Output		Differential clock output Q2. LVDS interface signals.
6	nQ2	Output		Differential clock output Q2. LVDS interface signals.
7	Q3	Output		Differential clock output Q3. LVDS interface signals.
8	nQ3	Output		Differential clock output Q3. LVDS interface signals.
9	Q4	Output		Differential clock output Q4. LVDS interface signals.
10	nQ4	Output		Differential clock output Q4. LVDS interface signals.
11	V <sub>DD</sub>	Power		Positive power supply voltage.
12	A1	Input	-	Differential clock signal input 1.
13	nA1	Input	-	Differential clock signal input 1.
14	GL	Input	-	Control input for the output level for outputs in disable state. See <a href="#">Table 3C</a> and <a href="#">Table 3D</a> . LVCMOS/LVTTL interface levels.
15	V <sub>DD</sub>	Power		Positive power supply voltage.
16	Q5	Output		Differential clock output Q5. LVDS interface signals.
17	nQ5	Output		Differential clock output Q5. LVDS interface signals.
18	Q6	Output		Differential clock output Q6. LVDS interface signals.
19	nQ6	Output		Differential clock output Q6. LVDS interface signals.
20	Q7	Output		Differential clock output Q7. LVDS interface signals.
21	nQ7	Output		Differential clock output Q7. LVDS interface signals.
22	Q8	Output		Differential clock output Q8. LVDS interface signals.
23	nQ8	Output		Differential clock output Q8. LVDS interface signals.
24	V <sub>DD</sub>	Power		Positive power supply voltage.
25	GND	Power		Power Supply Ground.
26	nc	-	-	Not connected. It is recommended to connect this pin to board GND (0V).
27	nA2	Input	-	Differential clock signal input 2.
28	A2	Input	-	Differential clock signal input 2.
29	V <sub>DD</sub>	Power		Positive power supply voltage.
30	nQ9	Output		Differential clock output Q9. LVDS interface signals.
31	Q9	Output		Differential clock output Q9. LVDS interface signals.
32	nQ10	Output		Differential clock output Q10. LVDS interface signals.
33	Q10	Output		Differential clock output Q10. LVDS interface signals.
34	nQ11	Output		Differential clock output Q11. LVDS interface signals.

**Table 1: Pin Descriptions**

Number	Name	Type		Description
35	Q11	Output		Differential clock output Q11. LVDS interface signals.
36	nQ12	Output		Differential clock output Q12. LVDS interface signals.
37	Q12	Output		Differential clock output Q12. LVDS interface signals.
38	V <sub>DD</sub>	Power		Positive power supply voltage.
39	nG2	Input	-	Output enable control input for the Q[9:16] differential outputs. See <a href="#">Table 3D</a> . LVCMOS/LVTTL interface levels.
40	nc	-	-	Not connected. It is recommended to connect this pin to board GND (0V).
41	nPD	Input	-	Device power-down control input. See <a href="#">Table 3B</a> . LVCMOS/LVTTL interface levels.
42	V <sub>DD</sub>	Power		Positive power supply voltage.
43	nQ13	Output		Differential clock output Q13. LVDS interface signals.
44	Q13	Output		Differential clock output Q13. LVDS interface signals.
45	nQ14	Output		Differential clock output Q14. LVDS interface signals.
46	Q14	Output		Differential clock output Q14. LVDS interface signals.
47	nQ15	Output		Differential clock output Q15. LVDS interface signals.
48	Q15	Output		Differential clock output Q15. LVDS interface signals.
49	nQ16	Output		Differential clock output Q16. LVDS interface signals.
50	Q16	Output		Differential clock output Q16. LVDS interface signals.
51	V <sub>DD</sub>	Power		Positive power supply voltage.
52	SEL	Input		Reference input signal select control pin. See <a href="#">Table 3A</a> . LVCMOS/LVTTL interface levels.
—	GND	Power		Exposed package ground supply voltage (GND). Connect to board GND.

**Table 2. Pin Characteristics**

Symbol	Parameter	Test Conditions	Minimum	Typical	Maximum	Units
C <sub>IN</sub>	Input Capacitance	GL, nG1, nG2, nPD, SEL			3	pF

## Logic Truth Tables

**Table 3A: Input Signal Source Select<sup>1</sup>**

SEL	Input Selection
0	A2
1	A1

1. Asynchronous control.

**Table 3B. Device Power-down control<sup>1</sup>**

nPD	Power-down Operation
0	Power-down mode of the entire device. Input and outputs disable and the output voltage is $V_{DD}$ (for each Q1, nQ1 to Q16, nQ16 pair) <sup>2</sup>
1	Normal Operation

1. Asynchronous control.

2. Disable outputs by setting  $nG1 = nG2 = 1$  before entering power-down mode and while in power-down mode. To enter normal device operation, first enable the outputs by setting  $nG1 = nG2 = 0$  before setting  $nPD = 1$ .

**Table 3C. Output Q[1:8] Enable Control<sup>1</sup>**

GL	nG1	Q1 to Q8 Output State
X	0	Enabled (active)
0	1	Disabled, output state is logic low (Q[1:8] = L, nQ[1:8] = H)
1	1	Disabled, output state is logic high (Q[1:8] = H, nQ[1:8] = L)

1. Asynchronous controls.

**Table 3D. Output Q[9:16] Enable Control<sup>1</sup>**

GL	nG2	Q9 to Q16 Output State
X	0	Enabled (active)
0	1	Disabled, output state is logic low (Q[9:16] = L, nQ[9:16] = H)
1	1	Disabled, output state is logic high (Q[9:16] = H, nQ[9:16] = L)

1. Asynchronous controls.

## Absolute Maximum Ratings

NOTE: Stresses beyond those listed under *Absolute Maximum Ratings* may cause permanent damage to the device. These ratings are stress specifications only. Functional operation of the product at these conditions or any conditions beyond those listed in the *DC Characteristics* or *AC Characteristics* is not implied. Exposure to absolute maximum rating conditions for extended periods may affect product reliability.

**Table 4. Absolute Maximum Ratings**

Item	Rating
Supply Voltage, $V_{DD}$	-0.5V to 3.6V
Input Voltage	-0.5V to 3.6V
Output Voltage	-0.5V to $V_{DD} + 0.5V$ and $<3.6V$
Outputs, $I_O$ (LVDS) Continuous Current Surge Current	10mA 15mA
Storage Temperature	-65°C to 150°C
Thermal Junction Temperature, $T_J$	125°C

**Table 5. Recommended Operating Range**

Item	Minimum	Typical	Maximum	Units
Supply Voltage, $V_{DD}$	2.3	2.5	2.7	V
Ambient Temperature	-40		+85	°C

## DC Electrical Characteristics

**Table 6A. Power Supply DC Characteristics,  $V_{DD} = 2.5V \pm 10\%$ ,  $T_A = -40^\circ\text{C}$  to  $+85^\circ\text{C}$**

Symbol	Parameter	Test Conditions	Minimum	Typical	Maximum	Units
$V_{DD}$	Core Supply Voltage		2.3	2.5	2.7	V
$I_{DD}$	Core and Output Power Supply Current	$V_{DD} = 2.7V$ , $f_{REF} = 1\text{GHz}$			360	mA
$I_{DDQ}$	Core and Output Power Supply Current	$V_{DD} = \text{Maximum}$ , A1, nA1 and A2, nA2 at Logic Low Level, Q[1:16] outputs Enabled			350	mA
$I_{DD, PD}$	Power-down Core and Output Power Supply Current	$nPD = 0$			5	mA

**Table 6B. LVCMOS/LVTTL DC Characteristics,  $V_{DD} = 2.5V \pm 10\%$ ,  $T_A = -40^\circ\text{C}$  to  $+85^\circ\text{C}$**

Symbol	Parameter	Test Conditions	Minimum	Typical	Maximum	Units
$I_{IH}$	Input High Voltage	nPD, nG1, nG2, GL $V_{DD} = 2.7V$			150	$\mu\text{A}$
$I_{IL}$	Input Low Voltage	nPD, nG1, nG2, GL $V_{DD} = 2.7V$	-10			$\mu\text{A}$
$V_{IH}$	DC Input High	nPD, nG1, nG2, GL	1.7		3.6	V
$V_{IL}$	DC Input Low	nPD, nG1, nG2, GL	-0.3		0.7	V

**Table 6C. Differential Input DC Characteristics,  $V_{DD} = 2.5V \pm 10\%$ ,  $T_A = -40^\circ\text{C}$  to  $+85^\circ\text{C}$  <sup>1</sup>**

Symbol	Parameter	Test Conditions	Minimum	Typical	Maximum	Units
$I_{IH}$	Input High Voltage	A1, nA1, A2, nA2 $V_{DD} = 2.7V$			150	$\mu\text{A}$
$I_{IL}$	Input Low Voltage	A1, nA1, A2, nA2 $V_{DD} = 2.7V$	-10			$\mu\text{A}$
$V_{PP}$	Peak-to-Peak Voltage <sup>1</sup>		0.15		3.6	V
$V_{CMR}$	Common Mode Input Voltage <sup>1, 2</sup>		0.5		$V_{DD}$	V

1.  $V_{IL}$  should not be less than -0.3V.

2. Common mode input voltage is defined at the crossover point.

**Table 6D. LVDS DC Characteristics,  $V_{DD} = 2.5V \pm 10\%$ ,  $T_A = -40^\circ\text{C}$  to  $+85^\circ\text{C}$**

Symbol	Parameter	Test Conditions	Minimum	Typical	Maximum	Units
$V_{OD}$	Differential Output Voltage		247		454	mV
$\Delta V_{OD}$	$V_{OD}$ Magnitude Change				50	mV
$V_{OS}$	Offset Voltage		1.125	1.2	1.375	V
$\Delta V_{OS}$	$V_{OS}$ Magnitude Change				50	mV
IOS	Outputs Short Circuit Current	$Q_X$ and $nQ_X = 0V$		12	24	mA
IOSD	Differential Outputs Short Circuit Current	$Q_X = nQ_X$		6	12	mA

## AC Electrical Characteristics

**Table 7. AC Characteristics,  $V_{DD} = 2.5V \pm 10\%$ ,  $T_A = -40^\circ\text{C}$  to  $+85^\circ\text{C}$ <sup>1</sup>**

Symbol	Parameter	Test Conditions	Minimum	Typical	Maximum	Units
$f_{OUT}$	Output Frequency	Q[1:16]			1	GHz
$t_{PD}$	Propagation Delay	LH and HL	A1, A2 to Q[1:16]	1.4	1.75	ns
		Output Enable	nG1, nG2 to Q[1:16]		3.5	ns
		Output Disable	nG1, nG2 to Q[1:16]		3.5	ns
		Powered-down	nPD to Q, nQ = $V_{DD}$		100	$\mu\text{s}$
		Powered-down	nPD to Q, nQ = Logic Level defined by the Selected Input		100	$\mu\text{s}$
$t_{sk(o)}$	Output Skew <sup>2 3</sup>	Q[1:16]		12	50	ps
$t_{sk(p)}$	Output Pulse Skew	Q[1:16]		20	125	ps
$t_{sk(pp)}$	Part-to-Part Skew <sup>4</sup>	Q[1:16]			300	ps

1. Electrical parameters are guaranteed over the specified ambient operating temperature range, which is established when the device is mounted in a test socket with maintained transverse airflow greater than 500 lfm. The device will meet specifications after thermal equilibrium has been reached under these conditions.
2. This parameter is defined in accordance with JEDEC standard 65.
3. Defined as skew between outputs at the same supply voltage and with equal load conditions. Measured at the differential cross point.
4. Defined as skew between outputs on different devices operating at the same supply voltage, same temperature, same frequency and with equal load conditions. Using the same type of inputs on each device, the outputs are measured at the differential cross point.

## Parameter Measurement Information

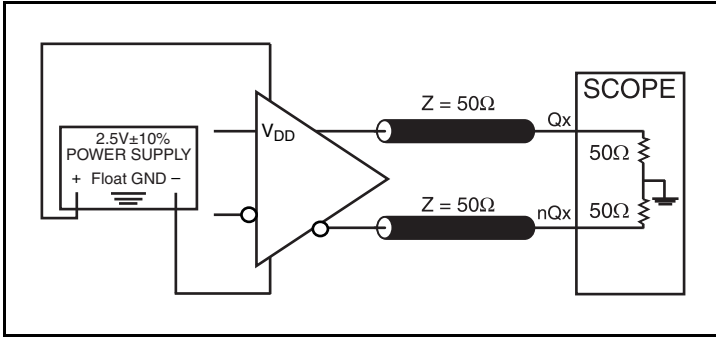

**2.5V LVDS Output Load Test Circuit**

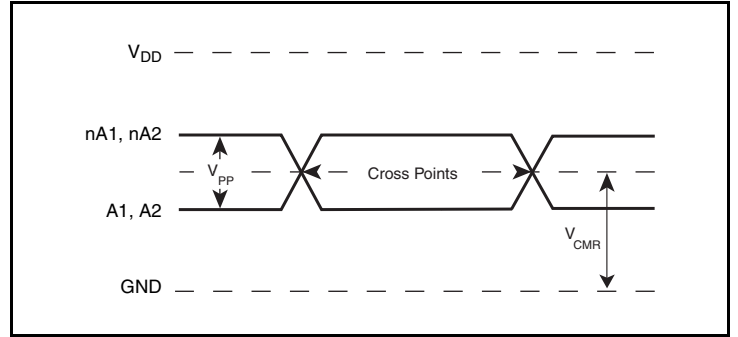

**Differential Input Level**

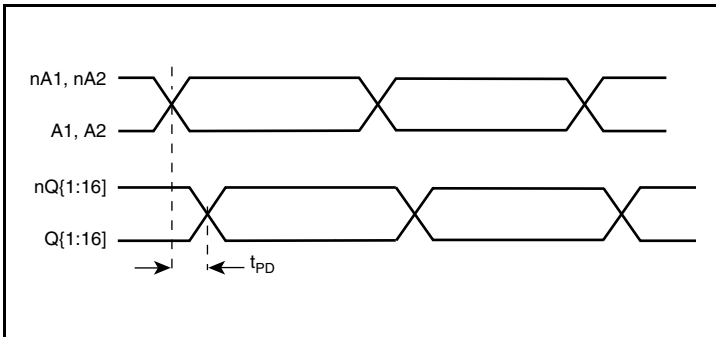

**Propagation Delay**

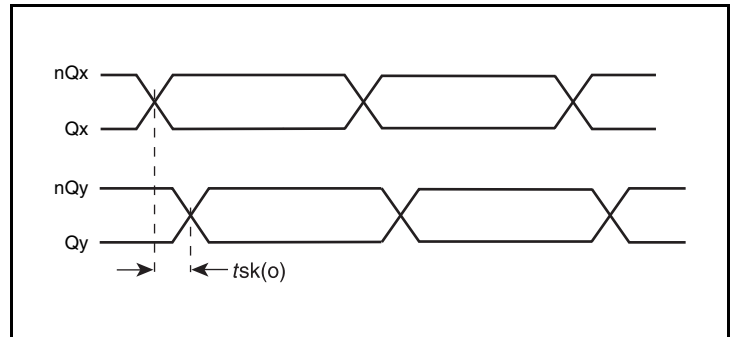

**Output Skew**

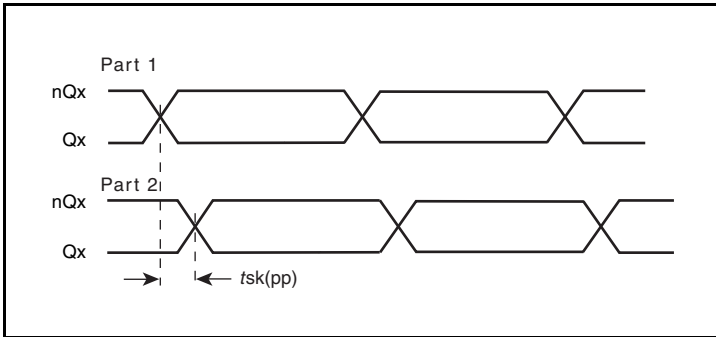

**Part-to-Part Skew**

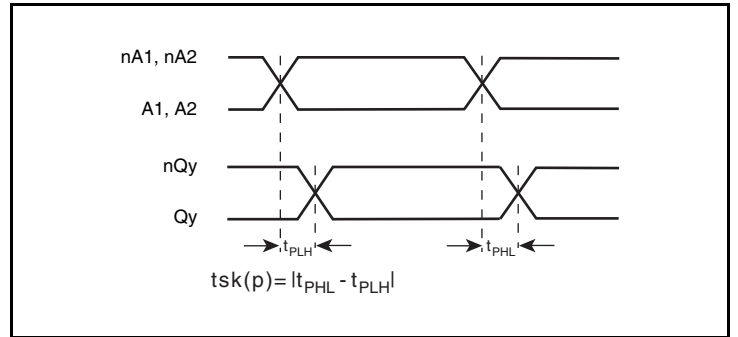

**Pulse Skew**

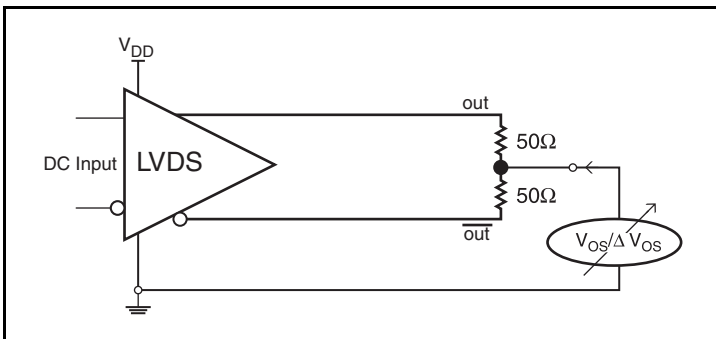

**Offset Voltage Setup**

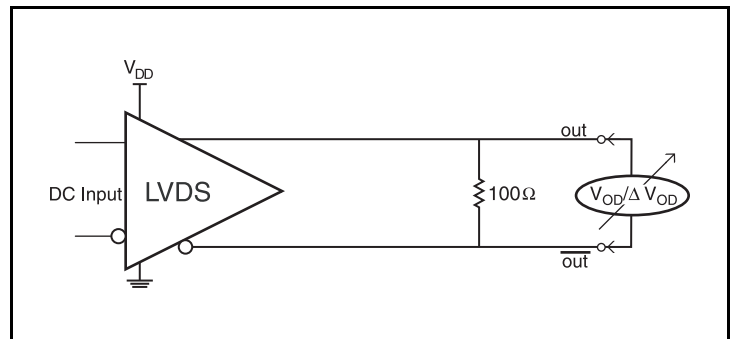

**Differential Output Voltage Setup**



## Applications Information

### Recommendations for Unused Input and Output Pins

#### Inputs:

##### **Ax/nAx Clock Inputs**

For applications not requiring the use of the differential input, Ax should be pulled up with a 10k $\Omega$  resistor and nAx pulled down with a 10k $\Omega$  resistor.

##### **LVC MOS Control Pins**

All control pins have internal pullup or pulldown resistors; additional resistance is not required but can be added for additional protection. A 1k $\Omega$  resistor can be used.

#### Outputs:

##### **LVDS Outputs**

All unused LVDS output pairs can be either left floating or terminated with 100 $\Omega$  across. If they are left floating, there should be no trace attached.

## Wiring the Differential Input to Accept Single-Ended Levels

Figure 1 shows how a differential input can be wired to accept single ended levels. The reference voltage  $V_1 = V_{DD}/2$  is generated by the bias resistors R1 and R2. The bypass capacitor (C1) is used to help filter noise on the DC bias. This bias circuit should be located as close to the input pin as possible. The ratio of R1 and R2 might need to be adjusted to position the  $V_1$  in the center of the input voltage swing. For example, if the input clock swing is 2.5V and  $V_{DD} = 3.3V$ , R1 and R2 value should be adjusted to set  $V_1$  at 1.25V. The values below are for when both the single ended swing and  $V_{DD}$  are at the same voltage. This configuration requires that the sum of the output impedance of the driver ( $R_o$ ) and the series resistance ( $R_s$ ) equals the transmission line impedance. In addition, matched termination at the input will attenuate the signal in half. This can be done in one of two ways. First, R3 and R4 in parallel should equal the transmission line

impedance. For most  $50\Omega$  applications, R3 and R4 can be  $100\Omega$ . The values of the resistors can be increased to reduce the loading for slower and weaker LVCMOS driver. When using single-ended signaling, the noise rejection benefits of differential signaling are reduced. Even though the differential input can handle full rail LVCMOS signaling, it is recommended that the amplitude be reduced. The datasheet specifies a lower differential amplitude, however this only applies to differential signals. For single-ended applications, the swing can be larger, however  $V_{IL}$  cannot be less than  $-0.3V$  and  $V_{IH}$  cannot be more than  $V_{DD} + 0.3V$ . Though some of the recommended components might not be used, the pads should be placed in the layout. They can be utilized for debugging purposes. The datasheet specifications are characterized and guaranteed by using a differential signal.

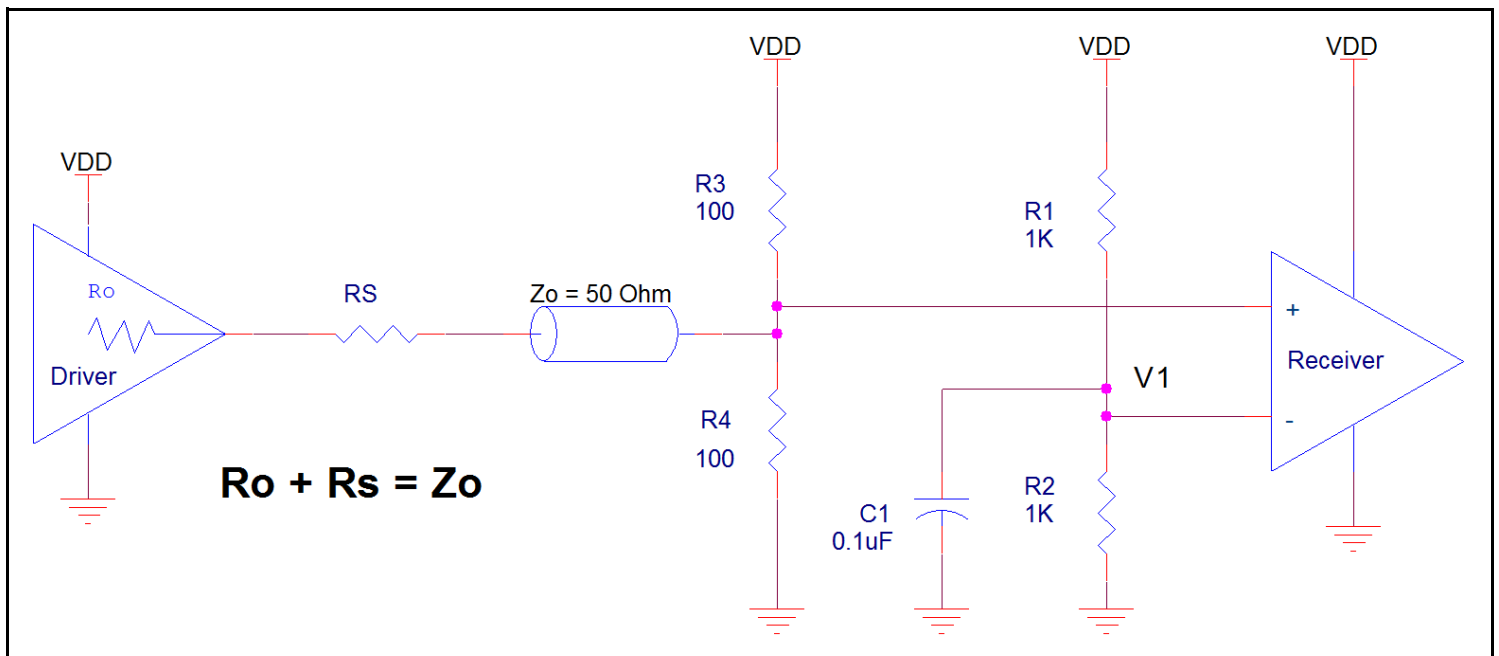

Figure 1. Recommended Schematic for Wiring a Differential Input to Accept Single-ended Levels.

## LVDS Driver Termination

For a general LVDS interface, the recommended value for the termination impedance ( $Z_T$ ) is between  $90\Omega$  and  $132\Omega$ . The actual value should be selected to match the differential impedance ( $Z_0$ ) of your transmission line. A typical point-to-point LVDS design uses a  $100\Omega$  parallel resistor at the receiver and a  $100\Omega$  differential transmission-line environment. In order to avoid any transmission-line reflection issues, the components should be surface mounted and must be placed as close to the receiver as possible. IDT offers a full line of LVDS compliant devices with two types of output structures: current source and voltage source. The standard termination schematic as shown in [Figure 2A](#) can be used

with either type of output structure. [Figure 2B](#), which can also be used with both output types, is an optional termination with center tap capacitance to help filter common mode noise. The capacitor value should be approximately  $50\text{pF}$ . If using a non-standard termination, it is recommended to contact IDT and confirm if the output structure is current source or voltage source type. In addition, since these outputs are LVDS compatible, the input receiver's amplitude and common-mode input range should be verified for compatibility with the output.

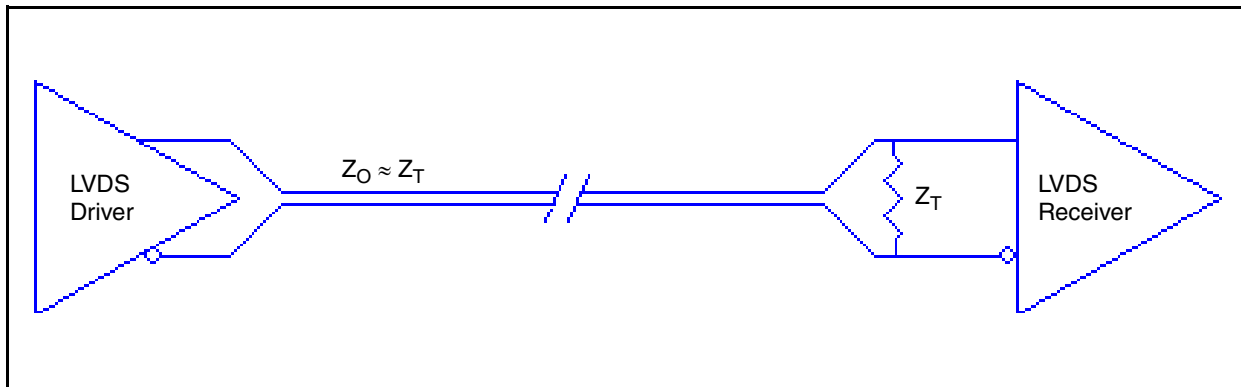

Figure 2A. Standard LVDS Termination

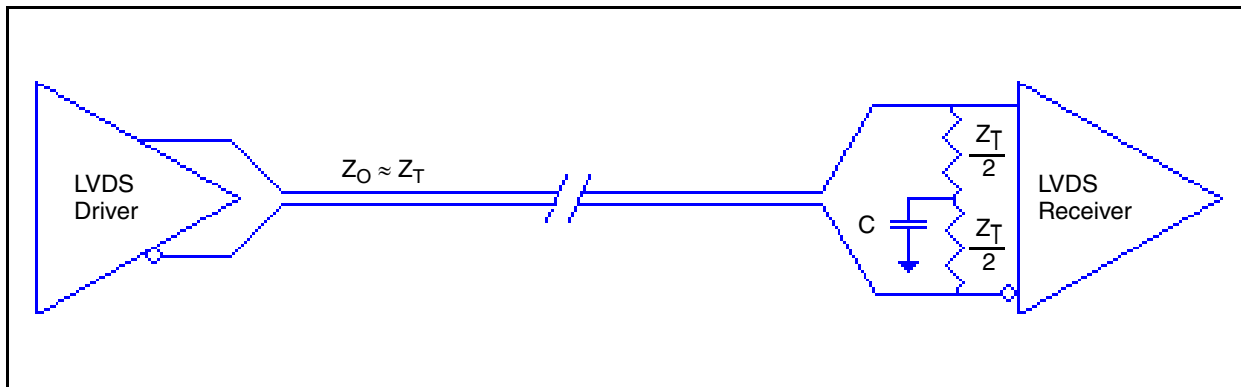

Figure 2B. Optional LVDS Termination

## VFQFN EPAD Thermal Release Path

In order to maximize both the removal of heat from the package and the electrical performance, a land pattern must be incorporated on the Printed Circuit Board (PCB) within the footprint of the package corresponding to the exposed metal pad or exposed heat slug on the package, as shown in [Figure 3](#). The solderable area on the PCB, as defined by the solder mask, should be at least the same size/shape as the exposed pad/slug area on the package to maximize the thermal/electrical performance. Sufficient clearance should be designed on the PCB between the outer edges of the land pattern and the inner edges of pad pattern for the leads to avoid any shorts.

While the land pattern on the PCB provides a means of heat transfer and electrical grounding from the package to the board through a solder joint, thermal vias are necessary to effectively conduct from the surface of the PCB to the ground plane(s). The land pattern must be connected to ground through these vias. The vias act as “heat pipes”. The number of vias (i.e. “heat pipes”) are application specific

and dependent upon the package power dissipation as well as electrical conductivity requirements. Thus, thermal and electrical analysis and/or testing are recommended to determine the minimum number needed. Maximum thermal and electrical performance is achieved when an array of vias is incorporated in the land pattern. It is recommended to use as many vias connected to ground as possible. It is also recommended that the via diameter should be 12 to 13mils (0.30 to 0.33mm) with 1oz copper via barrel plating. This is desirable to avoid any solder wicking inside the via during the soldering process which may result in voids in solder between the exposed pad/slug and the thermal land. Precautions should be taken to eliminate any solder voids between the exposed heat slug and the land pattern. Note: These recommendations are to be used as a guideline only. For further information, please refer to the Application Note on the Surface Mount Assembly of Amkor’s Thermally/Electrically Enhance Leadframe Base Package, Amkor Technology.

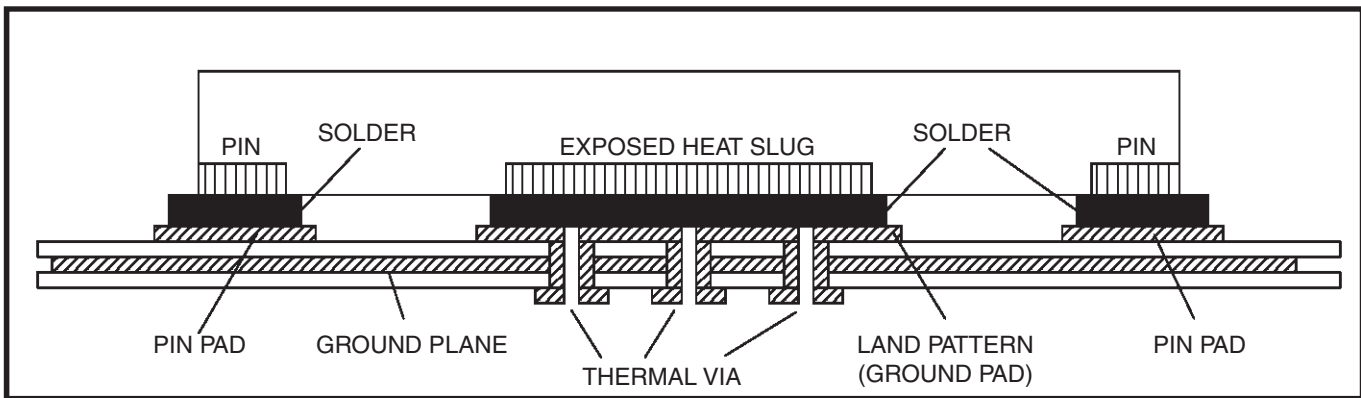

**Figure 3. P.C. Assembly for Exposed Pad Thermal Release Path – Side View (drawing not to scale).**

## Power Considerations

This section provides information on power dissipation and junction temperature for the 8T349316. Equations and example calculations are also provided.

### 1. Power Dissipation.

The total power dissipation for the 8T349316 is the sum of the core power plus the output power dissipation due to the load. The following is the power dissipation for  $V_{DD} = 2.5V + 10\% = 2.700V$ , which gives worst case results.

The maximum current at 85°C is as follows:

$$I_{DD\_MAX} = 360mA$$

- $Power_{(core)MAX} = V_{DD\_MAX} * I_{DD\_MAX} = 2.7V * 360mA = 972mW$

$$Total\ Power\_MAX = 972mW$$

### 2. Junction Temperature.

Junction temperature,  $T_j$ , is the temperature at the junction of the bond wire and bond pad directly affects the reliability of the device. The maximum recommended junction temperature is 125°C. Limiting the internal transistor junction temperature,  $T_j$ , to 125°C ensures that the bond wire and bond pad temperature remains below 125°C.

The equation for  $T_j$  is as follows:  $T_j = \theta_{JA} * Pd\_total + T_A$

$T_j$  = Junction Temperature

$\theta_{JA}$  = Junction-to-Ambient Thermal Resistance

$Pd\_total$  = Total Device Power Dissipation (example calculation is in section 1 above)

$T_A$  = Ambient Temperature

In order to calculate junction temperature, the appropriate junction-to-ambient thermal resistance  $\theta_{JA}$  must be used. Assuming no air flow and a multi-layer board, the appropriate value is 33°C/W per Table 6 below.

Therefore,  $T_j$  for an ambient temperature of 85°C with all outputs switching is:

$$85^\circ C + 0.972W * 33^\circ C/W = 117.1^\circ C. \text{ This is below the limit of } 125^\circ C.$$

This calculation is only an example.  $T_j$  will obviously vary depending on the number of loaded outputs, supply voltage, air flow and the type of board (multi-layer).

**Table 6. Thermal Resistance  $\theta_{JA}$  for 52-Lead VFQFN, Forced Convection**

$\theta_{JA}$ at 0 Air Flow			
Meters per Second	0	1	2
Multi-Layer PCB, JEDEC Standard Test Boards	33.0°C/W	29.76°C/W	28.27°C/W

## Reliability Information

**Table 8.  $\theta_{JA}$  vs. Air Flow Table for a 52-lead VFQFN Package**

$\theta_{JA}$ vs. Air Flow			
Meters per Second	0	1	2
Multi-Layer PCB, JEDEC Standard Test Boards	33.0°C/W	29.76°C/W	28.27°C/W

## Transistor Count

The transistor count for 8T349316 is: 1821

# 52-Lead VFQFN Package Outline

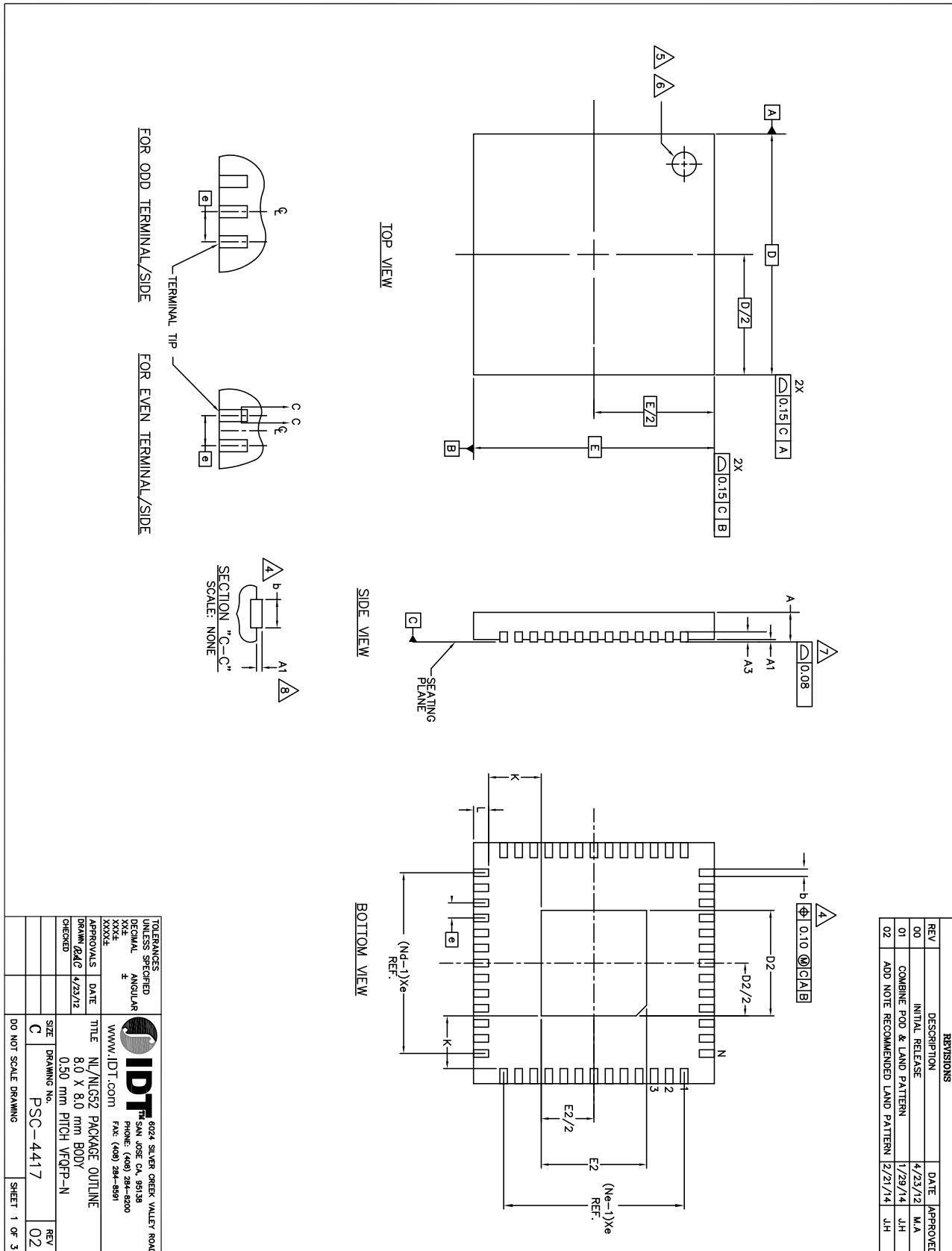

# 52-Lead VFQFN Package Outline, (continued)

S X Y Z	H B L	VARIATION VLD-4			N <sub>0</sub> T <sub>1</sub> E
		MIN.	NOM.	MAX.	
①		0.50	BSC		
N		52			2
Nd		13			2
Ne		13			2
L		0.45	0.50	0.55	
b		0.18	0.25	0.30	4
P		-			
D2		3.4	3.5	3.6	11
E2		3.4	3.5	3.6	11

S X Y Z	H B L	COMMON DIMENSIONS			N <sub>0</sub> T <sub>1</sub> E
		MIN.	NOM.	MAX.	
A		0.80	0.90	1.00	
A1		0.00	0.02	0.05	7
A2		-	0.65	1.00	
A3		-	0.20 REF.		
D		-	8.00 BSC		
E		-	8.00 BSC		
K		0.20	-	-	

**NOTES:**

1. DIMENSIONING & TOLERANCING CONFORM TO ASME Y14.5M. - 1994.
2. N IS THE NUMBER OF TERMINALS.  
Nd IS THE NUMBER OF TERMINALS IN X-DIRECTION &  
Ne IS THE NUMBER OF TERMINALS IN Y-DIRECTION.  
3. ALL DIMENSIONS ARE IN MILLIMETERS.
4. DIMENSION b APPLIES TO PLATED TERMINAL AND IS MEASURED BETWEEN 0.20 AND 0.30mm FROM TERMINAL TIP.
5. THE PIN #1 IDENTIFIER MUST EXIST ON THE TOP SURFACE OF THE PACKAGE BY USING INDENTATION MARK OR OTHER FEATURE OF PACKAGE BODY.
6. EXACT SHAPE AND SIZE OF THIS FEATURE IS OPTIONAL.
7. APPLIED TO EXPOSED PAD AND TERMINALS. EXCLUDE EMBEDDED PART OF EXPOSED PAD FROM MEASURING.
8. APPLIED ONLY FOR TERMINALS.
9. NOT AN ACTUAL IO.
10. THIS OUTLINES CONFORMS TO JEDEC PUBLICATION 95 REGISTRATION MO-220, VARIATION VLD-1, VLD-2, VLD-4 & VLD-5 WITH THE EXCEPTION OF D2 & E2.
11. DIMENSIONS D2 & E2 VARY DEPENDING ON DEVICE, SUPPLIER, ETC.

REVISIONS			
REV	DESCRIPTION	DATE	APPROVED
00	INITIAL RELEASE	4/23/12	M.A
01	COMBINE PAD & LAND PATTERN	1/29/14	J.H
02	ADD NOTE RECOMMENDED LAND PATTERN	2/21/14	J.H

TOLERANCES UNLESS SPECIFIED		<p>9024 SILVER CREEK VALLEY ROAD SAN JOSE CA, 95138 PHONE: (408) 284-8200 FAX: (408) 284-8991</p>
DECIMAL	ANGULAR	
XXXX		
APPROVALS	DATE	
DRWN: <i>BJG</i>	4/23/12	<p>www.IDT.com</p> <p>NL/NLGS2 PACKAGE OUTLINE</p> <p>8.0 X 8.0 mm BODY</p> <p>0.50 mm PITCH VFQFN-N</p>
CHECKED		
SIZE: C	DRAWING NO. PSC-4417	REV: 02
DO NOT SCALE DRAWING		SHEET 2 OF 3



### 52-Lead VFQFN Package Outline, (continued)

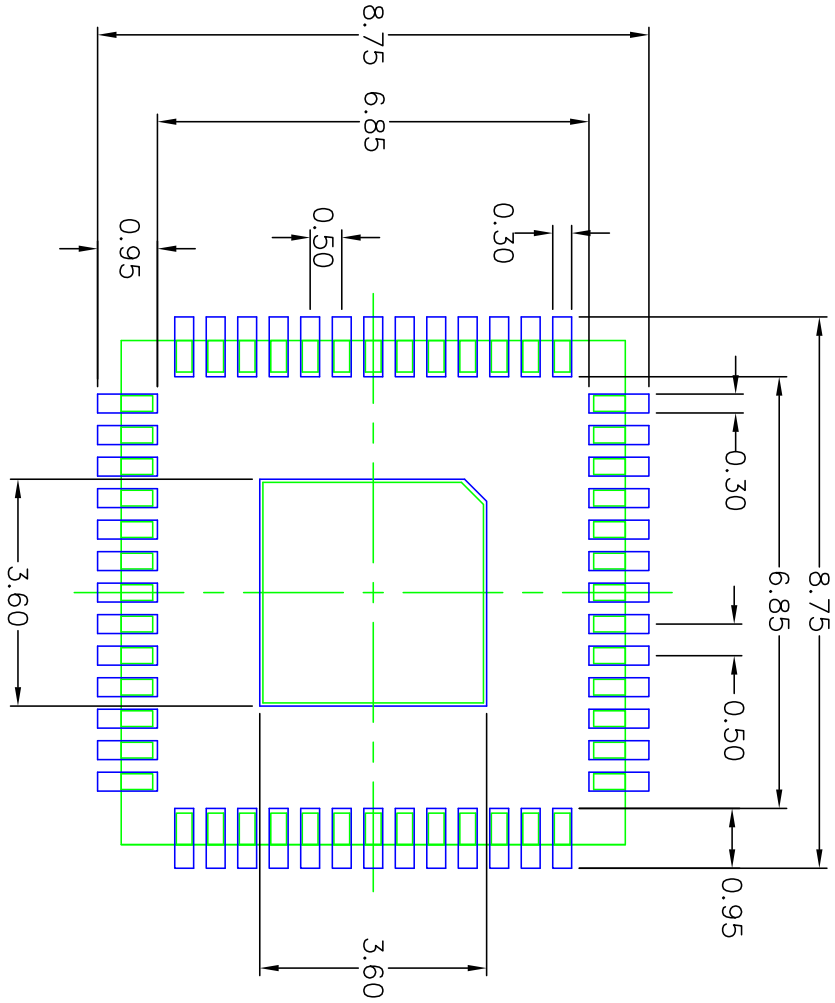

- NOTES:
1. ALL DIMENSIONS ARE IN MM. ANGLES IN DEGREES.
  2. TOP DOWN VIEW. AS VIEWED ON PCB.
  3. COMPONENT OUTLINE IS SHOWN FOR REFERENCE. IN GREEN.
  4. LAND PATTERN IN BLUE. NSMD PATTERN ASSUMED.
  5. LAND PATTERN RECOMMENDATION PER IPC-7351B GENERIC REQUIREMENT FOR SURFACE MOUNT DESIGN AND LAND PATTERN.

REVISIONS			
REV	DESCRIPTION	DATE	APPROVED
00	INITIAL RELEASE	4/23/12	M.A
01	COMBINE PDB & LAND PATTERN	1/29/14	JH
02	ADD NOTE RECOMMENDED LAND PATTERN	2/21/14	JH

TOLERANCES UNLESS SPECIFIED		IDT	
DECIMAL	ANGULAR	9024 SILVER CREEK VALLEY ROAD	
±0.10	±0.5°	SAN JOSE, CA 95138	
±0.05	±0.25°	PHONE: (408) 284-4200	
±0.025	±0.125°	WWW.IDT.COM	
±0.015	±0.0625°	FAX: (408) 284-6591	
APPROVALS	DATE	TITLE	
DESIGNED BY	4/23/12	NL/NIC52 PACKAGE OUTLINE	
CHECKED BY		8.0 X 8.0 mm BODY	
		0.50 mm PITCH VFQFN-N	
SIZE	DRAWING No.	PSC-4417	REV
C			02
DO NOT SCALE DRAWING			SHEET 3 OF 3

## Ordering Information

**Table 9. Ordering Information**

<b>Part/Order Number</b>	<b>Marking</b>	<b>Package</b>	<b>Shipping Packaging</b>	<b>Temperature</b>
8T349316NLGI	IDT8T349316NLGI	"Lead-free" 52-lead VFQFN-P	Tray	-40°C to +85°C
8T349316NLGI8	IDT8T349316NLGI	"Lead-free" 52-lead VFQFN-P	Tape & Reel	-40°C to +85°C



**Corporate Headquarters**  
6024 Silver Creek Valley Road  
San Jose, CA 95138 USA

**Sales**  
1-800-345-7015 or 408-284-8200  
Fax: 408-284-2775  
www.IDT.com

**Tech Support**  
email: [clocks@idt.com](mailto:clocks@idt.com)

DISCLAIMER Integrated Device Technology, Inc. (IDT) and its subsidiaries reserve the right to modify the products and/or specifications described herein at any time and at IDT's sole discretion. All information in this document, including descriptions of product features and performance, is subject to change without notice. Performance specifications and the operating parameters of the described products are determined in the independent state and are not guaranteed to perform the same way when installed in customer products. The information contained herein is provided without representation or warranty of any kind, whether express or implied, including, but not limited to, the suitability of IDT's products for any particular purpose, an implied warranty of merchantability, or non-infringement of the intellectual property rights of others. This document is presented only as a guide and does not convey any license under intellectual property rights of IDT or any third parties.

IDT's products are not intended for use in applications involving extreme environmental conditions or in life support systems or similar devices where the failure or malfunction of an IDT product can be reasonably expected to significantly affect the health or safety of users. Anyone using an IDT product in such a manner does so at their own risk, absent an express, written agreement by IDT.

While the information presented herein has been checked for both accuracy and reliability, Integrated Device Technology (IDT) assumes no responsibility for either its use or for the infringement of any patents or other rights of third parties, which would result from its use. No other circuits, patents, or licenses are implied. This product is intended for use in normal commercial applications. Any other applications, such as those requiring extended temperature ranges, high reliability or other extraordinary environmental requirements are not recommended without additional processing by IDT. IDT reserves the right to change any circuitry or specifications without notice. IDT does not authorize or warrant any IDT product for use in life support devices or critical medical instruments.

Integrated Device Technology, IDT and the IDT logo are registered trademarks of IDT. Product specification subject to change without notice. Other trademarks and service marks used herein, including protected names, logos and designs, are the property of IDT or their respective third party owners.

Copyright ©2014 Integrated Device Technology, Inc.. All rights reserved.

Компания «Life Electronics» занимается поставками электронных компонентов импортного и отечественного производства от производителей и со складов крупных дистрибьюторов Европы, Америки и Азии.

С конца 2013 года компания активно расширяет линейку поставок компонентов по направлению коаксиальный кабель, кварцевые генераторы и конденсаторы (керамические, пленочные, электролитические), за счёт заключения дистрибьюторских договоров

Мы предлагаем:

- Конкурентоспособные цены и скидки постоянным клиентам.
- Специальные условия для постоянных клиентов.
- Подбор аналогов.
- Поставку компонентов в любых объемах, удовлетворяющих вашим потребностям.
- Приемлемые сроки поставки, возможна ускоренная поставка.
- Доставку товара в любую точку России и стран СНГ.
- Комплексную поставку.
- Работу по проектам и поставку образцов.
- Формирование склада под заказчика.
- Сертификаты соответствия на поставляемую продукцию (по желанию клиента).
- Тестирование поставляемой продукции.
- Поставку компонентов, требующих военную и космическую приемку.
- Входной контроль качества.
- Наличие сертификата ISO.

В составе нашей компании организован Конструкторский отдел, призванный помогать разработчикам, и инженерам.

Конструкторский отдел помогает осуществить:

- Регистрацию проекта у производителя компонентов.
- Техническую поддержку проекта.
- Защиту от снятия компонента с производства.
- Оценку стоимости проекта по компонентам.
- Изготовление тестовой платы монтаж и пусконаладочные работы.



Тел: +7 (812) 336 43 04 (многоканальный)

Email: [org@lifeelectronics.ru](mailto:org@lifeelectronics.ru)