

N-channel 600 V, 0.115 Ω typ., 22 A MDmesh M2 Power MOSFET in a PowerFLAT 8x8 HV package

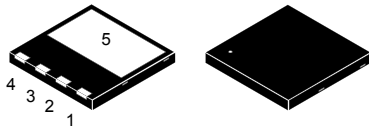

PowerFLAT 8x8 HV

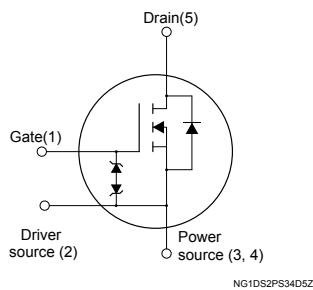

Features

Order code	$V_{DS} @ T_{Jmax}$	$R_{DS(on)max}$	I_D
STL33N60M2	650 V	0.135 Ω	22 A

- Extremely low gate charge
- Excellent output capacitance (C_{OSS}) profile
- 100% avalanche tested
- Zener-protected

Applications

- Switching applications
- LLC converters, resonant converters

Description

This device is an N-channel Power MOSFET developed using MDmesh M2 technology. Thanks to its strip layout and an improved vertical structure, the device exhibits low on-resistance and optimized switching characteristics, rendering it suitable for the most demanding high efficiency converters.



Product status link

[STL33N60M2](#)

Product summary

Order code	STL33N60M2
Marking	33N60M2
Package	PowerFLAT™ 8x8 HV
Packing	Tape & reel

1 Electrical ratings

Table 1. Absolute maximum ratings

Symbol	Parameter	Value	Unit
V_{GS}	Gate-source voltage	± 25	V
$I_D^{(1)}$	Drain current (continuous) at $T_C = 25\text{ }^\circ\text{C}$	22	A
$I_D^{(1)}$	Drain current (continuous) at $T_C = 100\text{ }^\circ\text{C}$	13.8	A
$I_{DM}^{(2)}$	Drain current (pulsed)	88	A
P_{TOT}	Total power dissipation at $T_C = 25\text{ }^\circ\text{C}$	150	W
I_{AR}	Avalanche current, repetitive or not-repetitive (pulse width limited by T_j max)	5	A
E_{AS}	Single pulse avalanche energy (starting $T_j = 25\text{ }^\circ\text{C}$, $I_D = I_{AR}$, $V_{DD} = 50\text{ V}$)	450	mJ
$dv/dt^{(3)}$	Peak diode recovery voltage slope	15	V/ns
$dv/dt^{(4)}$	MOSFET dv/dt ruggedness	50	V/ns
T_{stg}	Storage temperature range	- 55 to 150	$^\circ\text{C}$
T_j	Operating junction temperature range	150	$^\circ\text{C}$

1. The value is limited by package.
2. Pulse width limited by safe operating area.
3. $I_{SD} \leq 22\text{ A}$, $di/dt \leq 400\text{ A}/\mu\text{s}$, $V_{DS(\text{peak})} < V_{(BR)DSS}$, $V_{DD} = 400\text{ V}$.
4. $V_{DS} \leq 480\text{ V}$.

Table 2. Thermal data

Symbol	Parameter	Value	Unit
$R_{thj\text{-case}}$	Thermal resistance junction-case	0.83	$^\circ\text{C}/\text{W}$
$R_{thj\text{-pcb}}^{(1)}$	Thermal resistance junction-pcb	45	$^\circ\text{C}/\text{W}$

1. When mounted on FR-4 board of 1 inch², 2oz Cu.

2 Electrical characteristics

($T_C = 25\text{ °C}$ unless otherwise specified)

Table 3. On /off states

Symbol	Parameter	Test conditions	Min.	Typ.	Max.	Unit
$V_{(BR)DSS}$	Drain-source breakdown voltage	$V_{GS} = 0\text{ V}$, $I_D = 1\text{ mA}$	600			V
I_{DSS}	Zero gate voltage drain current	$V_{GS} = 0\text{ V}$, $V_{DS} = 600\text{ V}$			1	μA
		$V_{GS} = 0\text{ V}$, $V_{DS} = 600\text{ V}$, $T_C = 125\text{ °C}$ ⁽¹⁾			100	μA
I_{GSS}	Gate-body leakage current	$V_{DS} = 0\text{ V}$, $V_{GS} = \pm 25\text{ V}$			± 10	μA
$V_{GS(th)}$	Gate threshold voltage	$V_{DS} = V_{GS}$, $I_D = 250\text{ }\mu\text{A}$	2	3	4	V
$R_{DS(on)}$	Static drain-source on- resistance	$V_{GS} = 10\text{ V}$, $I_D = 11\text{ A}$		0.115	0.135	Ω

1. Defined by design, not subject to production test.

Table 4. Dynamic

Symbol	Parameter	Test conditions	Min.	Typ.	Max.	Unit
C_{iss}	Input capacitance	$V_{DS} = 100\text{ V}$, $f = 1\text{ MHz}$, $V_{GS} = 0\text{ V}$	-	1781	-	pF
C_{oss}	Output capacitance		-	85	-	pF
C_{rss}	Reverse transfer capacitance		-	2.5	-	pF
$C_{oss\text{ eq.}}$ ⁽¹⁾	Equivalent output capacitance	$V_{DS} = 0$ to 480 V , $V_{GS} = 0\text{ V}$	-	135	-	pF
R_G	Intrinsic gate resistance	$f = 1\text{ MHz}$ open drain	-	5.2	-	Ω
Q_g	Total gate charge	$V_{DD} = 480\text{ V}$, $I_D = 26\text{ A}$	-	45.5	-	nC
Q_{gs}	Gate-source charge	$V_{GS} = 0$ to 10 V	-	9.9	-	nC
Q_{gd}	Gate-drain charge	(see Figure 15. Gate charge test circuit)	-	18.5	-	nC

1. $C_{oss\text{ eq.}}$ is defined as a constant equivalent capacitance giving the same charging time as C_{oss} when V_{DS} increases from 0 to 80% V_{DSS} .

Table 5. Switching times

Symbol	Parameter	Test conditions	Min.	Typ.	Max.	Unit
$t_{d(on)}$	Turn-on delay time	$V_{DD} = 300\text{ V}$, $I_D = 13\text{ A}$	-	16	-	ns
t_r	Rise time	$R_G = 4.7\text{ }\Omega$, $V_{GS} = 10\text{ V}$	-	9.6	-	ns
$t_{d(off)}$	Turn-off delay time	(see Figure 14. Switching times test circuit for resistive load and Figure 19. Switching time waveform)	-	109	-	ns
t_f	Fall time		-	9	-	ns

Table 6. Source drain diode

Symbol	Parameter	Test conditions	Min.	Typ.	Max.	Unit
I_{SD}	Source-drain current		-		22	A
$I_{SDM}^{(1)}$	Source-drain current (pulsed)		-		88	A
$V_{SD}^{(2)}$	Forward on voltage	$I_{SD} = 22\text{ A}, V_{GS} = 0\text{ V}$	-		1.6	V
t_{rr}	Reverse recovery time	$I_{SD} = 26\text{ A}, di/dt = 100\text{ A}/\mu\text{s}$	-	375		ns
Q_{rr}	Reverse recovery charge	$V_{DD} = 60\text{ V}$ (see Figure 16. Test circuit for inductive load switching and diode recovery times)	-	5.6		μC
I_{RRM}	Reverse recovery current		-	30		A
t_{rr}	Reverse recovery time	$I_{SD} = 26\text{ A}, di/dt = 100\text{ A}/\mu\text{s}$	-	478		ns
Q_{rr}	Reverse recovery charge	$V_{DD} = 60\text{ V}, T_j = 150\text{ }^\circ\text{C}$ (see Figure 16. Test circuit for inductive load switching and diode recovery times)	-	7.7		μC
I_{RRM}	Reverse recovery current		-	32.5		A

1. Pulse width limited by safe operating area.
2. Pulsed: pulse duration = 300 μs , duty cycle 1.5%.

2.1 Electrical characteristics (curves)

Figure 1. Safe operating area

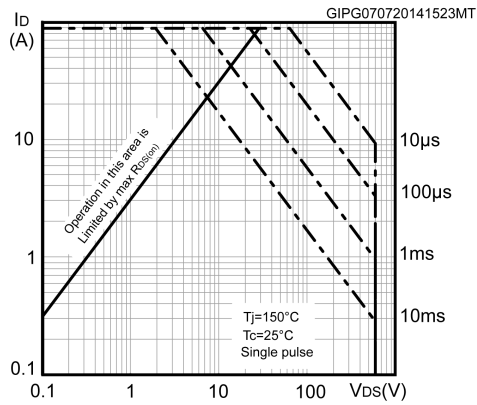

Figure 2. Thermal impedance

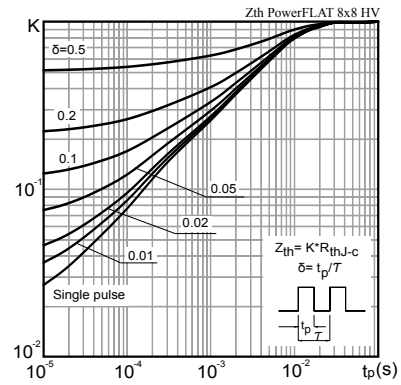

Figure 3. Output characteristics

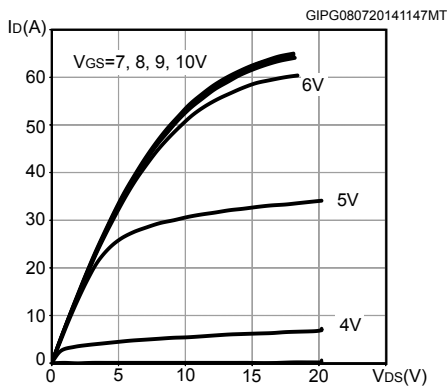

Figure 4. Transfer characteristics

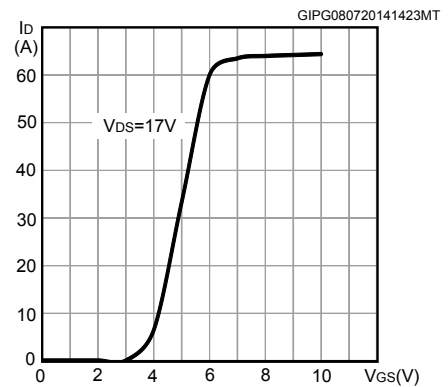

Figure 5. Gate charge vs gate-source voltage

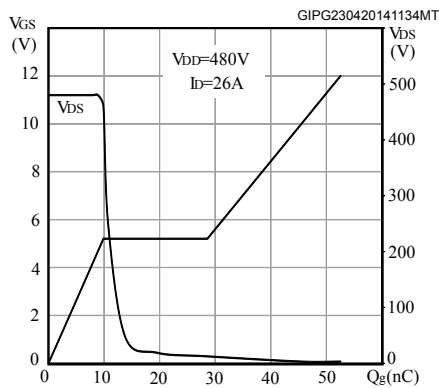

Figure 6. Static drain-source on-resistance

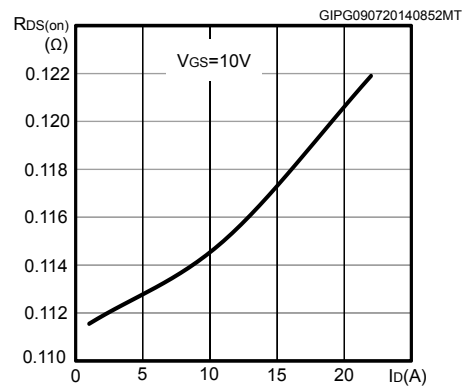

Figure 7. Capacitance variations

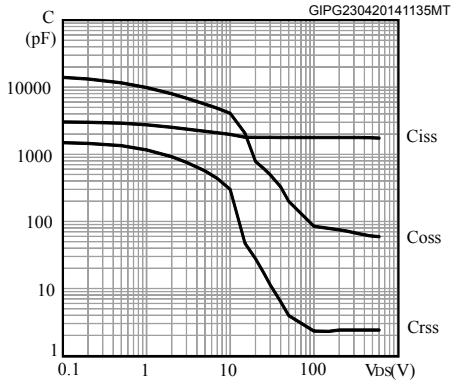

Figure 8. Normalized gate threshold voltage vs temperature

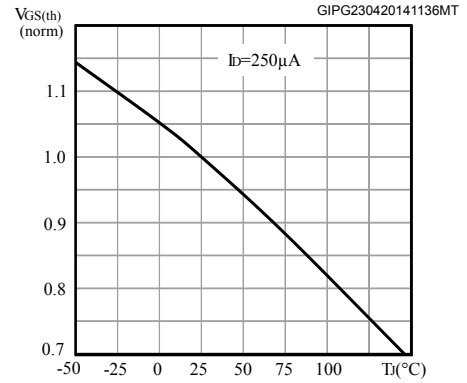

Figure 9. Normalized on-resistance vs temperature

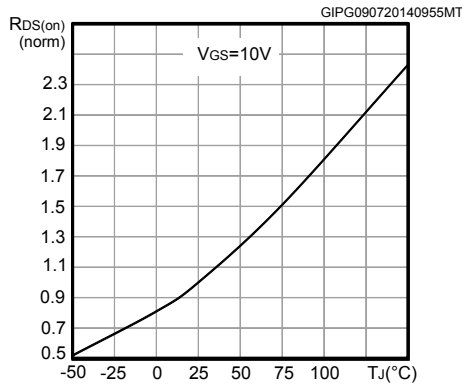

Figure 10. Normalized V(BR)DSS vs temperature

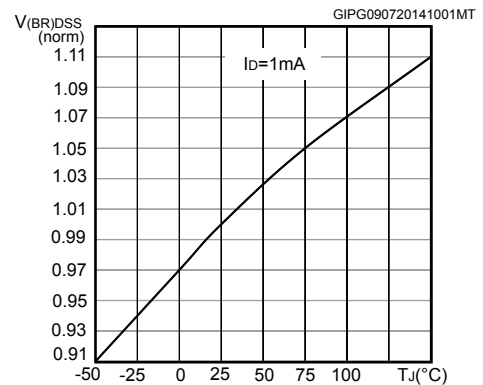

Figure 11. Source-drain diode forward characteristics

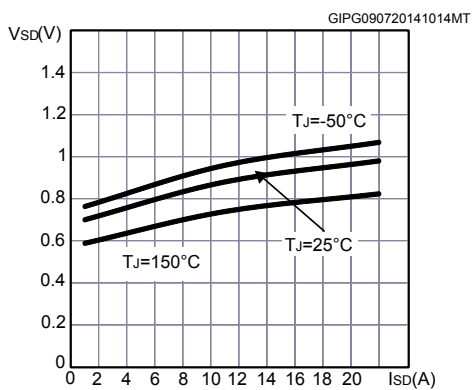

Figure 12. Output capacitance stored energy

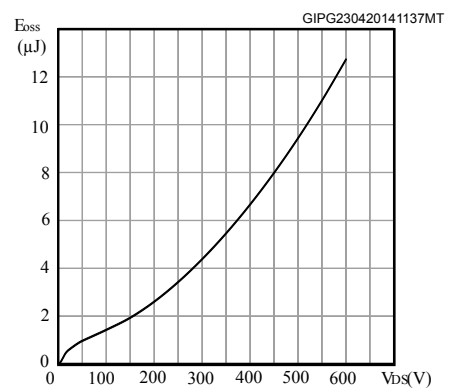
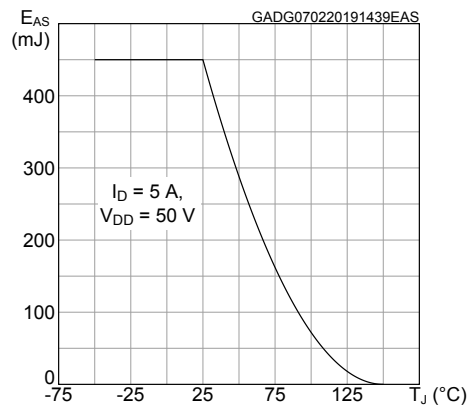
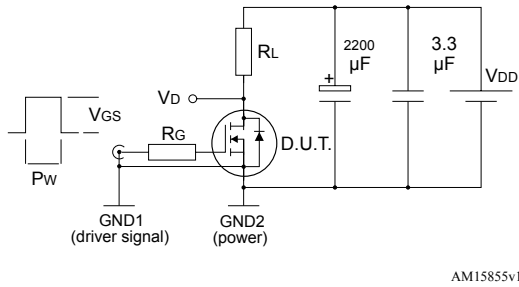
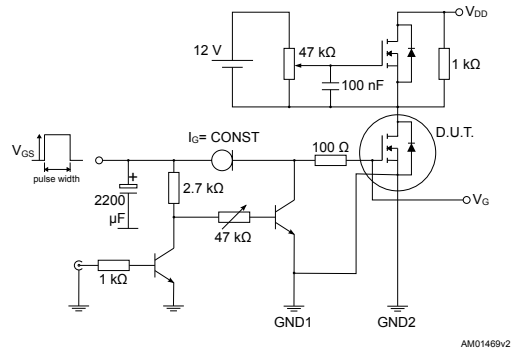
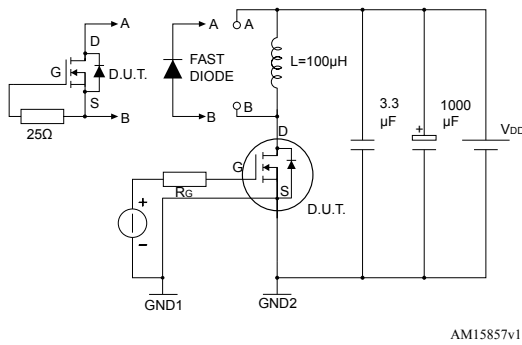
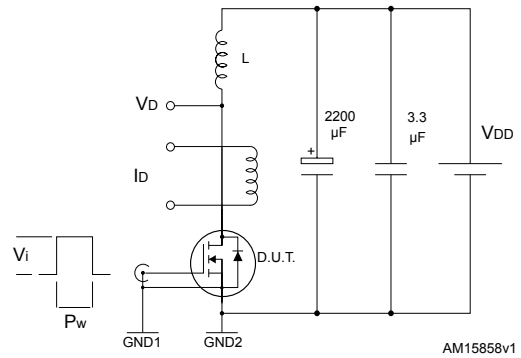
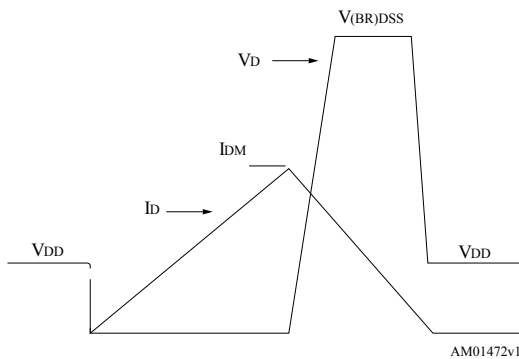
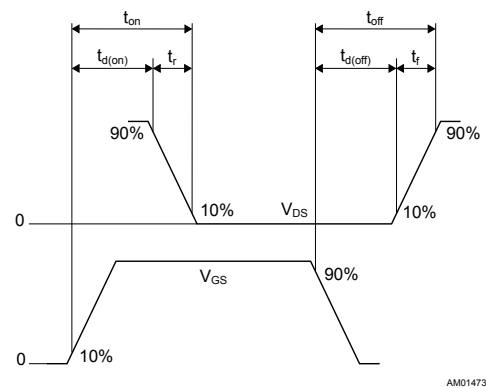

Figure 13. Maximum avalanche energy vs temperature



3 Test circuits

Figure 14. Switching times test circuit for resistive load

Figure 15. Gate charge test circuit

Figure 16. Test circuit for inductive load switching and diode recovery times

Figure 17. Unclamped inductive load test circuit

Figure 18. Unclamped inductive waveform

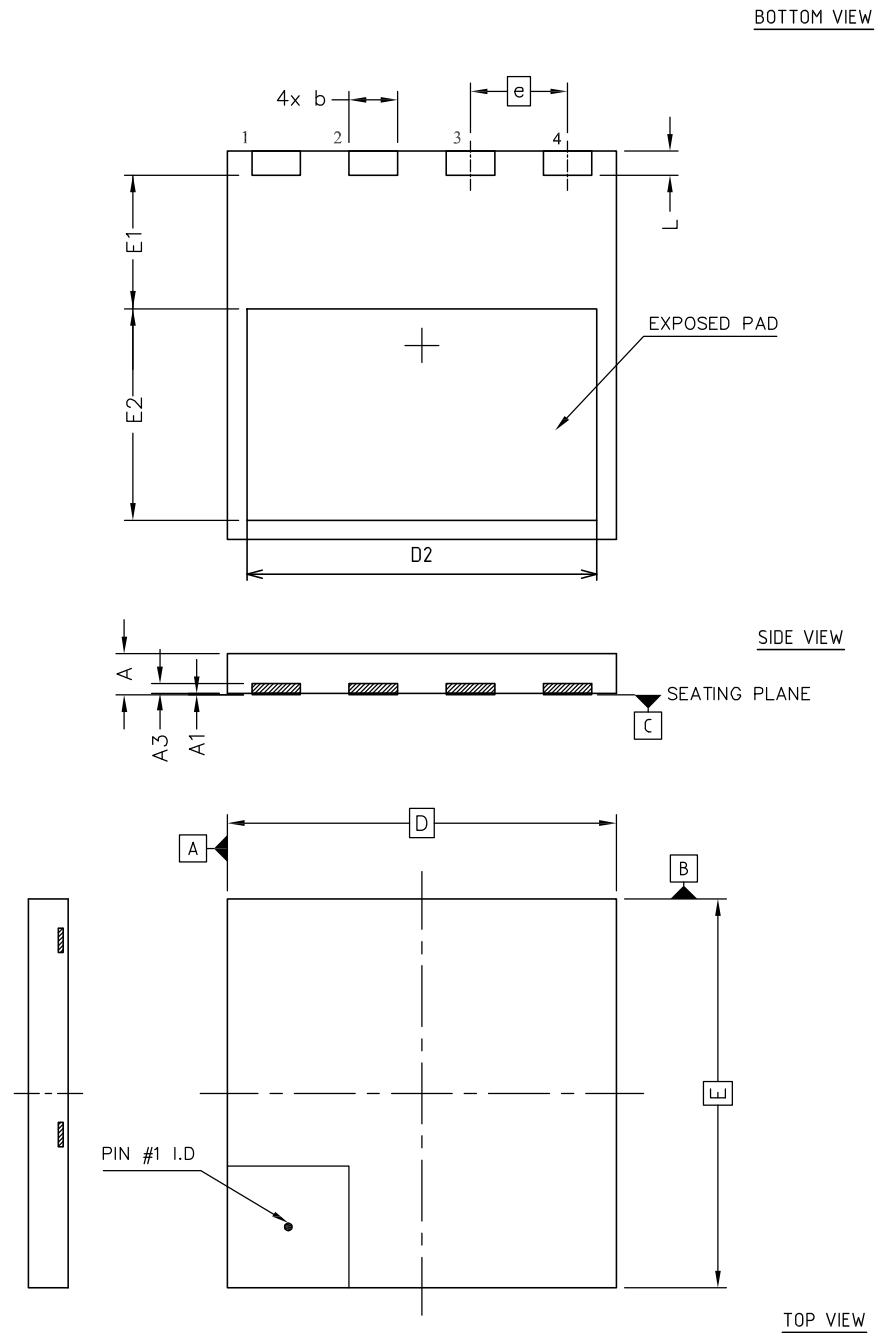
Figure 19. Switching time waveform

4 Package information

In order to meet environmental requirements, ST offers these devices in different grades of **ECOPACK** packages, depending on their level of environmental compliance. ECOPACK specifications, grade definitions and product status are available at: www.st.com. ECOPACK is an ST trademark.

4.1 PowerFLAT 8x8 HV package information

Figure 20. PowerFLAT 8x8 HV package outline



8222871_Rev_4

Table 7. PowerFLAT 8x8 HV mechanical data

Ref.	Dimensions (in mm)		
	Min.	Typ.	Max.
A	0.75	0.85	0.95
A1	0.00		0.05
A3	0.10	0.20	0.30
b	0.90	1.00	1.10
D	7.90	8.00	8.10
E	7.90	8.00	8.10
D2	7.10	7.20	7.30
E1	2.65	2.75	2.85
E2	4.25	4.35	4.45
e	2.00 BSC		
L	0.40	0.50	0.60

Figure 21. PowerFLAT 8x8 HV footprint

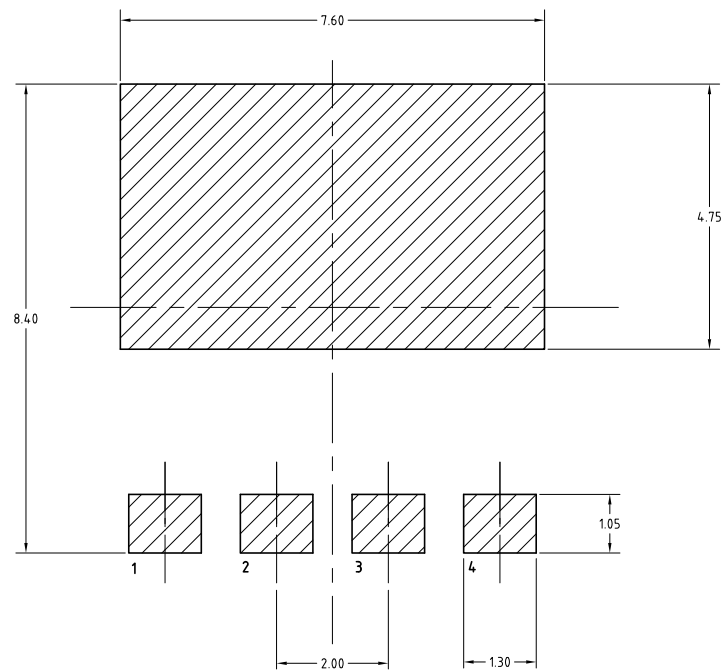

8222871_REV_4_footprint

Note: All dimensions are in millimeters.

4.2 PowerFLAT 8x8 HV packing information

Figure 22. PowerFLAT 8x8 HV tape

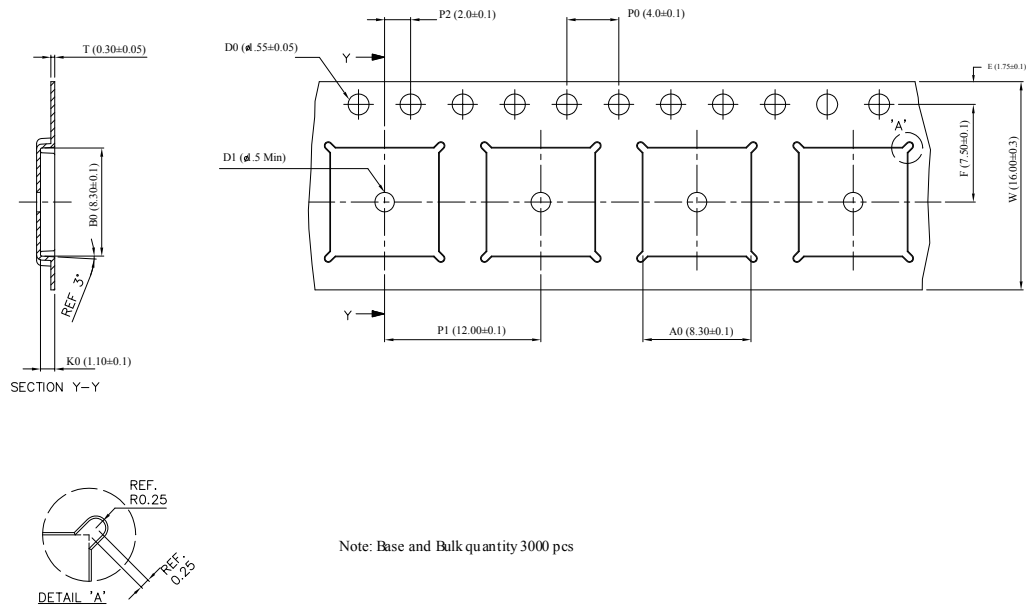

8229819_Tape_revA

Note: All dimensions are in millimeters.

Figure 23. PowerFLAT 8x8 HV package orientation in carrier tape

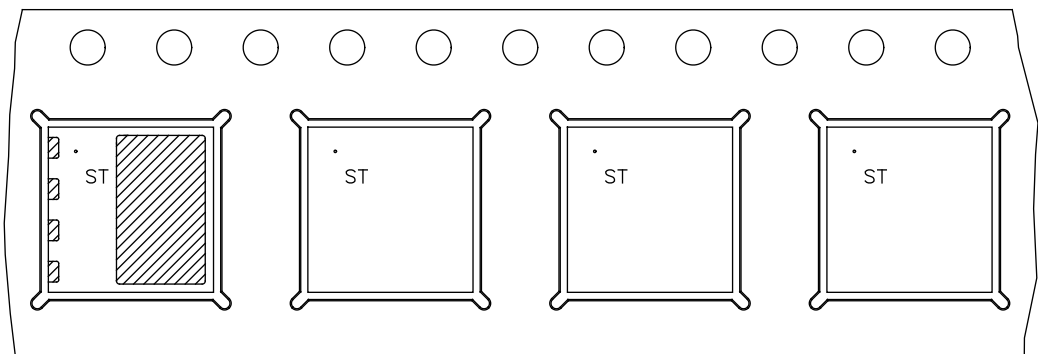

Revision history

Table 8. Document revision history

Date	Revision	Changes
26-Jun-2013	1	First release.
23-Jul-2014	2	<p>Updated the title, the features and the description in cover page. Document status promoted from preliminary data to production data.</p> <p>Updated Figure 1: "Internal schematic diagram", Section 1: "Electrical ratings", Section 2: "Electrical characteristics".</p> <p>Added Section 2.1: "Electrical characteristics (curves)"</p> <p>Updated Section 3: "Test circuits", Section 4.1: "PowerFLAT™ 8x8 HV package mechanical data" ..</p>
20-Nov-2015	3	<p>Updated: cover image and <i>Figure 1: "Internal schematic diagram"</i></p> <p>Table 2: "Absolute maximum ratings", Table 3: "Thermal data" and <i>Table 6: "Switching times"</i></p> <p>Updated: <i>Figure 3: "Thermal impedance"</i></p> <p>Updated: <i>Section 5: "Test circuits"</i></p> <p>Updated: Section 6.1: "PowerFLAT™ 8x8 HV package mechanical data"</p> <p>Minor text changes</p>
11-Jun-2019	4	<p>Update Section 1 Electrical ratings.</p> <p>Added Figure 13. Maximum avalanche energy vs temperature.</p> <p>Minor text changes.</p>

Contents

1	Electrical ratings	2
2	Electrical characteristics	3
2.1	Electrical characteristics (curves)	5
3	Test circuits	8
4	Package mechanical data	9
4.1	PowerFLAT 8x8 HV package information	9
4.2	PowerFLAT 8x8 HV packing information	10
	Revision history	13

IMPORTANT NOTICE – PLEASE READ CAREFULLY

STMicroelectronics NV and its subsidiaries (“ST”) reserve the right to make changes, corrections, enhancements, modifications, and improvements to ST products and/or to this document at any time without notice. Purchasers should obtain the latest relevant information on ST products before placing orders. ST products are sold pursuant to ST’s terms and conditions of sale in place at the time of order acknowledgement.

Purchasers are solely responsible for the choice, selection, and use of ST products and ST assumes no liability for application assistance or the design of Purchasers’ products.

No license, express or implied, to any intellectual property right is granted by ST herein.

Resale of ST products with provisions different from the information set forth herein shall void any warranty granted by ST for such product.

ST and the ST logo are trademarks of ST. For additional information about ST trademarks, please refer to www.st.com/trademarks. All other product or service names are the property of their respective owners.

Information in this document supersedes and replaces information previously supplied in any prior versions of this document.

© 2019 STMicroelectronics – All rights reserved

Компания «Life Electronics» занимается поставками электронных компонентов импортного и отечественного производства от производителей и со складов крупных дистрибьюторов Европы, Америки и Азии.

С конца 2013 года компания активно расширяет линейку поставок компонентов по направлению коаксиальный кабель, кварцевые генераторы и конденсаторы (керамические, пленочные, электролитические), за счёт заключения дистрибьюторских договоров

Мы предлагаем:

- Конкурентоспособные цены и скидки постоянным клиентам.
- Специальные условия для постоянных клиентов.
- Подбор аналогов.
- Поставку компонентов в любых объемах, удовлетворяющих вашим потребностям.
- Приемлемые сроки поставки, возможна ускоренная поставка.
- Доставку товара в любую точку России и стран СНГ.
- Комплексную поставку.
- Работу по проектам и поставку образцов.
- Формирование склада под заказчика.
- Сертификаты соответствия на поставляемую продукцию (по желанию клиента).
- Тестирование поставляемой продукции.
- Поставку компонентов, требующих военную и космическую приемку.
- Входной контроль качества.
- Наличие сертификата ISO.

В составе нашей компании организован Конструкторский отдел, призванный помогать разработчикам, и инженерам.

Конструкторский отдел помогает осуществить:

- Регистрацию проекта у производителя компонентов.
- Техническую поддержку проекта.
- Защиту от снятия компонента с производства.
- Оценку стоимости проекта по компонентам.
- Изготовление тестовой платы монтаж и пусконаладочные работы.



Тел: +7 (812) 336 43 04 (многоканальный)

Email: org@lifeelectronics.ru