

GL Series: Single & Multi Output Switchers

The new GL series provides a broad range of AC/DC power supply solutions that covers power ratings from 25 watts to 500 watts for use in various industrial and medical applications requiring standard footprint size and very high reliability.

These low-profile AC/DC switchers offer universal input voltage with no switches or jumpers, ideal for higher volume worldwide applications.



All models feature:

- Industry standard footprints
- Universal input
- Full power to 50°C
- High demonstrated MTBF
- Automatic overvoltage protection
- Overload protection
- Built-in EMI Filtering
- Extensive safety approvals
- Derated operation to 70°C
- ±2% regulation on main output
- 250 VA and higher VA size enclosed
- Two year limited warranty

Many models feature:

- EN61000-3-2 Compliance
- Supervisory outputs (5 V/12 V)
- Wide-adjustable floating 4th output
- Single wire current share
- Medical approvals
- Remote Sense
- Adjustable main output
- Power Fail and DC Good signals
- Wide-adjustable on single output models

Certifications and Compliances

-  Recognized Component, ITE
 - UL 60950-1
-  Certified, ITE
 - CSA C22.2 CSA 60950-1
- 
 - IEC60950-1

Cover and Bracket Options

- Cover options can be ordered separately. They are designed to simplify mechanical integration of the power supplies into systems and add an extra measure of electrical safety for service personnel.
- Bracket kits can be ordered separately for GL110 series only. It is needed when the cover option is used.



Cover and Bracket Options	
Catalog Number	Description
GLX40	Enclosure kit for the GL20 and GL40
GLX50	Enclosure kit for the GL50 and GL100-M
GLX60	Enclosure kit for the GL60
GLX110-B	Bracket kit for the GL110
GLX110-C	Cover kit for the GL110
GLX120	Enclosure kit for the GLS120 and GLQ120
GLX140-C	Cover kit for the GLQ140
GLX140-CF	Cover with top fan kit for the GLQ140
GLX150-C	Cover kit for the GL150
GLX170-C	Cover kit for the quad output GL170
GLX175-C	Cover kit for the single output GL170
GLX200	Enclosure kit for the GL200-M
GLX250-CEF	Cover end fan kit for the GL250
GLX250-CF	Cover with top fan kit for the GL250/350

Mating Connectors

- Can be ordered separately for units with Molex connection
- Kits include mating housing and pins for input and output connection

Mating Connectors	
Catalog Number	Description
70-841-008	GLX40, GLX50 and GLX60 Mating Connector Kit
70-841-007	GLS110 Mating Connector Kit
70-841-008	GLQ110 Mating Connector Kit
70-841-020	GLS120 Mating Connector Kit
70-841-012	GLQ123 Mating Connector Kit
70-841-017	GLQ142 Mating Connector Kit
70-841-009	GLS150 Mating Connector Kit
70-841-010	GLQ150 Mating Connector Kit
70-841-015	GLQ170 Mating Connector Kit
70-841-016	GLS170 Mating Connector Kit
70-841-005	GLX250 Mating Connector Kit
70-841-011	GLS350 Mating Connector Kit
70-841-024	GLS500 Mating Connector Kit

Specifications

	GL20, GL40	GL50	GL60, GL110	GLQ120, GLS120	GL140	GL150	GL170	GL250, GL350	GL500
Input									
Input Voltage ¹	85 - 264 Vac; 120 - 300 Vdc	90 - 264 Vac 127 - 300 Vdc		85 - 264 Vac 120 - 300 Vdc		85 - 132 Vac or 170 - 264 Vac auto-selected. 220 - 300 Vdc	85 - 264 Vac; 120 - 300 Vdc		85 - 264 Vac
Frequency	47-63 Hz , 400± 40 Hz					47-63 Hz			
Inrush Current	GL20: <15A peak @ 115 Vac; <30A peak @ 230 Vac, cold start @ 25°C. GL40: <18A peak @ 115 Vac; <36A peak @ 230 Vac, cold start @ 25°C	<60A peak @ 230 Vac, cold start @ 25°C	<18A peak @ 115 Vac, <36 A peak @ 230 Vac, cold start @ 25°C	GLQ120: 38 A max., cold start @ 25°C GLS120: 40A max., cold start @ 25°C	38 A max, cold start @ 25°C			GL250: 20 A max., cold start @ 25°C. GL350: 38 A max., cold start @ 25°C.	50 A max., cold start @ 25°C
Efficiency	70% typical at full load	80% - 85% typical at full load	70% typical at full load	GLQ120: 65% typical at full load. GLS120: 80% typical at full load	75% typical at full load				85% typical at full load, nominal line
EMI/RFI	FCC Class B ; CISPR 22 Class B ; EN55022 Class B								
Safety Ground Leakage Current	Non-Medical: <0.5 mA Medical: < 75 µA @ 50/60 Hz, 264 Vac input	Non-medical: <0.5mA Medical: 275 µA @ 50/60 Hz; 264 Vac input for Class I; <0.25mA @ 50/60 Hz; 264 Vac input for Class II (for single output only)	Non-Medical: <0.5 mA Medical: < 75µA @ 50/60 Hz; 264 Vac input	GLQ120: <1 mA @ 50/60 Hz; 264 Vac input. GLS120: 0.5mA @ 50/60 Hz, 264 Vac input	1.0 mA @ 50/60 Hz, 264 Vac input	<0.5 mA @ 50/60 Hz, 264 Vac input	Non-Medical: 0.1 mA Medical: < 250 µA @ 50/60 Hz, 264 Vac input	<0.5 mA @ 50/60 Hz, 264 Vac input	Non-Medical: <0.5 mA Medical: <0.3mA @ 50/60 Hz, 264 Vac input
Output									
Power	Refer to the selection table								
Adjustment Range on Main Output	-5, +10% minimum	±20% minimum for single output only models	GL60: -5, +10% minimum GL110: ±5% on main, 5-25 V on 4 th output	±5% minimum	3.3 - 5.5V on main; -12 - 15V on 3rd output 3.3 - 25 V on 4th output	±5% minimum on main, 5-25 V on 4 th output	2:1 wide ratio minimum	2:1 wide ratio	±5%
Hold-up Time	20 ms @ full load, 115 Vac nominal line	10/20 ms 115/230 Vac Input line	20 ms @ full load, 115 Vac nominal line						
Overload	Short circuit protection on all outputs. Primary overload protection								
Overvoltage Protection	5 V output; 5.7 to 6.7 Vdc. Other outputs 10% to 25% above nominal output	30-50% above nominal output	5 V output; 5.7 - 6.7 Vdc. Other outputs 10% to 25% above nominal output	3.3 V and 5 V output: 20% to 35% above nominal output	Tracks outputs 1, 3 & 4; 10 to 35%	5 V output: 5.7 to 6.7 Vdc. Other outputs 10% to 25% above nominal output	10% to 40% above nominal output	5 V output: 5.7 to 6.7 Vdc. Other outputs 10% to 25% above nominal output	20-35% above nominal output
Remote Sense	Compensates for 0.5 V lead drop minimum; Will operate without remote sense connected, Reverse connection protected								
General									
Temperature ²	Storage: -40°C to +85°C; Operating: 0° to 50°C ambient. Derate each output 2.5% per degree from 50° to 70°C, -20°C start up.								
Electro-magnetic Susceptibility	Designed to meet IEC 801, -2, -3, -4, -5, -6, Level 3 or EN61000-4; -2, -3, -4, -5, -6, -8, -11 Level 3								
Humidity	Operating; non-condensing up to 95% RH								
Vibration	Three orthogonal axes, sweep at 1 oct/min, 5 min. dwell at four major resonances 0.75G peak 5Hz to 500 Hz (2 G peak 8 Hz to 500 Hz for GL500)								
MTBF	>550,000 hours demonstrated at full load and 25°C ambient conditions								
Safety	Non-Medical: EN60950, UL UL60950 E132002, CSA CSA 22.2-234 Level 3 LR53982C, CB Certificate and report; CE Mark (LVD) Medical: UL 2601; CSA 22.2 No. 601.1; EN 60601-1								

Notes:

1. Proper circuit protection required when operating with a DC input voltage. 2. Regulation and ripple may deviate from the spec at -20°C start up.

Selection Table

	Catalog Number	Output 1	Output 2	Output 3	Output 4	Case ³	Pin Assignments ³	Mating Connectors ³
GL20 [40 W] 25 W	GLS22	5 V @ 5 A [8 A] ⁶	-	-	-	1	1A	1B
	GLS23	12 V @ 2.1 A [3.3 A] ⁶	-	-	-			
	GLS24	15 V @ 1.7 A [2.7] ⁶	-	-	-			
	GLT22	5 V @ 3 A [4 A] ⁷	12 V @ 1.5 A [2 A] ⁷	-12 V @ 0.5 A [0.7 A]	-		2A	
	GLT23	5 V @ 4 A [5 A] ⁷	12 V @ 0.5 A [0.7 A]	-12 V @ 0.5 A [0.7 A]	-			
	GLT24	5 V @ 3 A [4 A] ⁷	12 V @ 1.5 A [2 A] ⁷	-5 V @ 0.5 A [0.7 A]	-			
	GLT25	5 V @ 3 A [4 A] ⁷	15 V @ 1.5 A [2 A] ⁷	-15 V @ 0.5 A [0.7 A]	-			
GL40 [55 W] 40 W ¹ [40 W] 25 W ²	GLS42 ⁴	5 V @ 8 A [11 A] ⁶	-	-	-	1	3A	1B
	GLS43 ⁴	12 V @ 3.3 A [4.5] ⁶	-	-	-			
	GLS44 ⁴	15 V @ 2.6 A [3.6 A] ⁶	-	-	-			
	GLS45 ⁴	24 V @ 1.6 A [2.3 A] ⁶	-	-	-		4A	
	GLT42 ⁴	5 V @ 4 A [5 A] ⁷	12 V @ 2 A [2.5 A] ⁷	-12 V @ 0.5 A [0.7 A]	-			
	GLT43	5 V @ 6 A [8 A] ⁷	12 V @ 0.5 A [0.7 A]	-12 V @ 0.5 A [0.7 A]	-			
	GLT44	5 V @ 4 A [5 A] ⁷	12 V @ 2 A [2.5 A] ⁷	-5 V @ 0.5 A [0.7 A]	-			
	GLT45 ⁴	5 V @ 4 A [5 A] ⁷	15 V @ 2 A [2.5 A] ⁷	-15 V @ 0.5 A [0.7 A]	-			
GLT46	5 V @ 4 A [5 A] ⁷	24 V @ 1 A [1.5 A] ⁷	+12 V @ 0.5 A [0.7 A]	-				
GL50 [50 W] 50 W	GLT52 ⁴	5 V @ 8 A ⁷	12 V @ 3 A ⁷	-12 V @ 0.5 A	-	2	5A	2B
	GLT53 ⁴	5 V @ 8 A ⁷	15 V @ 2.4 A ⁷	-15 V @ 0.5 A	-			
	GLT54 ⁴	5 V @ 8 A ⁷	24 V @ 1.5 A ⁷	12 V @ 0.5 A	-			
GL50 [60 W] 60 W	GLS52 ⁴	5 V @ 11 A	-	-	-	3	6A	2B
	GLS53-I ⁵	12 V @ 5A	-	-	-			
	GLS53 ⁴	12 V @ 5 A ⁶	-	-	-			
	GLS54 ⁴	15 V @ 4 A ⁶	-	-	-			
	GLS55 ⁴	24 V @ 2.5 A ⁶	-	-	-			
	GLS58 ⁴	48 V @ 1.25 A ⁶	-	-	-			
GL60 [80 W] 60 W ¹ [60 W] 40 W ²	GLS62	5 V @ 12 A [16 A] ⁶	-	-	-	4	7A	3B
	GLS63 ⁴	12 V @ 5 A [6.7 A] ⁶	-	-	-			
	GLS64 ⁴	15 V @ 4 A [5.3 A] ⁶	-	-	-			
	GLS65 ⁴	24 V @ 2.5 A [3.3 A] ⁶	-	-	-		8A	
	GLT62 ⁴	5 V @ 7 A [8 A] ⁷	12 V @ 3 A [3.5 A] ⁷	-12 V @ 0.7 A [1 A]	-			
	GLT63 ⁴	5 V @ 7 A [8 A] ⁷	15 V @ 2.8 A [3.3 A] ⁷	-15 V @ 0.7 A [1 A]	-			
	GLT64	5 V @ 7 A [8 A] ⁷	12 V @ 3 A [3.5 A] ⁷	-5 V @ 0.7 A [1 A]	-			
	GLT65	5 V @ 7 A [8 A] ⁷	24 V @ 1.5 A [2 A] ⁷	+12 V @ 0.7 A [1 A]	-			
GL110 [110 W] 80 W ¹ [90 W] 70 W ²	GLS114	15 V @ 5.3 A [7.3 A] ⁶	-	-	-	5	9A	5B
	GLS115	24 V @ 3.3 A [4.6 A] ⁶	-	-	-			
	GLQ112	5 V @ 9 A [11 A] ⁸	12 V @ 4.5 A [5 A]	-12 V @ 0.7 A [1 A]	±5-25 V @ 2.5 A [3 A] ⁶		10A	
	GLQ113	5 V @ 9 A [11 A] ⁸	15 V @ 4.5 A [5 A]	-15 V @ 0.7 A [1 A]	±5-25 V @ 2.5 A [3 A] ⁶			
	GLQ114	5 V @ 9 A [11 A] ⁸	12 V @ 4.5 A [5 A]	-12 V @ 0.7 A [1 A]	24 V @ 3.5 A [4.5 A] ⁸			

Notes:

[] Rating with 30 CFM of air

1. Power rating when no cover option is used

2. Power rating when the cover/enclosure option is used

3. Refer to GL Series Dimensions and the sections that follow

4. Add "-M" suffix for the medical model numbers

5. Industrial version - Operating temperature -40°C to 80°C

6. Floating output

7. Approximate minimum loading: 10%

8. Approximate minimum loading: 23%

Selection Table (continued)

	Catalog Number	Output 1	Output 2	Output 3	Output 4	Case ⁵	Pin Assignments ⁵	Mating Connectors ⁵
GLQ120 [120 W] 70 W	GLQ123	3.3 V @ 14 A [25 A]	5 V @ 12.5 A [24 A] ⁹	+12 V @ 1 A [2 A]	-12 V @ 0.5 A [1 A]	6	11A	7B
GLS120 [130 W] 80 W	GLS122	5 V @ 16 A [26 A] ⁸	-	-	-	7	12A	8B
	GLS123	12 V @ 6.6 A [10.8 A] ⁸	-	-	-			
GL140 [145 W] 80 W	GLQ142	5 V @ 12 A [25 A] (3.3 V - 5 V)	12 V @ 5 A [6 A]	-12 V @ 1 A [1.5 A] (-12 V - 15 V)	±3.3-25 V @ 1.5 A [4.5 A] ^{8 10}	8	13A	9B
GL150 [150 W] 110 W ¹ [130 W] 75 W ²	GLS152	5 V @ 22 A [30 A] ⁸	-	-	-	9	14A	10B
	GLS153	12 V @ 9.1 A [12.5 A] ⁸ (12 V - 15 V)	-	-	-			
	GLS155	24 V @ 4.5 A [6.2 A] ⁸ (24 V - 28 V)	-	-	-			
	GLQ152	5 V @ 15 A [22 A] ⁹	12 V @ 2.6 A [8 A] ¹¹	-12 V @ 2 A [2.5 A] ¹¹	±5-25 V @ 2.5 A [3 A] ⁸	10	15A	11B
	GLQ153	5 V @ 15 A [22 A] ⁹	15 V @ 4.8 A [6.4 A] ¹¹	-15 V @ 1.6 A [2 A] ¹¹	±5-25 V @ 2.5 A [3 A] ⁸			
	GLQ154	5 V @ 15 A [22 A] ⁹	12 V @ 6 A [8 A] ¹¹	-12 V @ 2 A [2.5 A] ¹¹	24 V @ 3.5 A [4.5 A] ⁹			
GL170 [175 W] 110 W ¹ [130 W] 75 W ²	GLS172 ⁶	5 V @ 22 A [35 A] ⁸ (2.5 V - 6 V)	-	-	-	11	16A	12B
	GLS173 ⁶	12 V @ 9.1 A [15 A] ⁸ (6 V - 12 V)	-	-	-			
	GLS174 ⁶	15 V @ 7.3 A [12 A] ⁸ (12 V - 24 V)	-	-	-			
	GLS175 ⁶	24 V @ 4.5 A [7.5] ⁸ (24 V - 54 V)	-	-	-			
	GLQ172	5 V @ 15 A [30 A] (3.3 V - 5.5 V)	12 V @ 6 A [8 A] ¹⁰	-12 V @ 0.2 A [3 A] (-12 V - 15 V)	±3.3-25 V @ 2 A [5 A] ⁸	12	17A	13B
GL250 [250 W] ^{3 4}	GLS253-C	12 V (6-12 V) @ [21 A]	-	-	-	13	18A	14B
	GLS255-C	24 V (24-48) @ [10.4 A] ⁸	-	-	-			
	GLQ252-C	5 V @ [35 A] ¹¹	12 V @ [10 A]	-12 V @ [6 A]	±5-25 V @ [6 A] ⁸	14	19A	
	GLQ253-C	5 V @ [35 A] ¹¹	15 V @ [10 A]	-15 V @ [6A]	±5-25 V @ [6 A] ⁸			
GL350 [350 W] ^{3 4}	GLS352-C	5 V (3-6 V) @ [70 A]	-	-	-	15	20A	15B
	GLS353-C	12 V (6-12 V) @ [29.2 A] ⁸	-	-	-			
	GLS354-C	15 V (12-24 V) @ [23.3 A] ⁸	-	-	-			
	GLS355-C	24 V (24-48 V) @ [14.6 A] ⁸	-	-	-			
	GLS355-CEF	24 V (24-48 V) @ [14.6 A] ⁸	-	-	-			
	GLQ352-C	5 V @ [50 A] ¹¹	12 V @ [12 A]	-12 V @ [6 A]	±3.3-24 V @ [6 A] ⁸	16	21A	
	GLQ352-CEF	5 V @ [50 A] ¹¹	12 V @ [12 A]	-12 V @ [6 A]	±3.3-24 V @ [6 A] ⁸			
GL500 [500 W] 200 W	GLS503-CF ⁷	12 V @ 16.6 A [41.7 A]	-	-	-	17	22A	17B
	GLS505-CF ⁷	24 V @ 8.3 A [20.8 A]	-	-	-			
	GLS508-CF ⁷	48 V @ 4.2 A [10.4 A]	-	-	-			

Notes:

[] Rating with 30 CFM of air

- Power rating when no cover option is used
- Power rating when the cover/enclosure option is used
- Optional fan cover, See Table 1
- Optional end fan cover, See Table 1
- Refer to GL Series Dimensions and the sections that follow

- Add "-M" suffix for the medical models numbers.
- Insert (-M) as in GLS 50x-M-CF for medical model numbers
- Floating output
- Approximate minimum loading: 16%
- Approximate minimum loading: 30%
- Approximate minimum loading: 10%

GL Series Dimensions

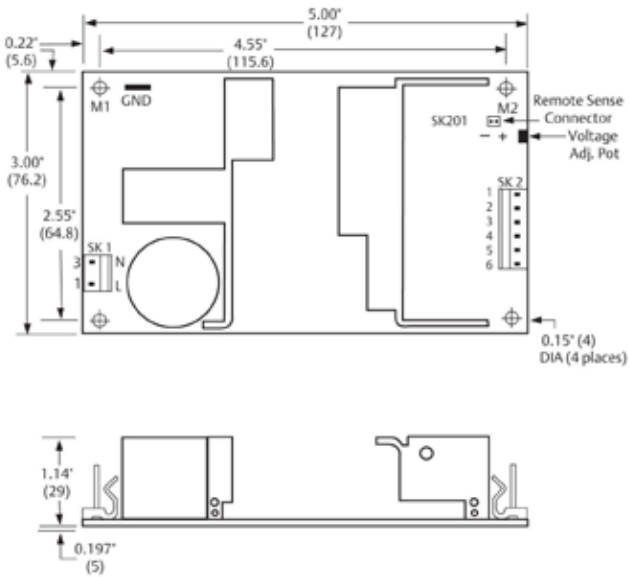

Case 1
(Weight: 0.5 lbs/0.23 kg approx.)



Case 2
(Weight: 0.45 lbs/0.20 kg approx.)

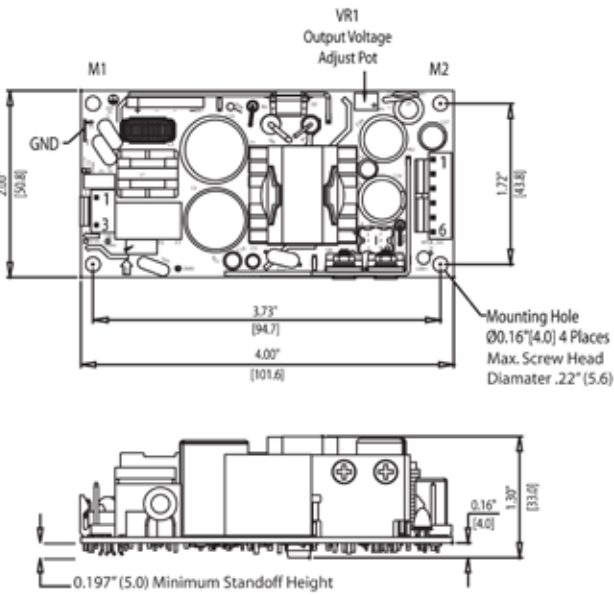

Case 3
(Weight: 0.41 lbs/0.18 kg approx.)



Case 4
(Weight: 0.75 lbs/0.34 kg approx.)

Notes:

1. Specifications subject to change without notice.
2. All dimensions in inches (mm), tolerance is $\pm 0.02"$ (± 0.5 mm)
3. Mounting holes M1 and M2 should be grounded for EMI purposes.
4. Mounting hole M1 is safety ground connection.
5. Specifications are for convection rating at factory settings at 115 Vac input, 25°C unless otherwise stated.

GL Series Dimensions (continued)

Bracket



Case 5
(Weight: 1.25 lbs/0.57 kg approx.)

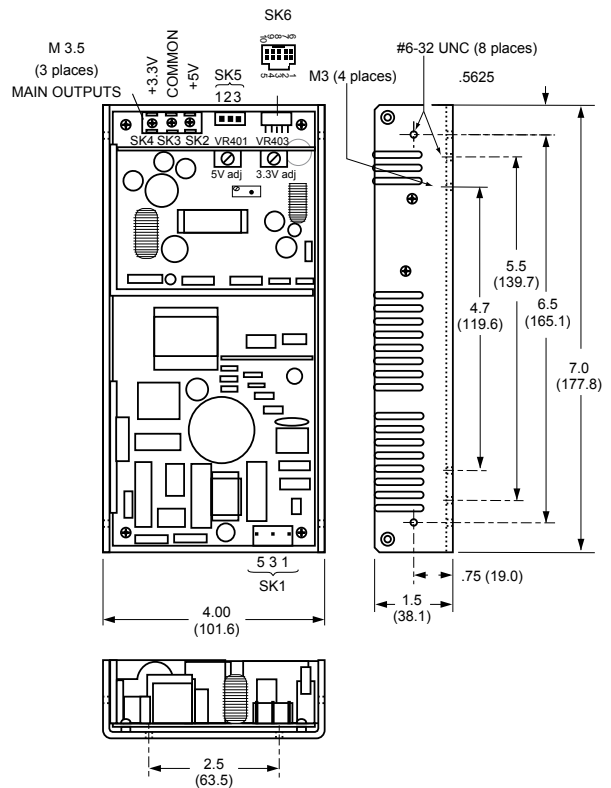

Case 6
(Weight: 1.38 lbs/0.63 kg approx.)
(See notes 7 & 8)

Notes:

1. Specifications subject to change without notice.
2. All dimensions in inches (mm), tolerance is ± 0.02 ".
3. Specifications are for convection rating at factory settings unless otherwise stated.
4. Mounting holes M1 and M2 should be grounded for EMI purposes.
5. Mounting hole M1 is safety ground connection.
6. L Bracket mounting (6-32) maximum insertion depth is .20" (5).
7. Remote inhibit requires an external 5 V @ 10 mA to activate.
8. Mounting maximum insertion depth is 0.12".

GL Series Dimensions (continued)



Case 7
(Weight: .71 lbs/0.32 kg approx.)

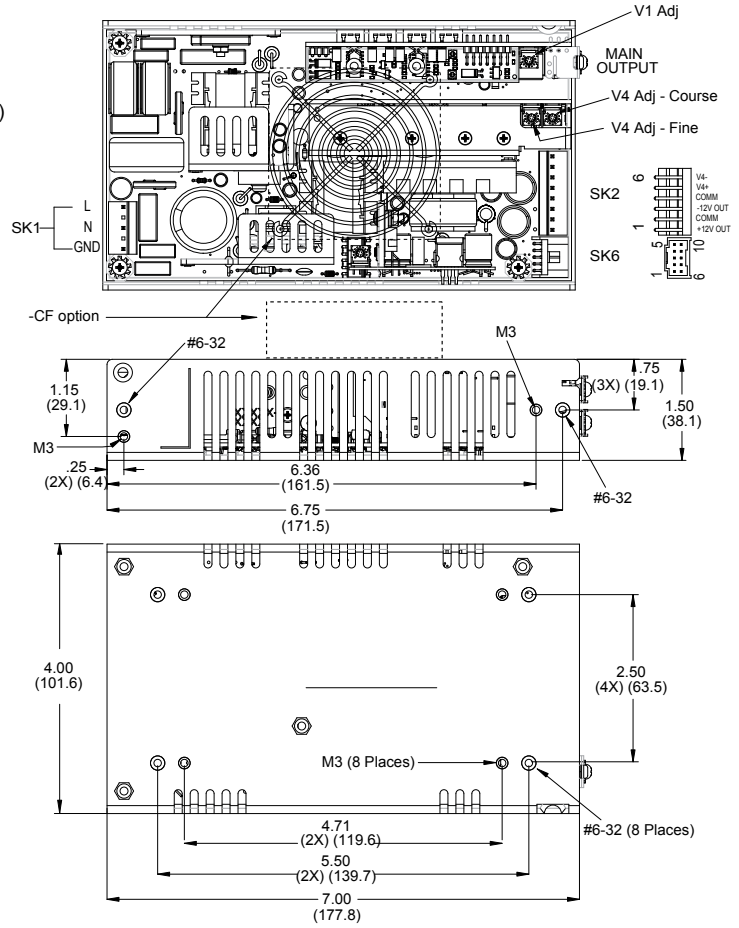

Case 8
(Weight: 1.63 lbs/0.74 kg approx.)
(See notes 6 & 7)

Notes:

1. Specifications subject to change without notice.
2. All dimensions in inches (mm), tolerance is ± 0.02 ".
3. Mounting holes MH1, MH2 and MH3 should be grounded for EMI purposes.
4. Mounting hole M1 is safety ground connection.
5. This power supply requires mounting on metal standoffs 0.20" (5 m) in height.
6. Specifications are for convection rating at factory settings at 115 Vac input 25°C unless otherwise stated.
7. Mounting screw maximum insertion depth is 0.12".

GL Series Dimensions (continued)

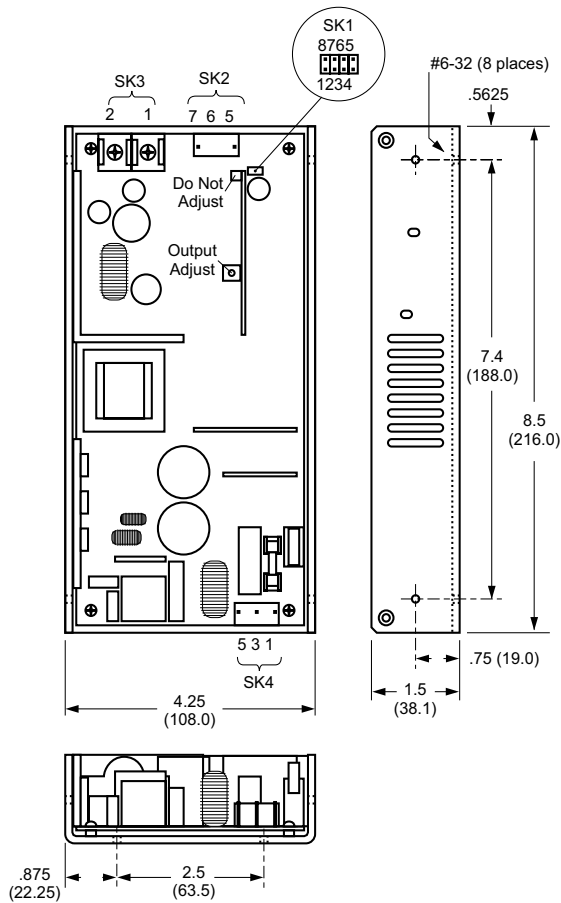

Case 9
(Weight: 1.75 lbs/0.80 kg approx.)

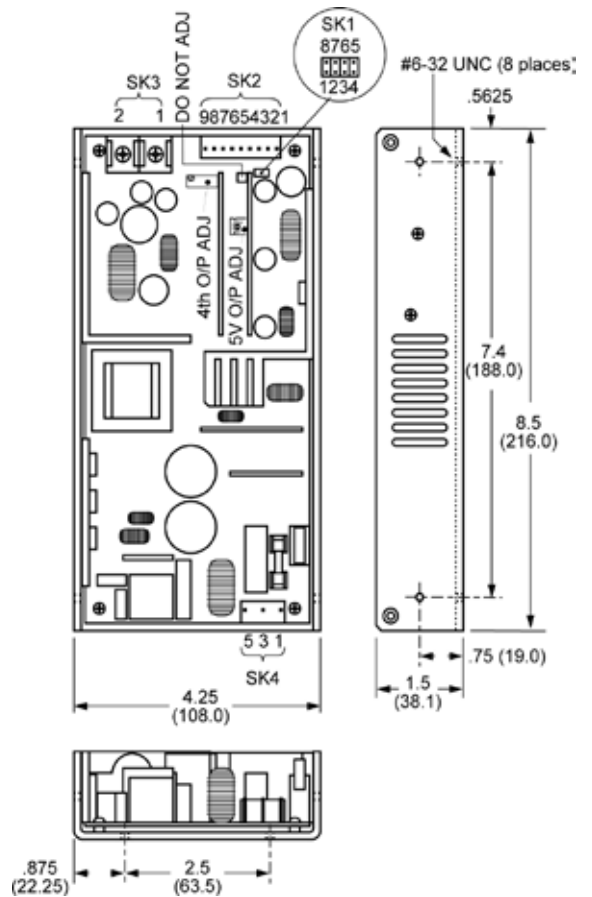

Case 10
(Weight: 1.75 lbs/0.80 kg approx.)

Notes:

1. Specifications subject to change without notice.
2. All dimensions in inches (mm), tolerance is ± 0.02 ".
3. Specifications are for convection rating at factory settings unless otherwise stated.
4. Remote inhibit requires an external 5 V @ 10 mA to activate.
5. Mounting (6-32) maximum insertion depth is 0.12".

GL Series Dimensions (continued)



Case 11
(Weight: 0.5 lb/0.23 kg approx.)

Case 12
(Weight: 2 lbs/0.91 kg approx.)
(See notes 1-4)

Notes:

1. Specifications subject to change without notice.
2. All dimensions in inches (mm), tolerance is ±0.02".
3. Specifications are for convection rating at factory settings at 115 Vac input, 25°C unless otherwise stated.
4. Mounting screw maximum insertion depth is 0.12".
5. Mounting holes M1 and M2 should be grounded for EMI purposes.
6. Mounting hole M1 is safety ground connection.

GL Series Dimensions (continued)

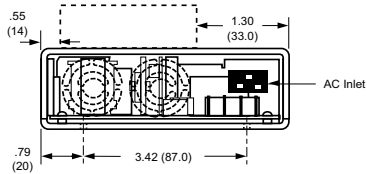
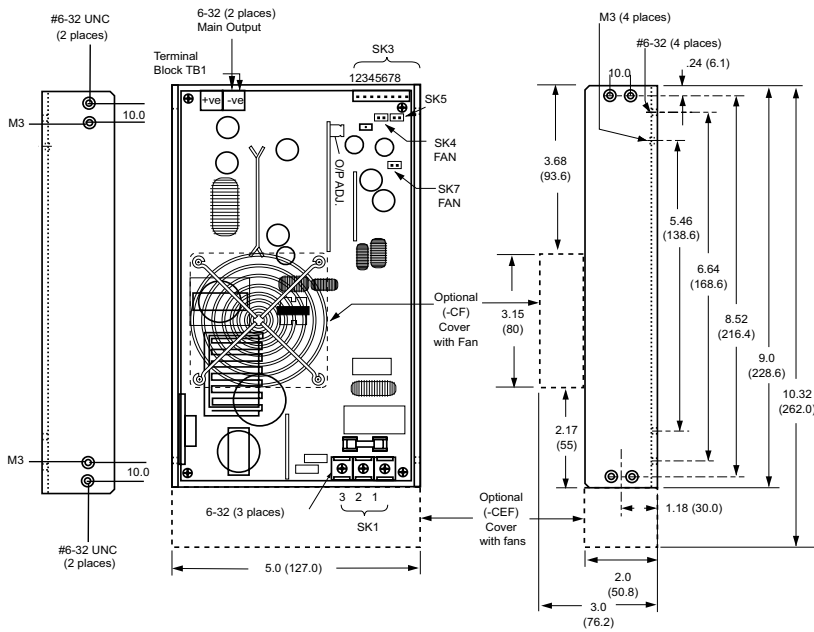

Case 13
(Weight: 2.6 lbs/1.19 kg approx.)

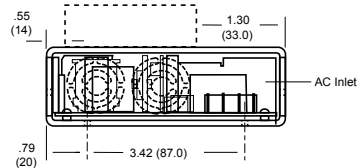

Case 14
(Weight: 3.1 lbs/1.41 kg approx.)

Notes:

1. Specifications subject to change without notice.
2. All dimensions in inches (mm), tolerance is ± 0.02 ".
3. Specifications are at factory settings.
4. To enable normally closed remote inhibit, cut jumper J1.
5. Mounting maximum insertion depth is 0.12".

GL Series Dimensions (continued)



Case 15
(Weight: 3.6 lbs/1.64 kg approx.)

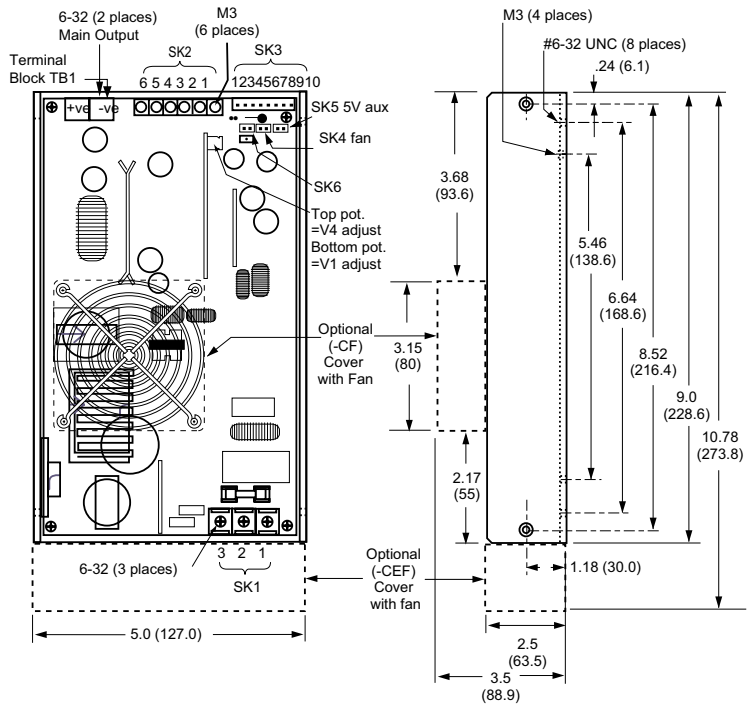

Case 16
(Weight: 4 lbs/1.8 kg approx.)

Notes:

1. Specifications subject to change without notice.
2. All dimensions in inches (mm), tolerance is ± 0.02 ".
3. Specifications are at factory settings.
4. To enable normally closed remote inhibit, cut jumper J1.
5. Mounting maximum insertion depth is 0.12".

GL Series Dimensions (continued)

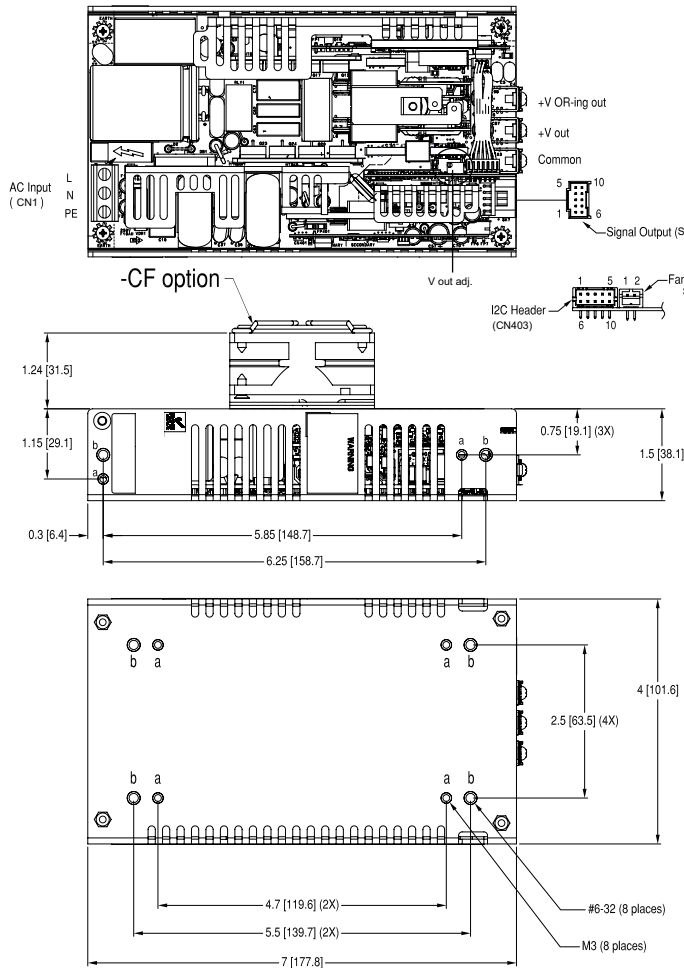

Case 17

(Weight: 3.016 lbs/1.18 kg approx.)

Notes:

1. Specifications subject to change without notice.
2. All dimensions in inches (mm), tolerance is ± 0.02 ".
3. Specifications are at factory settings.
4. Mounting maximum insertion depth is 0.12".

GL Series Pin Assignments

1A

Connector	GLS22	GLS23	GLS24	
SK1	PIN 1	Line		
	PIN 3	Neutral		
SK2	PIN 1	+5 V	+12 V	+15 V
	PIN 2	+5 V	+12 V	+15 V
	PIN 3	+5 V	+12 V	+15 V
	PIN 4	Common		
	PIN 5	Common		
	PIN 6	Common		
SK201	PIN 1	+Sense		
	PIN 2	-Sense		

GL Series Pin Assignments (continued)

2A

Connector	GLT22	GLT23	GLT24	GLT25	
SK1	PIN 1	Line			
	PIN 3	Neutral			
SK2	PIN 1	+12 V	+12 V	+12 V	+15 V
	PIN 2	+5 V	+5 V	+5 V	+5 V
	PIN 3	+5 V	+5 V	+5 V	+5 V
	PIN 4	Common			
	PIN 5	Common			
	PIN 6	-12 V	-12 V	-5 V	-15 V
SK201	PIN 1	+Sense			
	PIN 2	-Sense			

3A *

Connector	GLS42	GLS43	GLS44	GLS45	
SK1	PIN 1	Line			
	PIN 3	Neutral			
SK2	PIN 1	+5 V	+12 V	+15 V	+24 V
	PIN 2	+5 V	+12 V	+15 V	+24 V
	PIN 3	+5 V	+12 V	+15 V	+24 V
	PIN 4	Common			
	PIN 5	Common			
	PIN 6	Common			
SK201	PIN 1	+Sense			
	PIN 2	-Sense			

4A

Connector	GLT42 *	GLT43	GLT44	GLT45	GLT45 *
SK1	PIN 1	Line			
	PIN 3	Neutral			
SK2	PIN 1	+12 V		+15 V	+24 V
	PIN 2	+5 V			
	PIN 3	+5 V			
	PIN 4	Common			
	PIN 5	Common			
	PIN 6	-12 V	-5 V	-15 V	+12 V
SK201	PIN 1	+Sense			
	PIN 2	-Sense			

5A *

Connector	GLT52	GLT53	GLT54	
SK1	PIN 1	Neutral		
	PIN 3	Line		
SK2	PIN 1	+5 V		
	PIN 2	+5 V		
	PIN 3	Common		
	PIN 4	Common		
	PIN 5	-12 V	-15 V	+12 V
	PIN 6	+12 V	+15 V	+24 V

* Same Pin Assignments are attributed to both the non-medical and medical models.

GL Series Pin Assignments (continued)

6A *

Connector	GLS52	GLS53	GLS54	GLS55	GLS58	
SK1	PIN 1	Line				
	PIN 3	Neutral				
SK2	PIN 1	+5 V	+12 V	+15 V	+24 V	+48 V
	PIN 2	+5 V	+12 V	+15 V	+24 V	+48 V
	PIN 3	Common				
	PIN 4	Common				
	PIN 5	-Sense				
	PIN 6	+Sense				

7A

Connector	GLS62	GLS63 (GLS62-M)	GLS64 (GLS63-M)	GLS65	
SK1	PIN 1	Neutral			
	PIN 3	Line			
SK2	PIN 1	5 V	+12 V	+15 V	+24 V
	PIN 2	5 V	+12 V	+15 V	+24 V
	PIN 3	5 V	+12 V	+15 V	+24 V
	PIN 4	Common			
	PIN 5	Common			
	PIN 6	Common			
SK201	PIN 1	+Sense			
	PIN 2	-Sense			

8A

Connector	GLT62	GLT63	GLT64	GLT65	
SK1	PIN 1	Neutral			
	PIN 3	Line			
SK2	PIN 1	+12 V	+15 V	+12 V	+24 V
	PIN 2	+5 V	+5 V	+5 V	+5 V
	PIN 3	+5 V	+5 V	+5 V	+5 V
	PIN 4	Common			
	PIN 5	Common			
	PIN 6	-12 V	-15 V	-5 V	+12 V
SK201	PIN 1	+Sense			
	PIN 2	-Sense			

9A

Connector	GLS114	GLS115	
SK1	PIN 1	Ground	
	PIN 3	Neutral	
	PIN 5	Line	
SK2	PIN 1	+15 V	+24 V
	PIN 2	+15 V	+24 V
	PIN 3	+15 V	+24 V
	PIN 4	Common	
	PIN 5	Common	
	PIN 6	Common	
	PIN 7	Common	
	PIN 8	+15 V	+24 V
	PIN 9	+15 V	+24 V
SK201	PIN 1	+Sense	
	PIN 2	-Sense	
SK202	PIN 1	Power OK	
	PIN 2	Ground	

10A

Connector	GLQ112	GLQ113	GLQ114	
SK1	PIN 1	Ground		
	PIN 3	Neutral		
	PIN 5	Line		
SK2	PIN 1	+5 V		
	PIN 2	+5 V		
	PIN 3	+5 V		
	PIN 4	Common		
	PIN 5	Common		
	PIN 6	Common		
	PIN 7	Common		
	PIN 8	+12 V	+15 V	+12 V
	PIN 9	+12 V	+15 V	+12 V
	PIN 10	-12 V	-15 V	-12 V
	PIN 11	+5-25 V	+5-25 V	+24 V
	PIN 12	-5-25 V	-5-25 V	Common
SK201	PIN 1	+Sense		
	PIN 2	-Sense		
SK202	PIN 1	Power OK		
	PIN 2	Ground		

11A

Connector	GLQ123	
SK1	PIN 1	Ground
	PIN 3	Neutral
	PIN 5	Line
SK5	PIN 1	+12 V
	PIN 2	Common
	PIN 3	-12 V
SK6	PIN 1	3.3 V Single Wire Parallel
	PIN 2	-3.3 V Sense
	PIN 3	+3.3 V +Sense
	PIN 4	5 V Single Wire Parallel
	PIN 5	Common
	PIN 6	+5 V Sense
	PIN 7	-5 V Sense
	PIN 8	+ Inhibit
	PIN 9	- Inhibit
	PIN 10	Power Fail

12A

Connector	GLS120	
SK1	PIN 1	Neutral
	PIN 3	Line
SK2	TB-1	Common
	TB-2	Main Output
SK3	PIN 1	+V1 Remote Sense
	PIN 2	-V1 Remote Sense
	PIN 3	+Remote Inhibit
	PIN 4	-Remote Inhibit
	PIN 5	+Power Fail
	PIN 6	Common
	PIN 7	Single Wire Parallel
	PIN 8	+12 V
	PIN 9	12 V Common
	PIN 10	+5 V Standby

* Same Pin Assignments are attributed to both the non-medical and medical models.

GL Series Pin Assignments (continued)

13A

Connector	GLQ142	
SK1	PIN 1	Ground
	PIN 3	Neutral
	PIN 5	Line
SK2	PIN 1	+12 V
	PIN 2	Common
	PIN 3	-12 V
	PIN 4	Common
	PIN 5	+5 V to +25 V (Float)
	PIN 6	Common (Float)
	PIN 7	Common (Float)
SK4	TB-1	Common
	TB-2	+5 V
SK3	PIN 1	No Connection
	PIN 2	DC Power Good
	PIN 3	No Connection
	PIN 4	V1 Single Wire Parallel
	PIN 5	Common
	PIN 6	+V1 Sense
	PIN 7	Sense Common
	PIN 8	+Inhibit
	PIN 9	-Inhibit
	PIN 10	Power Fail

14A

Connector	GLS152	GLS153	GLS155
SK1	PIN 1	Inhibit -ve	
	PIN 2	Inhibit +ve	
	PIN 3	VCC	
	PIN 4	No Connection	
	PIN 5	Common	
	PIN 6	-Sense	
	PIN 7	+Sense	
	PIN 8	Current Share	
SK2	PIN 5	Common	
	PIN 6	Pin Removed	
	PIN 7	Power OK	
SK3	TB-1	Common	
	TB-2	+5 V	+12 V to +15 V
SK4	PIN 1	Ground	
	PIN 3	Line	
	PIN 5	Neutral	

15A

Connector	GLQ152	GLQ153	GLQ154	
SK1	PIN 1	Inhibit -ve		
	PIN 2	Inhibit +ve		
	PIN 3	+12 V	+15 V	+12V
	PIN 4	No Connection		
	PIN 5	Common		
	PIN 6	-Sense		
	PIN 7	+Sense		
	PIN 8	I Share		
SK2	PIN 1,2	+12 V	+15 V	+12 V
	PIN 3,4,5	Common	Common	Common
	PIN 6	-12 V	-15 V	-12 V
	PIN 7	Power OK		
	PIN 8	+5 V to +25 V (Float)		+24 V
	PIN 9	Common (Float)		Common
SK3	TB-1	Common		
	TB-2	+5 V		
SK4	PIN 1	Ground		
	PIN 3	Line		
	PIN 5	Neutral		

16A *

Connector	GLS17x	
SK1	PIN 1	+12 V
	PIN 2	5 V Standby
	PIN 3	Common
	PIN 4	V1 Single Wire Parallel
	PIN 5	Common
	PIN 6	+V1 Sense
	PIN 7	Sense Common
	PIN 8	Remote Inhibit
	PIN 9	DC Power Good
	PIN 10	Power OK
SK2	TB-1	Common
	TB-2	Main Output
SK3	PIN 1	Ground
	PIN 2	Line
	PIN 5	Neutral

* Same Pin Assignments are attributed to both the non-medical and medical models.

17A

Connector	GLQ172	GLQ173	
SK1	PIN 1	No Connection	V4 Single Wire Parallel
	PIN 2	5 V Standby	
	PIN 3	No Connection	+V4 Sense
	PIN 4	V1 Single Wire Parallel	
	PIN 5	Common	
	PIN 6	+V1 Sense	
	PIN 7	Sense Common	
	PIN 8	Remote Inhibit	
	PIN 9	DC Power Good	
	PIN 10	Power OK	
SK2	PIN 1,2	+12 V	
	PIN 3,4,5	Common	
	PIN 6	-12 V	
	PIN 7	Power OK	
	PIN 8	+3.3 V to +25 V (Float)	No Connection
SK3	PIN 9	Common (Float)	No Connection
	TB-1,3	Common	
	TB-2	+5 V (3.3 V to 5.5 V)	
SK4	TB-4	No Connection	+5 V (3.3 V to 5.5 V)
	PIN 1	Ground	
	PIN 3	Line	
SK5	PIN 5	Neutral	

18A

Connector	GLS250	
SK1	PIN 1	Neutral
	PIN 2	Line
	PIN 3	Ground
SK3	PIN 1	+Remote Sense
	PIN 2	-Remote Sense
	PIN 3	Remote Inhibit (N.O)
	PIN 4	Remote Inhibit (N.C)
	PIN 5	Common
	PIN 6	Current Share
	PIN 7	Power Fail
	PIN 8	DC Power Good
SK4	PIN 1	+Fan's power source (12 V @ 500 mA)
	PIN 2	-Fan's power source (12 V @ 500 mA)
SK5	PIN 1	+Supervisory output supply (5 V @ 100 mA)
	PIN 2	-Supervisory output supply (5 V @ 100 mA)
SK7	PIN 1	+Fan's power source (12 V @ 500 mA)
	PIN 2	+Fan's power source (12 V @ 500 mA)

GL Series Pin Assignments (continued)

19A

Connector	GLQ250	
SK1	PIN 1	Neutral
	PIN 2	Line
	PIN 3	Ground
SK2	PIN 1	+12 / 15 V
	PIN 2	Common
	PIN 3	Common
	PIN 4	-12 / 15 V
	PIN 5	5-25 V RET Float
	PIN 6	5-25 V Float
SK3	PIN 1	+Remote Sense
	PIN 2	-Remote Sense
	PIN 3	Remote Inhibit (N.O.)
	PIN 4	Remote Inhibit (N.C.)
	PIN 5	Common
	PIN 6	Current Share
	PIN 7	Power Fail
	PIN 8	DC Power Good
SK4	PIN 1	+Fan's power source (12 V @ 500 mA)
	PIN 2	+Fan's power source (12 V @ 500 mA)
SK5	PIN 1	+Supervisory output supply (5 V @ 100 mA)
	PIN 2	-Supervisory output supply (5 V @ 100 mA)
SK7	PIN 1	+Fan's power source (12 V @ 500 mA)
	PIN 2	+Fan's power source (12 V @ 500 mA)

22A *

Connector	GL500	
CN1	PIN 1	Line
	PIN 3	Neutral
	PIN 5	Ground
SK7	PIN 1	V1 Single Wire Parallel
	PIN 2	-Remote Sense
	PIN 3	+Remote Sense
	PIN 4	5 VSB (Standby)
	PIN 5	5 VSB Return
	PIN 6	+12 V
	PIN 7	Common
	PIN 8	Inhibit
	PIN 9	DC Power Good
	PIN 10	Power Fail (POK)
CN403	PIN 1	5 V_I ² C
	PIN 2	Ground
	PIN 3	A2
	PIN 4	A0
	PIN 5	SVCC2_OR
	PIN 6	I ² C_SDA
	PIN 7	I ² C_SLC
	PIN 8	A1
	PIN 9	No Connection
	PIN 10	+12V_RTN_CTRL
Adjustment Potentiometers		
P1	+V1 Output Adjust	

20A

Connector	GLS350	
SK1	PIN 1	Neutral
	PIN 2	Line
	PIN 3	Ground
SK3	PIN 1	No Connection
	PIN 2	No Connection
	PIN 3	+Sense
	PIN 4	-Sense
	PIN 5	Power OK
	PIN 6	Current Share
	PIN 7	DC Power Good
	PIN 8	Inhibit (N.O.)
	PIN 9	Inhibit (N.C.)
	PIN 10	Common
SK4	PIN 1	+5 V aux (5 V @ 100 mA)
	PIN 2	-Common
SK5	PIN 1	+Fan 1 (12 V @ 150 mA)
	PIN 2	-Common
SK6	PIN 1	+Fan 2 (12 V @ 150 mA)
	PIN 2	-Common

21A

Connector	GLQ350	
SK1	PIN 1	Neutral
	PIN 2	Line
	PIN 3	Ground
SK2	PIN 1	+12 / 15 V
	PIN 2	Common
	PIN 3	Common
	PIN 4	-12 / 15 V
	PIN 5	3.3-25 V RET Float
	PIN 6	3.3-25 V Float
SK3	PIN 1	+Sense V4
	PIN 2	-Sense V4
	PIN 3	+Sense V1
	PIN 4	-Sense V1
	PIN 5	Power OK
	PIN 6	Current Share
	PIN 7	DC Power Good
	PIN 8	Inhibit (N.O.)
	PIN 9	Inhibit (N.C.)
	PIN 10	Common
SK4	PIN 1	+Fan 1 (12 V @ 150 mA)
	PIN 2	-Common
SK5	PIN 1	+5 V aux (5 V @ 100 mA)
	PIN 2	-Common
SK6	PIN 1	+Fan 2 (12 V @ 150 mA)
	PIN 2	-Common

* Same Pin Assignments are attributed to both the non-medical and medical models.

GL Series Mating Connectors

1B *

Connector Kit #70-841-006 includes the following:	
AC Input:	Molex 09-50-8031 (USA) Not required for (-T) option 09-91-0300 (UK) PINS: 08-52-0113 (-0111 for medical)
DC Outputs:	Molex 09-50-8061 (USA) Not required for (-T) option 09-91-0600 (UK) PINS: 08-52-0113 (-0111 for medical)
Remote Sense:	Molex 22-01-2025 PINS: 08-52-0123 (-0114 for medical)

2B *

Connector Kit #70-841-006 includes the following:	
AC Input:	Molex 09-50-8031 (USA) 09-91-0300 (UK) PINS: 08-52-0113
DC Outputs:	Molex 09-50-8061 (USA) 09-91-0600 (UK) PINS: 08-52-0113

3B *

Connector Kit #70-841-006 includes the following:	
AC Input:	Molex 09-50-8031 (USA) Not required for (-T) option 09-91-0300 (UK) PINS: 08-58-0111 (-0113 for medical)
DC Outputs:	Molex 09-50-8061 (USA) Not required for (-T) option 09-91-0600 (UK) PINS: 08-58-0113
Remote Sense:	Molex 22-01-2025 PINS: 08-52-0113

4B *

Connector Kit #70-841-006 includes the following:	
AC Input:	Molex 09-50-8031 (USA) 09-91-0300 (UK) PINS: 08-58-0111
DC Outputs:	Molex 09-50-8061 (USA) 09-91-0600 (UK) PINS: 08-52-0113
Remote Sense:	Molex 22-01-2025 PINS: 08-52-0113

5B

Connector Kit #70-841-007 includes the following:	
AC Input:	Molex 09-50-8051 (USA) 09-91-0500 (UK) PINS: 08-58-0111
DC Outputs:	Molex 09-50-8091 (USA) 09-91-0900 (UK) PINS: 08-58-0111
Remote Sense/ Power Fail:	Molex 22-01-1022 (USA) 22-01-1023 (UK) PINS: 08-50-0114

6B

Connector Kit #70-841-008 includes the following:	
AC Input:	Molex 09-50-8051 (USA) 09-91-0500 (UK) PINS: 08-58-0111
DC Outputs:	Molex 09-50-8121 (USA) 09-91-1200 (UK) PINS: 08-58-0111
Remote Sense/ Power Fail:	Molex 22-01-1022 (USA) 22-01-1023 (UK) PINS: 08-50-0114

7B

Connector Kit #70-841-012 includes the following:	
(SK1) AC Input:	Molex 09-50-8051 (USA) 09-91-0500 (UK) PINS: 08-58-0111
SK2,3,4:	Molex series 19141-0058/0063
(SK5) ±12V:	Molex: 09-50-8031 (USA) Molex: 09-91-0300 (UK) PINS: 08-58-0111
(SK6) Control Signals:	Molex: 90142-0010; PINS: 90119-2110 or AMP: 87977-3; PINS: 87309-8

8B

Connector Kit #70-841-020 includes the following:	
(SK1) AC Input:	Molex 09-50-8031 (connector) PINS: 08-52-0113
(SK2) DC Outputs:	Molex series 19141-0058/0063 Spade lug
(SK3) Control Signals:	Molex: 90142-0010 (USA) PINS: 90119-2110 or AMP: 87977-3 PINS: 87309-8

9B

Connector Kit #70-841-017 includes the following:	
(SK1) AC Input:	Molex 09-50-8051 (USA) 09-91-0500 (UK) PINS: 08-58-0111
(SK2) Aux DC Outputs:	Molex: 09-50-8061 (USA) Molex: 09-91-0600 (UK) PINS: 08-58-0111
(SK6) Control Signals:	Molex: 90142-0010 (USA) PINS: 90119-2110 or AMP: 87977-3 PINS: 87309-8
(SK4) Main Output:	Molex: BB-124-08

* Same Mating Connectors are attributed to both standard and medical models.

GL Series Mating Connectors (continued)

10B

Connector Kit #70-841-009 includes the following:	
(SK4) AC Input:	Molex: 09-50-8051 (USA) Molex:09-91-0500 (UK) PINS: 08-58-0111
(SK2) Power Fail:	Molex: 09-50-8031 (USA) Molex: 09-91-0300 (UK) PINS: 08-58-0111
(SK1) Remote Sense/ Remote Inhibit:	Molex 51110-0851 (USA) PINS: 50394-8100

11B

Connector Kit #70-841-010 includes the following:	
(SK4) AC Input:	Molex: 09-50-8051 (USA) Molex:09-91-0500 (UK) PINS: 08-58-0111
(SK2) Aux DC Outputs/ Power Fail:	Molex: 09-50-8091 (USA) Molex: 09-91-0900 (UK) PINS: 08-58-0111
(SK1) Remote Sense/ Remote Inhibit:	Molex 51110-0851 (USA) PINS: 503-94-8100

12B *

Connector Kit #70-841-016 includes the following:	
(SK4) AC Input:	Molex: 09-50-8051 (USA) Molex:09-91-0500 (UK) PINS: 08-58-0111
(SK3) DC Outputs:	Molex: 19141-0058
(SK1) Remote Sense/ Remote Inhibit:	Molex 90142-0010 (USA) PINS: 90119-2110 Amp: 87977-3 PINS: 87309-8

13B

Connector Kit #70-841-015 includes the following:	
(SK4) AC Input:	Molex 09-50-8051 (USA) Molex:09-91-0500 (UK) PINS: 08-58-0111
(SK3) Main Output:	Molex series 19141-0058/0063
(SK2) Aux DC Outputs/ Power Fail:	Molex 09-50-8091 (USA) Molex:09-91-0900 (UK) PINS: 08-58-0111
(SK1) Control Signals:	Molex: 90142-0010 (USA) PINS: 90119-2110 or AMP: 87977-3 PINS: 87309-8

14B

Connector Kit #70-841-005 includes the following:	
SK3	Molex 22-01-1084; PINS: 08-70-0057
SK4	Molex 22-01-3027; PINS: 08-50-0114
SK5	Molex 22-01-3027; PINS:08-50-0114
SK7	Molex: 22-01-3027 PINS: 08-50-0114

15B

Connector Kit #70-841-011 includes the following:	
SK3	Molex 22-01-1104; PINS: 08-70-0057
SK4	Molex 22-01-3027; PINS: 08-50-0114
SK5	Molex 22-01-3027; PINS:08-50-0114
SK6	Molex: 22-01-3027; PINS: 08-50-0114

16B

Connector Kit #70-841-011 includes the following:	
SK3	Molex 22-01-1084; PINS: 08-70-0057
SK4	Molex 22-01-3027; PINS: 08-50-0114
SK5	Molex 22-01-3027; PINS:08-50-0114
SK6	Molex: 22-01-3027; PINS: 08-50-0114

17B

Connector Kit #70-841-024 includes the following:	
SK4,5,6	Molex 19141-0058
SK7 Control Signals	Molex 90142-0010; PINS: 90119-2110 or AMP: 87977-3; PINS: 87309-8
SK8	Molex 22-01-2025; PINS:08-52-0123
CN403	JST PHDR-10VS PINS: JST 5PHD-002T-PO.5-L/P or Landwin 2050 S1000; PINS: 2053T011P

* Same Mating Connectors are attributed to both standard and medical models.

GL Compact Series: Single Output Switchers

The GL Compact Series combines both medical and non-medical approvals into one unit. These models offer very high reliability, high efficiency, active Power Factor Correction and very low ground leakage current compact size

Each model of GL100-M and GL200-M series complies with the medical and ITE safety standards, enabling it to be used for both medical or non-medical standard applications.

Features:

- Medical Approvals
- Smaller Size
- Dual Rating
- High demonstrated MTBF
- Automatic overvoltage protection
- Overload protection
- Extensive safety approvals
- Two year limited warranty

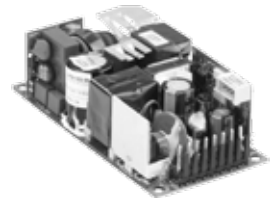

Specifications

	GL100-M Series	GL200-M Series
Input		
Input Voltage	90 - 264 Vac; 120 - 300 Vdc	
Frequency	47-63 Hz	
Inrush Current	50 A max., cold start @ 25°C	
Efficiency	88% typical at full load	
EMI/RFI	FCC Class B conducted; CISPR 22 Class B conducted; EN55022 Class B conducted; VDE0878PT3 Class B conducted	
Power Factor	0.99 typical	
Safety Ground Leakage Current	275 uA @ 50/60 Hz, 264 Vac input	
Output		
Power	100 W convection (80 W for GLS102-M)	125 W for convection; 200W
Adjustment Range on Main Output	±10% minimum on the main outputs	
Fan Output	12 V @ 1 A isolated, ±5%	
Hold-up Time	10 ms @ 150 W load, 120 Vac input	16 ms @ 250 W load, 120 Vac input
Overload	Short circuit protection on all outputs. Case overload protected @ 110-160% above rating	
Overvoltage Protection	15-35% above nominal output	
Logical Control		
Power Failure	Open collector logic signal goes high 100-500 msec after main output; it goes low at least 6 msec before loss of regulation	
Remote Sense	Compensates for 0.5 V lead drop minimum; Will operate without remote sense connected, Reverse connection	
General		
Temperature	Storage: -40°C to +85°C; Operating: 0° to 50°C ambient. Derate each output 2.5% per degree from 50° to 70°C, -20°C start up.	
Electromagnetic Susceptibility	Designed to meet EN61000-4; -2, -3, -4, -5, -6, -8, -11 Level 3	
Humidity	Operating; non-condensing 10% to 95% RH	
Vibration	IEC68-2-6 to the levels of IEC721-3-2	
MTBF	>550,000 hours demonstrated at full load, and 25°C ambient conditions	
Safety	IEC/EN/UL 60950-1, IEC/EN/UL 60601-1	

Selection Table

Medical and Non-Medical Series									
	Catalog Number	Description	Output 1	Output 2	Output 3	Output 4	Case*	Pin Assignments*	Mating Connectors*
GL100-M	GLS102-M	5 V 150W 2" X 4"	5 V @ 16 A [24 A]	-	-	-	1	1A	1B
	GLS103-M	12 V 150W 2" X 4"	12 V @ 8.3 A [12.5 A]	-	-	-			
	GLS104-M	15 V 150W 2" X 4"	15 V @ 6.7 A [10 A]	-	-	-			
	GLS105-M	24 V 150W 2" X 4"	24 V @ 4.2 A [6.3 A]	-	-	-			
	GLS108-M	48 V 150W 2" X 4"	48 V @ 2.1 A [3.1 A]	-	-	-			
GL200-M	GLS202-M	5 V 250W 3" X 5"	5 V @ 20 A [40 A]	-	-	-	2	2A	2B
	GLS203-M	12 V 250W 3" X 5"	12 V @ 10.3 A [20.8 A]	-	-	-			
	GLS204-M	15 V 250W 3" X 5"	15 V @ 8.3 A [16.6 A]	-	-	-			
	GLS205-M	24 V 250W 3" X 5"	24 V @ 5.2 A [10.4 A]	-	-	-			
	GLS208-M	48 V 250W 3" X 5"	48 V @ 2.6 A [5.2 A]	-	-	-			

* Refer to GL Series Dimensions and the sections that follow

GL Compact Series Dimensions

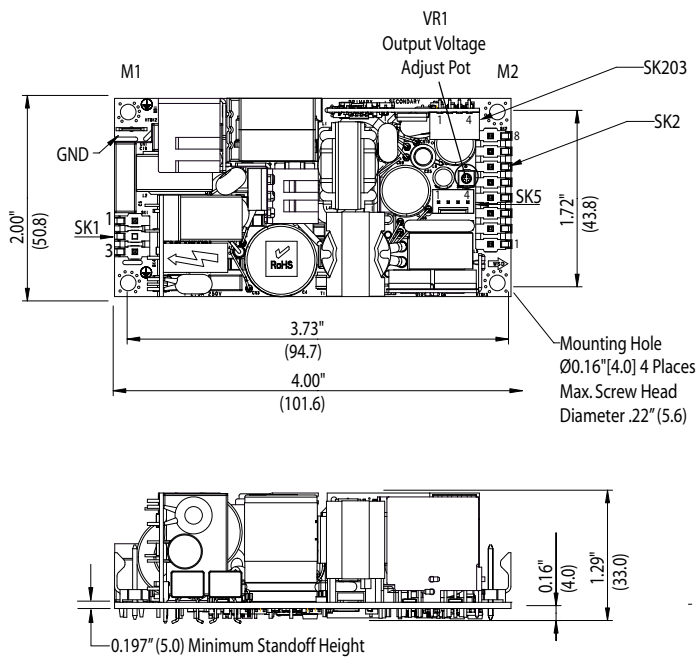

Case 1
(Weight: 0.44 lb/0.20 kg approx.)

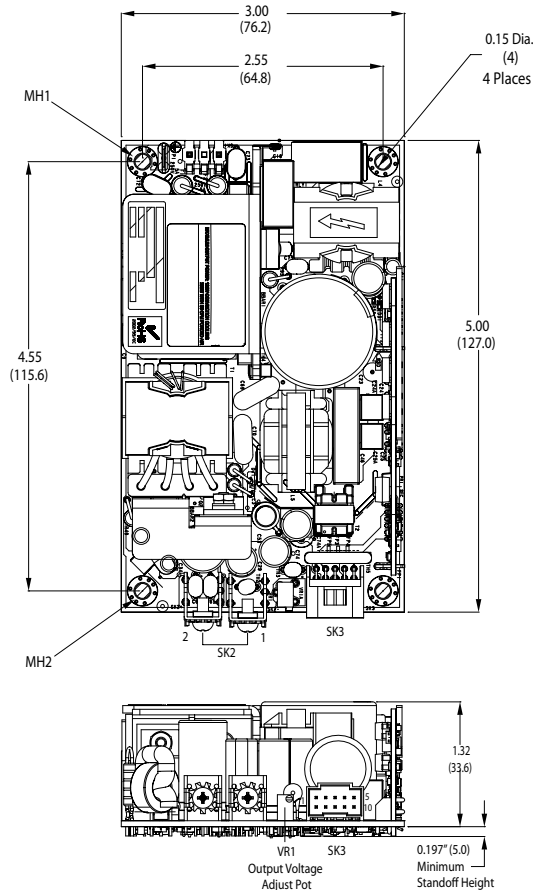

Case 2
(Weight: 0.75 lb/0.34 kg approx.)

Notes:

1. Specifications subject to change without notice.
2. All dimensions in inches (mm), tolerance is ± 0.02 ".
3. Mounting holes MH1, MH2, MH3 should be grounded for EMI purposes.
4. Mounting MH1 is safety ground connection.
5. Specifications are for convection rating at factory settings at 115 Vac input 25°C unless otherwise stated.
6. This power supply requires mounting on metal standoffs 0.20" (5 m) in height.

GL Compact Series Pin Assignments

1A

Connector		GLS102M	GLS103M	GLS104M	GLS105M	GLS108M
SK1	PIN 1	Neutral				
	PIN 3	Line				
SK2	PIN 1	Ground				
	PIN 2	Ground				
	PIN 3	Ground				
	PIN 4	Ground				
	PIN 5	+5	+12	+15	+24	+48
	PIN 6					
	PIN 7					
	PIN 8					
SK 203	PIN 1	Ground				
	PIN 2	Power Fail				
	PIN 3	-Remote Sense				
	PIN 4	+Remote Sense				
SK5	PIN 1	+12 V Fan				
	PIN 2	+12 V Fan				
	PIN 3	Fan Ground				
	PIN 4	Fan Ground				

2A

Connector		GLS202M	GLS203M	GLS204M	GLS205M	GLS208M
SK1	PIN 1	Neutral				
	PIN 3	Line				
SK2	TB-1	Common				
	TB-2	+5	+12	+15	+24	+48
SK3	PIN 1	+V1 Remote Sense				
	PIN 2	-V1 Remote Sense				
	PIN 3	No Connection				
	PIN 4	No Connection				
	PIN 5	+Power Fail				
	PIN 6	Common				
SK 203	PIN 7	No Connection				
	PIN 8	Common				
	PIN 9	+12 V Fan				
	PIN 10	+12 V Fan Ground				

GL Compact Series Mating Connectors

1B

Connector Kit #70-841-025 includes the following:

(SK1) AC Input:	Molex P/N 09-50-3031 or Landwin P/N: 3060S0302
(SK2) DC Outputs:	Molex P/N 09-50-3081 or Landwin P/N: 3060S0802
(SK203) Remote Sense:	Molex P/N 35155-0400 or Landwin P/N: 2640S04A0
(SK5) Fan:	Molex P/N 22-10-2047 or Landwin P/N: 2510S0400

2B

Connector Kit #70-841-018 includes the following:

(SK1) AC Input:	Molex 09-50-8031 (connector) PINS: 08-52-0113
(SK2) DC Outputs:	Molex 19141-0058/0063 Spade lug
(SK3) Control Signals:	Molex: 90142-0010 (USA) PINS: 90119-2110 or Amp: 87977-3 / PINS: 87309-8

Компания «Life Electronics» занимается поставками электронных компонентов импортного и отечественного производства от производителей и со складов крупных дистрибьюторов Европы, Америки и Азии.

С конца 2013 года компания активно расширяет линейку поставок компонентов по направлению коаксиальный кабель, кварцевые генераторы и конденсаторы (керамические, пленочные, электролитические), за счёт заключения дистрибьюторских договоров

Мы предлагаем:

- Конкурентоспособные цены и скидки постоянным клиентам.
- Специальные условия для постоянных клиентов.
- Подбор аналогов.
- Поставку компонентов в любых объемах, удовлетворяющих вашим потребностям.
- Приемлемые сроки поставки, возможна ускоренная поставка.
- Доставку товара в любую точку России и стран СНГ.
- Комплексную поставку.
- Работу по проектам и поставку образцов.
- Формирование склада под заказчика.
- Сертификаты соответствия на поставляемую продукцию (по желанию клиента).
- Тестирование поставляемой продукции.
- Поставку компонентов, требующих военную и космическую приемку.
- Входной контроль качества.
- Наличие сертификата ISO.

В составе нашей компании организован Конструкторский отдел, призванный помогать разработчикам, и инженерам.

Конструкторский отдел помогает осуществить:

- Регистрацию проекта у производителя компонентов.
- Техническую поддержку проекта.
- Защиту от снятия компонента с производства.
- Оценку стоимости проекта по компонентам.
- Изготовление тестовой платы монтаж и пусконаладочные работы.



Тел: +7 (812) 336 43 04 (многоканальный)
Email: org@lifeelectronics.ru