

# Evaluation Note for MCA1101/MCR1101

## $\pm 5A$ $\pm 20A$ $\pm 50A$ , 5V Isolated Current Sensors EVB EB0013 Rev A

©ACEINNA, Inc.

One Technology Drive, Suite 325, Andover, MA 01810, USA

Tel: +1-978-738-0900, Fax: +1-978-738-0196, [www.ACEINNA.com](http://www.ACEINNA.com)

Information furnished herein by ACEINNA is believed to be accurate and reliable. However, ACEINNA assumes no responsibility for its use, or for any infringements of patents or other rights of third parties resulting from its use. No license is granted by implication or otherwise under any patent or patent rights of ACEINNA. ACEINNA reserves the right to change this document without notification.

## DESCRIPTION

The EB0013 evaluation board provides a simple way to evaluate MCx1101 family of current sensor ICs. This double sided PCB with 4-ounce copper produces the low resistance path to the galvanically isolated primary current. An 8-pin connector P1 and test points enable users to easily access the signals of the secondary side bias and outputs. Two BNC outputs (VREF and VOUT) are intended to provide the low noise channels for VREF and VOUT signals to the oscilloscope or other test equipments.

## FEATURES

- **High Accuracy Current Sensor**
- **Superior Frequency Response (1.5 MHz 3dB BW)**
- **Fast output response time (300ns typical)**
- **Low Primary Resistance (0.9mΩ/50A and 1.3mΩ/5A/ 20A typical)**
- **5V Single Supply Operation**
- **Low power consumption (8mA typical)**
- **Overcurrent fault detection**
- **SOIC-16 package (RoHS/REACH compliant)**
- **-40°C to +105°C Operating Temperature Range**
- **UL/IEC/EN60950-1 Certified**
  - ✓ **4.8 kV Dielectric Strength Voltage**
  - ✓ **1097 VRMS Basic Isolation Voltage**
  - ✓ **400 VRMS Reinforced Isolation Voltage**

## ORDER INFORMATION

| EVB PART NUMBER  | Current Range              | Gain        | Voltage |
|------------------|----------------------------|-------------|---------|
| EVB MCA1101-5-5  | +/-5 Amp                   | Fixed       | 5V      |
| EVB MCA1101-20-5 | +/-20 Amp                  | Fixed       | 5V      |
| EVB MCA1101-50-5 | +/-50 Amp <sup>Note1</sup> | Fixed       | 5V      |
| EVB MCR1101-5-5  | +/-5 Amp                   | Ratiometric | 5V      |
| EVB MCR1101-20-5 | +/-20 Amp                  | Ratiometric | 5V      |
| EVB MCR1101-50-5 | +/-50 Amp <sup>Note1</sup> | Ratiometric | 5V      |

Note1: ±50A Pluse

## TEST BOARD PIN DESCRIPTION

| Name   | Connection                               | Description   |
|--------|--|---|
| I_IN   | Fix the wire of Primary Current by screw | Non-Inverting Current Sense Input   |
| I_OUT  | Fix the wire of Primary Current by screw | Inverting Current Sense Input   |
| VOC    | P1 Connector Pin 1                       | Input pin. Voltage on this pin defines the OCP threshold level.               |
| VCC    | P1 Connector Pin 2                       | Sensor power supply.  |
| VOUT   | P1 Connector Pin 3                       | Analog Output Signal linearly proportional to Primary Path Current            |
| VREF   | P1 Connector Pin 4                       | Zero Current Analog Reference Output  |
| GND    | P1 Connector Pin 5                       | Ground.   |
| TEST1  | P1 Connector Pin 6                       | For factory calibration only. Do not connect.                                 |
| TEST2  | P1 Connector Pin 7                       | For factory calibration only. Do not connect.                                 |
| FAULTB | P1 Connector Pin 8                       | Output pin, active low when the primary current exceeds the setting threshold |

## OPERATING INSTRUCTIONS

- Connect power supply to positive terminal and negative terminal to VCC and GND of P1, respectively
- Connect multimeter, oscilloscope, or other signal measurement devices to VOUT, VREF and GND through either P1 connector, test points, or BNC connectors
- Connect current to be measured to the I<sub>IN</sub> and I<sub>OUT</sub> Primary Wires. For correct positive/negative current readings, positive current should flow from I<sub>IN</sub> to I<sub>OUT</sub>.
- To read sensor output, VOUT, VREF, and VCC voltages must be measured and converted to a current per the electrical characteristics table.

### Note:

- This EVB is designed to work up to 50A peak (35A RMS) for thermal reasons. In order to evaluate the performance with 35 -50A DC, use pulsed current with appropriate duty cycle that guarantees no more than 35A RMS.
- High current will cause sensor IC and PCB to be very hot. The junction temperature can exceed 100°C. **Do not touch the chip and PCB.** The temperature rise can be reduced by using thicker cable and bigger screws.

## SCHEMATIC

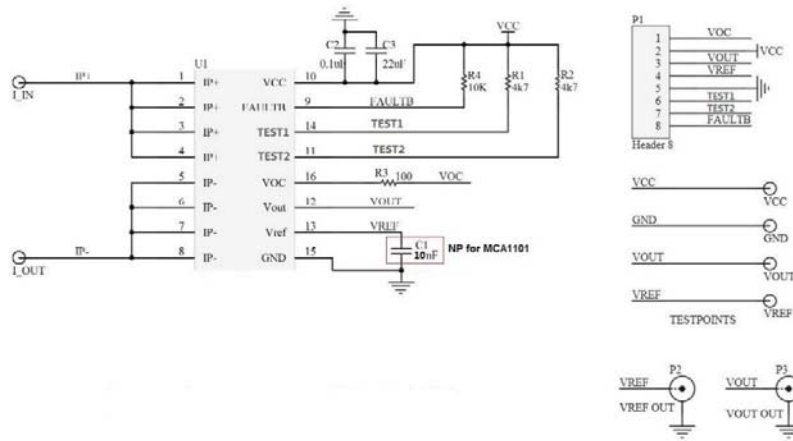

## PCB LAYOUT - TOP SIDE

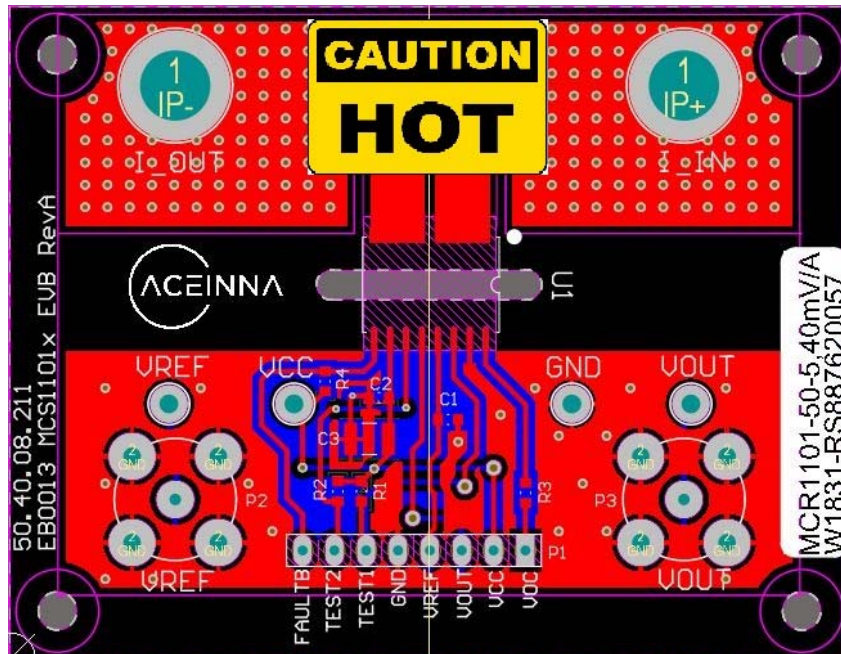

EB0013 REV A PHOTO

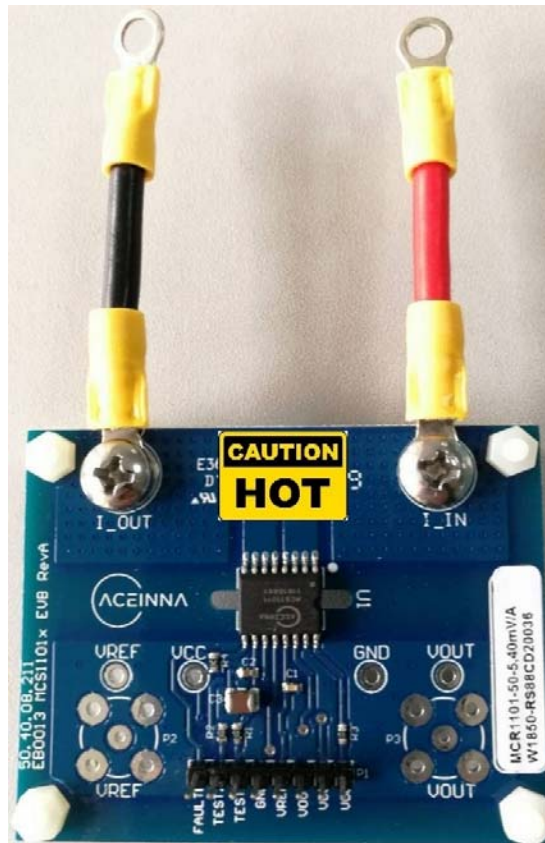

BILL OF MATERIALS

Reference Design

| Item  | Value         | Package          | Rating | Description                                      |
|-------|---------------|------------------|--------|--|
| R1,R2 | 4.7K $\Omega$ | 0603             | 1/10W  | Pull up resistor                                 |
| R3    | 100 $\Omega$  | 0603             | 1/10W  | Input limit resistor                             |
| R4    | 10K $\Omega$  | 0603             | 1/10W  | Pull up resistor                                 |
| C1    | 10nF          | X7R Ceramic/0603 | 10V    | Reference PIN coupling capacitor(NP for MCA1101) |
| C2    | 0.1uF         | X7R Ceramic/0603 | 10V    | VCC coupling capacitor                           |
| C3    | 22uF          | X7R Ceramic/1210 | 16V    | VCC coupling capacitor                           |
| U1    | MCx1101       | SOIC16           |        | AMR Current Sensor                               |

Компания «Life Electronics» занимается поставками электронных компонентов импортного и отечественного производства от производителей и со складов крупных дистрибьюторов Европы, Америки и Азии.

С конца 2013 года компания активно расширяет линейку поставок компонентов по направлению коаксиальный кабель, кварцевые генераторы и конденсаторы (керамические, пленочные, электролитические), за счёт заключения дистрибьюторских договоров

Мы предлагаем:

- Конкуренспособные цены и скидки постоянным клиентам.
- Специальные условия для постоянных клиентов.
- Подбор аналогов.
- Поставку компонентов в любых объемах, удовлетворяющих вашим потребностям.
- Приемлемые сроки поставки, возможна ускоренная поставка.
- Доставку товара в любую точку России и стран СНГ.
- Комплексную поставку.
- Работу по проектам и поставку образцов.
- Формирование склада под заказчика.
- Сертификаты соответствия на поставляемую продукцию (по желанию клиента).
- Тестирование поставляемой продукции.
- Поставку компонентов, требующих военную и космическую приемку.
- Входной контроль качества.
- Наличие сертификата ISO.

В составе нашей компании организован Конструкторский отдел, призванный помогать разработчикам, и инженерам.

Конструкторский отдел помогает осуществить:

- Регистрацию проекта у производителя компонентов.
- Техническую поддержку проекта.
- Защиту от снятия компонента с производства.
- Оценку стоимости проекта по компонентам.
- Изготовление тестовой платы монтаж и пусконаладочные работы.



Тел: +7 (812) 336 43 04 (многоканальный)  
Email: [org@lifeelectronics.ru](mailto:org@lifeelectronics.ru)