

PSR-SCP- 24UC/URM4/5X1/2X2 PSR-SPP- 24UC/URM4/5X1/2X2

Safety Relay as a Contact Extension Block



INTERFACE

Data Sheet
100011_en_03

© PHOENIX CONTACT - 02/2008

1 Description

The **PSR-...- 24UC/URM4/5X1/2X2** safety relay can be used as a contact extension block for contact multiplication according to DIN EN 60204-1/VDE 0113-1. It has positively driven contacts according to EN 50205, class A.

Depending on the basic device, up to safety category 4 according to EN 954-1 can be achieved once confirmation path 11-12 has been wired and correctly connected.

The relay has five enabling current paths, one signaling current path, and one confirmation path. The contacts drop out without delay according to stop category 0 (DIN EN 60204-1/VDE 0113-1).

The extension unit can be used as a contact multiplier for emergency stop, safety door, and optical data link monitoring relays as well as two-hand controls.

1.1 Features

- Contact extension block
- Safety category 4 according to EN 954-1 (depending on the basic device)
- Plug-in screw or spring-cage connection terminal blocks
- Single-channel or two-channel wiring
- Safe isolation
- Housing width of 35 mm
- Five enable contacts, one alarm contact, and one confirmation contact



WARNING: Risk of electric shock

Observe the safety instructions on page 4.



Make sure you always use the latest documentation.
It can be downloaded at www.download.phoenixcontact.com.
A conversion table is available on the Internet at
www.download.phoenixcontact.com/general/7000_en_00.pdf.



This data sheet is valid for all products listed on the following page:

2 Ordering Data

Safety Relays

Description	Type	Order No.	Pcs./Pck.
Safety relay as a contact extension block, with screw connection	PSR-SCP- 24UC/URM4/5X1/2X2	2963734	1
Safety relay as a contact extension block, with spring-cage connection	PSR-SPP- 24UC/URM4/5X1/2X2	2964005	1

Documentation

Description	Type	Order No.	Pcs./Pck.
Application manual for PSR safety relays	UM EN SAFETY RELAY APPLICATION	2888712	1

3 Technical Data

Input Data

Nominal input voltage U_N	24 V AC/DC
Permissible range	0.8 ... 1.1 x U_N
Typical current consumption at U_N	47 mA per channel
Typical response time (K1, K2)	20 ms
Typical release time (K1, K2)	20 ms
Surge protection	Suppressor diode
Status indicators (K1, K2)	Green LED

Output Data

Contact type: Positively driven contact assembly class A according to EN 50205	5 enabling current paths, 1 signaling current path, 1 confirmation path	
Contact material	Silver tin oxide, gold-flashed (AgSnO ₂ , 0.2 μm Au)	
Maximum switching voltage	250 V AC/DC	
Minimum switching voltage	15 V AC/DC	
Limiting continuous current		
N/O contact	6 A	
N/C contact (11-12)	3 A	
$I_{TH}^2 = I_1^2 + I_2^2 + \dots + I_N^2$	72 A ²	
Maximum inrush current		
N/O contact	6 A	
N/C contact (11-12)	3 A	
Minimum switching current	25 mA	
Maximum shutdown power ¹	Ohmic load $\tau = 0$ ms Inductive load $\tau = 40$ ms	
	24 V DC	144 W (72 W) ¹ 42 W
	48 V DC	288 W (144 W) ¹ 42 W
	110 V DC	110 W 42 W
	220 V DC	88 W 42 W
	250 V AC	1500 VA (750 VA) ¹
Minimum switching power	0.4 W	

Output Data (Continued)

Mechanical service life	10 ⁷ cycles, approximately			
Switching capacity according to DIN EN 60947-5-1/VDE 0660-200	Cycles		DC13	AC15
	3600/h:	24 V	2.5 A	–
		230 V	–	3 A
	360/h:	24 V DC/4 A		
230 V AC/4 A				
Short-circuit protection of the output circuits, external	6 A fast-blow or 4 A slow-blow			
¹ The maximum values given in brackets apply to N/C contacts 11-12.				

General Data

Permissible ambient operating temperature	-20°C ... +55°C
Nominal operating mode	100% operating factor
Degree of protection according to VDE 0470-1	
Housing	IP20
Connection terminal blocks	IP20
Installation location	IP54, minimum
Mounting position	Any
Air and creepage distances between the circuits	
Basic insulation ¹	According to DIN EN 50178:1998-04
Impulse voltage withstand level	4 kV ¹
Pollution degree	2
Surge voltage category	III
Dimensions (W x H x D)	
Screw connection	35 mm x 114.5 mm x 99 mm
Spring-cage connection	35 mm x 114.5 mm x 112 mm
Conductor cross-section	
Screw connection	0.2 mm ² ... 2.5 mm ²
Spring-cage connection	0.2 mm ² ... 1.5 mm ²
Stripping length	
Screw connection	7 mm
Spring-cage connection	8 mm
Housing material	Polyamide PA, not reinforced

¹ Safe isolation, reinforced insulation, and 6 kV between input circuit and output contact current paths (43-44, 53-54, 63-64, 71-72) and between the output contact current paths (43-44, 53-54, 63-64, 71-72) themselves.

Tests/Approvals

BG



UL/CUL



3.1 Block Diagram

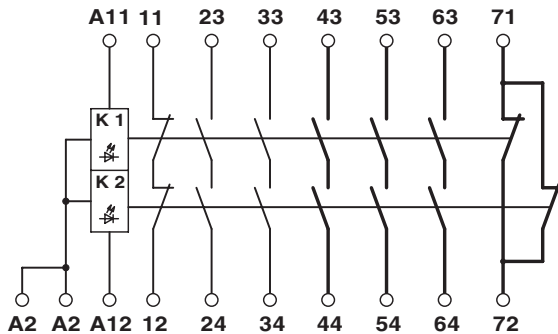

Figure 1 Block diagram

4 Safety Notes



WARNING: Risk of electric shock

During operation, parts of electrical switching devices carry hazardous voltages.

- Before working on the device, disconnect the power.
- Please observe the safety regulations of electrical engineering and industrial safety and liability associations. Disregarding these safety regulations may result in death, serious personal injury or damage to equipment.
- Startup, assembly, modifications, and upgrades may only be carried out by a skilled electrical engineer.



WARNING: Risk of automatic machine restart

- For emergency stop applications, the machine must be prevented from restarting automatically by a higher-level control system.
- Protective covers must not be removed when operating electrical switching devices.



WARNING: Danger due to faulty devices

The devices may be damaged following an error and correct operation can no longer be ensured.

- In the event of an error, replace the device immediately.
- Repairs to the device, especially if the housing must be opened, may only be carried out by the manufacturer or authorized persons. Otherwise the warranty is invalidated.



ATTENTION: Risk of damage to equipment due to incorrect installation

- For reliable operation, the safety relay must be installed in housing protected from dust and humidity (IP54).
- Carry out wiring according to the application.



ATTENTION: Risk of damage to equipment due to noise emission

When operating relay modules, the operator must meet the requirements for noise emission for electrical and electronic equipment (EN 61000-6-4) on the contact side and, if required, take appropriate measures.

5 Structure

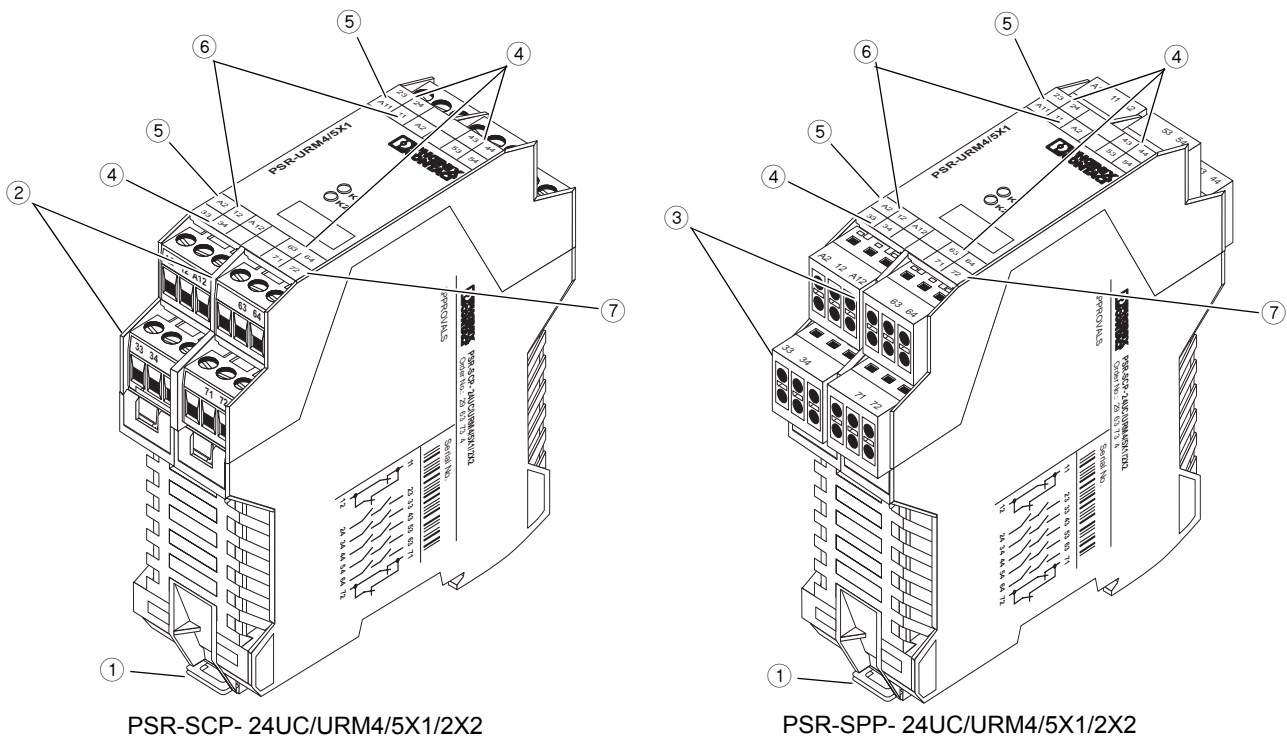

Figure 2 Structure

- 1 Metal lock for mounting on the DIN rail
- 2 COMBICON plug-in screw terminal blocks
- 3 COMBICON plug-in spring-cage terminal blocks
- 4 23-24, 33-34, 43-44, 53-54, and 63-64: Enabling current paths

- 5 A2, A11, A12: Input circuit
- 6 11, 12: Confirmation contact
- 7 71, 72: Alarm contact

6 Function

Input circuit A2-A11-A12 is installed in the enabling contact paths and confirmation path 11-12 is installed in the feedback circuit of the basic device.

When the 24 V AC/DC nominal input voltage is enabled at terminal blocks A11-A2 and A12-A2, the "K1" and "K2" LEDs light up. Contacts 23-24, 33-34, 43-44, 53-54, and 63-64 close, contacts 11-12 and 71-72 open.

If the basic device is triggered (e.g., by pressing an emergency stop button), the voltage in input circuit A2-A11-A12 is disconnected. N/O contacts 23-24, 33-34, 43-44, 53-54, and 63-64 open.

If all N/O contacts have been opened correctly, the N/C contacts are also closed and the feedback circuit is closed again.

For additional connection examples, see page 6.

7 Connection Notes



WARNING: Risk of electric shock

During operation, parts of electrical switching devices carry hazardous voltages.

- Before working on the device, disconnect the power.



ATTENTION: Risk of damage to equipment due to incorrect installation

- For reliable operation, the safety relay must be installed in housing protected from dust and humidity (IP54).
- Carry out wiring according to the application. Use the connection examples for this.

In order to comply with UL approval, use copper cables that are designed for operating temperatures > 75°C. For reliable and safe-to-touch contacts, strip the cable ends as follows:

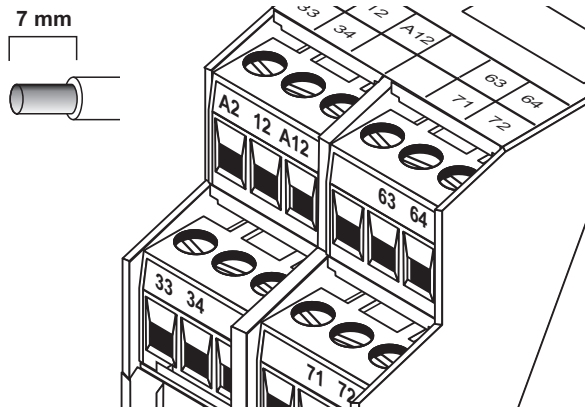

Figure 3 PSR-SCP- 24UC/URM4/5X1/2X2

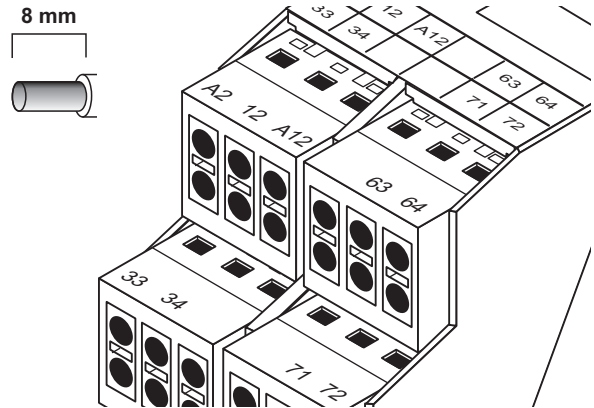
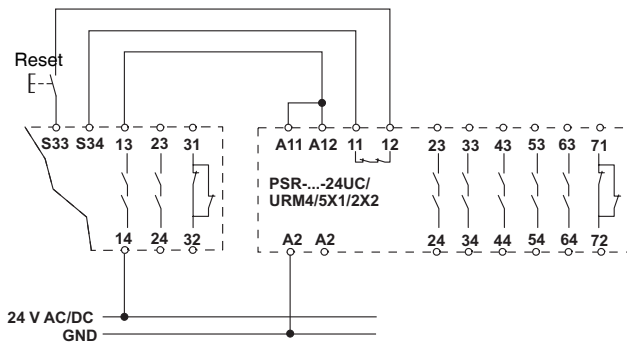
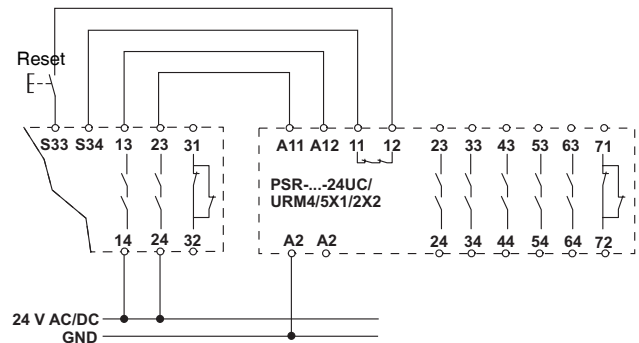

Figure 4 PSR-SPP- 24UC/URM4/5X1/2X2

8 Connection Examples



Single-channel connection with confirmation path 11-12 integrated in the basic device, suitable for up to safety category 4 (with error prevention)



Two-channel connection with confirmation path 11-12 integrated in the basic device, suitable for up to safety category 4

Компания «Life Electronics» занимается поставками электронных компонентов импортного и отечественного производства от производителей и со складов крупных дистрибьюторов Европы, Америки и Азии.

С конца 2013 года компания активно расширяет линейку поставок компонентов по направлению коаксиальный кабель, кварцевые генераторы и конденсаторы (керамические, пленочные, электролитические), за счёт заключения дистрибьюторских договоров

Мы предлагаем:

- Конкурентоспособные цены и скидки постоянным клиентам.
- Специальные условия для постоянных клиентов.
- Подбор аналогов.
- Поставку компонентов в любых объемах, удовлетворяющих вашим потребностям.
- Приемлемые сроки поставки, возможна ускоренная поставка.
- Доставку товара в любую точку России и стран СНГ.
- Комплексную поставку.
- Работу по проектам и поставку образцов.
- Формирование склада под заказчика.
- Сертификаты соответствия на поставляемую продукцию (по желанию клиента).
- Тестирование поставляемой продукции.
- Поставку компонентов, требующих военную и космическую приемку.
- Входной контроль качества.
- Наличие сертификата ISO.

В составе нашей компании организован Конструкторский отдел, призванный помогать разработчикам, и инженерам.

Конструкторский отдел помогает осуществить:

- Регистрацию проекта у производителя компонентов.
- Техническую поддержку проекта.
- Защиту от снятия компонента с производства.
- Оценку стоимости проекта по компонентам.
- Изготовление тестовой платы монтаж и пусконаладочные работы.



Тел: +7 (812) 336 43 04 (многоканальный)

Email: org@lifeelectronics.ru