

12-Channel, 2:1 Mux/DeMux Bus Switch

Features

- Near-Zero propagation delay
- 5-ohm switches connect inputs to outputs
- Direct bus connection when switches are ON
- Ultra Low Quiescent Power (0.2µA typical)
– Ideally suited for notebook applications
- Packaging (Pb-free & Green Available):
– 48-pin 150 mil wide plastic BQSOP (B)

Description

The PI5C33X257 is a 12-channel, 2:1 multiplexer/demultiplexer with three-state outputs. Inputs can be connected to outputs with low on resistance (5-ohm) with no additional ground bounce noise or propagation delay.

Pin Configuration

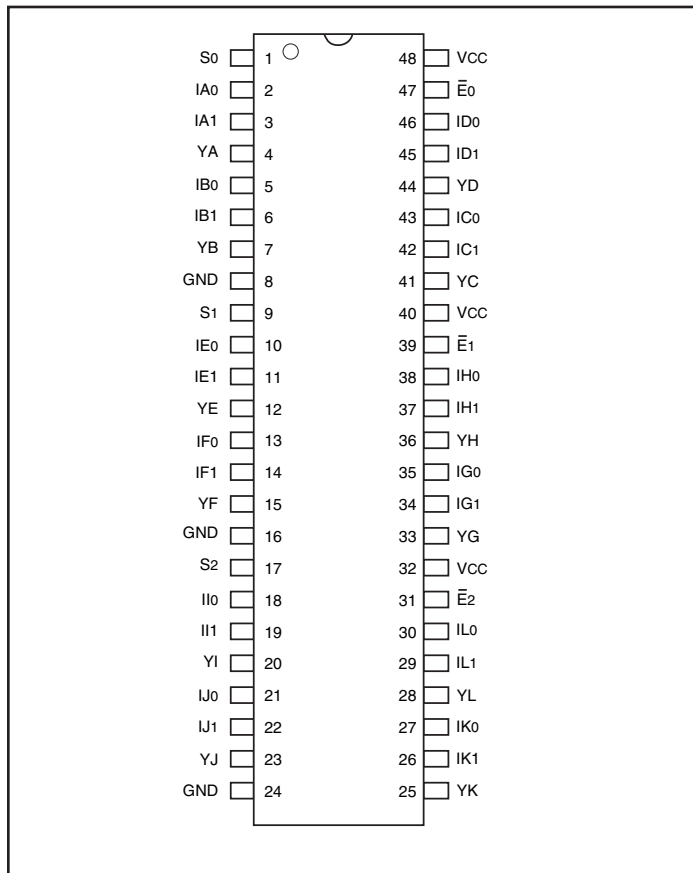

Truth Table⁽¹⁾

\bar{E}_n	S_n	YA ⁽²⁾	YB ⁽²⁾	YC ⁽²⁾	YD ⁽²⁾	Function
H	X	Hi-Z	Hi-Z	Hi-Z	Hi-Z	Disable
L	L	IA0	IB0	IC0	ID0	S = 0
L	H	IA1	IB1	IC1	ID1	S = 1

- Notes:**
1. H = High Voltage Level
L = Low Voltage Level
 2. n = 0 YA, YB, YC, YD
n = 1 YE, YF, YG, YH
n = 2 YI, YJ, YK, YL

Logic Block Diagram

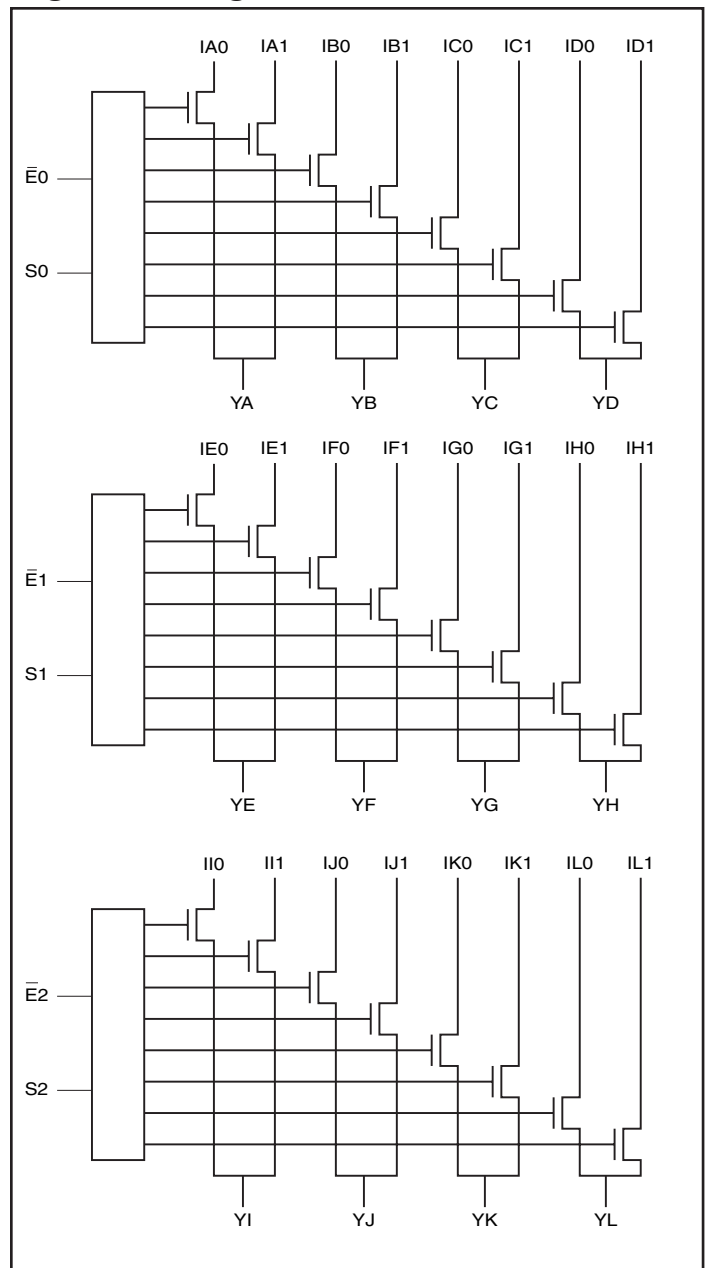

Product Pin Description

Pin Name	Description
IAn-ILn	Data Inputs
S	Select Inputs
En	Enable
YA-YL	Data Outputs
GND	Ground
Vcc	Power

Maximum Ratings

(Above which the useful life may be impaired. For user guidelines, not tested.)

Storage Temperature	-65°C to +150°C
Ambient Temperature with Power Applied	-40°C to +85°C
Supply Voltage to Ground Potential (Inputs & Vcc Only)	-0.5V to +7.0V
Supply Voltage to Ground Potential (Outputs & D/O Only) ..	-0.5V to +7.0V
DC Input Voltage	-0.5V to +7.0V
DC Output Current.....	120 mA
Power Dissipation	0.5W

Note:

Stresses greater than those listed under MAXIMUM RATINGS may cause permanent damage to the device. This is a stress rating only and functional operation of the device at these or any other conditions above those indicated in the operational sections of this specification is not implied. Exposure to absolute maximum rating conditions for extended periods may affect reliability.

DC Electrical Characteristics (Over the Operating Range, TA = -40°C to +85°C, VCC = 5V ±5%)

Parameters	Description	Test Conditions ⁽¹⁾	Min.	Typ ⁽²⁾	Max.	Units
V _{IH}	Input HIGH Voltage	Guaranteed Logic HIGH Level	2.0			V
V _{IL}	Input LOW Voltage	Guaranteed Logic LOW Level	-0.5		0.8	V
I _{IH}	Input HIGH Current	V _{CC} = Max., V _{IN} = V _{CC}			±1	mA
I _{IL}	Input LOW Current	V _{CC} = Max., V _{IN} = GND			±1	mA
I _{OZH}	High Impedance Output Current	0 ≤ I, Y ≤ V _{CC}			±1	mA
V _{IK}	Clamp Diode Voltage	V _{CC} = Min., I _{IN} = -18 mA		-0.7	-1.2	V
I _{OS}	Short Circuit Current ⁽³⁾	I (Y) = 0V, Y (I) = V _{CC}	100			mA
V _H	Input Hysteresis at Control Pins			150		mV
RON	Switch On Resistance ⁽⁴⁾	V _{CC} = Min., V _{IN} = 0.0V, I _{ON} = 48 mA V _{CC} = Min., V _{IN} = 2.4V, I _{ON} = 15 mA		5 10	7 15	ohm

Notes:

- For Max. or Min. conditions, use appropriate value specified under Electrical Characteristics for the applicable device type.
- Typical values are at V_{CC} = 5.0V, T_A = 25°C ambient and maximum loading.
- Not more than one output should be shorted at one time. Duration of the test should not exceed one second.
- Measured by the voltage drop between I and Y pin at indicated current through the switch. ON resistance is determined by the lower of the voltages on the two (I,Y) pins.

Capacitance (T_A = 25°C, f = 1 MHz)

Parameters ⁽⁵⁾	Description	Test Conditions	Max.	Units
C _{IN}	Input Capacitance	V _{IN} = 0V	6	pF
C _{OFF}	In/Yn Capacitance, Switch Off	V _{IN} = 0V	6	pF
C _{ON}	In/Yn Capacitance, Switch On	V _{IN} = 0V	14	pF

Notes:

- This parameter is determined by device characterization but is not production tested.

Power Supply Characteristics

Parameters	Description	Test Conditions ⁽¹⁾		Min.	Typ ⁽²⁾	Max.	Units
I _{CC}	Quiescent Power Supply Current	V _{CC} = Max.	V _{IN} = GND or V _{CC}		0.1	3.0	μA
ΔI _{CC}	Supply Current per Input @ TTL HIGH	V _{CC} = Max.	V _{IN} = 3.4V ⁽³⁾			2.5	mA
I _{CCD}	Supply Current per Input per MHz ⁽⁴⁾	V _{CC} = Max., I and Y Pins Open \overline{BE} = GND Control Input Toggling 50% Duty Cycle				0.25	mA/ MHz

Notes:

1. For Max. or Min. conditions, use appropriate value specified under Electrical Characteristics for the applicable device.
2. Typical values are at V_{CC} = 5.0V, +25°C ambient.
3. Per TTL driven input (V_{IN} = 3.4V, control inputs only); I and Y pins do not contribute to I_{CC}.
4. This current applies to the control inputs only and represent the current required to switch internal capacitance at the specified frequency. The I and Y inputs generate no significant AC or DC currents as they transition. This parameter is not tested, but is guaranteed by design.

Switching Characteristics over Operating Range

Parameters	Description	Conditions ⁽¹⁾	PI5C33X257		Unit
			Com.		
			Min.	Max.	
t _{IY}	Propagation Delay ^(2,3) In to Y _n	C _L = 50 pF R _L = 500-ohm		0.25	ns
t _{SY}	Bus Select Time S _n to Y _n		0.5	5.2	ns
t _{PZH}	Bus Disable Time \overline{E} to Y _n		0.5	4.8	ns
t _{PZL}	Bus Disable Time \overline{E} to Y _n		0.5	5.0	ns
t _{PHZ}	Bus Disable Time \overline{E} to Y _n		0.5	5.0	ns

Notes:

1. See test circuit and waveforms.
2. This parameter is guaranteed but not tested on Propagation Delays.
3. The bus switch contributes no propagational delay other than the RC delay of the ON resistance of the switch and the load capacitance. The time constant for the switch alone is of the order of 0.25ns for 50pF load. Since this time constant is much smaller than the rise/fall times of typical driving signals, it adds very little propagational delay to the system. Propagation delay of the bus switch when used in a system is determined by the driving circuit on the driving side of the switch and its interaction with the load on the driven side.

Test Circuits

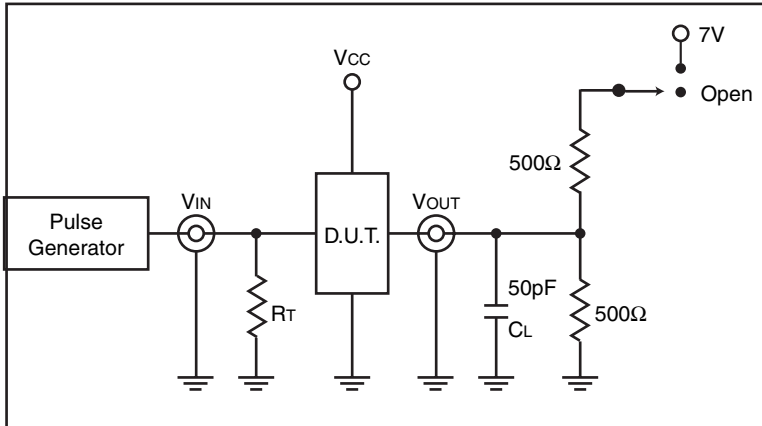

Switch Position

Test	Switch
Disable LOW	Closed
Enable LOW	Closed
t_{PD}	Open

Definitions:
 C_L = Load capacitance (includes jig and probe capacitance)
 R_T = Termination resistance (should be equal to Z_{OUT} of the pulse generator)

Enable and Disable Timing

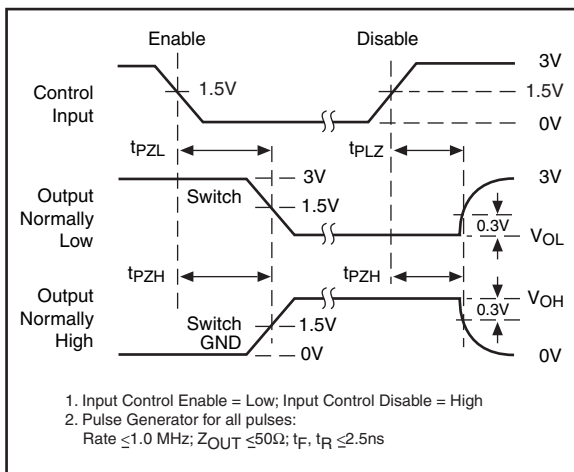

Propagation Delay

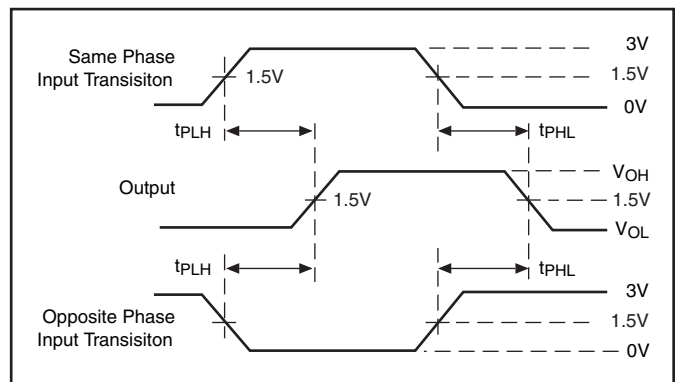

Packaging Mechanical: 48-pin BQSOP (B)

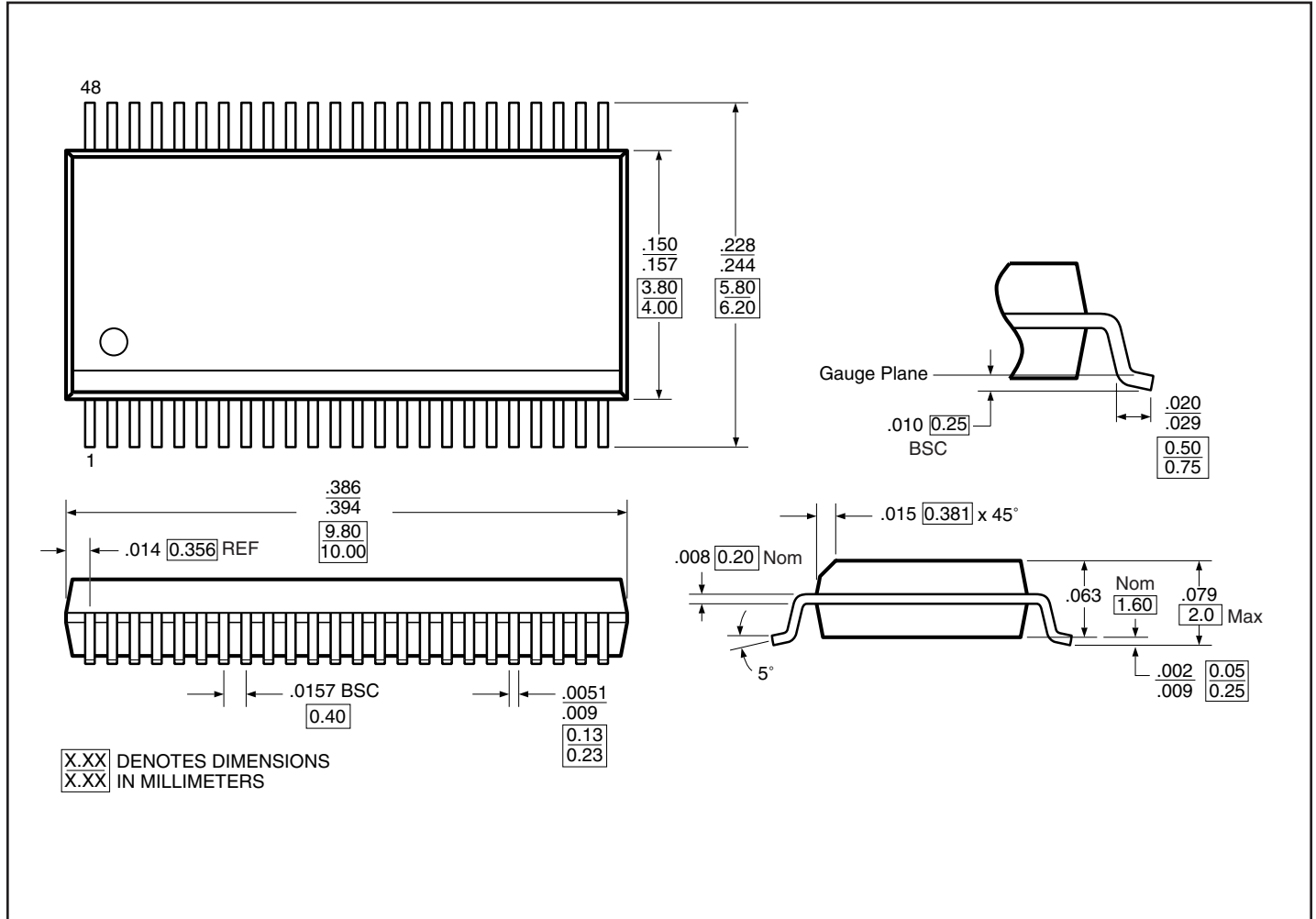

Ordering Information

Ordering Code	Packaging Code	Package Type
PI5C33X257B	B	48-pin, 150 mil wide plastic BQSOP
PI5C33X257BE	B	Pb-free & Green, 48-pin, 150 mil wide plastic BQSOP

Notes:

- Thermal characteristics can be found on the company web site at www.pericom.com/packaging/
- E = Pb-free & Green
- Adding X suffix = Tape/Reel

Компания «Life Electronics» занимается поставками электронных компонентов импортного и отечественного производства от производителей и со складов крупных дистрибьюторов Европы, Америки и Азии.

С конца 2013 года компания активно расширяет линейку поставок компонентов по направлению коаксиальный кабель, кварцевые генераторы и конденсаторы (керамические, пленочные, электролитические), за счёт заключения дистрибьюторских договоров

Мы предлагаем:

- Конкуренеспособные цены и скидки постоянным клиентам.
- Специальные условия для постоянных клиентов.
- Подбор аналогов.
- Поставку компонентов в любых объемах, удовлетворяющих вашим потребностям.
- Приемлемые сроки поставки, возможна ускоренная поставка.
- Доставку товара в любую точку России и стран СНГ.
- Комплексную поставку.
- Работу по проектам и поставку образцов.
- Формирование склада под заказчика.
- Сертификаты соответствия на поставляемую продукцию (по желанию клиента).
- Тестирование поставляемой продукции.
- Поставку компонентов, требующих военную и космическую приемку.
- Входной контроль качества.
- Наличие сертификата ISO.

В составе нашей компании организован Конструкторский отдел, призванный помогать разработчикам, и инженерам.

Конструкторский отдел помогает осуществить:

- Регистрацию проекта у производителя компонентов.
- Техническую поддержку проекта.
- Защиту от снятия компонента с производства.
- Оценку стоимости проекта по компонентам.
- Изготовление тестовой платы монтаж и пусконаладочные работы.



Тел: +7 (812) 336 43 04 (многоканальный)
Email: org@lifeelectronics.ru