



**LAN91C110 REV. B**

## **FEAST Fast Ethernet Controller for PCMCIA and Generic 16-Bit Applications**

### **PRODUCT FEATURES**

**Data Brief**

- Dual Speed CSMA/CD Engine (10 Mbps and 100 Mbps)
- Compliant with IEEE 802.3 100BASE-T Specification
- Supports 100BASE-TX, 100BASE-T4
- 16 Bit Wide Data Path (into Packet Buffer Memory)
- Generic 16-bit System Level Interface Easily Adaptable to ISA, PCMCIA (16-bit CardBus), and Various CPU System Interfaces
- Support for 16 and 8 Bit CPU Accesses
- Asynchronous Bus Interface
- 128 Kbyte External Memory
- Built-in Transparent Arbitration for Slave Sequential Access Architecture
- Flat MMU Architecture with Symmetric Transmit and Receive Structures and Queues
- IEEE-802.3 MII (Media Independent Interface) Compliant MAC-PHY Interface Running at Nibble Rate
- MII Management Serial Interface
- IEEE-802.3u Full Duplex Capability
- 144 Pin TQFP lead-free RoHS Compliant package (1.0 Millimeter Height)

**ORDER NUMBER(S):**

**LAN91C110-PU for 144 pin, TQFP Lead-Free RoHS Compliant Package**



80 ARKAY DRIVE, HAUPPAUGE, NY 11788 (631) 435-6000, FAX (631) 273-3123

Copyright © 2008 SMSC or its subsidiaries. All rights reserved.

Circuit diagrams and other information relating to SMSC products are included as a means of illustrating typical applications. Consequently, complete information sufficient for construction purposes is not necessarily given. Although the information has been checked and is believed to be accurate, no responsibility is assumed for inaccuracies. SMSC reserves the right to make changes to specifications and product descriptions at any time without notice. Contact your local SMSC sales office to obtain the latest specifications before placing your product order. The provision of this information does not convey to the purchaser of the described semiconductor devices any licenses under any patent rights or other intellectual property rights of SMSC or others. All sales are expressly conditional on your agreement to the terms and conditions of the most recently dated version of SMSC's standard Terms of Sale Agreement dated before the date of your order (the "Terms of Sale Agreement"). The product may contain design defects or errors known as anomalies which may cause the product's functions to deviate from published specifications. Anomaly sheets are available upon request. SMSC products are not designed, intended, authorized or warranted for use in any life support or other application where product failure could cause or contribute to personal injury or severe property damage. Any and all such uses without prior written approval of an Officer of SMSC and further testing and/or modification will be fully at the risk of the customer. Copies of this document or other SMSC literature, as well as the Terms of Sale Agreement, may be obtained by visiting SMSC's website at <http://www.smisc.com>. SMSC is a registered trademark of Standard Microsystems Corporation ("SMSC"). Product names and company names are the trademarks of their respective holders.

**SMSC DISCLAIMS AND EXCLUDES ANY AND ALL WARRANTIES, INCLUDING WITHOUT LIMITATION ANY AND ALL IMPLIED WARRANTIES OF MERCHANTABILITY, FITNESS FOR A PARTICULAR PURPOSE, TITLE, AND AGAINST INFRINGEMENT AND THE LIKE, AND ANY AND ALL WARRANTIES ARISING FROM ANY COURSE OF DEALING OR USAGE OF TRADE. IN NO EVENT SHALL SMSC BE LIABLE FOR ANY DIRECT, INCIDENTAL, INDIRECT, SPECIAL, PUNITIVE, OR CONSEQUENTIAL DAMAGES; OR FOR LOST DATA, PROFITS, SAVINGS OR REVENUES OF ANY KIND; REGARDLESS OF THE FORM OF ACTION, WHETHER BASED ON CONTRACT; TORT; NEGLIGENCE OF SMSC OR OTHERS; STRICT LIABILITY; BREACH OF WARRANTY; OR OTHERWISE; WHETHER OR NOT ANY REMEDY OF BUYER IS HELD TO HAVE FAILED OF ITS ESSENTIAL PURPOSE, AND WHETHER OR NOT SMSC HAS BEEN ADVISED OF THE POSSIBILITY OF SUCH DAMAGES.**

## General Description

---

The LAN91C110 is designed to facilitate the implementation of second generation Fast Ethernet PC Card adapters and other non-PCI connectivity products. The LAN91C110 is a digital device that implements the Media Access Control (MAC) portion of the CSMA/CD protocol at 10 and 100 Mbps, and couples it with a lean and fast data and control path system architecture to ensure that the CPU to packet RAM data movement does not cause a bottleneck at 100 Mbps.

The LAN91C110 implements a generic 16-bit host interface which is adaptable to a wide range of system buses and CPUs. This makes the LAN91C110 ideal for 10/100 Fast Ethernet implementations in systems based on system buses other than PCI.

Total memory size is 128 Kbytes, equivalent to a total chip storage (transmit plus receive) of 64 outstanding packets. The LAN91C110 is software compatible with the LAN9000 family of products in the default mode and can use existing LAN9000 drivers (ODI, IPX, and NDIS) with minor modifications in 16 and 32 bit Intel X86 based environments.

Memory management is handled using a unique patented MMU (Memory Management Unit) architecture and an internal 32-bit wide data path. This I/O mapped architecture can sustain back-to-back frame transmission and reception for superior data throughput and optimal performance. It also dynamically allocates buffer memory in an efficient buffer utilization scheme, reducing software tasks and relieving the host CPU from performing these housekeeping functions. The total memory size is 128 Kbytes (external), equivalent to a total chip storage (transmit and receive) of 64 outstanding packets.

FEAST provides a flexible slave interface for easy connectivity with industry-standard buses. The host interface is "ISA-like" and is easily adapted to a wide range of system and CPU buses such as ISA, PCMCIA, etc.

An IEEE-802.3 compliant Media Independent Interface (MII) provided on the network side of the LAN91C110. The MII interface allows the use of a wide range of MII compliant Physical Layer (PHY) devices to be used with the LAN91C110. The LAN91C110 also provides an interface to the two-line MII serial management protocol.

# Block Diagrams

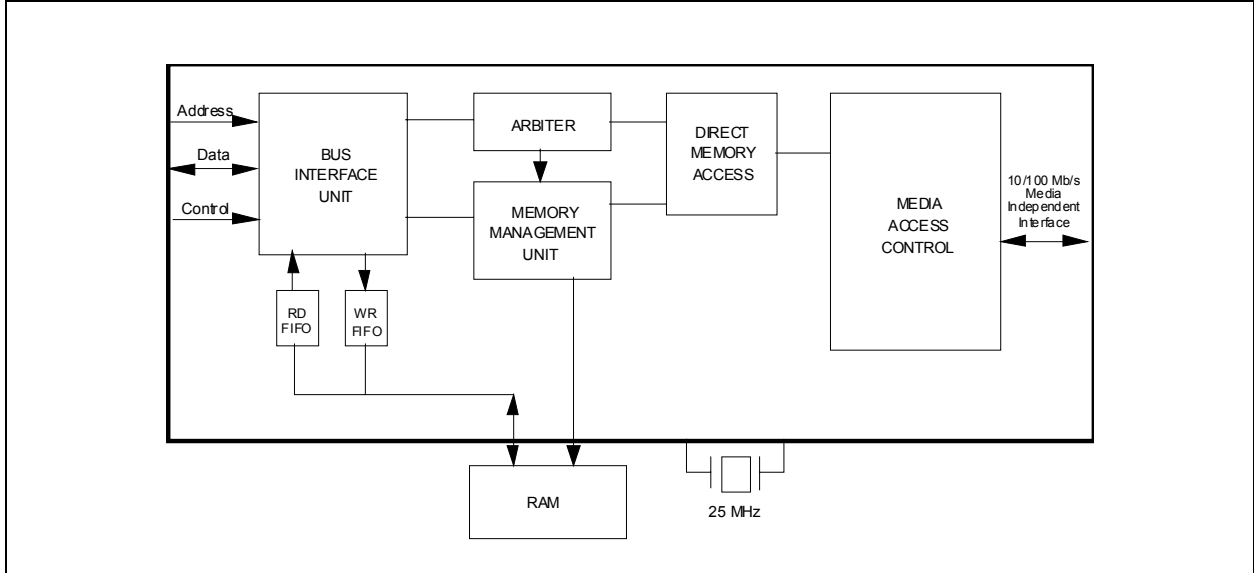

Figure 1 LAN91C110 Block Diagram

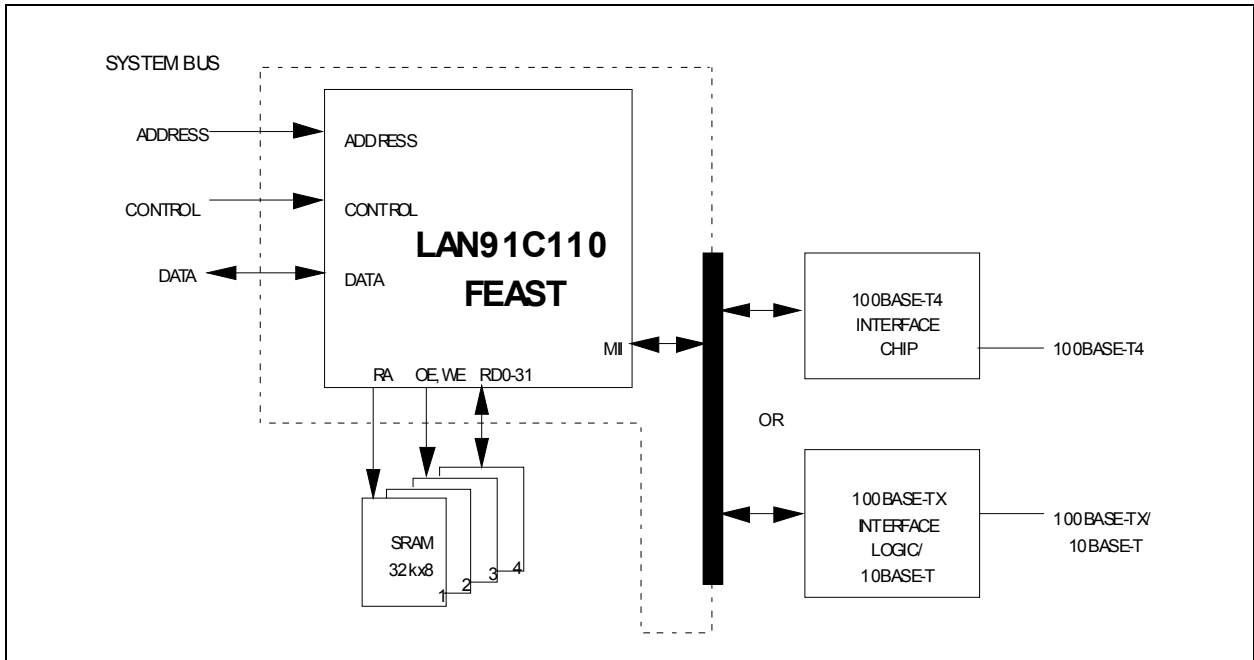

Figure 2 LAN91C110 System Diagram

## Package Outline

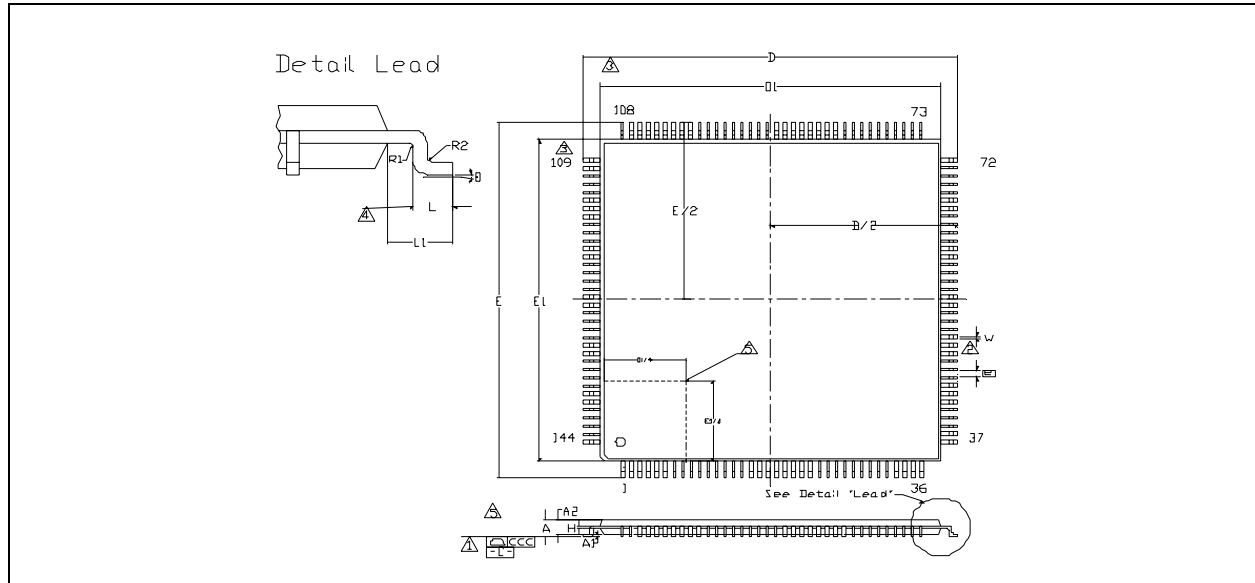

Figure 3 144 Pin TQFP Package Parameters

Table 1 144 Pin TQFP Package Parameters

	MIN	NOMINAL	MAX	REMARK
A	~	1.0	1.20	Overall Package Height
A1	0.05	0.10	0.15	Standoff
A2	0.95	1.00	1.05	Body Thickness
D	21.80	22.00	22.20	X Span
D/2	10.90	11.00	11.10	$\frac{1}{2}$ X Span Measure from Centerline
D1	19.80	20.00	20.20	X body Size
E	21.80	22.00	22.20	Y Span
E/2	10.90	11.00	11.10	$\frac{1}{2}$ Y Span Measure from Centerline
E1	19.80	20.00	20.20	Y body Size
H	0.09	~	0.20	Lead Frame Thickness
L	0.45	0.60	0.75	Lead Foot Length from Centerline
L1	~	1.00	~	Lead Length
e	0.50 Basic			Lead Pitch
?	0°	3.5°	7°	Lead Foot Angle
W	0.13	0.18	0.23	Lead Width
R1	0.08	~	~	Lead Shoulder Radius
R2	0.08	~	0.20	Lead Foot Radius
ccc	~	~	0.0762	Max Coplanarity (Assemblers)
ccc	~	~	0.08	Max Coplanarity (Test House)

**Note 1** Controlling Unit: millimeter

**Note 2** Tolerance on the position of the leads is  $\pm 0.04$  mm maximum.

**Note 3** Package body dimensions D1 and E1 do not include the mold protrusion. Maximum mold protrusion is 0.25 mm.

**Note 4** Dimension for foot length L measured at the gauge plane 0.25 mm above the seating plane is 0.78-1.08 mm.

**Note 5** Details of pin 1 identifier are optional but must be located within the zone indicated.

Компания «Life Electronics» занимается поставками электронных компонентов импортного и отечественного производства от производителей и со складов крупных дистрибьюторов Европы, Америки и Азии.

С конца 2013 года компания активно расширяет линейку поставок компонентов по направлению коаксиальный кабель, кварцевые генераторы и конденсаторы (керамические, пленочные, электролитические), за счёт заключения дистрибьюторских договоров

Мы предлагаем:

- Конкурентоспособные цены и скидки постоянным клиентам.
- Специальные условия для постоянных клиентов.
- Подбор аналогов.
- Поставку компонентов в любых объемах, удовлетворяющих вашим потребностям.
- Приемлемые сроки поставки, возможна ускоренная поставка.
- Доставку товара в любую точку России и стран СНГ.
- Комплексную поставку.
- Работу по проектам и поставку образцов.
- Формирование склада под заказчика.
- Сертификаты соответствия на поставляемую продукцию (по желанию клиента).
- Тестирование поставляемой продукции.
- Поставку компонентов, требующих военную и космическую приемку.
- Входной контроль качества.
- Наличие сертификата ISO.

В составе нашей компании организован Конструкторский отдел, призванный помогать разработчикам, и инженерам.

Конструкторский отдел помогает осуществить:

- Регистрацию проекта у производителя компонентов.
- Техническую поддержку проекта.
- Защиту от снятия компонента с производства.
- Оценку стоимости проекта по компонентам.
- Изготовление тестовой платы монтаж и пусконаладочные работы.



Тел: +7 (812) 336 43 04 (многоканальный)

Email: [org@lifeelectronics.ru](mailto:org@lifeelectronics.ru)