

Description

The AP3127/H is a current mode PWM controller which is optimized for high performance, low standby power and cost effective offline flyback converters. The AP3127/H coordinating with Diodes' secondary side controller AP4320 and protocol decoding IC AP4370 provide a Flyback charger/adaptor solution compatible to Qualcomm Quick Charge 2.0 protocol.

The PWM switching frequency at normal operation is internally fixed (about 65kHz for AP3127 and 100kHz for AP3127H). In middle load, the IC will enter green mode to improve system efficiency with the help of frequency foldback. A minimum switching frequency (about 20kHz) is set to avoid the audible noise. In no load or light load, the IC will enter the burst mode to minimize standby power. Furthermore, the frequency dithering function is built-in to reduce EMI emission.

Internal slope compensation allows more stable Peak-Current Mode control over wide range of input voltage and load conditions. Internal line compensation ensures constant output power limit over entire universal line voltage range.

Comprehensive protection features are included, such as cycle-by-cycle current limit (OCP), VCC Over Voltage Protection (VOVP), internal OTP, Over Load Protection (OLP) and pins' fault protection. AP3127/H combines secondary side OVP (SOVP) and UVP.

Features

- Very Low Start-up Current
- Current Mode Control
- Non-audible-noise Green-mode Control
- Internal Slope Compensation
- Soft Start During Startup Process
- Frequency Fold Back for High Average Efficiency
- Secondary Winding Short Protection with FOCP
- Soft Switching for Reducing EMI
- VCC Maintain Mode
- Useful Pin Fault Protection:
 - SENSE Pin Floating
 - FB/Opto-coupler Open/Short
- Comprehensive System Protection Feature:
 - VCC Over Voltage Protection (VOVP)
 - Over Load Protection (OLP)
- Secondary Side OVP (SOVP) and UVP
- Mini Size Package of SOT26
- **Totally Lead-free & Fully RoHS Compliant (Notes 1 & 2)**
- **Halogen and Antimony Free. "Green" Device (Note 3)**

Notes: 1. No purposely added lead. Fully EU Directive 2002/95/EC (RoHS) & 2011/65/EU (RoHS 2) compliant.
 2. See http://www.diodes.com/quality/lead_free.html for more information about Diodes Incorporated's definitions of Halogen- and Antimony-free, "Green" and Lead-free.
 3. Halogen- and Antimony-free "Green" products are defined as those which contain <900ppm bromine, <900ppm chlorine (<1500ppm total Br + Cl) and <1000ppm antimony compounds.

Pin Assignments

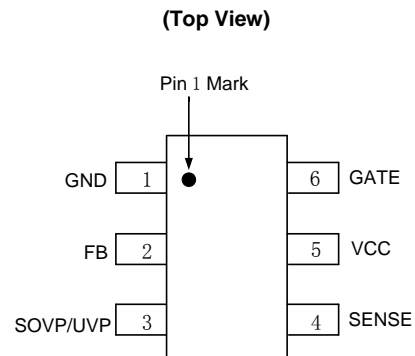

SOT26

Applications

- Quick Charger
- Switching AC-DC Adapter/Charger
- ATX/BTX Auxiliary Power
- Set-top Box (STB) Power Supply
- Open Frame Switching Power Supply

Functional Block Diagram

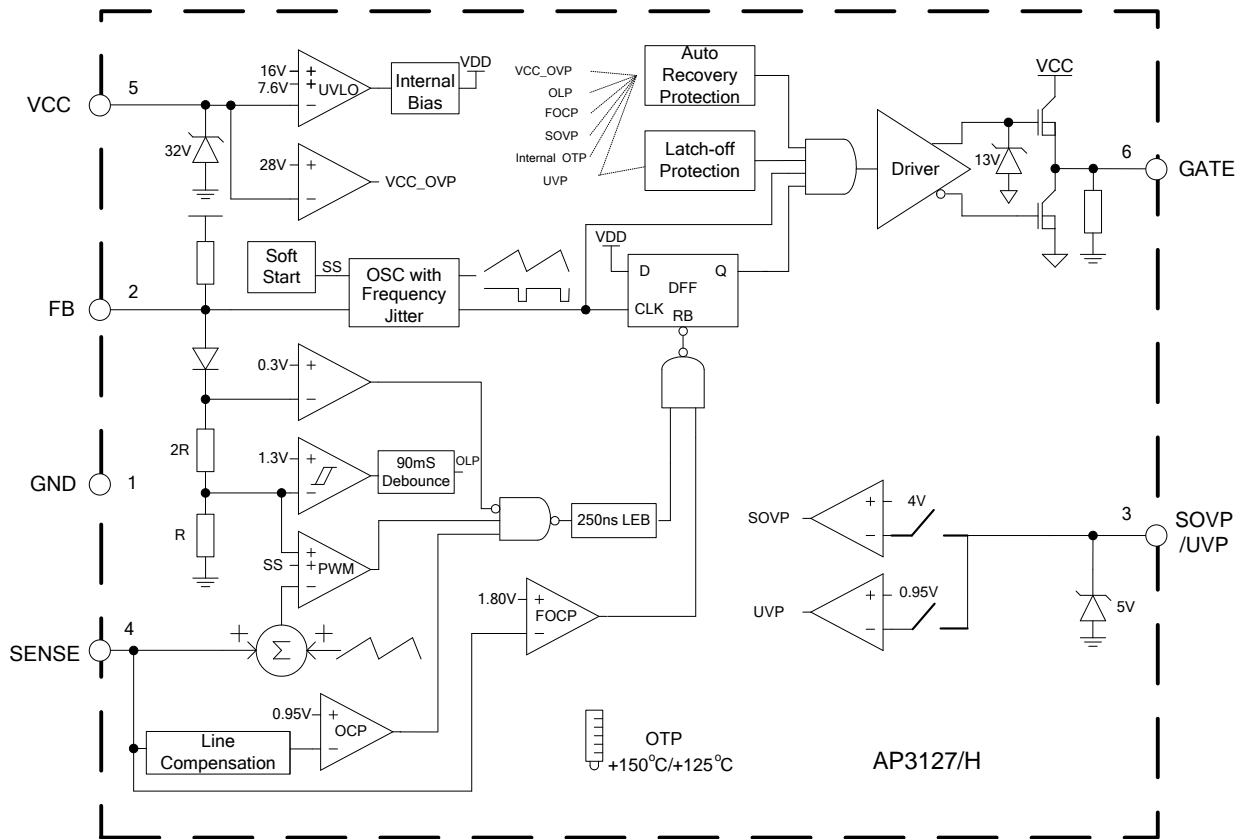

NEW PRODUCT

Absolute Maximum Ratings (Note 4)

Symbol	Parameter	Rating	Unit
V_{CC}	Power Supply Voltage	33	V
I_O	Gate Output Current	350	mA
$V_{FB}, V_{SENSE}, V_{SOVP/UVLP}$	Input Voltage to FB, SENSE, SOVP/UVLP	-0.3 to 7	V
θ_{JA}	Thermal Resistance (Junction to Ambient)	250	$^{\circ}C/W$
P_D	Power Dissipation at $T_A < +25^{\circ}C$	500	mW
T_J	Operating Junction Temperature	-40 to +150	$^{\circ}C$
T_{STG}	Storage Temperature Range	+150	$^{\circ}C$
-	ESD (Human Body Model)	3000	V
-	ESD (Machine Model)	300	V

Note 4: Stresses greater than those listed under "Absolute Maximum Ratings" may cause permanent damage to the device. These are stress ratings only, and functional operation of the device at these or any other conditions beyond those indicated under "Recommended Operating Conditions" is not implied. Exposure to "Absolute Maximum Ratings" for extended periods may affect device reliability.

Recommended Operating Conditions

Symbol	Parameter	Min	Max	Unit
V_{CC}	Supply Voltage	10	28	V

Electrical Characteristics (@T_A = +25°C, V_{CC} = 16V, unless otherwise specified.)

Symbol	Parameter	Conditions	Min	Typ	Max	Unit
Supply Voltage (VCC Pin)						
I _{STARTUP}	Startup Current	–	–	1	5	μA
I _{CC}	Operating Supply Current	V _{FB} =0V, C _L =1nF	0.5	0.7	1	mA
		V _{FB} =3V, C _L =0nF	0.6	1.2	2.0	
–	UVLO _(on)	–	14.5	15.8	16.5	V
–	V _{CC} Maintain	–	8.1	8.6	9.1	V
–	UVLO _(off)	–	7.1	7.6	8	V
–	V _{CC} OVP	–	29	30	31	V
PWM Section/Oscillator Section						
–	Maximum Duty Cycle	–	70	75	80	%
–	Oscillation Frequency	AP3127,Central Frequency	60	65	70	kHz
–	Oscillation Frequency	AP3127H,Central Frequency	93	100	107	kHz
–	Green Mode Frequency	–	20	–	30	kHz
–	Frequency Temperature Stability	-20°C to +125°C (Note 5)	–	–	5	%
–	Frequency Voltage Stability	V _{CC} =12V to 30V	–	–	3	%
–	Frequency Dithering	–	±4	±6	±8	%
Current Sense Section (SENSE Pin)						
V _{CS}	Maximum SENSE Voltage	V _{FB} =4.5V	0.9	0.95	0.98	V
–	FOCP Voltage	–	1.5	1.7	1.9	V
–	LEB Time of SENSE	–	150	250	350	ns
–	Delay to Output (Note 5)	–	–	100	–	ns
–	Soft-start Time	–	3	5	8	ms
Feedback Input Section (FB Pin)						
–	The Ratio of Input Voltage to Current Sense Voltage	–	2.5	3	3.5	V/V
–	Input Impedance	–	12	15	18	kΩ
–	Source Current	V _{FB} =0V	-0.2	-0.27	-0.34	mA
–	Green Mode Threshold	–	–	2.3	–	V
–	Input Voltage for Zero Duty	–	1.3	1.55	1.8	V
Output Section (GATE Pin)						
–	Output Low Level	I _O =20mA, V _{CC} =12V	–	–	1	V
–	Output High Level	I _O =20mA, V _{CC} =12V	8	–	–	V
–	Output Clamping Voltage	–	11	13	15	V
–	Rising Time	C _L =1nF, V _{CC} =13V	–	220	320	ns
–	Falling Time	C _L =1nF, V _{CC} =13V	–	50	100	ns

Electrical Characteristics (Cont.) (@T_A = +25°C, V_{CC} = 16V, unless otherwise specified.)

Symbol	Parameter	Conditions	Min	Typ	Max	Unit
Protection Section (SOVP/UVF Pin)						
–	OVP Reference Voltage	–	3.8	4	4.2	V
–	UVF Reference Voltage	–	0.925	0.95	0.975	V
Delay Time Section						
–	Delay of Short Circuit Protection	–	70	90	110	ms
–	Delay of Hiccup Protection (Note 5)	VCC OVP	–	6	–	Cycles
Internal OTP Section						
–	OTP Enter (Note 5)	–	–	+150	–	°C
–	OTP Exit (Note 5)	–	–	+125	–	°C

Note 5: Guaranteed by design.

Performance Characteristics

Startup Voltage vs. Ambient Temperature

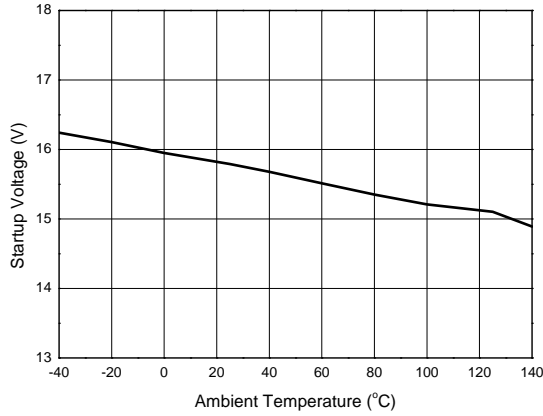

Shutdown Voltage vs. Ambient Temperature

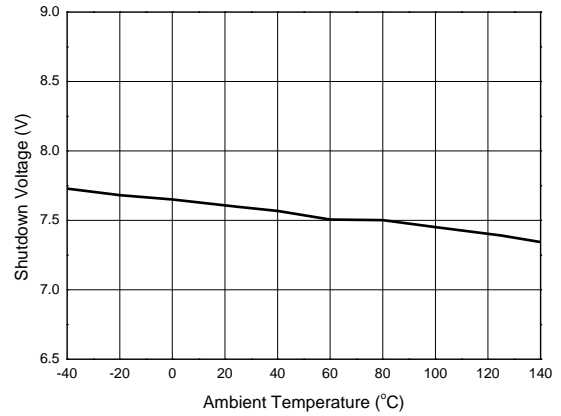

Startup Current vs. Ambient Temperature

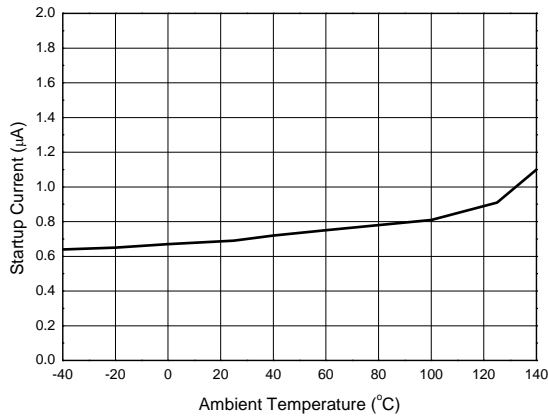

Operating Current vs. Ambient Temperature

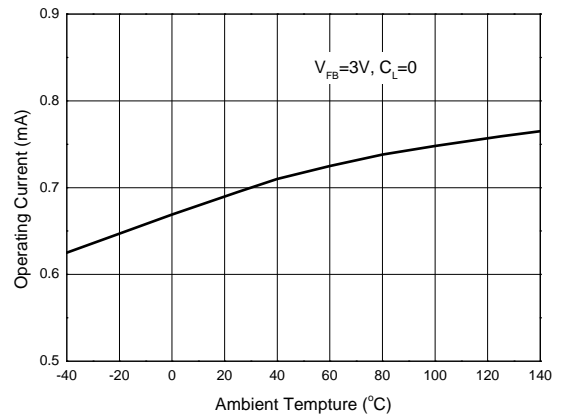

PIN3 Utilization for SOVP/UEP

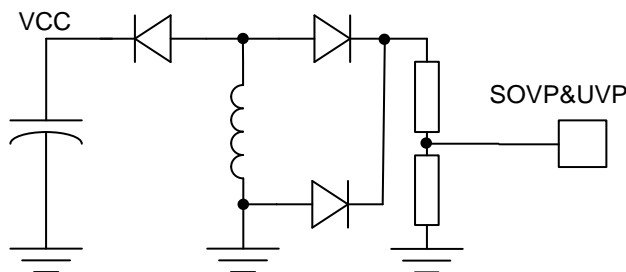

SOVP and UEP

NEW PRODUCT

Operation Description

The AP3127/H is specifically designed for off-line AC-DC power supply used in LCD monitor, notebook adapter and battery charger applications. It offers a cost effective solution with a versatile protection function.

Start-up Current and UVLO

The start-up current of AP3127/H is optimized to realize ultra low current (1μA typical) so that VCC capacitor can be charged more quickly. The direct benefit of low start-up current is the availability of using large start-up resistor, which minimizes the resistor power loss for high voltage AC input.

An UVLO comparator is included in AP3127/H to detect the voltage on VCC pin. It ensures that AP3127/H can draw adequate energy from hold-up capacitor during power-on. The turn-on threshold is 16V and the turn-off threshold is 7.6V.

Current Sense Comparator and PWM Latch

The AP3127/H operates as a current mode controller, the output switch conduction is initiated by every oscillator cycle and is terminated when the peak inductor current reaches the threshold level established by the FB pin. The inductor current signal is converted to a voltage signal by inserting a reference sense resistor R_S . The inductor current under normal operating conditions is controlled by the voltage at FB pin. The relation between peak inductor current (I_{PK}) and V_{FB} is:

$$I_{PK} = (V_{FB} - 0.8) / 3R_S$$

Moreover, FOCP with 1.8V threshold is only about 100ns delay, which can avoid some catastrophic damages such as secondary rectifier short test. Few drive cycles can alleviate the destruction range and get better protection.

Leading-edge Blanking

A narrow spike on the leading edge of the current waveform can usually be observed when the power MOSFET is turned on. A 250ns leading-edge blank is built-in to prevent the false-triggering caused by the turn-on spike. During this period, the current limit comparator is disabled and the gate driver can not be switched off.

At the time of turning off the MOSFET, a negative undershoot (maybe larger than -0.3V) can occur on the SENSE pin. So it is strongly recommended to add a small RC filter or at least connect a resistor "R" on this pin to protect the IC (Shown as Figure 1).

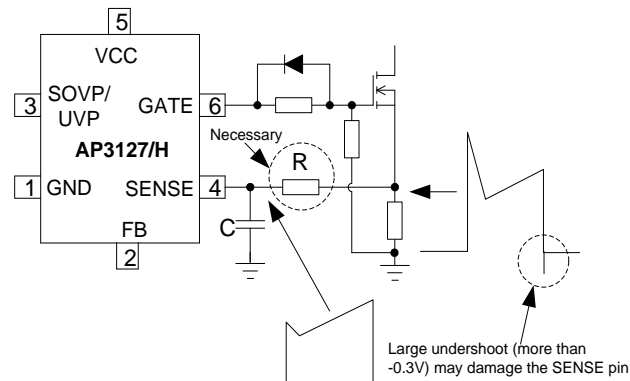

Figure 1

Built-in Slope Compensation

It is well known that a continuous current mode SMPS may become unstable when the duty cycle exceeds 50%. The built-in slope compensation can improve the stability, so there is no need for design engineer to spend much time on that.

FB Pin and Short Circuit Protection

This pin is normally connected to the opto-coupler and always paralleled with a capacitor for loop compensation. When the voltage at this pin is greater than 4.5V and lasts for about 90ms, the IC will enter the protection mode. For AP3127/H, the system will enter hiccup mode to wait the V_{CC} decreasing to low UVLO level, then the IC will try to restart until the failure removed. And when this voltage is less than 1.55V, the IC will stop the drive pulse immediately. Therefore, this feature can be used for short circuit protection, which makes the system immune from damage. Normally, output short makes the V_{FB} value to the maximum because the opto-coupler is cut off.

Operation Description (Cont.)

V_{CC} Maintain Mode

During light load or step load, V_{FB} will drop and be lower than 1.55V, thus the PWM drive signal will be stopped, and there is no more new energy transferred due to no switching. Therefore, the IC supply voltage may reduce to the shutdown threshold voltage and system may enter the unexpected restart mode. To avoid this, the AP3127/H holds a so-called V_{CC} maintain mode which can supply energy to VCC.

When V_{CC} decreases to a setting threshold, the V_{CC} maintain comparator will output some drive signal to make the system switch and provide a proper energy to VCC pin. The V_{CC} maintain function will cooperate with the PWM and burst mode loop which can make the output voltage variation be within the regulation. This mode is very useful for reducing startup resistor loss and achieving a better standby performance with a low value VCC capacitor. The V_{CC} is not easy to touch the shutdown threshold during the startup process and step load. This will also simplify the system design. The minimum VCC voltage is suggested to be designed a little higher than V_{CC} maintain threshold thus can achieve the best balance between the standby and step load performance.

System Protection and Pin Fault Protection

The AP3127/H provides versatile system and pin fault protections. The OCP comparator realizes the cycle-by-cycle current limiting (OCP). In universal input line voltage, the IC realizes the constant over load protection (OLP). VCC over voltage protection can be applied as the primary OVP or opto-coupler broken protection. The AP3127/H also has pin fault connection protection including floating and short connection. The floating pin protection includes the SENSE, FB, etc. The short pin protection includes the SOVP/UVP pin short protection. When these pins are floated or SOVP/UVP pin is shorted to ground, PWM switching will be disabled, thus protecting the power system.

SOVP/UVP Protection Function

For some applications, the system requires the output over voltage and under voltage protection function. The SOVP/UVP pin compares the divided voltage from the VCC winding with the inner threshold, when the voltage between R1 and R2 (as in Figure 2) is higher than 4V or lower than 0.95V in switch turning off duration, AP3127/H will trigger SOVP or UVP function and the system will enter the Auto-recovery protection mode. Since the value of VCC winding's waveform reflects the output voltage precisely, the output OVP and UVP can be realized by this function.

D2 in Figure 2 is adopted to clamp the negative signal from VCC winding as a noise immunity solution.

Internal OTP Protection Function

The AP3127/H integrates an internal temperature sensor. It has a trigger window of entering OTP mode at +150°C and exiting at +125°C. The internal OTP protection mode is auto-recovery mode.

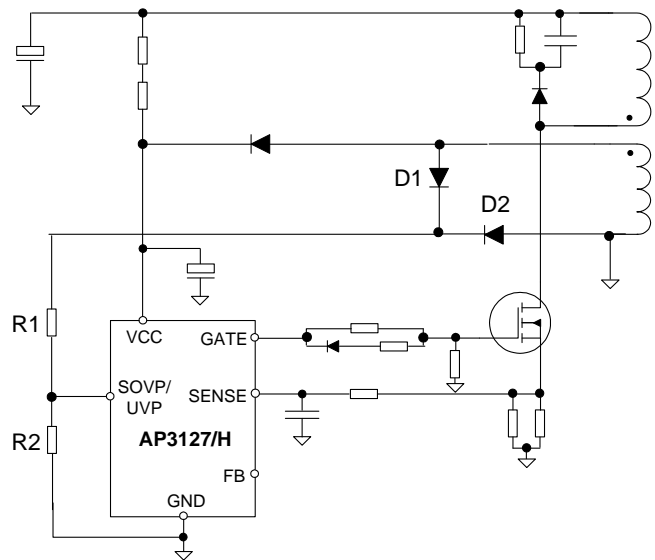
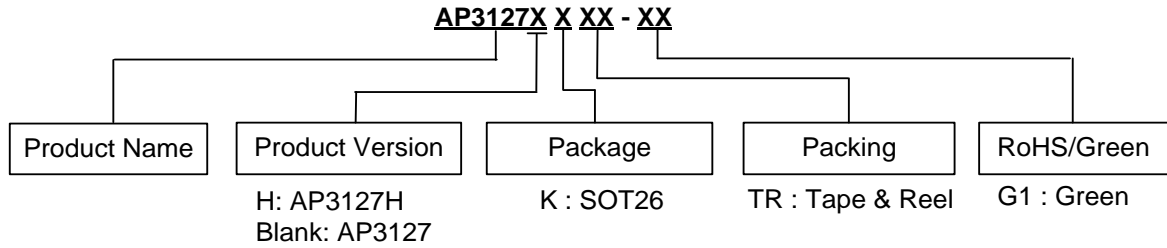

Figure 2

NEW PRODUCT

Ordering Information



Package	Part Number	Marking ID	Packing
SOT26	AP3127KTR-G1	GPH	3000/Tape & Reel
	AP3127HKTR-G1	GSH	3000/Tape & Reel

Marking Information

(Top View)

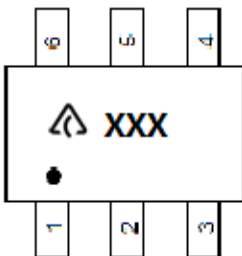

 : Logo
 XXX: Marking ID (See Ordering Information)

NEW PRODUCT

Package Outline Dimensions (All dimensions in mm(inch).)

(1) Package Type: SOT26

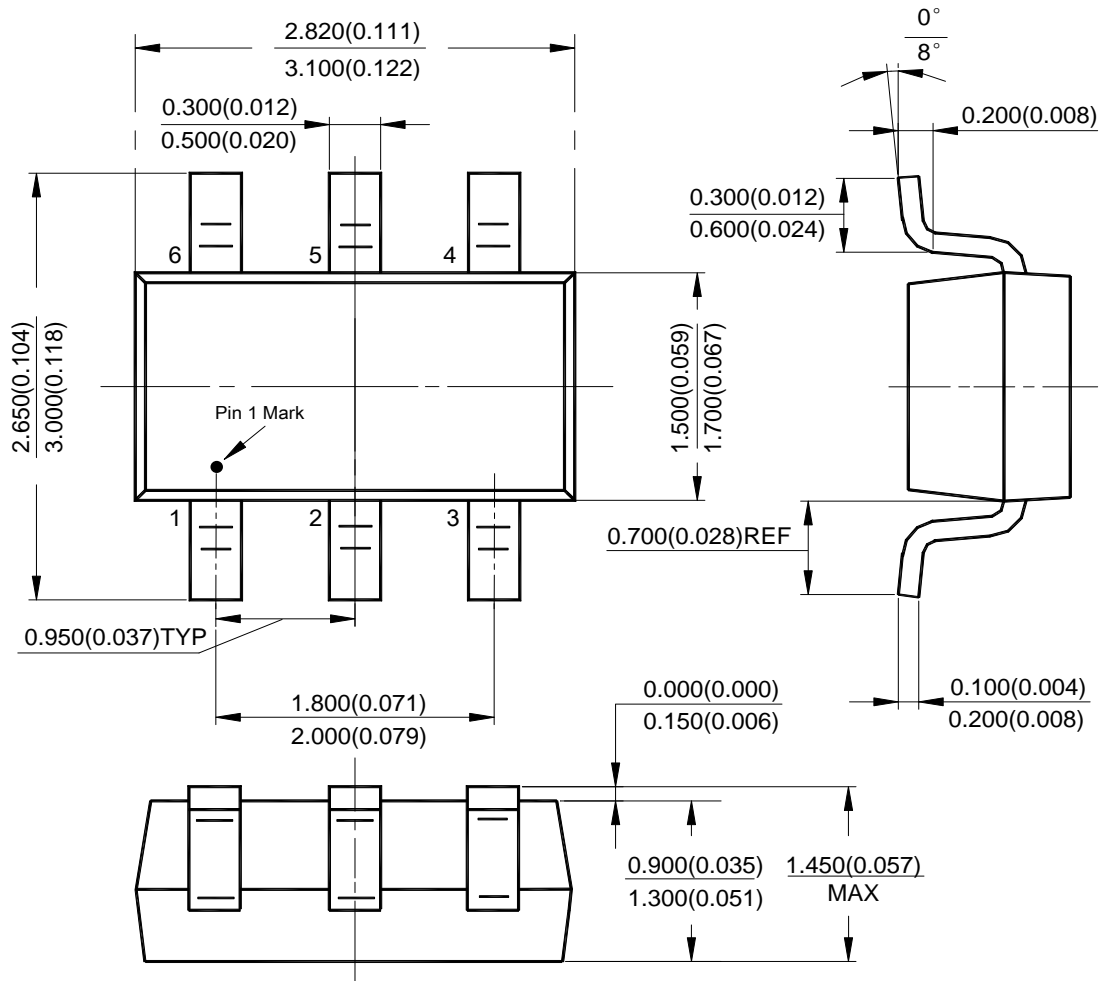

NEW PRODUCT

Suggested Pad Layout

(1) Package Type: SOT26

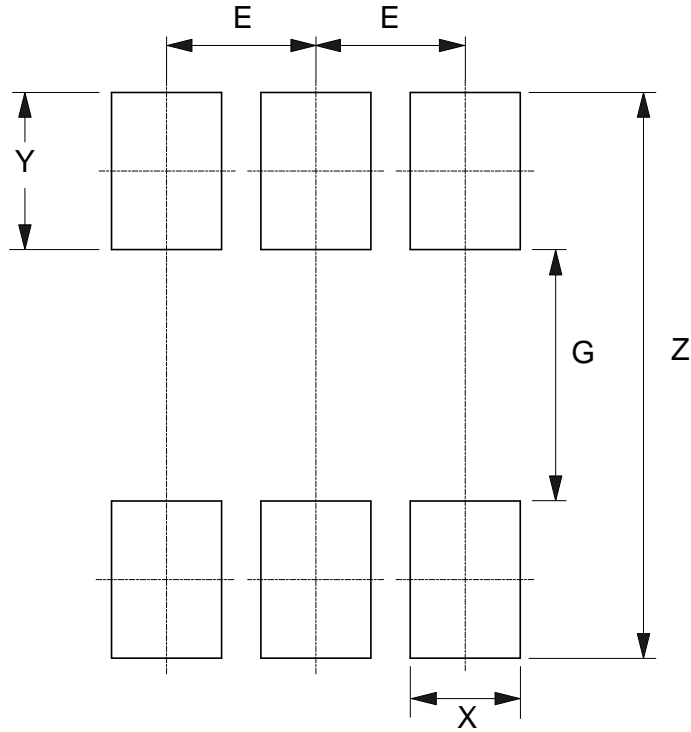

Dimensions	Z (mm)/(inch)	G (mm)/(inch)	X (mm)/(inch)	Y (mm)/(inch)	E (mm)/(inch)
Value	3.600/0.142	1.600/0.063	0.700/0.028	1.000/0.039	0.950/0.037

NEW PRODUCT

IMPORTANT NOTICE

DIODES INCORPORATED MAKES NO WARRANTY OF ANY KIND, EXPRESS OR IMPLIED, WITH REGARDS TO THIS DOCUMENT, INCLUDING, BUT NOT LIMITED TO, THE IMPLIED WARRANTIES OF MERCHANTABILITY AND FITNESS FOR A PARTICULAR PURPOSE (AND THEIR EQUIVALENTS UNDER THE LAWS OF ANY JURISDICTION).

Diodes Incorporated and its subsidiaries reserve the right to make modifications, enhancements, improvements, corrections or other changes without further notice to this document and any product described herein. Diodes Incorporated does not assume any liability arising out of the application or use of this document or any product described herein; neither does Diodes Incorporated convey any license under its patent or trademark rights, nor the rights of others. Any Customer or user of this document or products described herein in such applications shall assume all risks of such use and will agree to hold Diodes Incorporated and all the companies whose products are represented on Diodes Incorporated website, harmless against all damages.

Diodes Incorporated does not warrant or accept any liability whatsoever in respect of any products purchased through unauthorized sales channel. Should Customers purchase or use Diodes Incorporated products for any unintended or unauthorized application, Customers shall indemnify and hold Diodes Incorporated and its representatives harmless against all claims, damages, expenses, and attorney fees arising out of, directly or indirectly, any claim of personal injury or death associated with such unintended or unauthorized application.

Products described herein may be covered by one or more United States, international or foreign patents pending. Product names and markings noted herein may also be covered by one or more United States, international or foreign trademarks.

This document is written in English but may be translated into multiple languages for reference. Only the English version of this document is the final and determinative format released by Diodes Incorporated.

LIFE SUPPORT

Diodes Incorporated products are specifically not authorized for use as critical components in life support devices or systems without the express written approval of the Chief Executive Officer of Diodes Incorporated. As used herein:

A. Life support devices or systems are devices or systems which:

1. are intended to implant into the body, or
2. support or sustain life and whose failure to perform when properly used in accordance with instructions for use provided in the labeling can be reasonably expected to result in significant injury to the user.

B. A critical component is any component in a life support device or system whose failure to perform can be reasonably expected to cause the failure of the life support device or to affect its safety or effectiveness.

Customers represent that they have all necessary expertise in the safety and regulatory ramifications of their life support devices or systems, and acknowledge and agree that they are solely responsible for all legal, regulatory and safety-related requirements concerning their products and any use of Diodes Incorporated products in such safety-critical, life support devices or systems, notwithstanding any devices- or systems-related information or support that may be provided by Diodes Incorporated. Further, Customers must fully indemnify Diodes Incorporated and its representatives against any damages arising out of the use of Diodes Incorporated products in such safety-critical, life support devices or systems.

Copyright © 2015, Diodes Incorporated

www.diodes.com

Компания «Life Electronics» занимается поставками электронных компонентов импортного и отечественного производства от производителей и со складов крупных дистрибьюторов Европы, Америки и Азии.

С конца 2013 года компания активно расширяет линейку поставок компонентов по направлению коаксиальный кабель, кварцевые генераторы и конденсаторы (керамические, пленочные, электролитические), за счёт заключения дистрибьюторских договоров

Мы предлагаем:

- Конкурентоспособные цены и скидки постоянным клиентам.
- Специальные условия для постоянных клиентов.
- Подбор аналогов.
- Поставку компонентов в любых объемах, удовлетворяющих вашим потребностям.
- Приемлемые сроки поставки, возможна ускоренная поставка.
- Доставку товара в любую точку России и стран СНГ.
- Комплексную поставку.
- Работу по проектам и поставку образцов.
- Формирование склада под заказчика.
- Сертификаты соответствия на поставляемую продукцию (по желанию клиента).
- Тестирование поставляемой продукции.
- Поставку компонентов, требующих военную и космическую приемку.
- Входной контроль качества.
- Наличие сертификата ISO.

В составе нашей компании организован Конструкторский отдел, призванный помогать разработчикам, и инженерам.

Конструкторский отдел помогает осуществить:

- Регистрацию проекта у производителя компонентов.
- Техническую поддержку проекта.
- Защиту от снятия компонента с производства.
- Оценку стоимости проекта по компонентам.
- Изготовление тестовой платы монтаж и пусконаладочные работы.



Тел: +7 (812) 336 43 04 (многоканальный)
Email: org@lifeelectronics.ru