

Sound Processors for BOOM BOX / Mini-component Stereo

Sound Processors with Built-in 3-band Equalizers



BD3403FV, BD3861FS, BD3883FS

No.10086EAT01

●Description

The Sound Processor has a built-in 3 Band Equalizer and can be controlled with a 2-wire serial. It is suited for a sound quality design which incorporates various functions, ranging from source selectors, such as BOOM BOX, Mini-audio systems and Micro-audio systems to preamplifiers at the front stage of the power amp.

●Features

- 1) High S/N, achieved by implementing 2-stage configuration of Front Volume and Rear Volume.
- 2) Provides surround and rear volume with Soft-switch to reduce a shock sound during switching functions(BD3883FS).
- 3) Volume and tone implemented with the resistance ladder circuit (to achieve high performance with low noise and low distortion).
- 4) Uses the BiCMOS process that achieves low-consumption current, which contributes to an energy-saving design. Using the BiCMOS process, has the advantage in quality over the scaling down of the internal regulators and heat controls.
- 5) SSOP-A32 and SSOP-B40 are used for the packages. Input pins and output pins are organized and separately laid out so as to keep the signal flows in one direction which consequently, simplify pattern layout of the set board and decrease the board dimensions.

●Applications

BOOM BOX, mini-audio systems, and micro-audio systems.

●Product lineup

Parameter	BD3403FV	BD3861FS	BD3883FS
Operating Voltage Range	6.5 to 9.5V	6.5 to 9.5V	6.5 to 9.5V
Equalizer	3 band (BASS, MIDDLE, TREBLE)	3 band (BASS, MIDDLE, TREBLE)	3 band (BASS, MIDDLE, TREBLE)
Front Volume	0 to -30dB/2dB step	0 to -50dB/2dB step -50 to -70dB/4dB step, -∞dB	0 to -87dB/1dB step, -∞dB
Rear Volume	0 to -59dB/1dB step, -∞dB	0 to -59dB/1dB step, -∞dB	0, -10dB
Input Gain	0 to 26dB/2dB step	0 to 26dB/2dB step	0, 6, 12, 16, 20, 23, 26, 29dB
Microphone Input	○	○	-
Surround	○	-	○
Package	SSOP-B40	SSOP-A32	SSOP-A32

●Absolute maximum ratings (Ta=25°C)

Parameter	Symbol	Ratings		Unit
		BD3403FV	BD3861FS, BD3883FS	
Power Supply Voltage	Vcc	10	10	V
Power Dissipation	Pd	900 ^{*1}	950 ^{*2}	mW
Input Voltage Range	Vin	GND-0.3 to VCC+0.3	GND-0.3 to VCC+0.3	V
Operating Temperature Range	Topr	-25 to +75	-25 to +75	°C
Storage Temperature Range	Tstg	-55 to +125	-55 to +125	°C

^{*1} Reduced by 9.0 mW/°C over 25°C, when installed on the standard board (size: 70×70×1.6mm) for (BD3403FV).

^{*2} Reduced by 9.5 mW/°C over 25°C, when installed on the standard board (size:70×70×1.6mm) for (BD3861FS, BD3883FS).

●Operating voltage range

Parameter	Symbol	Ratings	Unit
BD3403FV	Vcc	6.5 to 9.5	V
BD3861FS			
BD3883FS			

●Electrical characteristics

©BD3403FV

$V_{CC}=9V$, $f=1KHz$, $V_{IN}=1V_{rms}$, $R_g=600\Omega$, $R_L=10k\Omega$, $T_a=25^\circ C$, Input Gain=0dB, VOL=0dB,
Bass, Middle, Treble=0dB, Surround=OFF, unless otherwise noted.

	Parameter	Symbol	Limits			Unit	Condition
			Min.	Typ.	Max.		
TOTAL	Circuit Current	IQ	-	16.0	30.0	mA	At no signal
	Output Voltage Gain	GV	-1.5	0.0	1.5	dB	$GV=20\log(V_{OUT}/V_{IN})$
	Total Harmonic Distortion ratio	THD	-	0.02	0.08	%	400 to 30kHz BPF
	Maximum Output Voltage	VOM	2.0	2.5	-	Vrms	THD=1%
	Output Noise Voltage	VNO	-	1.8	6.0	μV_{rms}	$R_g=0k\Omega$, IHF-A
	Cross-talk between Channels	CT	-	3.0	9.0	μV_{rms}	$R_g=0k\Omega$, IHF-A
INPUT	6dBSW Gain	GV6	5	6	7	dB	$V_{IN}=200mV_{rms}$ $GV6=20\log(V_{OUT}/V_{IN})$
	Input Voltage Gain 1	Gvmax11	-1	*2	+1	dB	$V_{IN}=200mV_{rms}$, From 0 to 10dB $Gvmax11=20\log(V_{OUT}/V_{IN})$
	Input Voltage Gain 2	Gvmax12	-1.5	*2	+1.5	dB	$V_{IN}=200mV_{rms}$ From 12 to 26dB $Gvmax12=20\log(V_{OUT}/V_{IN})$
	Input Gain Switching Step	Gvmax1st	-	2	-	dB	From 0 to 26dB
	Input Total Harmonic Distortion ratio	THDI	-	0.02	0.08	%	400 to 30kHz BPF
	Input Maximum Output Voltage	VOMI	2.0	2.5	-	dB	THD=1%
	Cross-talk between Selectors	CS	-	-80.0	-70.0	dB	$R_g=0k\Omega$, IHF-A $CS=20\log(V_{OUT}/V_{IN})$
	Input Impedance	RI	35.0	50.0	65.0	k Ω	$RI=51k \times V_{OUT} / (V_{IN}-V_{OUT})$
	E Input SW Attenuation	GRE	-	-20.0	-15.0	dB	$GRE=20\log(V_{OUT}/V_{IN})$
INPUT VOLUME	Input Volume 1	GIV1	-2	*3	+2	dB	From 0 to -30dB $GIV1=20\log(V_{OUT}/V_{IN})$
	Volume Switching Step 1	GIVst1	-	2	-	dB	From 0 to -30dB
OUTPUT VOLUME	Output Volume	GOV	-1	*1	+1	dB	From 0 to -59dB $Gov=20\log(V_{OUT}/V_{IN})$
	Output Switching Step	GOVst	-	1	-	dB	From 0 to -59dB
	Maximum attenuation	GminO	-	-	-90.0	dB	IHF-A, $GminO=20\log(V_{OUT}/V_{IN})$
SURROUND	Surround Gain CH1→CH2	Gsur1	5	7	9	dB	$V_{IN}=200mV_{rms}$, $f=1kHz$
	Surround Gain CH2→CH1	Gsur2	5	7	9	dB	$V_{IN}=200V_{rms}$, $f=1kHz$
BASS	Bass Boost Gain	GBB	-2	*1	+2	dB	$V_{IN}=200mV_{rms}$, $f=90Hz$, From 0 to 14dB $GBB=20\log(V_{OUT}/V_{IN})$
	Bass Cut Gain	GBC	-2	*1	+2	dB	$V_{IN}=200mV_{rms}$, $f=90Hz$, From -14 to 0dB $GBC=20\log(V_{OUT}/V_{IN})$
	Bass Switching Step	GBST	-	2	-	dB	$V_{IN}=200mV_{rms}$, $f=90Hz$
MIDDLE	Middle Boost Gain	GMB	-2	*1	+2	dB	$V_{IN}=200mV_{rms}$, From 0 to 12dB $GMB=20\log(V_{OUT}/V_{IN})$
	Middle Cut Gain	GMC	-2	*1	+2	dB	$V_{IN}=200mV_{rms}$, From -12 to 0dB $GMC=20\log(V_{OUT}/V_{IN})$
	Middle Switching Step	GMST	-	2	-	dB	$V_{IN}=200mV_{rms}$
TREBLE	Treble Boost Gain	GTB	-2	*1	+2	dB	$V_{IN}=200mV_{rms}$, $f=10kHz$ From 0 to 12dB $GTB=20\log(V_{OUT}/V_{IN})$
	Treble Cut Gain	GTC	-2	*1	+2	dB	$V_{IN}=200mV_{rms}$, $f=10kHz$ From -12 to 0dB $GTC=20\log(V_{OUT}/V_{IN})$
	Treble Switching Step	GTST	-	2	-	dB	$V_{IN}=200mV_{rms}$, $f=10kHz$
MIC	Microphone Voltage Gain	GMIC	4.5	6.0	7.5	dB	$V_{IN}=200mV_{rms}$ $GMIC=20\log(V_{OUT}/V_{IN})$

*1 *2 Typ. is set to the value described in condition.
Min. and Max. mean the error.

ⓄBD3861FS

VCC=9V, f=1KHz, VIN=1Vrms, Rg=600Ω, RL=10kΩ, Ta=25°C, Input Gain=0dB, VOL=0dB,
Bass, Middle, Treble=0dB, unless otherwise noted.

	Parameter	Symbol	Limits			Unit	Condition
			Min.	Typ.	Max.		
TOTAL	Circuit Current	IQ	-	13.0	26.0	mA	At no signal
	Output Voltage Gain	GV	-1.5	0.0	1.5	dB	GV=20log(VOUT/VIN)
	Total Harmonic Distortion	THD	-	0.02	0.08	%	400 to 30kHz BPF
	Maximum Output Voltage	VOM	2.0	2.5	-	Vrms	THD=1%
	Output Noise Voltage	VNO	-	8.0	15.0	μVrms	Rg=0kΩ, IHF-A
	Cross-talk between Channels	CT	-	-80	-70	dB	Rg=0kΩ, IHF-A
INPUT	6dB SW Gain	GV6	5	6	7	dB	VIN=200mVrms GV6=20log(VOUT/VIN)
	Input Voltage Gain 1	Gvmax11	-1	*1	+1	dB	VIN=200mVrms From 0 to 10dB Gvmax11=20log(VOUT/VIN)
	Input Voltage Gain 2	Gvmax12	-1.5	*1	+1.5	dB	VIN=200mVrms, From 12 to 26dB Gvmax12=20log(VOUT/VIN)
	Input Gain Switching Step	Gvmax1st	-	2	-	dB	From 0 to 26dB
	Input Total Harmonic Distortion	THDI	-	0.02	0.08	%	400 to 30kHz BPF
	Input Maximum Output Voltage	VOMI	2.0	2.5	-	dB	THD=1%
	Cross-talk between Selectors	CS	-	-80.0	-70.0	dB	Rg=0kΩ, IHF-A CS=20log(VOUT/VIN)
	Input Impedance	RI	35.0	50.0	65.0	kΩ	RI=51kxVOUT/(VIN-VOUT)
INPUT VOLUME	E Input SW Attenuation	GRE	-	-20.0	-15.0	dB	GRE=20log(VOUT/VIN)
	Input Volume 1	GIV1	-2	*1	+2	dB	From 0 to -50dB GIV1=20log(VOUT/VIN)
	Input Volume 2	GIV2	-3	*1	+3	dB	From -54 to -70dB GIV2=20log(VOUT/VIN)
	Volume Switching Step 1	GIVst1	-	2	-	dB	From 0 to -50dB
	Volume Switching Step 2	GIVst2	-	4	-	dB	From -54 to -70dB
OUTPUT VOLUME	Maximum attenuation	GminI	-	-	-90.0	dB	IHF-A, GminI=20log(VOUT/VIN)
	Output Volume	GOV	-1	*1	+1	dB	From 0 to -59dB Gov=20log(VOUT/VIN)
	Output Switching Step	GOVst	-	1	-	dB	From 0 to -59dB
BASS	Maximum attenuation	GminO	-	-	-90.0	dB	IHF-A GminO=20log(VOUT/VIN)
	Bass Boost Gain	GBB	-2	*1	+2	dB	VIN=200mVrms, f=90Hz, From 0 to 14dB GBB=20log(VOUT/VIN)
	Bass Cut Gain	GBC	-2	*1	+2	dB	VIN=200mVrms, f=90Hz, From -14 to 0dB GBC=20log(VOUT/VIN)
MIDDLE	Bass Switching Step	GBST	-	2	-	dB	VIN=200mVrms, f=90Hz
	Middle Boost Gain	GMB	-2	*1	+2	dB	VIN=200mVrms, From 0 to 12dB GMB=20log(VOUT/VIN)
	Middle Cut Gain	GMC	-2	*1	+2	dB	VIN=200mVrms, From -12 to 0dB GMC=20log(VOUT/VIN)
TREBLE	Middle Switching Step	GMST	-	2	-	dB	VIN=200mVrms
	Treble Boost Gain	GTB	-2	*1	+2	dB	VIN=200mVrms, f=10kHz From 0 to 12dB GTB=20log(VOUT/VIN)
	Treble Cut Gain	GTC	-2	*1	+2	dB	VIN=200mVrms, f=10kHz From -12 to 0dB GTC=20log(VOUT/VIN)
MIC	Treble Switching Step	GTST	-	2	-	dB	VIN=200mVrms, f=10kHz
	Microphone Voltage Gain	GMIC	4.5	6.0	7.5	dB	VIN=200mVrms GMIC=20log(VOUT/VIN)

*1 Typ. is set to the value described in condition.
Min. and Max. mean the error.

⊙BD3883FS

Ta=25°C, VCC=8V, f=1kHz, Vi=200mVrms, RL=10kΩ, Rg=600Ω,

Input Selector=Ach, Input Gain=0dB, Volume=0dB, Bass=0dB, Middle=0dB, Treble=0dB,

Surround=OFF, RECOU=OFF, unless otherwise noted.

	Parameter	Symbol	Limits			Unit	Condition
			Min.	Typ.	Max.		
TOTAL	Circuit Current	IQ	-	8	21	mA	At no signal
	Total Output Voltage Gain	Gv	-2	0	2	dB	
	Total Harmonic Distortion	THDO	-	0.01	0.1	%	BW=400 to 30kHz
	Maximum Output Voltage	Vomaxo	1.6	2.1	-	Vrms	THD=1% BW=400 to 30kHz
	Total Residual Noise Voltage	Vno	-	2	10	μVrms	Rg=0Ω, Vol=-∞dB BW=IHF-A, REAR ATT=-10dB
	Total Output Noise Voltage	Vmno	-	4	15	μVrms	Rg=0Ω, Vol=0dB BW=IHF-A
	Cross-talk between Channels	CTC12	-	-80	-70	dB	Rg=0Ω, BW=IHF-A VOUT=1Vrms
	Input Impedance	Rin	70	100	130	kΩ	
	Output Impedance	Rout	-	-	50	Ω	
INPUT	Cross-talk between Selectors	CTS1	-	-80	-70	dB	VOUT=1Vrms Rg=0Ω, BW=IHF-A
VOLUME	Volume Control Range	VRI	-90	-87	-84	dB	BW=IHF-A, Vout=1Vrms
	Volume Setting Error 1	VEI1	-2	0	2	dB	0 to -53dB, BW=IHF-A VOUT=1Vrms
	Volume Setting Error 2	VEI2	-3	0	3	dB	-54 to -87dB, BW=IHF-A VOUT=1Vrms
	Maximum Attenuation	Vmin	-	-	-90	dB	BW=IHF-A VOUT=1Vrms
	Volume Input Impedance	Rvin	39	56	73	kΩ	
BASS	Bass Gain	Gb	-17.5 to +17.5			dB	
	Bass Gain Setting Error	BE	-2.5	0	-2.5	dB	
MIDDLE	Middle Gain	Gm	-14 to +14			dB	
	Middle Gain Setting Error	ME	-2	0	-2	dB	
TREBLE	Treble Gain	Gt	-14 to +14			dB	
	Treble Gain Setting Error	TE	-2	0	2	dB	
SURROUND	Surround In-phase Gain	Vsur1	-2	0	2	dB	
	Surround Single-phase Gain	Vsur2	4.3	6.3	8.3	dB	AC-grounding
	Opposite-phase Gain	Vsur3	8	10	12	dB	

• This IC is not designed to be radiation-resistant.

●Control signal specifications

1. Signal Timing Conditions

- Data is read on the rising edge of the clock.
- Latch is read on the falling edge of the clock.
- Latch signal must terminate with the LOW state.
- To avoid malfunctions, clock and data signals must terminate with the LOW state.

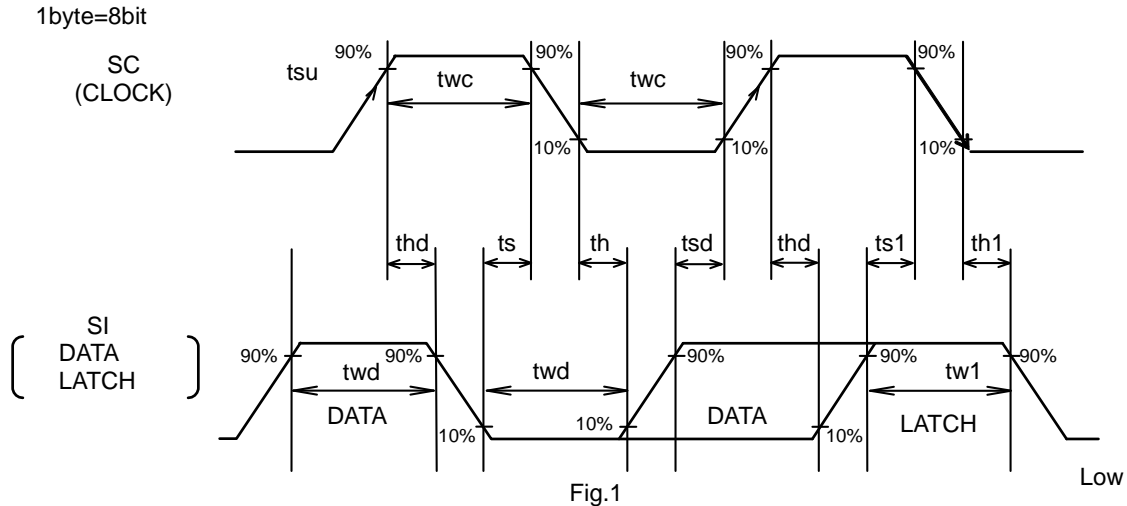

Parameter	Symbol	Limits			Unit
		Min.	Typ.	Max.	
Minimum Clock Width	twc	2.0	-	-	μs
Minimum Data Width	twd	2.0	-	-	μs
Minimum Latch Width	tw1	2.0	-	-	μs
Data Set-up Time (DATA→CLK)	Tsd	1.0	-	-	μs
Data Hold Time (CLK→DATA)	Thd	1.0	-	-	μs
Latch Set-up Time (CLK→LATCH)	ts1	1.0	-	-	μs
Latch Hold Time (DATA→LATCH)	th1	1.0	-	-	μs
Latch Low Set-up Time	ts	1.0	-	-	μs
Latch Low Hold Time	th	1.0	-	-	μs

2. Voltage Conditions for Control Signals (BD3403FV, BD3861FS)

Parameter	Condition	Limits			Unit
		Min.	Typ.	Max.	
“H” Input Voltage	V _{cc} =6.5 to 9.5V	2.6	-	5.5	V
“L” Input Voltage	V _{cc} =6.5 to 9.5V	0	-	1.1	V

3. Voltage Conditions for Control Signals (BD3883FS)

Parameter	Condition	Limits			Unit
		Min.	Typ.	Max.	
“H” Input Voltage	V _{cc} =6.5 to 9.5V	2.2	-	5.5	V
“L” Input Voltage	V _{cc} =6.5 to 9.5V	0	-	1.0	V

●Control data format list

(BD3403FV)

Address 1

D10	D11	D12	D13	D14	D15	D16	D17
OUTPUT Volume 1		OUTPUT Volume 2			Function Select 0 0		

Address 2

D20	D21	D22	D23	D24	D25	D26	D27
INPUT Volume				Surround 0:OFF 1:ON	Function Select 0 1 0		

Address 3

D30	D31	D32	D33	D34	D35	D36	D37
Input Selector			6dB SW 0: 0dB 1:+6dB	IN E MUTE 0:OFF 1:ON	Function Select 0 0 1		

Address 4

D40	D41	D42	D43	D44	D45	D46	D47
Input Gain/Bass				0: Input Gain 1: Bass	Function Select 1 0 1		

Address 5

D50	D51	D52	D53	D54	D55	D56	D57
Middle/Treble				0: Middle 1: Treble	Function Select 0 1 1		

(BD3861FS)

Address 1

D10	D11	D12	D13	D14	D15	D16	D17
OUTPUT Volume		OUTPUT Volume 2			Function Select 0 0		

Address 2

D20	D21	D22	D23	D24	D25	D26	D27
INPUT Volume					Function Select 0 1 0		

Address 3

D30	D31	D32	D33	D34	D35	D36	D37
Input Selector			6dBSW 0: 0dB 1:+6dB	IN E MUTE 0:OFF 1:ON	Function Select 0 0 1		

Address 4

D40	D41	D42	D43	D44	D45	D46	D47
Input Gain/Bass				0: Input Gain 1: Bass	Function Select 1 0 1		

Address 5

D50	D51	D52	D53	D54	D55	D56	D57
Middle/Treble				0: Middle 1: Treble	Function Select 0 1 1		

(BD3883FS)

- Basic Configuration of Control Data Format

← Data input direction

	MSB									LSB
	D9	D8	D7	D6	D5	D4	D3	D2	D1	D0
Data	Data								Select Address	

- Control Data Formats

← Data input direction

									Select Address	
	D9	D8	D7	D6	D5	D4	D3	D2	D1	D0
Data(1)	Input Gain			Input Selector			Treble fc		0	0
Data(2)	Front Volume A					Front Volume B		*	0	1
Data(3)	Bass Gain				Treble Gain				1	0
Data(4)	Middle Gain				Time Constant Select	REC OUT	Surround	Rear Volume	1	1

O* indicates 0 or 1.

- By changing the setting of Select Address, four different control formats are selectable. (BD3883FS)
- At power-on sequence, initialize all data.

Example:

← Data input direction

MSB	LSB	MSB	LSB	MSB	LSB	MSB	LSB
Data(1)	L	Data(2)	L	Data(3)	L	Data(4)	L

"L" means a "latch."

- After power-on, for the second and subsequent times, only the necessary data can be selected for setting.

Example: When changing the volume:

← Data input direction

MSB	LSB
Data(2)	L

"L" means a "latch."

- RECOUT, Surround and Rear Volume in Data(4) are Soft-switched using time constants. (BD3883FS)

●Block diagram, application circuit, pin assignment

(BD3403FV)

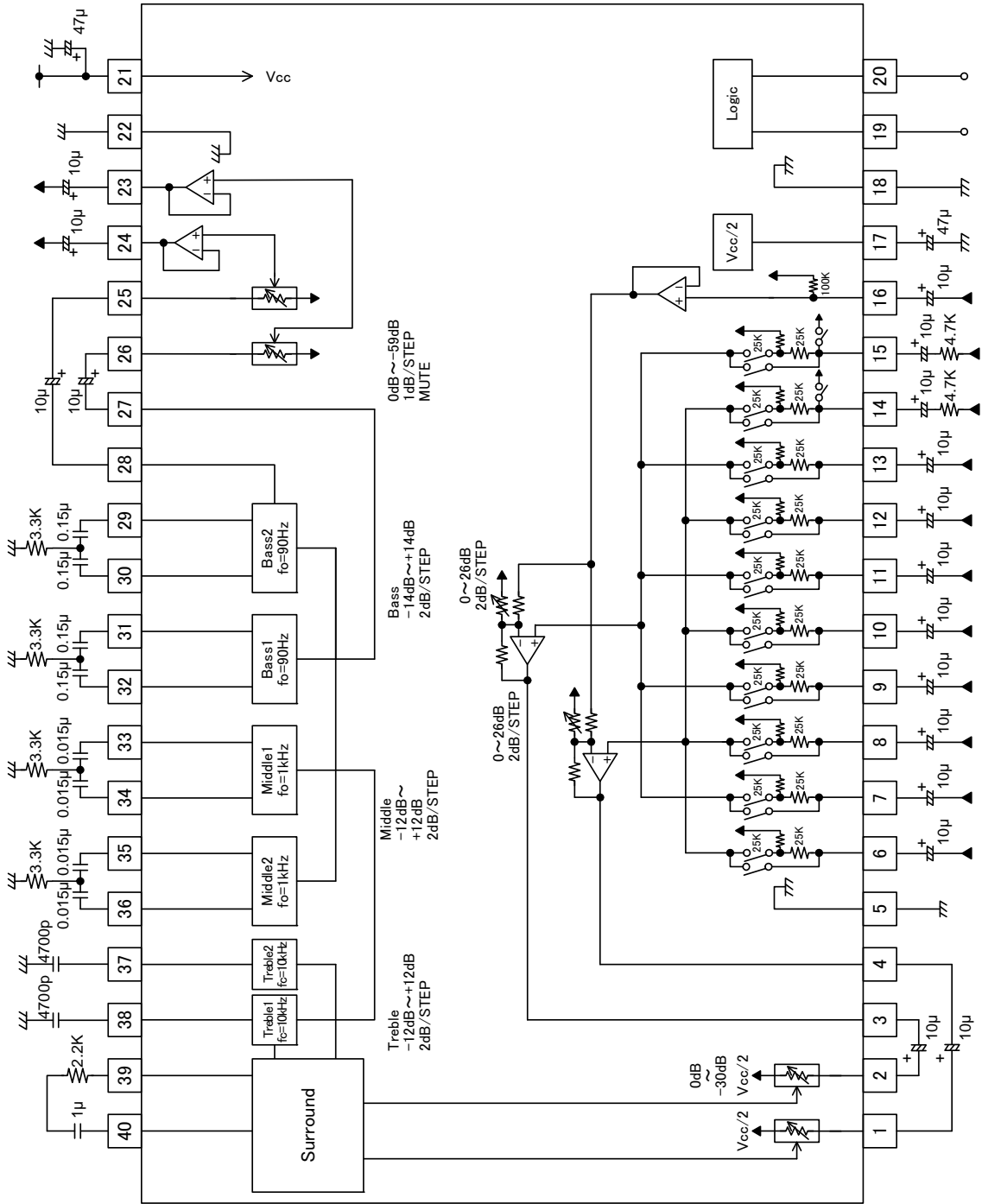

UNIT RESISTANCE : Ω
CAPACITANCE : F

Fig.2

(BD3861FS)

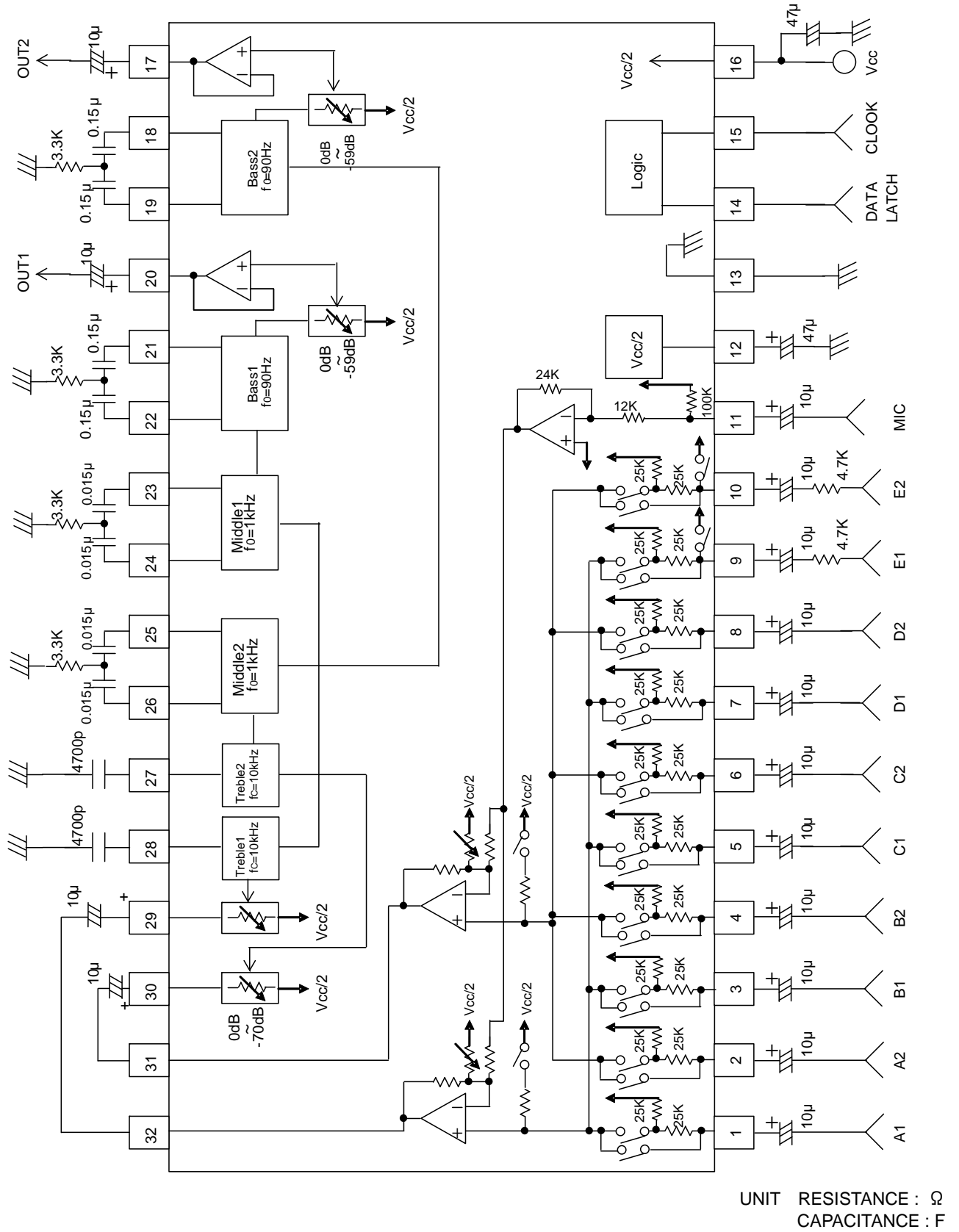

Fig.3

(BD3883FS)
When using RECOUT:

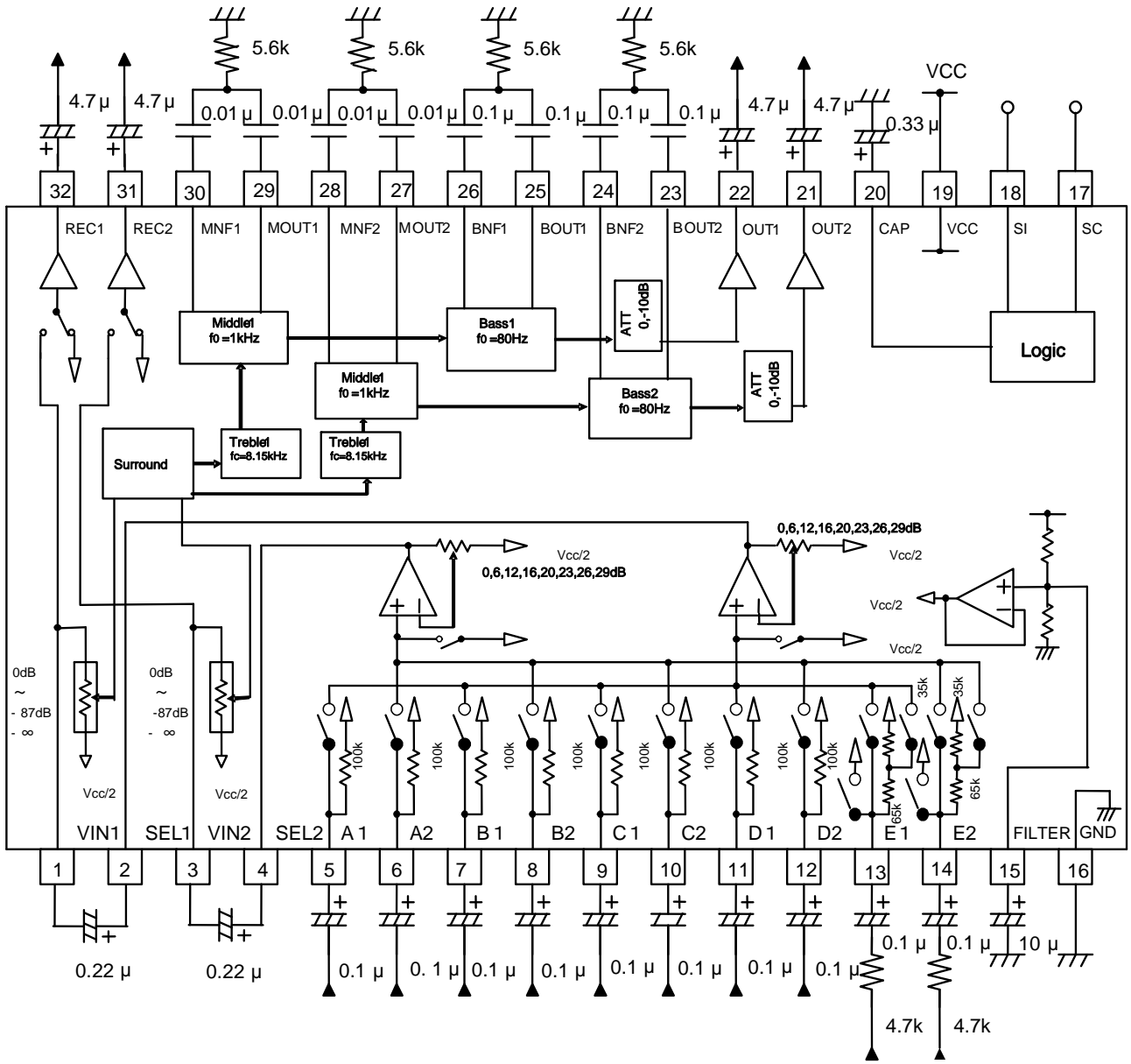
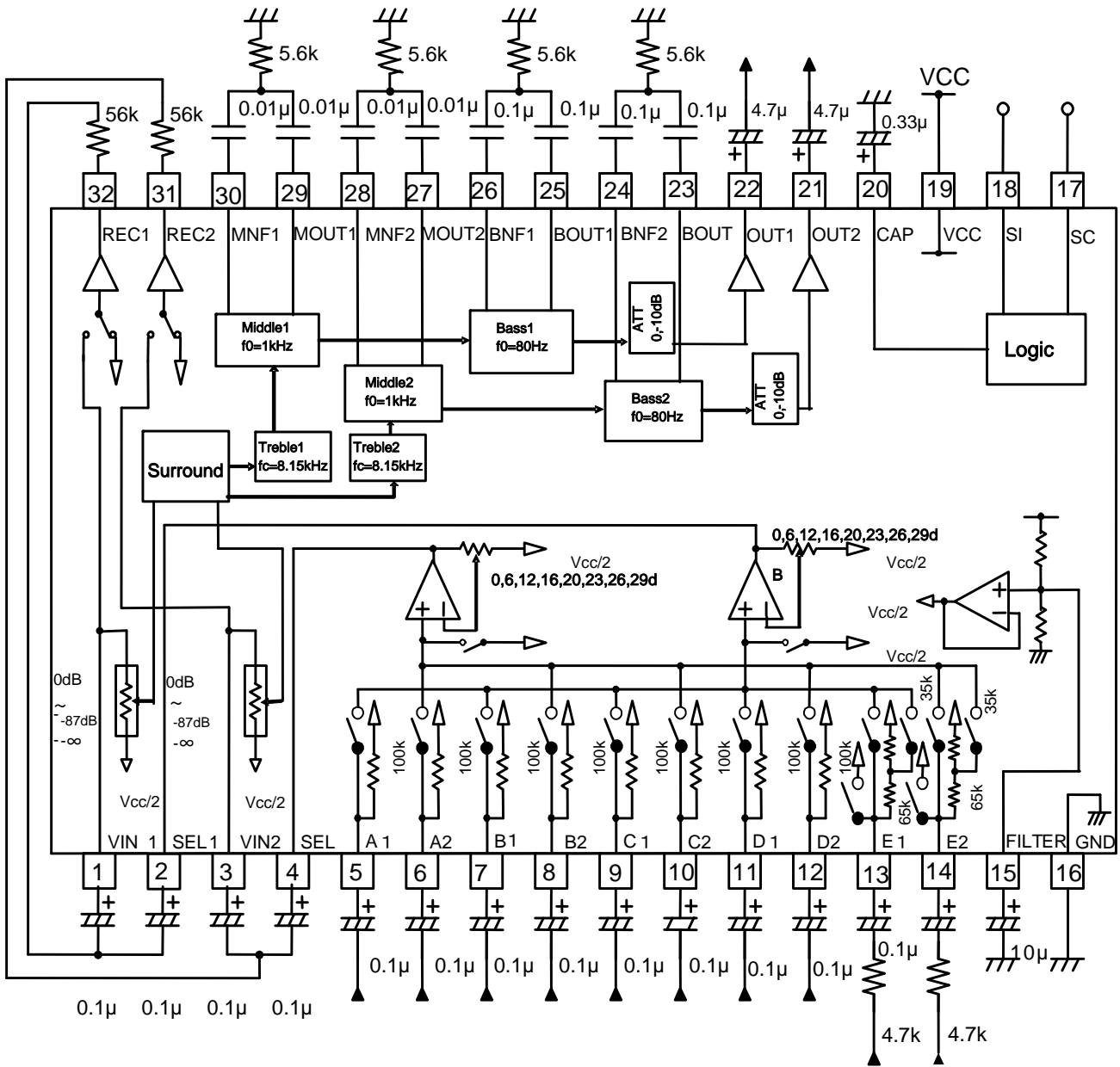

Fig.4

UNIT
RESISTANCE: Ω
CAPACITOR: F

(BD3883FS)
When using 2ndHPF:



UNIT
RESISTANCE:Ω
CAPACITOR:F

Fig.5

●Reference data

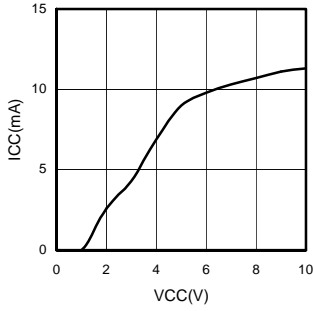

Fig.6 Circuit Current – Supply Voltage (BD3403FV)

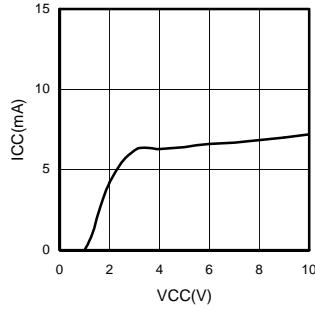

Fig.7 Circuit Current – Supply Voltage (BD3883FS)

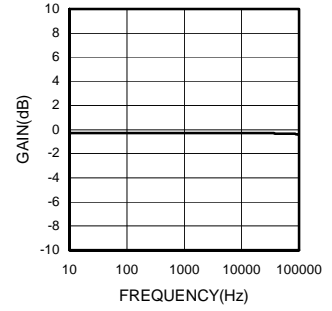

Fig.8 Voltage Gain - Frequency

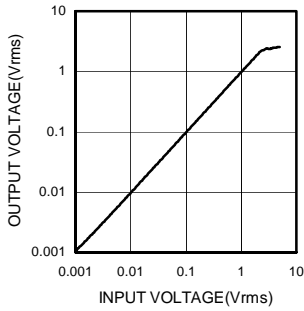

Fig.9 Output Voltage - Input Voltage

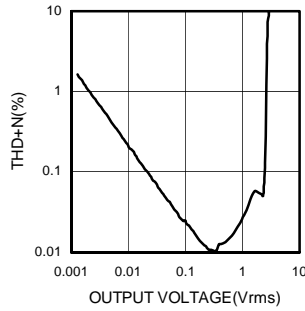

Fig.10 Total Harmonic Distortion ratio - Output Voltage (BD3403FV, BD3861FS)

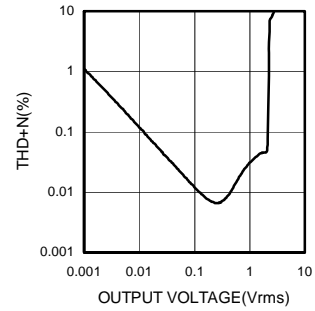

Fig.11 Total Harmonic Distortion ratio - Output Voltage (BD3883FS)

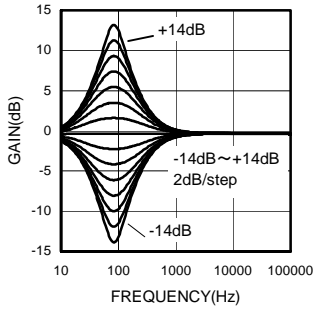

Fig.12 Bass Gain - Frequency (BD3403FV, BD3861FS)

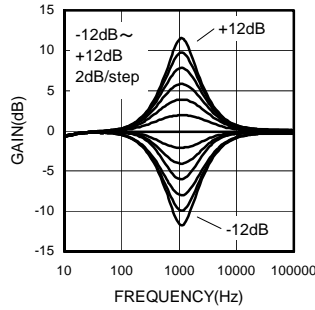

Fig.13 Middle Gain - Frequency (BD3403FV, BD3861FS)

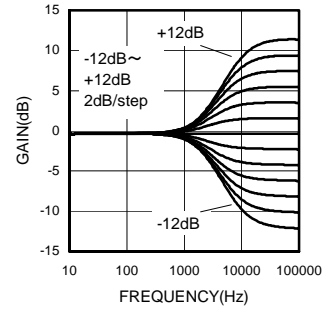

Fig.14 Treble Gain - Frequency (BD3403FV, BD3861FS)

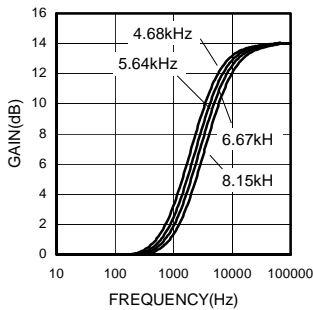

Fig.15 Variable Treble Cut-off Frequency (BD3883FS)

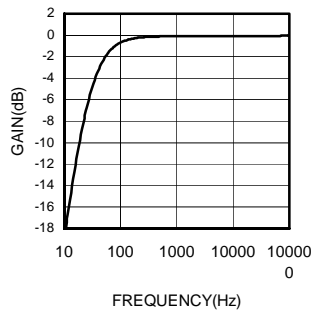

Fig.16 2ndHPF - Frequency (BD3883FS)

●Notes for use

- 1) Numbers and data in entries are representative design values and are not guaranteed values of the items.
- 2) Although ROHM is confident that the example application circuit reflects the best possible recommendations, be sure to verify circuit characteristics for your particular application. Modification of constants for other externally connected circuits may cause variations in both static and transient characteristics for external components as well as this Rohm IC. Allow for sufficient margins when determining circuit constants.
- 3) Absolute maximum ratings
Use of the IC in excess of absolute maximum ratings, such as the applied voltage or operating temperature range (Topr), may result in IC damage. Assumptions should not be made regarding the state of the IC (short mode or open mode) when such damage is suffered. A physical safety measure, such as a fuse, should be implemented when using the IC at times where the absolute maximum ratings may be exceeded.
- 4) GND potential
Ensure a minimum GND pin potential in all operating conditions. Make sure that no pins are at a voltage below the GND at any time, regardless of whether it is a transient signal or not.
- 5) Thermal design
Perform thermal design, in which there are adequate margins, by taking into account the permissible dissipation (Pd) in actual states of use.
- 6) Short circuit between terminals and erroneous mounting
Pay attention to the assembly direction of the ICs. Wrong mounting direction or shorts between terminals, GND, or other components on the circuits, can damage the IC.
- 7) Operation in strong electromagnetic field
Using the ICs in a strong electromagnetic field can cause operation malfunction.
- 8) 2-wire serial control
Because SC and SI terminals are designed for inputting high-frequency digital signals, wiring and layout patterns should be routed as not to cause interference with the analog-signal-related lines.
- 9) E Input external resistance (BD3883FS)
To avoid a sudden noise into E Input, external resistance (4.7kΩ) should be connected as close as possible to the IC terminal.
- 10) Function switching
Action to absorb shock sounds is taken when switching between the Volume, Treble, Middle and Bass functions.
- 11) Power-ON Reset (BD3883FS)
A built-in circuit for performing initialization inside the IC at Power-ON is provided. Specifically, the initial states are set as described in the table below. In the case of the setting design, however, to be on the safe side, it is recommended that data shall be sent to all the addresses as initial data at power-ON and, until this sending operation is completed, MUTE shall be applied. To avoid malfunctions, serial data signals must be set to the Low state at power-ON/OFF.

Function	Initial State
Input Selector	MUTE
Input Gain	0 dB
RECOU	OFF
Volume	-∞dB
Surround	OFF
Treble	0 dB
Middle	0 dB
Bass	0 dB
Rear Volume	0dB

- 12) Step switching noise (BD3883FS)
For Surround and Rear Volume, an external capacitor C is attached to the CAP pin to control the switching step noise. In the application circuit, a constant value, as an example, is shown by the CAP pin.
The time constant for charge/discharge of the capacitor C (varying between VBE to 5VBE (2.65V)) controls the slow switching operation.
The switching time constant T is calculated as the follows:

$$T=2.55 \times 10^5 \times C$$
VBE has temperature characteristics and may affect the value of the time constant T.

13) Input Selector and Input Gain

When changing Input Selector or Input Gain, the Soft-switching is not applied. Therefore, it is recommended to implement the MUTE function.

⊙MUTE setting example

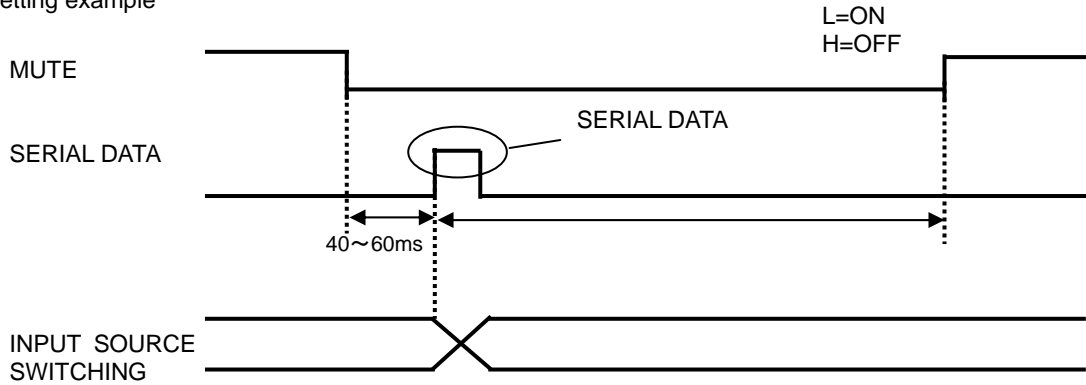

Fig.17

14) Constraints of serial control (BD3883FS)

On Soft-switching of the RECOUT, Surround, and Rear Volume functions, data must not be sent serially to the functions before the switching operation is completed.

If the function for Soft-switch should serially send the data (Data(4)) on the same Select Address, the time interval between the send operations must be set to 500 -600msec.

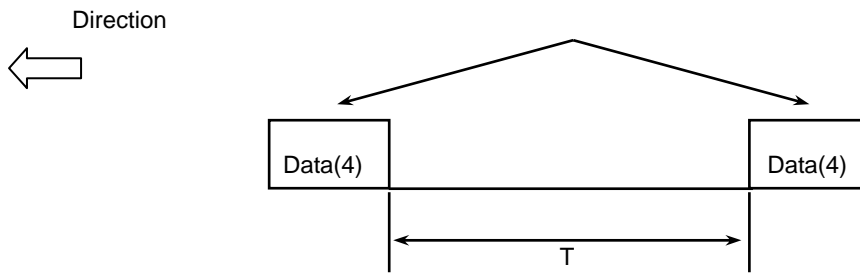

Fig.18

15) Function setting while muting Volume (BD3883FS)

While muting Volume, to avoid increasing residual noise, set Bass, Middle and Treble to 0dB, Surround to OFF, and Rear Volume to -10dB.

●Ordering part number

B	D
---	---

Part No.

3	4	0	3
---	---	---	---

Part No.
3403
3861,3883

F	V
---	---

Package
FV: SSOP-B40
FS: SSOP-A32

E	2
---	---

Packaging and forming specification
E2: Embossed tape and reel

SSOP-B40

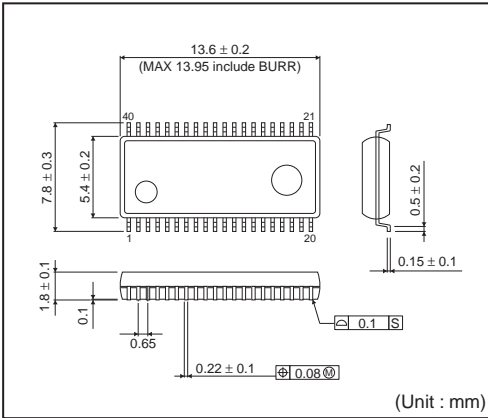

<Tape and Reel information>

Tape	Embossed carrier tape
Quantity	2000pcs
Direction of feed	E2 (The direction is the 1pin of product is at the upper left when you hold reel on the left hand and you pull out the tape on the right hand)

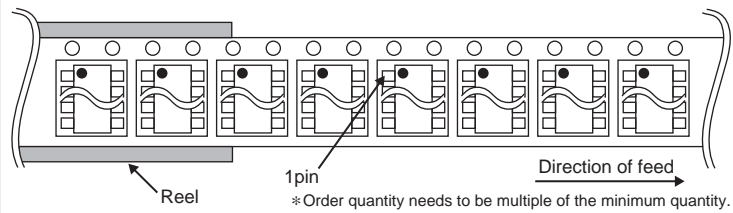

SSOP-A32

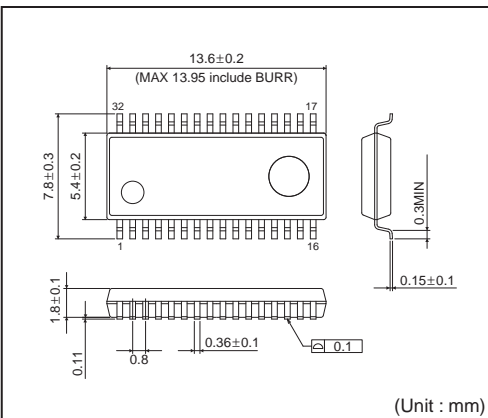

<Tape and Reel information>

Tape	Embossed carrier tape
Quantity	2000pcs
Direction of feed	E2 (The direction is the 1pin of product is at the upper left when you hold reel on the left hand and you pull out the tape on the right hand)

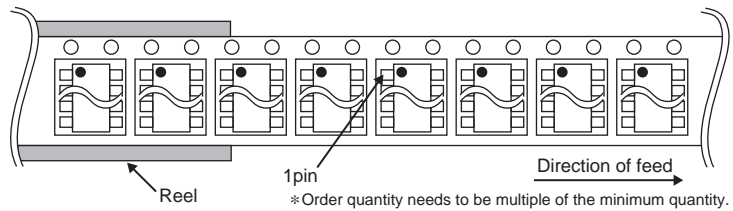

Notice

Precaution on using ROHM Products

- Our Products are designed and manufactured for application in ordinary electronic equipments (such as AV equipment, OA equipment, telecommunication equipment, home electronic appliances, amusement equipment, etc.). If you intend to use our Products in devices requiring extremely high reliability (such as medical equipment ^(Note 1), transport equipment, traffic equipment, aircraft/spacecraft, nuclear power controllers, fuel controllers, car equipment including car accessories, safety devices, etc.) and whose malfunction or failure may cause loss of human life, bodily injury or serious damage to property ("Specific Applications"), please consult with the ROHM sales representative in advance. Unless otherwise agreed in writing by ROHM in advance, ROHM shall not be in any way responsible or liable for any damages, expenses or losses incurred by you or third parties arising from the use of any ROHM's Products for Specific Applications.

(Note1) Medical Equipment Classification of the Specific Applications

JAPAN	USA	EU	CHINA
CLASS III	CLASS III	CLASS II b	CLASS III
CLASS IV		CLASS III	

- ROHM designs and manufactures its Products subject to strict quality control system. However, semiconductor products can fail or malfunction at a certain rate. Please be sure to implement, at your own responsibilities, adequate safety measures including but not limited to fail-safe design against the physical injury, damage to any property, which a failure or malfunction of our Products may cause. The following are examples of safety measures:
 - Installation of protection circuits or other protective devices to improve system safety
 - Installation of redundant circuits to reduce the impact of single or multiple circuit failure
- Our Products are designed and manufactured for use under standard conditions and not under any special or extraordinary environments or conditions, as exemplified below. Accordingly, ROHM shall not be in any way responsible or liable for any damages, expenses or losses arising from the use of any ROHM's Products under any special or extraordinary environments or conditions. If you intend to use our Products under any special or extraordinary environments or conditions (as exemplified below), your independent verification and confirmation of product performance, reliability, etc. prior to use, must be necessary:
 - Use of our Products in any types of liquid, including water, oils, chemicals, and organic solvents
 - Use of our Products outdoors or in places where the Products are exposed to direct sunlight or dust
 - Use of our Products in places where the Products are exposed to sea wind or corrosive gases, including Cl₂, H₂S, NH₃, SO₂, and NO₂
 - Use of our Products in places where the Products are exposed to static electricity or electromagnetic waves
 - Use of our Products in proximity to heat-producing components, plastic cords, or other flammable items
 - Sealing or coating our Products with resin or other coating materials
 - Use of our Products without cleaning residue of flux (even if you use no-clean type fluxes, cleaning residue of flux is recommended); or Washing our Products by using water or water-soluble cleaning agents for cleaning residue after soldering
 - Use of the Products in places subject to dew condensation
- The Products are not subject to radiation-proof design.
- Please verify and confirm characteristics of the final or mounted products in using the Products.
- In particular, if a transient load (a large amount of load applied in a short period of time, such as pulse. is applied, confirmation of performance characteristics after on-board mounting is strongly recommended. Avoid applying power exceeding normal rated power; exceeding the power rating under steady-state loading condition may negatively affect product performance and reliability.
- De-rate Power Dissipation (Pd) depending on Ambient temperature (Ta). When used in sealed area, confirm the actual ambient temperature.
- Confirm that operation temperature is within the specified range described in the product specification.
- ROHM shall not be in any way responsible or liable for failure induced under deviant condition from what is defined in this document.

Precaution for Mounting / Circuit board design

- When a highly active halogenous (chlorine, bromine, etc.) flux is used, the residue of flux may negatively affect product performance and reliability.
- In principle, the reflow soldering method must be used; if flow soldering method is preferred, please consult with the ROHM representative in advance.

For details, please refer to ROHM Mounting specification

Precautions Regarding Application Examples and External Circuits

1. If change is made to the constant of an external circuit, please allow a sufficient margin considering variations of the characteristics of the Products and external components, including transient characteristics, as well as static characteristics.
2. You agree that application notes, reference designs, and associated data and information contained in this document are presented only as guidance for Products use. Therefore, in case you use such information, you are solely responsible for it and you must exercise your own independent verification and judgment in the use of such information contained in this document. ROHM shall not be in any way responsible or liable for any damages, expenses or losses incurred by you or third parties arising from the use of such information.

Precaution for Electrostatic

This Product is electrostatic sensitive product, which may be damaged due to electrostatic discharge. Please take proper caution in your manufacturing process and storage so that voltage exceeding the Products maximum rating will not be applied to Products. Please take special care under dry condition (e.g. Grounding of human body / equipment / solder iron, isolation from charged objects, setting of Ionizer, friction prevention and temperature / humidity control).

Precaution for Storage / Transportation

1. Product performance and soldered connections may deteriorate if the Products are stored in the places where:
 - [a] the Products are exposed to sea winds or corrosive gases, including Cl₂, H₂S, NH₃, SO₂, and NO₂
 - [b] the temperature or humidity exceeds those recommended by ROHM
 - [c] the Products are exposed to direct sunshine or condensation
 - [d] the Products are exposed to high Electrostatic
2. Even under ROHM recommended storage condition, solderability of products out of recommended storage time period may be degraded. It is strongly recommended to confirm solderability before using Products of which storage time is exceeding the recommended storage time period.
3. Store / transport cartons in the correct direction, which is indicated on a carton with a symbol. Otherwise bent leads may occur due to excessive stress applied when dropping of a carton.
4. Use Products within the specified time after opening a humidity barrier bag. Baking is required before using Products of which storage time is exceeding the recommended storage time period.

Precaution for Product Label

QR code printed on ROHM Products label is for ROHM's internal use only.

Precaution for Disposition

When disposing Products please dispose them properly using an authorized industry waste company.

Precaution for Foreign Exchange and Foreign Trade act

Since our Products might fall under controlled goods prescribed by the applicable foreign exchange and foreign trade act, please consult with ROHM representative in case of export.

Precaution Regarding Intellectual Property Rights

1. All information and data including but not limited to application example contained in this document is for reference only. ROHM does not warrant that foregoing information or data will not infringe any intellectual property rights or any other rights of any third party regarding such information or data. ROHM shall not be in any way responsible or liable for infringement of any intellectual property rights or other damages arising from use of such information or data.:
2. No license, expressly or implied, is granted hereby under any intellectual property rights or other rights of ROHM or any third parties with respect to the information contained in this document.

Other Precaution

1. This document may not be reprinted or reproduced, in whole or in part, without prior written consent of ROHM.
2. The Products may not be disassembled, converted, modified, reproduced or otherwise changed without prior written consent of ROHM.
3. In no event shall you use in any way whatsoever the Products and the related technical information contained in the Products or this document for any military purposes, including but not limited to, the development of mass-destruction weapons.
4. The proper names of companies or products described in this document are trademarks or registered trademarks of ROHM, its affiliated companies or third parties.

General Precaution

1. Before you use our Products, you are requested to carefully read this document and fully understand its contents. ROHM shall not be in any way responsible or liable for failure, malfunction or accident arising from the use of any ROHM's Products against warning, caution or note contained in this document.
2. All information contained in this document is current as of the issuing date and subject to change without any prior notice. Before purchasing or using ROHM's Products, please confirm the latest information with a ROHM sales representative.
3. The information contained in this document is provided on an "as is" basis and ROHM does not warrant that all information contained in this document is accurate and/or error-free. ROHM shall not be in any way responsible or liable for any damages, expenses or losses incurred by you or third parties resulting from inaccuracy or errors of or concerning such information.

Компания «Life Electronics» занимается поставками электронных компонентов импортного и отечественного производства от производителей и со складов крупных дистрибьюторов Европы, Америки и Азии.

С конца 2013 года компания активно расширяет линейку поставок компонентов по направлению коаксиальный кабель, кварцевые генераторы и конденсаторы (керамические, пленочные, электролитические), за счёт заключения дистрибьюторских договоров

Мы предлагаем:

- Конкурентоспособные цены и скидки постоянным клиентам.
- Специальные условия для постоянных клиентов.
- Подбор аналогов.
- Поставку компонентов в любых объемах, удовлетворяющих вашим потребностям.
- Приемлемые сроки поставки, возможна ускоренная поставка.
- Доставку товара в любую точку России и стран СНГ.
- Комплексную поставку.
- Работу по проектам и поставку образцов.
- Формирование склада под заказчика.
- Сертификаты соответствия на поставляемую продукцию (по желанию клиента).
- Тестирование поставляемой продукции.
- Поставку компонентов, требующих военную и космическую приемку.
- Входной контроль качества.
- Наличие сертификата ISO.

В составе нашей компании организован Конструкторский отдел, призванный помогать разработчикам, и инженерам.

Конструкторский отдел помогает осуществить:

- Регистрацию проекта у производителя компонентов.
- Техническую поддержку проекта.
- Защиту от снятия компонента с производства.
- Оценку стоимости проекта по компонентам.
- Изготовление тестовой платы монтаж и пусконаладочные работы.



Тел: +7 (812) 336 43 04 (многоканальный)

Email: org@lifeelectronics.ru