

# Slotted Optical Flag Switch

OPB850A, OPB850-1Z



## Features:

- Snap into PCBoard mounting
- Transistor output
- Mechanical switch replacement
- Four 18" (457 mm) 26 AWG, UL wires for electrical connections
- Choice of phototransistor or Rbe phototransistor output

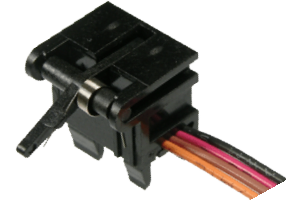

## Description:

Each **OPB850A** switch has a NPN phototransistor coupled with a 940 nm gallium arsenide infrared emitting diode in a molded plastic housing. Each **OPB850-1Z** has a Rbe phototransistor coupled with an 880 nm gallium arsenide infrared emitting diode in a molded plastic housing. An actuated lever arm flag interrupts the light beam, which switches the transistor output between states that can readily drive logic gates.

These devices are designed to replace conventional mechanical limit switches where long life and reliability are critical. The switches are designed to easily snap mount into a 0.036 inch (0.914 mm) 20 gage thick material with a rectangular opening of 0.315" x 0.472 " (8.0 mm x 12.0 mm).

Minor differences exist in the package between the **OPB850A** and **OPB850-1Z** (see drawings below). The cable exits the package in different locations.

Custom electrical, wire and cabling and connectors are available. Contact your local representative or OPTEK for more information.

## Applications:

- Non-contact interruptive object sensing
- Assembly line automation
- Machine automation
- Equipment security
- Machine safety

OPB850A, OPB850-1Z	
Pin # / Color	Description
1-Black	Emitter
2-Red	Anode
3-Brown	Collector
4-Orange	Cathode

Ordering Information		
Part Number	Wavelength	Description
<b>OPB850A</b>	940 nm	Slotted Optical Flag Switch 18" (457 mm) wires
<b>OPB850-1Z</b>	880 nm	Slotted Optical Flag Switch 18" (457 mm) wires

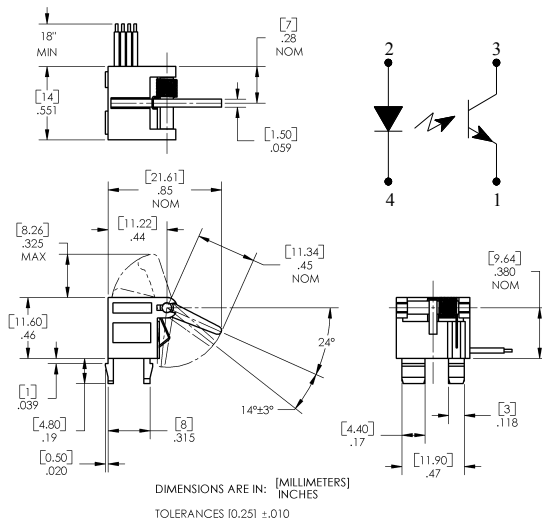

**OPB850A**

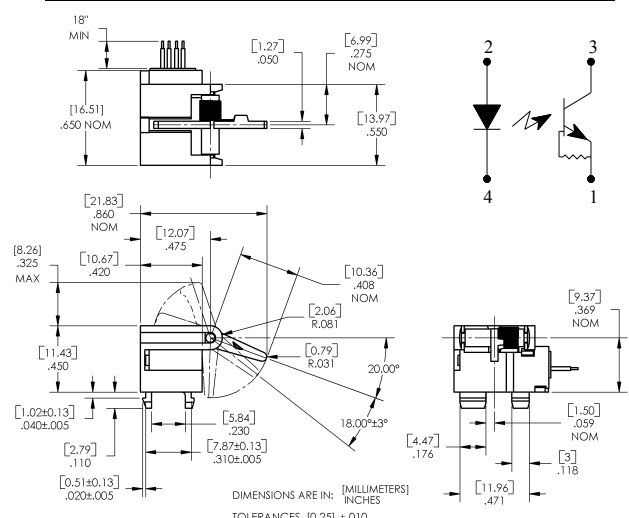

**OPB850-1Z**



## General Note

TT Electronics reserves the right to make changes in product specification without notice or liability. All information is subject to TT Electronics' own data and is considered accurate at time of going to print.

OPTEK Technology, Inc.  
1645 Wallace Drive, Carrollton, TX 75006 | Ph: +1 972 323 2200  
www.optekinc.com | www.ttelectronics.com

# Slotted Optical Flag Switch

OPB850A, OPB850-1Z



## Absolute Maximum Ratings ( $T_A = 25^\circ\text{C}$ unless otherwise noted)

Operating Temperature Range	-20° C to +75° C
Storage Temperature Range	-40° C to +85° C
Lead Soldering Temperature [1/16 inch (1.6 mm) from the case for 5 sec. with soldering iron]	260° C
<b>Input Diode</b>	
Reverse Voltage	5 V
Continuous Forward Current	50 mA
Peak Forward Current (10 $\mu\text{s}$ pulse width, 300 pps)	1 A
Power Dissipation	75 mW
<b>Output Phototransistor</b>	
Collector-Emitter Voltage	24 V
Emitter-Collector Voltage	5 V
Collector DC Current	20 mA
Power Dissipation	100 mW

General Note  
TT Electronics reserves the right to make changes in product specification without notice or liability. All information is subject to TT Electronics' own data and is considered accurate at time of going to print.

OPTEK Technology, Inc.  
1645 Wallace Drive, Carrollton, TX 75006 | Ph: +1 972 323 2200  
[www.optekinc.com](http://www.optekinc.com) | [www.ttelectronics.com](http://www.ttelectronics.com)

# Slotted Optical Flag Switch

OPB850A, OPB850-1Z



## Electrical Characteristics ( $T_A = 25^\circ\text{C}$ unless otherwise noted)

SYMBOL	PARAMETER	MIN	TYP	MAX	UNITS	TEST CONDITIONS
<b>Input Diode</b>						
$V_F$	Forward Voltage	-	1.2	1.6	V	$I_F = 20\text{ mA}$
$I_R$	Reverse Current	-	-	-	$\mu\text{A}$	$V_R = 2\text{ V}$
<b>Output Phototransistor (OPB850A)</b>						
$V_{(BR)CEO}$	Collector-Emitter Breakdown Voltage	30	-	-	V	$I_C = 100\ \mu\text{A}$ , $E_E = 0$
$V_{(BR)ECO}$	Emitter-Collector Breakdown Voltage	5	-	-	V	$I_E = 100\ \mu\text{A}$ , $E_E = 0$
$I_{CEO}$	Collector-Emitter Dark Current	-	-	100	nA	$V_{CE} = 10\text{ V}$ , $E_E = 0$
<b>Coupled (OPB850A)</b>						
$V_{CE(SAT)}$	Collector-Emitter Saturation Voltage <sup>(1)</sup>	-	-	0.4	V	$I_C = 250\ \mu\text{A}$ , $I_F = 20\text{ mA}$
$I_{C(ON)}$	On-State Collector Current <sup>(1)</sup>	0.5	2	-	mA	$V_{CE} = 5\text{ V}$ , $I_F = 20\text{ mA}$
$I_{C(OFF)}$	Off-State Collector Current <sup>(2)</sup>	-	-	10	$\mu\text{A}$	$V_{CE} = 5\text{ V}$ , $I_F = 20\text{ mA}$
<b>Output Phototransistor (OPB850-1Z)</b>						
$V_{(BR)CEO}$	Collector-Emitter Breakdown Voltage	24	-	-	V	$I_C = 100\ \mu\text{A}$ , $E_E = 0$
$V_{(BR)ECO}$	Emitter-Collector Breakdown Voltage	0.4	-	-	V	$I_E = 100\ \mu\text{A}$ , $E_E = 0$
$I_{CEO}$	Collector-Emitter Dark Current	-	-	100	nA	$V_{CE} = 10\text{ V}$ , $E_E = 0$
<b>Coupled (OPB850-1Z)</b>						
$V_{CE(SAT)}$	Collector-Emitter Saturation Voltage <sup>(1)</sup>	-	-	0.40	V	$I_C = 500\ \mu\text{A}$ , $I_F = 20\text{ mA}$
$I_{C(ON)}$	On-State Collector Current <sup>(1)</sup>	0.5	2	-	mA	$V_{CE} = 10\text{ V}$ , $I_F = 20\text{ mA}$
$I_{C(OFF)}$	Off-State Collector Current <sup>(2)</sup>	-	-	10	$\mu\text{A}$	$V_{CE} = 10\text{ V}$ , $I_F = 20\text{ mA}$

### Notes:

- (1) ON ( $I_{C(ON)}$ ) electrical condition corresponds to the switch point at about  $41^\circ$  angular displacement of the arm.
- (2) OFF ( $I_{C(OFF)}$ ) electrical condition corresponds to the mechanical arm position at rest.
- (3) From the rest position to the switch point, lever torque measured at the end of the arm is 1.5 grams maximum.
- (4) Wires are 26 AWG, UL rated.

Компания «Life Electronics» занимается поставками электронных компонентов импортного и отечественного производства от производителей и со складов крупных дистрибьюторов Европы, Америки и Азии.

С конца 2013 года компания активно расширяет линейку поставок компонентов по направлению коаксиальный кабель, кварцевые генераторы и конденсаторы (керамические, пленочные, электролитические), за счёт заключения дистрибьюторских договоров

Мы предлагаем:

- Конкурентоспособные цены и скидки постоянным клиентам.
- Специальные условия для постоянных клиентов.
- Подбор аналогов.
- Поставку компонентов в любых объемах, удовлетворяющих вашим потребностям.
- Приемлемые сроки поставки, возможна ускоренная поставка.
- Доставку товара в любую точку России и стран СНГ.
- Комплексную поставку.
- Работу по проектам и поставку образцов.
- Формирование склада под заказчика.
- Сертификаты соответствия на поставляемую продукцию (по желанию клиента).
- Тестирование поставляемой продукции.
- Поставку компонентов, требующих военную и космическую приемку.
- Входной контроль качества.
- Наличие сертификата ISO.

В составе нашей компании организован Конструкторский отдел, призванный помогать разработчикам, и инженерам.

Конструкторский отдел помогает осуществить:

- Регистрацию проекта у производителя компонентов.
- Техническую поддержку проекта.
- Защиту от снятия компонента с производства.
- Оценку стоимости проекта по компонентам.
- Изготовление тестовой платы монтаж и пусконаладочные работы.



Тел: +7 (812) 336 43 04 (многоканальный)

Email: [org@lifeelectronics.ru](mailto:org@lifeelectronics.ru)