



QPF4228

Wi-Fi Front End Module

Product Overview

The Qorvo® QPF4228 is an integrated front end module (FEM) designed for Wi-Fi 6 (802.11ax) systems. The compact form factor and integrated matching minimizes layout area in the application.

Performance is focused on optimizing the PA for a 3.3V supply voltage that conserves power consumption while maintaining the highest linear output power and leading edge throughput. Receive path matches the optimal technologies to maximize Rx sensitivity through noise figure performance that is consistent over a wider variety of conditions.

The receive path is pinned out so external filtering can be added in the optimal position. Integrated die level filtering for 2nd and 3rd harmonics as well as 5 GHz rejection for DBDC operation are included.

There are two options for power detect, a DC power detector which has voltage output and an RF power detector with an RF output from a directional coupler.

The QPF4228 integrates a 2.4GHz power amplifier (PA), regulator, single pole three throw switch (SP3T), low noise amplifier (LNA) and coupler into a single device

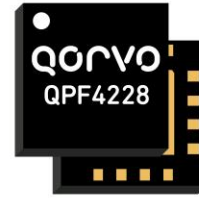

16 Pin 3x3 mm Laminate Package

Key Features

- 2412-2484 MHz
- P_{OUT} = +14dBm MCS11 HE40 -43dB Dynamic EVM
- P_{OUT} = +17dBm MCS9 VHT40 -35dB Dynamic EVM
- P_{OUT} = +18dBm MCS7 HT20/40 -30dB Dynamic EVM
- P_{OUT} = +21dBm MCS0 HT20 Spectral Mask Compliance
- Optimized for +3.3V Operation
- 0.5W Power Consumption at P_{OUT} = +17.5dBm
- 33dB Tx Gain
- 2.2dB Noise Figure
- 15dB Rx Gain & 7dB Bypass Loss
- 15dB 5GHz Rejection on Rx Path
- Integrated RF Power Detector Coupler as well as DC Power Detector

Functional Block Diagram

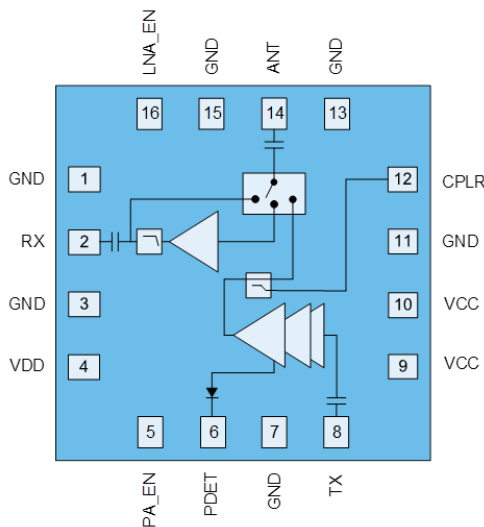

Top View

Applications

- Access Points
- Wireless Routers
- Client Equipment
- Customer Premise Equipment
- Internet of Things

Ordering Information

Part Number	Description
QPF4228SB	Sample bag with 5 pieces
QPF4228SQ	Sample bag with 25 pieces
QPF4228SR	7" reel with 100 pieces
QPF4228TR13-5K	13" reel with 5,000 pieces
QPF4228EVB-01	Assembled Evaluation Board

Handling Precautions

Parameter	Rating	Standard
ESD – Human Body Model (HBM)	Class 1C (1kV)	ANSI/ESDA/JEDEC JS-001
ESD – Charged Device Model (CDM)	Class C2b (750V)	ANSI/ESDA/JEDEC JS-002
MSL – Moisture Sensitivity Level	Level 3	IPC/JEDEC J-STD-020



Caution!

ESD sensitive device

Solderability

Compatible with both lead-free (260 °C max. reflow temperature) and tin/lead (245 °C max. reflow temperature) soldering processes.

Package lead plating: Electrolytic plated Au over Ni

RoHS Compliance

This part is compliant with the 2011/65/EU RoHS directive (Restrictions on the Use of Certain Hazardous Substances in Electrical and Electronic Equipment), as amended by Directive 2015/863/EU.

This product also has the following attributes:

- Product uses RoHS Exemption 7c-I to meet RoHS Compliance requirements
- Halogen Free (Chlorine, Bromine)
- Antimony Free
- TBBP-A (C₁₅H₁₂Br₄O₂) Free
- PFOS Free
- SVHC Free

Contact Information

For the latest specifications, additional product information, worldwide sales and distribution locations:

Web: www.qorvo.com

Tel: 1-844-890-8163

Email: customer.support@qorvo.com

Important Notice

The information contained herein is believed to be reliable; however, Qorvo makes no warranties regarding the information contained herein and assumes no responsibility or liability whatsoever for the use of the information contained herein. All information contained herein is subject to change without notice. Customers should obtain and verify the latest relevant information before placing orders for Qorvo products. The information contained herein or any use of such information does not grant, explicitly or implicitly, to any party any patent rights, licenses, or any other intellectual property rights, whether with regard to such information itself or anything described by such information. **THIS INFORMATION DOES NOT CONSTITUTE A WARRANTY WITH RESPECT TO THE PRODUCTS DESCRIBED HEREIN, AND QORVO HEREBY DISCLAIMS ANY AND ALL WARRANTIES WITH RESPECT TO SUCH PRODUCTS WHETHER EXPRESS OR IMPLIED BY LAW, COURSE OF DEALING, COURSE OF PERFORMANCE, USAGE OF TRADE OR OTHERWISE, INCLUDING THE IMPLIED WARRANTIES OF MERCHANTABILITY AND FITNESS FOR A PARTICULAR PURPOSE.**

Without limiting the generality of the foregoing, Qorvo products are not warranted or authorized for use as critical components in medical, life-saving, or life-sustaining applications, or other applications where a failure would reasonably be expected to cause severe personal injury or death.

Copyright 2018 © Qorvo, Inc. | Qorvo is a registered trademark of Qorvo, Inc.

Компания «Life Electronics» занимается поставками электронных компонентов импортного и отечественного производства от производителей и со складов крупных дистрибьюторов Европы, Америки и Азии.

С конца 2013 года компания активно расширяет линейку поставок компонентов по направлению коаксиальный кабель, кварцевые генераторы и конденсаторы (керамические, пленочные, электролитические), за счёт заключения дистрибьюторских договоров

Мы предлагаем:

- Конкурентоспособные цены и скидки постоянным клиентам.
- Специальные условия для постоянных клиентов.
- Подбор аналогов.
- Поставку компонентов в любых объемах, удовлетворяющих вашим потребностям.
- Приемлемые сроки поставки, возможна ускоренная поставка.
- Доставку товара в любую точку России и стран СНГ.
- Комплексную поставку.
- Работу по проектам и поставку образцов.
- Формирование склада под заказчика.
- Сертификаты соответствия на поставляемую продукцию (по желанию клиента).
- Тестирование поставляемой продукции.
- Поставку компонентов, требующих военную и космическую приемку.
- Входной контроль качества.
- Наличие сертификата ISO.

В составе нашей компании организован Конструкторский отдел, призванный помогать разработчикам, и инженерам.

Конструкторский отдел помогает осуществить:

- Регистрацию проекта у производителя компонентов.
- Техническую поддержку проекта.
- Защиту от снятия компонента с производства.
- Оценку стоимости проекта по компонентам.
- Изготовление тестовой платы монтаж и пусконаладочные работы.



Тел: +7 (812) 336 43 04 (многоканальный)

Email: org@lifeelectronics.ru