

VIDEO NOISE REDUCER

■ GENERAL DESCRIPTION

The NJM2224 is a video noise reducer IC of which operation is to reduce noise contained in video color and luminance signal, and at the same time to correct outline of horizontal and vertical image signal.

The NJM2224 is suited for VCR camera especially.

■ PACKAGE OUTLINE



NJM2224M

■ FEATURES

- Operating Voltage (+4.75V~+5.25V)
- Package Outline DMP8
- Bipolar Technology

■ RECOMMENDED OPERATING CONDITION

- Operating Voltage V+ 4.75~5.25V

■ PIN CONFIGURATION

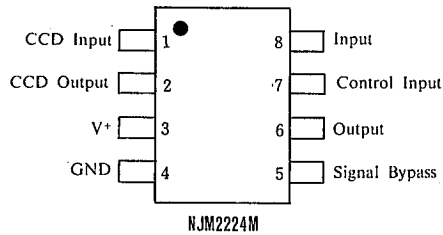

## ■ ABSOLUTE MAXIMUM RATINGS

(Ta=25°C)

PARAMETER	SYMBOL	RATINGS	UNIT
Supply Voltage	V*	8	V
Power Dissipation	P <sub>D</sub>	300	mW
Operating Temperature Range	T <sub>opr</sub>	-20~+75	°C
Storage Temperature Range	T <sub>stg</sub>	-40~+125	°C

## ■ ELECTRICAL CHARACTERISTICS

(V<sup>+</sup>=5V, f=100kHz, Ta=25°C)

PARAMETER	SYMBOL	TEST CONDITION	MIN.	TYP.	MAX.	UNIT
Operating Current	I <sub>CC</sub>		—	6.9	10	mA
Voltage Gain (Pin8-Pin2)	A <sub>U11</sub>	V <sub>7</sub> =4V, V <sub>IN</sub> =100mV <sub>p-p</sub>	-1	0	+1	dB
	A <sub>U12</sub>	V <sub>7</sub> =0V, V <sub>IN</sub> =100mV <sub>p-p</sub>	-11.5	-10	-8.5	
Voltage Gain (Pin1-Pin2)	A <sub>U21</sub>	V <sub>7</sub> =4V, V <sub>IN</sub> =100mV <sub>p-p</sub>	—	-45	-38	dB
	A <sub>U22</sub>	V <sub>7</sub> =0V, V <sub>IN</sub> =100mV <sub>p-p</sub>	-4.2	-3.2	-2.2	
Voltage Gain (Pin8-Pin6)	A <sub>U31</sub>	V <sub>7</sub> =4V, Pin2-1 (Inv. Amp), V <sub>IN</sub> =20mV <sub>p-p</sub>	—	—	-20	dB
	A <sub>U32</sub>	V <sub>7</sub> =4V, Pin2-1 (Inv. Amp), V <sub>IN</sub> =300mV <sub>p-p</sub>	-5	-3	-1	
Bandwidth (Pin8-Pin2)	f <sub>B1</sub>	V <sub>7</sub> =4V, V <sub>IN</sub> =100mV <sub>p-p</sub>	10	—	—	MHz
Bandwidth (pin1-pin2)	f <sub>B2</sub>	V <sub>7</sub> =0V, V <sub>IN</sub> =100mV <sub>p-p</sub>	10	—	—	MHz
Bandwidth (Pin8-Pin6)	f <sub>B3</sub>	V <sub>7</sub> =4V, V <sub>IN</sub> =100mV <sub>p-p</sub>	8	—	—	MHz
Pin6 DC Voltage	V <sub>6-DC</sub>		—	1.3	—	V

Note: Unless specified, all items are tested by Test Circuit.

## ■ TEST CIRCUIT

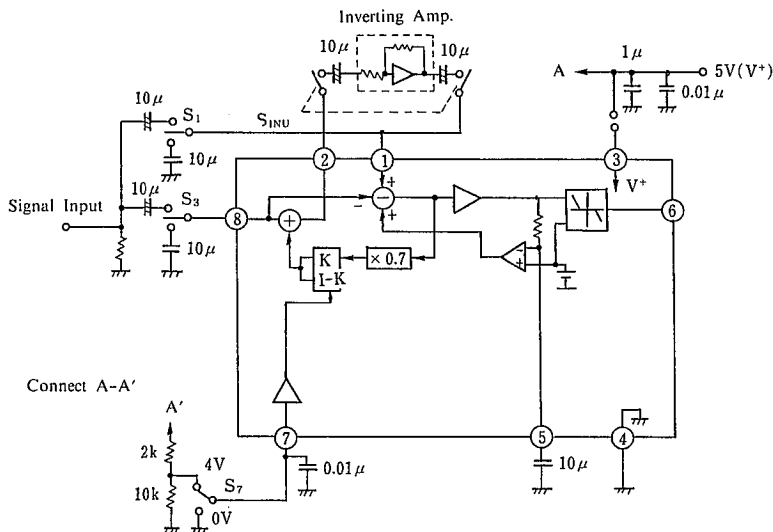

## ■ TERMINAL FUNCTION

PIN NO.	PIN NAME	INSIDE EQUIVALENT CIRCUITS	PIN NO.	PIN NAME	INSIDE EQUIVALENT CIRCUITS
1	CCD Input		5	Signal Bypass	
2	CCD Output		6	Output	
3	V+		7	Control Input	
4	GND		8	Input	

## ■ APPLICATION NOTE

The NJM2224 is an integrated circuit of composing variable comb type filter which reduces noise mixed in chroma or luminance signal of VCR camera and others. The CCD delay device is suitable for outside delay element composing comb type filter, compared with a glass delay device. The basic circuit is the most excellent FB system with NULL.

Fig.1 is its basic block diagram and Fig.2 is actual block diagram of NJM2224.

Fig.3 is one of application examples.

The video noise reducer system is composed of three capacitors for connection and one capacitor for signal bypass and CCD delay device. The NJM2224 is applicable to both of chroma and luminous signal using CCD delay device suitable for each signal. High level input to the Control of Reduce/Enhance terminal (Pin7) makes enhance mode (increasing of high frequency part) and Low level input makes reduce mode (decreasing of high frequency part.) Its threshold level is about 2.25V at 5V supply voltage. Basic operating characteristics is shown in Fig.4.

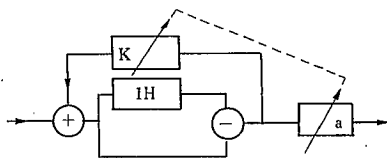

Fig. 1 Basic Block Diagram

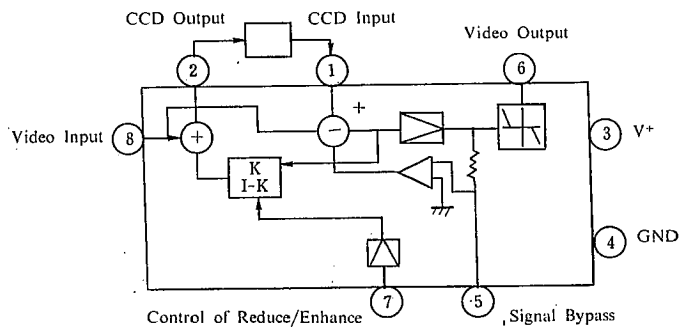

Fig. 2 Block Diagram

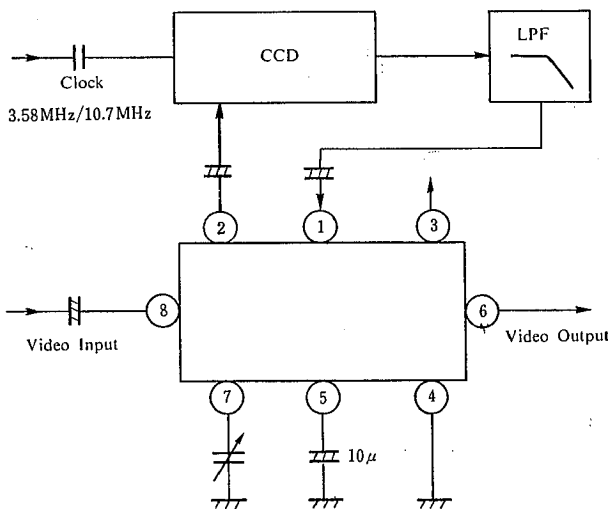

Fig. 3 Application

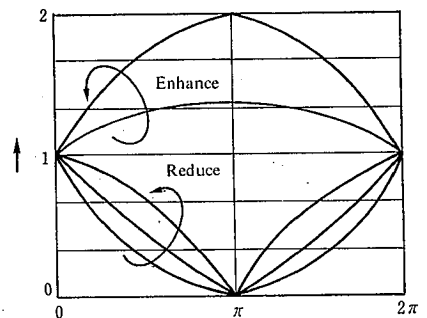

Fig. 4 Basic Operating Characteristic

The comb type filter has special frequency characteristics shown Fig.5, and is widely used to separate luminance and color signal in video-signal circuit. Using this comb type filter, the NJM2224 reduces noise and enhances signal in video signal, automatically.

Fig.6 shows video signal wave form and its frequency component.

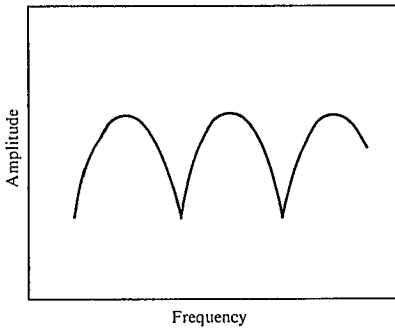

Fig. 5 Comb Type Filter Frequency Characteristic

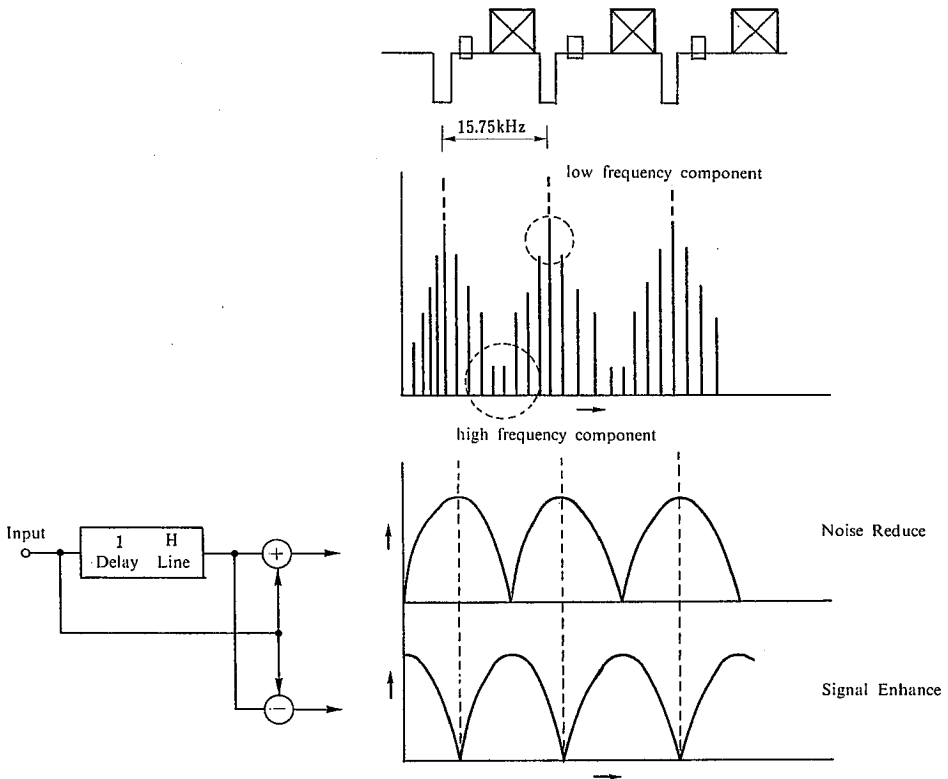
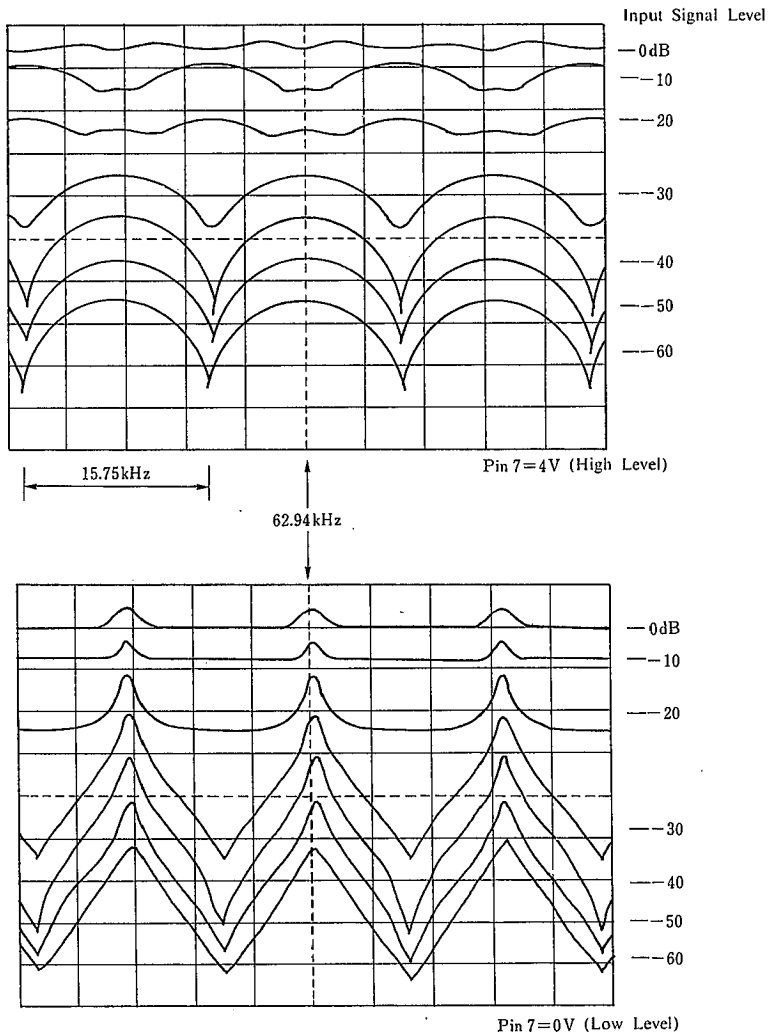

Fig. 6 Video Signal Waveform & Frequency Component

Fig.7 shows output characteristics determined by the input level to Pin7. The phase difference of each signal makes the output distortion of comb type filter characteristics, because FB system adds and subtracts each signal. The NJM2224 phase difference is 2 degree at 4MHz. High dynamic range of video signal is realized by high supply voltage.

Fig. 7 Comb Type Filter Characteristics vs. Input Signal Level (800mV<sub>p-p</sub>=0dB)



## MEMO

[CAUTION]

The specifications on this databook are only given for information, without any guarantee as regards either mistakes or omissions. The application circuits in this databook are described only to show representative usages of the product and not intended for the guarantee or permission of any right including the industrial rights.

Компания «Life Electronics» занимается поставками электронных компонентов импортного и отечественного производства от производителей и со складов крупных дистрибьюторов Европы, Америки и Азии.

С конца 2013 года компания активно расширяет линейку поставок компонентов по направлению коаксиальный кабель, кварцевые генераторы и конденсаторы (керамические, пленочные, электролитические), за счёт заключения дистрибьюторских договоров

Мы предлагаем:

- Конкурентоспособные цены и скидки постоянным клиентам.
- Специальные условия для постоянных клиентов.
- Подбор аналогов.
- Поставку компонентов в любых объемах, удовлетворяющих вашим потребностям.
- Приемлемые сроки поставки, возможна ускоренная поставка.
- Доставку товара в любую точку России и стран СНГ.
- Комплексную поставку.
- Работу по проектам и поставку образцов.
- Формирование склада под заказчика.
- Сертификаты соответствия на поставляемую продукцию (по желанию клиента).
- Тестирование поставляемой продукции.
- Поставку компонентов, требующих военную и космическую приемку.
- Входной контроль качества.
- Наличие сертификата ISO.

В составе нашей компании организован Конструкторский отдел, призванный помогать разработчикам, и инженерам.

Конструкторский отдел помогает осуществить:

- Регистрацию проекта у производителя компонентов.
- Техническую поддержку проекта.
- Защиту от снятия компонента с производства.
- Оценку стоимости проекта по компонентам.
- Изготовление тестовой платы монтаж и пусконаладочные работы.



Тел: +7 (812) 336 43 04 (многоканальный)  
Email: [org@lifeelectronics.ru](mailto:org@lifeelectronics.ru)