

TW8809

Low Cost Video Format Converter

FN8598

Rev 3.00

July 26, 2016

The [TW8809](#) is a low cost video format converter that can take either analog CVBS or 24-bit digital RGB format video and output these signals in ITU-R.656 format. The video sources can be scaled and deinterlaced, so that the ITU-R BT.656 output is already formatted to the desired resolution and in progressive format. In addition, the TW8809 has built-in OSD and image enhancement capabilities.

Applications

- Rear seat entertainment
- Radio head unit

Features

Analog Video Decoder

- NTSC (M, 4.43) and PAL (B, D, G, H, I, M, N, N combination), PAL (60), SECAM with automatic format detection
- Selectable differential or single-ended CVBS input
- Supports two differential or 4 single-ended CVBS inputs
- 10-bit ADC and analog clamping circuit
- Fully programmable static gain or automatic gain control for the Y or CVBS channel
- Programmable white peak control for the Y or CVBS channel
- High quality adaptive 2D comb filter for both NTSC and PAL inputs
- PAL delay line for color phase error correction
- Image enhancement with 2D dynamic peaking and CTI
- Digital subcarrier PLL for accurate color decoding
- Digital horizontal PLL and advanced synchronization processing for VCR playback and weak signal performance
- Programmable hue, brightness, saturation, contrast and sharpness

Digital Input

- Supports YCbCr/RGB 24-bit input
- Supports both BT.656 and BT.601 video formats
- Supports input resolutions up to 720p

Digital Output

- ITU-R BT.656 compatible YCbCr (4:2:2) output format
- Progressive ITU-R BT.656 output format for both interlaced and progressive inputs
- Output resolution up to SVGA (pseudo BT.656)

On Screen Display

- 256 font RAM and 512 display RAM
- Four windows font OSD with bordering/shadowing
- 1/2/3/4 bits/pixel
- Supports variable width (12/16), height (2~32)

Image Processing

- High quality scaler with both up/down and nonlinear scaling support
- Panorama/water-glass scaling
- Built-in 2D deinterlacing function
- Programmable hue, brightness, saturation, contrast and sharpness
- Programmable cropping of input video and graphics
- Independent RGB gain and offset controls
- Programmable 8-bit Gamma correction for each color
- Operates in frame sync mode
- Black/white stretch

Clock Generation

- Spread spectrum clock
- Selectable modulation frequency and spread width

Power Management

- Supports functional based independent power-down
- 1.8/3.3V operation

Miscellaneous

- Short-to-battery detection test
- Short-to-ground detection test
- Supports 2-wire serial bus interface
- Single 27MHz crystal
- 56 lead QFN (with wettable flanks)
- TW8809AT-NA2-GR is [AEC-Q100](#) qualified

TW8809 Functional Block Diagram

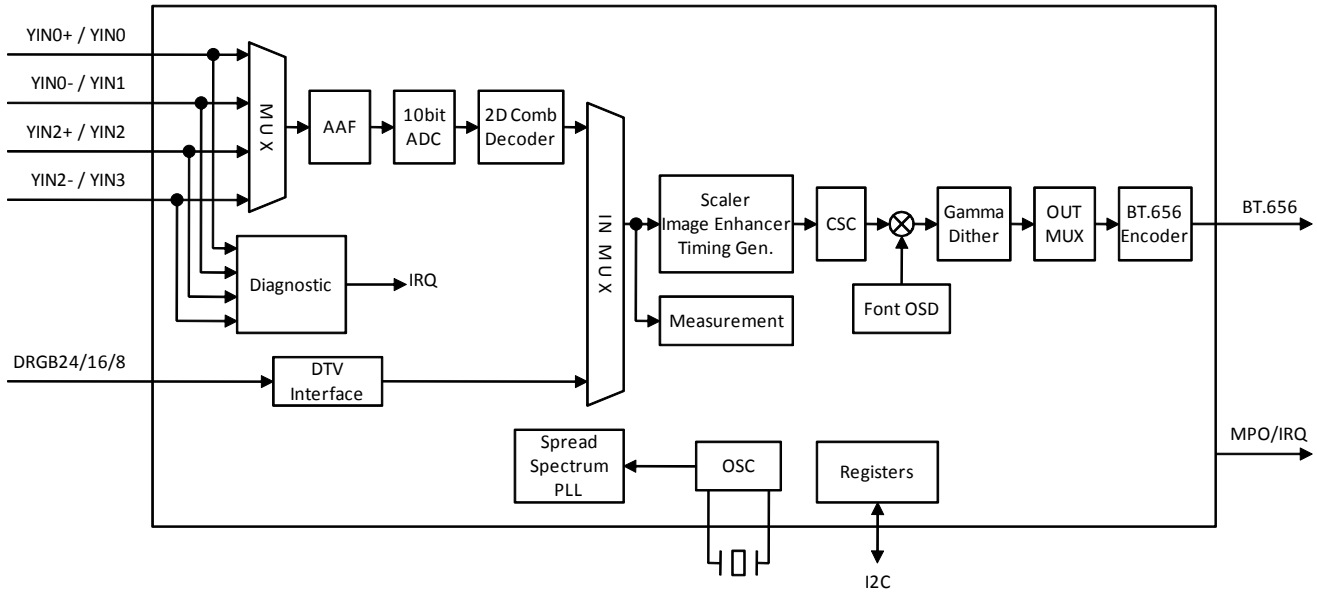

FIGURE 1. TW8809 FUNCTIONAL BLOCK DIAGRAM

© Copyright Intersil Americas LLC 2013-2016. All Rights Reserved.
 All trademarks and registered trademarks are the property of their respective owners.

For additional products, see www.intersil.com/en/products.html

Intersil products are manufactured, assembled and tested utilizing ISO9001 or TS16949 quality systems as applicable noted in the quality certifications found at www.intersil.com/en/support/qualandreliability.html

Intersil products are sold by description only. Intersil may modify the circuit design and/or specifications of products at any time without notice, provided that such modification does not, in Intersil's sole judgment, affect the form, fit or function of the product. Accordingly, the reader is cautioned to verify that datasheets are current before placing orders. Information furnished by Intersil is believed to be accurate and reliable. However, no responsibility is assumed by Intersil or its subsidiaries for its use; nor for any infringements of patents or other rights of third parties which may result from its use. No license is granted by implication or otherwise under any patent or patent rights of Intersil or its subsidiaries.

For information regarding Intersil Corporation and its products, see www.intersil.com

Компания «Life Electronics» занимается поставками электронных компонентов импортного и отечественного производства от производителей и со складов крупных дистрибьюторов Европы, Америки и Азии.

С конца 2013 года компания активно расширяет линейку поставок компонентов по направлению коаксиальный кабель, кварцевые генераторы и конденсаторы (керамические, пленочные, электролитические), за счёт заключения дистрибьюторских договоров

Мы предлагаем:

- Конкурентоспособные цены и скидки постоянным клиентам.
- Специальные условия для постоянных клиентов.
- Подбор аналогов.
- Поставку компонентов в любых объемах, удовлетворяющих вашим потребностям.
- Приемлемые сроки поставки, возможна ускоренная поставка.
- Доставку товара в любую точку России и стран СНГ.
- Комплексную поставку.
- Работу по проектам и поставку образцов.
- Формирование склада под заказчика.
- Сертификаты соответствия на поставляемую продукцию (по желанию клиента).
- Тестирование поставляемой продукции.
- Поставку компонентов, требующих военную и космическую приемку.
- Входной контроль качества.
- Наличие сертификата ISO.

В составе нашей компании организован Конструкторский отдел, призванный помогать разработчикам, и инженерам.

Конструкторский отдел помогает осуществить:

- Регистрацию проекта у производителя компонентов.
- Техническую поддержку проекта.
- Защиту от снятия компонента с производства.
- Оценку стоимости проекта по компонентам.
- Изготовление тестовой платы монтаж и пусконаладочные работы.



Тел: +7 (812) 336 43 04 (многоканальный)

Email: org@lifeelectronics.ru