



Features

- Lightweight, hand-held design
- Easy-to-read LCD display
- Simple operation
- High accuracy peak reading circuit
- Wide 10-1000 V test range
- Precise auto-sensing shutoff

Applications

Suitable for testing:

- Gas tubes
- Carbon gaps
- MOVs
- Zener and avalanche diodes
- Thyristor devices
- Finished product

BOURNS®

4010-01 - Surge Protector Test Set

Description

Bourns® 4010-01 Surge Protector Test Set is a hand-held, battery-operated tester designed to measure the clamping voltage and dc breakdown voltage of most surge protective devices. The 4010-01 is suitable for testing gas tubes, carbon gaps, MOVs, Zener and avalanche diodes and thyristor devices, both as components and as complete protectors.

The 4010-01 is a true slow-rise tester because it does not use a pulse transformer. It contains unique test circuitry and a precise 1mA detector. As soon as 1mA is conducted through clamping type devices, such as MOVs and avalanche diodes, the control circuits removes the test voltage from the output terminals and displays the clamping voltage on the meter. A low energy capacitive circuit will discharge through crowbar type protectors, such as gas tubes and carbon blocks, and trigger the detector. The breakdown voltage will be displayed and the test voltage removed.

Operation

Internal switches for ramp speed and discharge circuit type are accessed by removing the back cover. They are to be set for the intended application: 200 V/s for laboratory tests or QC type approvals; 1000 V/s for high-speed testing or sorting. The IEEE discharge circuit permits gas tubes to conduct in the arc mode, while the ITU circuit generally allows only glow currents to flow.

Pushing the test button applies a linear ramp to the device under test. Sensing circuitry automatically terminates the test when either the dc breakdown or 1mA clamping voltage is reached. The test value is maintained on the LCD display until the test button is released.

Specifications

Open Circuit Voltage Rate of Rise	200V/s or 1000 V/s
Maximum Output Voltage	1000 V
Useable Measuring Range	10-1000 V
Test Current for Clamping Devices	1 mA ±10 %
Test Current for Crowbar Devices	>1 A
Operating Temperature	0 to +50 °C
Storage Temperature	-10 to +60 °C
Measurement Accuracy	0.5 %
Power Source	3 lithium batteries - NEMA type 5024LC
Battery Life	
200 V/s	Up to 10,000 tests
1000 V/s	Up to 50,000 tests
Shipping Weight	2 lbs.
Warranty	2 years

Notes:

- For P-type thyristor protectors, breakdown voltage V_{BO} occurs at the device zener voltage V_Z . Therefore, the tester will measure actual V_{BO} .
- For N-type thyristor protectors, breakover voltage V_{BO} is higher than the zener voltage V_Z . For these devices, the tester will measure V_Z .

Functional Block Diagram

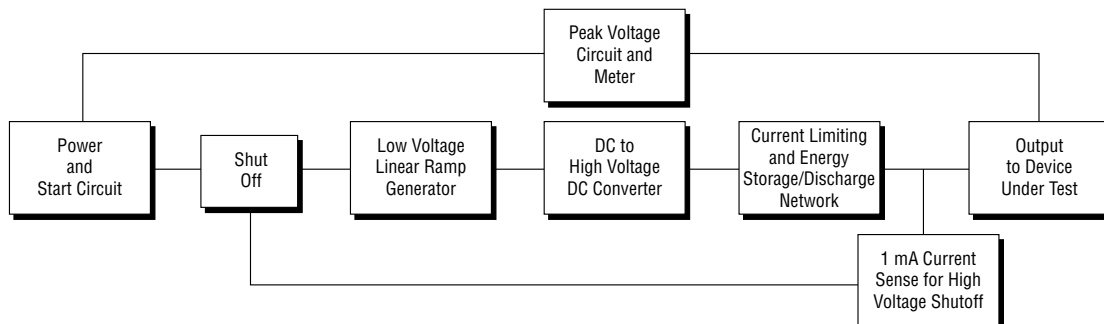

REV. D, 09/03

Specifications are subject to change without notice.
Customers should verify actual device performance in their specific applications.

Additional Features

- Selector switches for complete testing between all terminals and polarities
- Linear voltage ramp, selectable for 200 V/s or 1000 V/s operation
- Selectable IEEE or CCITT type discharge circuits
- Wide range of adapters for standard protector types

4010-01 - Surge Protector Test Set

BOURNS®

Product Dimensions

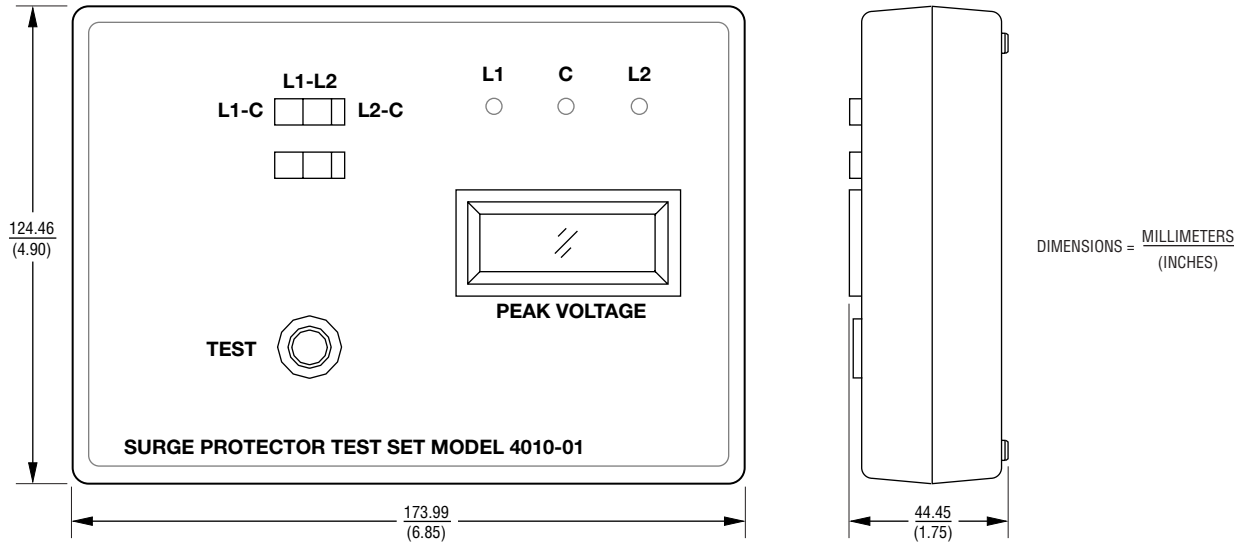

How To Order

Part No.	Accessories Included	Part No.	Available Separately
4010-01	No Accessories	30503-01	Test Cable w/Alligator Clip - Red
4010-01-A	Nylon Carrying Case	30503-02	Test Cable w/Alligator Clip - Black
4010-01-B	Nylon Case, 48-inch Leads w/Alligator Clips (Suitable for Testing A.C. Arresters on Site)	4020-00-A	A.C. Power Adapter
4010-01-C	Nylon Case, P/N 72288 and 72289 Gas Tube Adapters	72288	Adapter for 2-pole Gas Tubes, Fits 6 and 8 mm High Gas Tubes and Most Carbon Block Protectors
4010-01-D	Nylon Case, P/N 72291 5-Pin Module Adapter	72289	Adapter for 3-pole Gas Tubes with Leads on 4.4, 4.7 and 6.4 mm Centers
		72291	Adapter for Standard 300 Series 5-pin Protector Module

Компания «Life Electronics» занимается поставками электронных компонентов импортного и отечественного производства от производителей и со складов крупных дистрибьюторов Европы, Америки и Азии.

С конца 2013 года компания активно расширяет линейку поставок компонентов по направлению коаксиальный кабель, кварцевые генераторы и конденсаторы (керамические, пленочные, электролитические), за счёт заключения дистрибьюторских договоров

Мы предлагаем:

- Конкурентоспособные цены и скидки постоянным клиентам.
- Специальные условия для постоянных клиентов.
- Подбор аналогов.
- Поставку компонентов в любых объемах, удовлетворяющих вашим потребностям.
- Приемлемые сроки поставки, возможна ускоренная поставка.
- Доставку товара в любую точку России и стран СНГ.
- Комплексную поставку.
- Работу по проектам и поставку образцов.
- Формирование склада под заказчика.
- Сертификаты соответствия на поставляемую продукцию (по желанию клиента).
- Тестирование поставляемой продукции.
- Поставку компонентов, требующих военную и космическую приемку.
- Входной контроль качества.
- Наличие сертификата ISO.

В составе нашей компании организован Конструкторский отдел, призванный помогать разработчикам, и инженерам.

Конструкторский отдел помогает осуществить:

- Регистрацию проекта у производителя компонентов.
- Техническую поддержку проекта.
- Защиту от снятия компонента с производства.
- Оценку стоимости проекта по компонентам.
- Изготовление тестовой платы монтаж и пусконаладочные работы.



Тел: +7 (812) 336 43 04 (многоканальный)

Email: org@lifeelectronics.ru