

Optically Coupled Isolator

OPI120, OPI123



Features:

- 15 kV dc electrical isolation
- Choice of phototransistor or photodarlington output
- Hermetically sealed LED and photosensor
- Base contact for conventional transistor biasing (OP120 only)
- UL recognized File No. E58730
- Wide operating temperature range

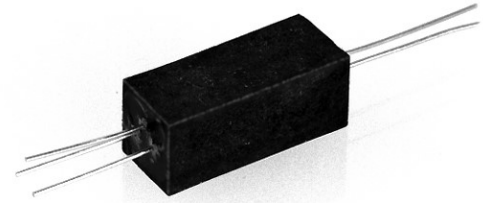

Description:

Each Optoisolator in this data sheet contains an infrared Light Emitting Diode (LED) and a NPN silicon Photosensor. The **OPI120** has an 890 nm Light Emitting Diode (LED) and NPN phototransistor sensor, whereas the **OP123** has a 890 nm LED and a photodarlington sensor. The devices are sealed in a precast opaque housing with a optically transmissive path between the LED and the photosensor.

The Optoisolators in this data sheet are UL recognized under UL file E58730.

This series is designed for transmission of information between one power supply voltage to another where the potentials during surge conditions are not greater than the guaranteed isolation voltage.

Custom electrical, wire and cabling and connectors are available. Contact your local representative or OPTEK for more information.

TX and TXV processing is available. For more information, contact your local representative or OPTEK.

Applications:

- High voltage isolation between input and output
- Electrical isolation in dirty environments
- Industrial equipment
- Medical equipment
- Office equipment

Ordering Information							
Part Number	LED Peak Wavelength	Sensor	Isolation Voltage (.000)	CTR Min	I _F (mA) Typ / Max	V _{CE} (Volts) Max	Lead Length / Spacing
OPI120	890 nm	Transistor	15	20	10 / 50	25	0.40" / 0.75"
OPI123	or 935 nm	Darlington		50		20	



RoHS

General Note

TT Electronics reserves the right to make changes in product specification without notice or liability. All information is subject to TT Electronics' own data and is considered accurate at time of going to print.

TT Electronics | OPTEK Technology, Inc.
1645 Wallace Drive, Carrollton, TX 75006 | Ph: +1 972 323 2200
sensors@ttelelectronics.com | www.ttelelectronics.com

Optically Coupled Isolator

OPI120, OPI123



Absolute Maximum Ratings (T_A = 25° C unless otherwise noted)

Storage Temperature	-55° C to +125° C
Operating Temperature	-55° C to +100° C
Input-to-Output Isolation Voltage ⁽¹⁾	± 15 kVDC
Lead Soldering Temperature (1/16" (1.6 mm) from case for 5 seconds with soldering iron) ⁽²⁾	260° C
Input Diode	
Forward DC Current ⁽³⁾	150 mA
Reverse DC Voltage	3 V
Power Dissipation ⁽⁴⁾	200 mW
Output Photosensor	
Collector-Emitter Voltage OPI120 OPI123	25 V 20 V
Emitter-Collector Voltage	5 V
Collector-Base Voltage OPI120	25 V
Power Dissipation ⁽⁵⁾	250 mW

Notes:

- (1) Measured with input and output leads shorted in air with a maximum relative humidity of 50%. UL recognition is for 15kV dc for one minute.
- (2) RMA flux is recommended. The duration can be extended to 10 seconds maximum when flow soldering.
- (3) Derate linearly 2.0 mA/°C above 25°C.
- (4) Derate linearly 2.67 mW/°C above 25°C.
- (5) Derate linearly 3.33 mW/°C above 25°C.

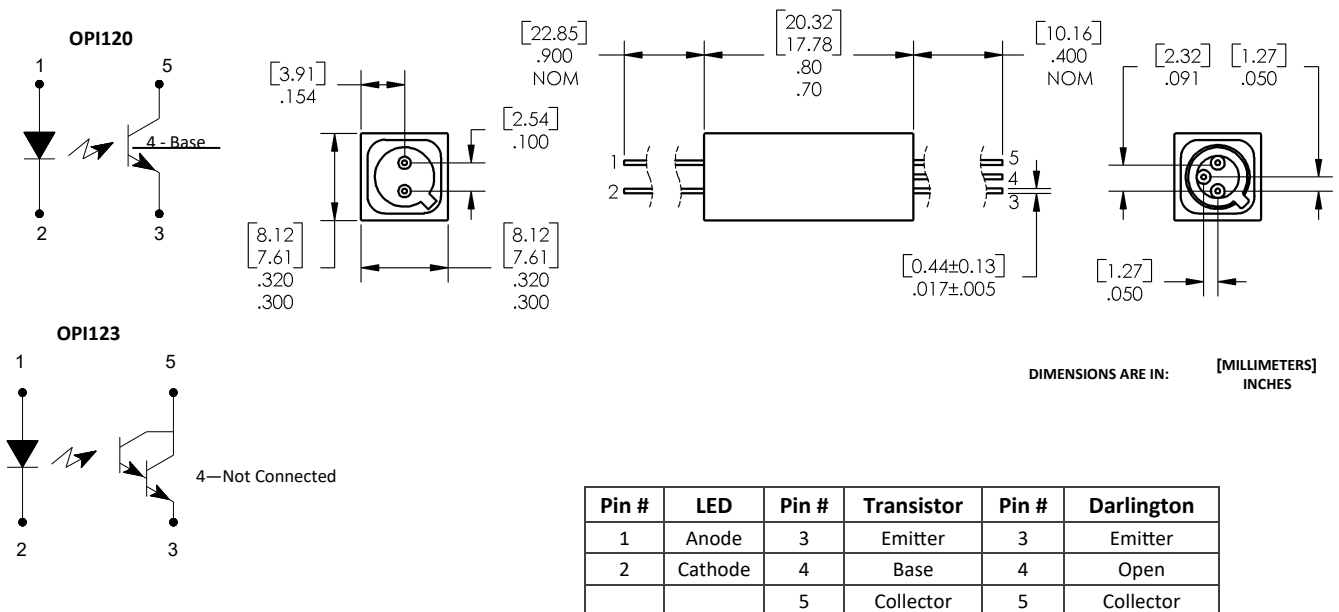

General Note

TT Electronics reserves the right to make changes in product specification without notice or liability. All information is subject to TT Electronics' own data and is considered accurate at time of going to print.

TT Electronics | OPTEK Technology, Inc.
1645 Wallace Drive, Carrollton, TX 75006 | Ph: +1 972 323 2200
sensors@ttelectronics.com | www.ttelectronics.com

Optically Coupled Isolator

OPI120, OPI123



Electrical Characteristics (-40° C to +85° C unless otherwise noted)

SYMBOL	PARAMETER	MIN	TYP	MAX	UNITS	TEST CONDITIONS
Input Diode						
V_F	Forward Voltage OPI120 OPI123	- -	- -	1.5 1.5	V	$I_F = 30 \text{ mA}$ $I_F = 10 \text{ mA}$
I_R	Reverse Current	-	-	100	μA	$V_R = 3 \text{ V}$
Output Photosensor (See OP236 for additional information - for reference only)						
$V_{(BR)CEO}$	Collector-Emitter Breakdown Voltage OPI120 OPI123	25 20	- -	- -	V	$I_C = 1 \text{ mA}$ $I_C = 1 \text{ mA}$
$V_{(BR)ECO}$	Emitter-Collector Breakdown Voltage	5	-	-	V	$I_E = 100 \mu\text{A}$
$V_{(BR)CBO}$	Collector-Base Breakdown Voltage OPI120	25	-	-	V	$I_C = 1 \text{ mA}$
I_{CEO}	Collector-Emitter Dark Current	-	-	100	nA	$V_{CE} = 10 \text{ V}$
Coupled (See OP804 and OP805 for additional information - for reference only)						
I_C/I_F	DC Current Transfer Ratio OPI120 OPI123	20 50	70 -	- -	%	$I_F = 10 \text{ mA}, V_{CE} = 5 \text{ V}$ $I_F = 10 \text{ mA}, V_{CE} = 2 \text{ V}$
$V_{CE(SAT)}$	Collector Saturation Voltage OPI120 OPI123	- -	- -	0.5 1.2	V	$I_F = 30 \text{ mA}, I_C = 1 \text{ mA}$ $I_F = 5 \text{ mA}, I_C = 1 \text{ mA}$
$I_{C(ON)}$	On Collector Current OPI120 OPI123	2.0 5.0	- -	50 -	mA	$I_F = 10 \text{ mA}, V_{CE} = 5 \text{ V}$ $I_F = 10 \text{ mA}, V_{CE} = 2 \text{ V}$
$I_{CB(ON)}$	On Collector Base Current—OPI120	15	-	-	μA	$I_F = 30 \text{ mA}, V_{CB} = 5 \text{ V}$
V_{ISO}	Isolation Voltage ⁽¹⁾	15	-	-	kV	See note 1
t_r, t_f	Output Rise Time, Output Fall Time OPI120 OPI123	- -	2 40	- -	μs	See Test Circuit

Notes:

(1) Measured with input and output leads shorted in air with a maximum relative humidity of 50%.

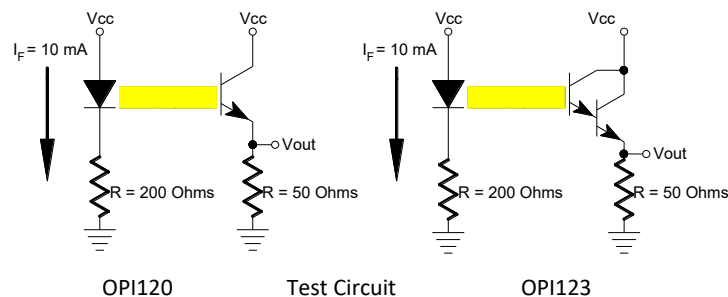

General Note

TT Electronics reserves the right to make changes in product specification without notice or liability. All information is subject to TT Electronics' own data and is considered accurate at time of going to print.

TT Electronics | OPTEK Technology, Inc.
1645 Wallace Drive, Carrollton, TX 75006 | Ph: +1 972 323 2200
sensors@ttelelectronics.com | www.ttelelectronics.com

Компания «Life Electronics» занимается поставками электронных компонентов импортного и отечественного производства от производителей и со складов крупных дистрибьюторов Европы, Америки и Азии.

С конца 2013 года компания активно расширяет линейку поставок компонентов по направлению коаксиальный кабель, кварцевые генераторы и конденсаторы (керамические, пленочные, электролитические), за счёт заключения дистрибьюторских договоров

Мы предлагаем:

- Конкурентоспособные цены и скидки постоянным клиентам.
- Специальные условия для постоянных клиентов.
- Подбор аналогов.
- Поставку компонентов в любых объемах, удовлетворяющих вашим потребностям.
- Приемлемые сроки поставки, возможна ускоренная поставка.
- Доставку товара в любую точку России и стран СНГ.
- Комплексную поставку.
- Работу по проектам и поставку образцов.
- Формирование склада под заказчика.
- Сертификаты соответствия на поставляемую продукцию (по желанию клиента).
- Тестирование поставляемой продукции.
- Поставку компонентов, требующих военную и космическую приемку.
- Входной контроль качества.
- Наличие сертификата ISO.

В составе нашей компании организован Конструкторский отдел, призванный помогать разработчикам, и инженерам.

Конструкторский отдел помогает осуществить:

- Регистрацию проекта у производителя компонентов.
- Техническую поддержку проекта.
- Защиту от снятия компонента с производства.
- Оценку стоимости проекта по компонентам.
- Изготовление тестовой платы монтаж и пусконаладочные работы.



Тел: +7 (812) 336 43 04 (многоканальный)

Email: org@lifeelectronics.ru