

DIMENSIONING AND TOLERANCING PER ASME Y14.5M (ISO STANDARDS)

REV	DESCRIPTION	DATE
D	REVISE PER ECO-13-13-002859	02/18/13

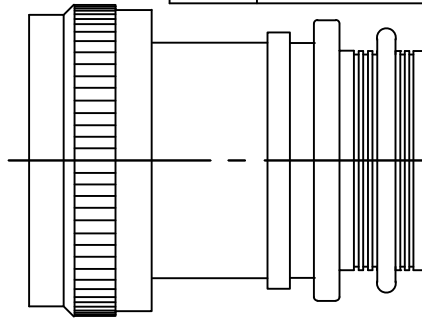

CODE 76 TINEL-LOCK ADAPTER

NOTES:

1. ALL DIMENSIONS ARE IN INCHES [MILLIMETERS].
2. SEE CH00-0250-008 FOR ORDERING INFORMATION, MODIFICATIONS, AND ADDITIONAL DIMENSIONS FOR MODIFICATIONS. MODIFICATIONS INDICATED BY TXR__M OR ANY OF THE FOLLOWING LETTERS AT THE END OF THE PART NUMBER H J L P T S N OR V.
3. SEE DRAWING TR FOR DETAIL ON TINEL-LOCK RING.
4. TEMPERATURE RANGE FOR ALUMINUM ALLOY:
-65 °C TO +150 °C.
5. ADAPTER TO BE PERMANENTLY MARKED WITH ASSEMBLY PN LESS RING DESIGNATOR (EG: TXR76AB00-1208) AND CODE IDENT. NO. (06090).
6. CONSULT FACTORY FOR OPTIONAL ENTRIES, MATERIALS, MODIFICATIONS, FINISHES AND BRAID DESIGNATORS.
7. INTERNAL EDGES SHALL BE ROUNDED.
8. FOR LARGER ENTRY SIZES, A 2 PIECE ADAPTER (TYPE II) IS SUPPLIED.
9. THIS PRODUCT IS DESIGNED TO TERMINATE A BRAIDED CABLE SHIELD AND A HEAT SHRINKABLE LIPPED BOOT TO A CONNECTOR.
10. RINGS SHALL BEAR NO MARKING.
11. ADAPTER MATES WITH BS 9522, N0001 PATT 603
BS 9522, F0017 PATT 105.

(C) 2008–2013 Tyco Electronics Corporation. All Rights Reserved

Raychem Adapters
CUSTOMER DRAWING

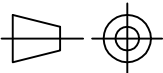
UNLESS OTHERWISE SPECIFIED DIMENSIONS ARE INCHES. METRIC DIMENSIONS ARE IN BRACKETS.	DRAWN A. BUI	DATE 08DEC08	 TE Connectivity	
	MATERIAL		TITLE	
DECIMAL TOLERANCES .XXX ± - [- mm] .XX ± - [- mm] .X ± - [- mm]	FINISH		TINEL-LOCK™ ADAPTER	
ANGLE TOLERANCE .X ± -	THIRD ANGLE PROJECTION 		SIZE A	CODE IDENT. NO. 06090
CAD FILE TXR76_C			DWG. NO. TXR76	REV
DO NOT SCALE THIS DRAWING			SHEET 1 OF 3 D	

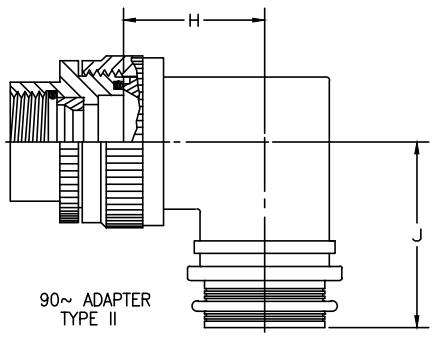
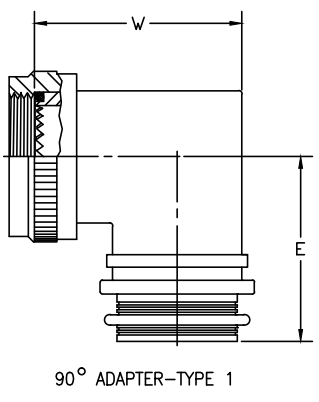
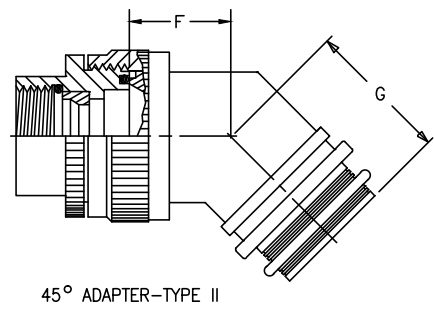
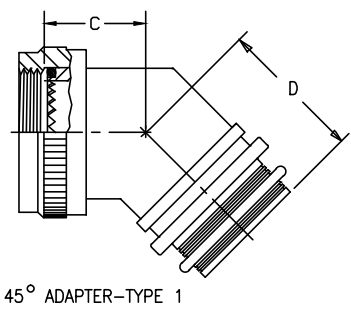
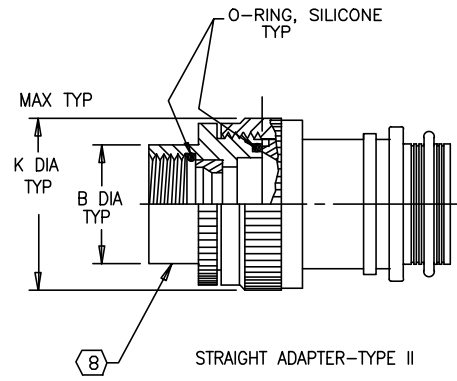
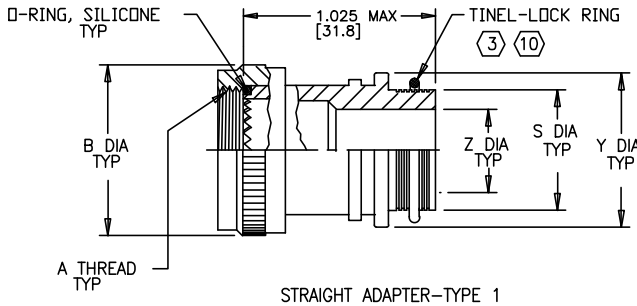

Raychem Adapters
CUSTOMER DRAWING

DRAWN A. BUI	DATE 08DEC08		SIZE A	CODE IDENT. NO. 06090	DWG. NO. TXR76	REV D
CAD FILE TXR76_D			DO NOT SCALE THIS DRAWING		SHEET 2 OF 3	

TABLE 1								
ORDER NO.	SHELL SIZE ⑪	MAX ENTRY SIZE TYPE I ⑧	A THREAD CLASS 2B	B DIA MAX	C MAX	D MAX	E MAX	W MAX
08	8	04	.438-28 UNEF	.79 [20.1]	.71 [18.0]	.84 [21.3]	1.05 [26.7]	.993 [25.2]
10	10	06	.562-24 UNEF	.91 [23.1]	.74 [18.8]	.87 [22.1]	1.11 [28.2]	1.056 [26.8]
12	12	08	.688-24 UNEF	1.07 [27.2]	.76 [19.3]	.90 [22.9]	1.19 [30.2]	1.181 [30.0]
14	14	10	.812-20 UNEF	1.19 [30.2]	.79 [20.1]	.92 [23.4]	1.25 [31.8]	1.306 [33.2]
16	16	12	.938-20 UNEF	1.32 [33.5]	.82 [20.8]	.95 [24.1]	1.32 [33.5]	1.431 [36.3]
18	18	14	1.062-18 UNEF	1.44 [36.6]	.84 [21.3]	.97 [24.6]	1.38 [35.1]	1.556 [39.5]
20	20	16	1.188-18 UNEF	1.57 [39.9]	.87 [22.1]	1.00 [25.4]	1.44 [36.6]	1.681 [42.7]
22	22	18	1.312-18 UNEF	1.69 [42.9]	.89 [22.6]	1.02 [25.9]	1.50 [38.1]	1.806 [45.9]
24	24	18	1.438-18 UNEF	1.79 [45.5]	.92 [23.4]	1.05 [26.7]	1.55 [39.4]	1.931 [49.0]

TABLE II								
ENTRY SIZE	Z +.010 -.020	S DIA	Y ±.015 [±0.38]	F MAX	G MAX	J MAX	H MAX	K MAX
04	.250 [6.35]	.376 [9.56] .370 [9.39]	.550 [13.97]	NA	NA	NA	NA	NA
05	.312 [7.92]	.438 [11.13] .432 [10.97]	.612 [15.54]	.77 [19.6]	.93 [23.6]	1.16 [29.5]	1.19 [30.2]	.80 [20.3]
06	.375 [9.52]	.501 [12.73] .495 [12.57]	.675 [17.14]	.77 [19.6]	.93 [23.6]	1.16 [29.5]	1.19 [30.2]	.80 [20.3]
07	.437 [11.09]	.563 [14.31] .556 [14.12]	.737 [18.71]	.80 [20.3]	.95 [24.1]	1.22 [31.0]	1.38 [35.1]	.92 [23.4]
08	.500 [12.70]	.626 [15.91] .619 [15.72]	.800 [20.32]	.80 [20.3]	.95 [24.1]	1.22 [31.0]	1.38 [35.1]	.92 [23.4]
10	.625 [15.87]	.752 [19.11] .742 [18.84]	.925 [23.49]	.84 [21.3]	1.00 [25.4]	1.35 [34.3]	1.51 [38.4]	1.18 [30.0]
12	.750 [19.05]	.877 [22.28] .867 [22.02]	1.050 [26.67]	.86 [21.8]	1.01 [25.7]	1.40 [35.6]	1.63 [41.4]	1.35 [34.3]
14	.875 [22.23]	1.002 [25.46] .991 [25.17]	1.175 [29.84]	.88 [22.4]	1.04 [26.4]	1.46 [37.1]	1.78 [45.2]	1.41 [35.8]
16	1.000 [25.40]	1.127 [28.63] 1.116 [28.34]	1.300 [33.02]	.91 [23.1]	1.06 [26.9]	1.53 [38.9]	1.88 [47.8]	1.60 [40.6]
18	1.125 [28.57]	1.252 [31.81] 1.241 [31.52]	1.425 [36.19]	.93 [23.6]	1.09 [27.7]	1.59 [40.4]	2.01 [51.1]	1.66 [42.2]
20	1.250 [31.75]	1.377 [34.98] 1.366 [34.69]	1.550 [39.37]	.98 [24.9]	1.13 [28.7]	1.78 [45.2]	2.13 [54.1]	2.04 [51.8]
22	1.375 [34.93]	1.502 [38.15] 1.488 [37.79]	1.675 [42.55]	1.03 [26.2]	1.38 [35.1]	1.85 [47.0]	2.29 [58.2]	2.23 [56.6]
24	1.500 [38.10]	1.627 [41.33] 1.613 [40.97]	1.800 [45.72]	1.08 [27.4]	1.44 [36.6]	1.92 [48.8]	2.42 [61.5]	2.23 [56.6]

Raychem Adapter
CUSTOMER DRAWING

DRAWN A. BUI	DATE 08DEC08		SIZE A	CODE IDENT. NO. 06090	DWG. NO. TXR76	REV D
CAD FILE TXR76_D			DO NOT SCALE THIS DRAWING		SHEET 3 OF 3	

Компания «Life Electronics» занимается поставками электронных компонентов импортного и отечественного производства от производителей и со складов крупных дистрибьюторов Европы, Америки и Азии.

С конца 2013 года компания активно расширяет линейку поставок компонентов по направлению коаксиальный кабель, кварцевые генераторы и конденсаторы (керамические, пленочные, электролитические), за счёт заключения дистрибьюторских договоров

Мы предлагаем:

- Конкурентоспособные цены и скидки постоянным клиентам.
- Специальные условия для постоянных клиентов.
- Подбор аналогов.
- Поставку компонентов в любых объемах, удовлетворяющих вашим потребностям.
- Приемлемые сроки поставки, возможна ускоренная поставка.
- Доставку товара в любую точку России и стран СНГ.
- Комплексную поставку.
- Работу по проектам и поставку образцов.
- Формирование склада под заказчика.
- Сертификаты соответствия на поставляемую продукцию (по желанию клиента).
- Тестирование поставляемой продукции.
- Поставку компонентов, требующих военную и космическую приемку.
- Входной контроль качества.
- Наличие сертификата ISO.

В составе нашей компании организован Конструкторский отдел, призванный помогать разработчикам, и инженерам.

Конструкторский отдел помогает осуществить:

- Регистрацию проекта у производителя компонентов.
- Техническую поддержку проекта.
- Защиту от снятия компонента с производства.
- Оценку стоимости проекта по компонентам.
- Изготовление тестовой платы монтаж и пусконаладочные работы.



Тел: +7 (812) 336 43 04 (многоканальный)

Email: org@lifeelectronics.ru