

Standard Blowers For HVAC Applications

Catalogue 02/2005



ebmpapst

AC centrifugal blowers

Dual inlet, sizes 097 to 250



Standard design, dual inlet forward curved blowers.

Material: scroll housing and impeller made of galvanised sheet steel.

Mounting: either SAL (standard external-rotor) motor mounted via brackets on one side of the scroll housing, or, EW-motor anti-vibration mounted on both sides.

Availability: all units available from stock.

Specification: all units supplied pre-wired into terminal block including motor start capacitors. all units supplied with outlet flange for easy mounting.

ebm-papst UK

Nominal data		Voltage	Frequency	Airflow	Speed/rpm	Power Input	Current Draw	Ingress Protection	Max. Ambient	Mass	Capacitor Size	Insulation Class	Min. back pressure	
Type	Motor	VAC	Hz	m ³ /h	Min ⁻¹	W	A	IP	°C	kg	uF	Ins.	Pa	
D2E097-BI56-50	M2E052CA	①	230	50/60	435	1950	87	0.39	IP20	40	1.5	2uF	B	0
D2E133-CI33-87	M2E068CF	②	230	50/60	700	1700	175	0.77	IP44	40	3.3	4uF	B	50
D2E133-DM27-D8	M2E068CF	③	230	50/60	925	1700	200	0.88	IP44	40	4.4	5uF	B	0
D4E133-AA01-57	M4E068BF	④	230	50/60	535	1170	66	0.29	IP44	40	2.6	2uF	B	0
D2E146-AP43-62	M2E068EC	⑤	230	50/60	935	1650	245	1.08	IP44	40	4.2	6uF	B	100
D2E146-AP47-75	M2E068EC	⑥	230	50/60	970	2050	300	1.31	IP44	40	4.2	8uF	B	200
D4E160-EG06-11	M4E068EC	⑦	230	50/60	1240	1300	180	0.79	IP44	40	4.6	5uF	B	0
D4E180-BA02-25	M4E068LA	⑧	230	50/60	1900	1250	360	1.58	IP54	40	11.0	10uF	B	0
D4E200-BA05-50	M4E068LA	⑨	230	50	2260	1060	420	1.8	IP54	40	11.9	8uF	B	0
D4E225-BC01-36	M4E074LA	⑩	230	50	2600	1100	700	3.05	IP22	40	12.1	25uF	B	0
D4E250-BA01-12	M4E094LA	⑪	230	50/60	3730	1210	1240	6.0	IP20	40	16.3	14uF	F	0

Characteristics

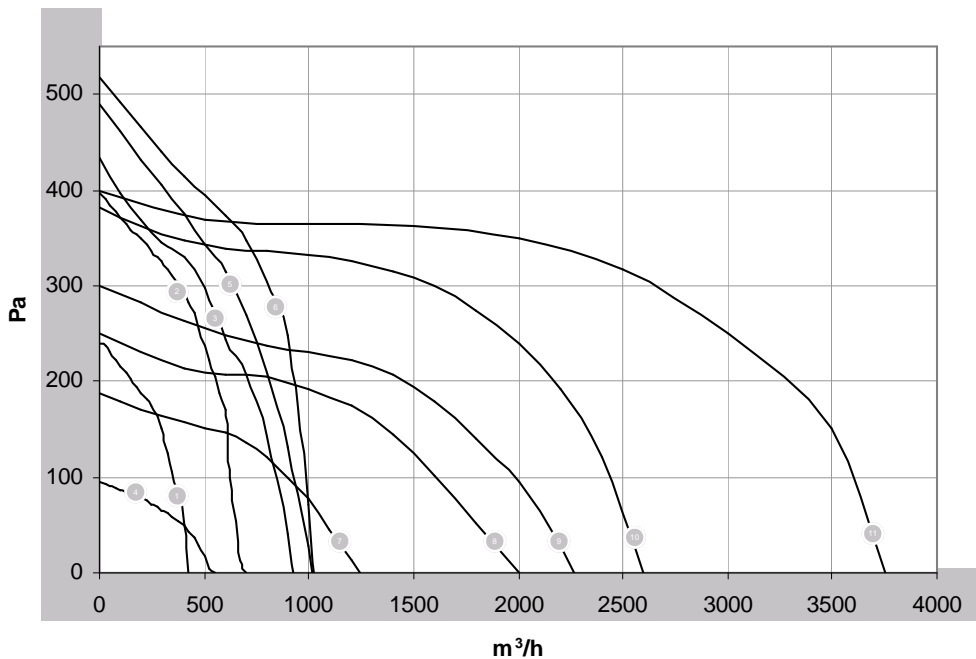

- ① D2E097-BI56-50
- ② D2E133-CI33-87
- ③ D2E133-DM27-D8
- ④ D4E133-AA01-57
- ⑤ D2E146-AP43-62
- ⑥ D2E146-AP47-75
- ⑦ D4E160-EG06-11
- ⑧ D4E180-BA02-25
- ⑨ D4E200-BA05-50
- ⑩ D4E225-BC01-36
- ⑪ D4E250-BA01-12

AC centrifugal blowers

Dual inlet, sizes 097 to 250

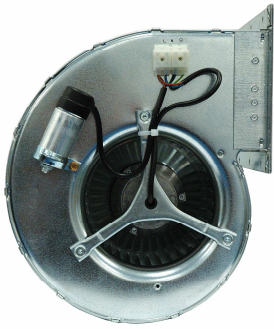

Dimensions

Type	A	B	C	D	E	H	I	K	L	M	N	O	P	R
D2E097-BI56-50	180	168	100	88	67	79.5	146	162	86	165	68	114	62.5	5.5
D2E133-CI33-87	206	190	142	126	102	112	168	204	97	213	93.5	145	67.5	5.5
D2E133-DM27-D8	270	254	142	126	102	112	232	204	97	213	98	145	67.5	5.5
D4E133-AA01-57	254	238	108	92	69	112	215	171.5	88	180	76	145	66	5.5
D2E146-AP43-62	270	254	142	126	102	117	232	206	97	219	98	145	69	5.5
D2E146-AP47-75	270	254	142	126	102	117	232	206	97	219	98	145	69	5.5
D4E160-EG06-11	270	254	145	129	107	130	232	225	102	241	100.5	175	87	5.5
D4E180-BA02-25	309	289	188	168	134	149	225	296	133	333	136	192	130	7
D4E200-BA05-50	341	321	200	180	146	167	287	327	146	371	151	213	147	7
D4E225-BC01-36	341	321	200	180	146	194	287	327	158	370	151	242	146	7
D4E250-BA01-12	349	328	218	190	167	200	298	387	194	392	173	275	135.5	7

Detail Drawing for indication purposes only.

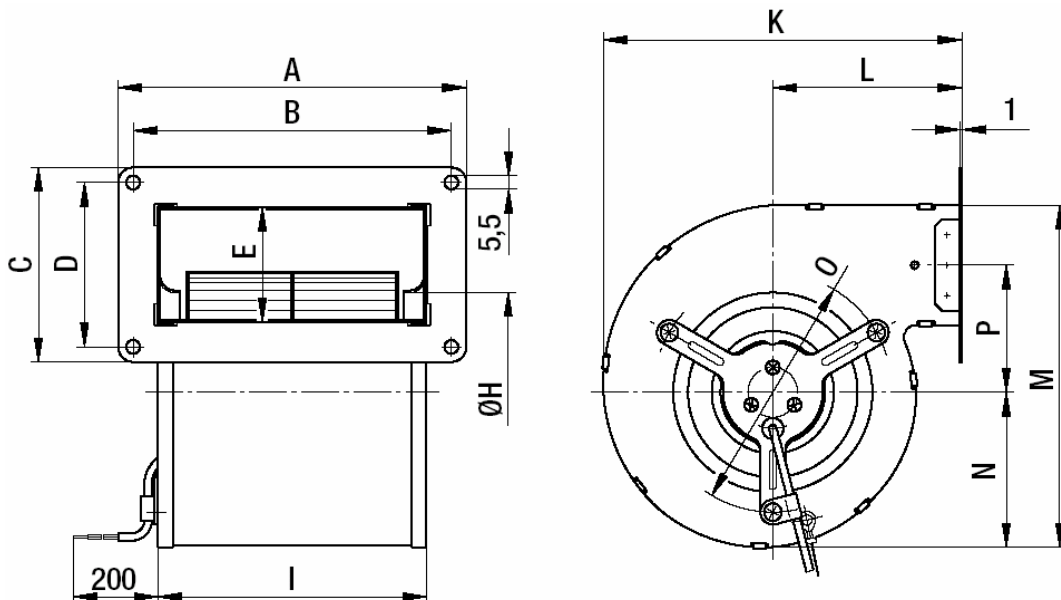

AC centrifugal blowers

Dual inlet, sizes 097 to 250



Acoustic Data (Hz)

Type	125	250	500	1k	2k	4k	8k	16k	Max dB(A)
D2E097-BI56-50	27.6	39.4	43.7	47.3	47.1	43.6	41.0	30.6	58.3
D2E133-CI33-87	27.0	42.5	52.3	55.0	50.9	49.3	44.6	30.4	58.7
D2E133-DM27-D8	33.7	43.3	49.1	51.1	46.3	42.1	39.1	24.4	57.9
D4E133-AA01-57	18.3	34.4	52.7	49.4	46.1	42.9	37.0	19.5	55.1
D2E146-AP43-62	38.5	49.4	53.7	50.0	46.6	45.5	41.5	31	59.6
D2E146-AP47-75	41.8	55.4	57.5	52.8	50.4	47.0	43.7	34.4	62.8
D4E160-EG06-11	42.2	49.9	52.9	53.4	50.6	47.6	41.1	31.5	63.4
D4E180-BA02-25	42.7	57.3	59.4	60.6	57.4	53.9	49.2	34.0	65.3
D4E200-BA05-50	50.3	61.0	57.3	53.9	50.4	46.6	43.4	33.5	64.3
D4E225-BC01-36	42.8	58.1	61.8	61.7	58.7	55.3	50.4	36.0	66.8
D4E250-BA01-12	62.7	67.4	63.1	62.3	64.4	63.6	57.6	50.9	75.0

Connection Diagrams

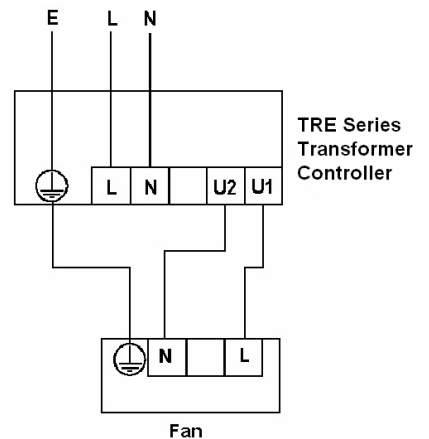
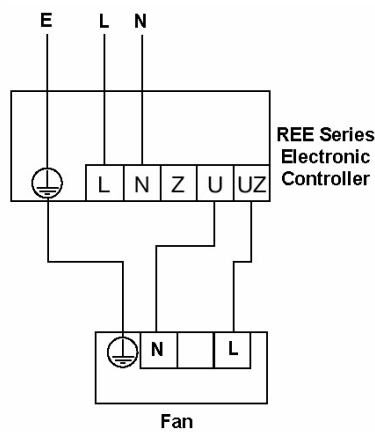
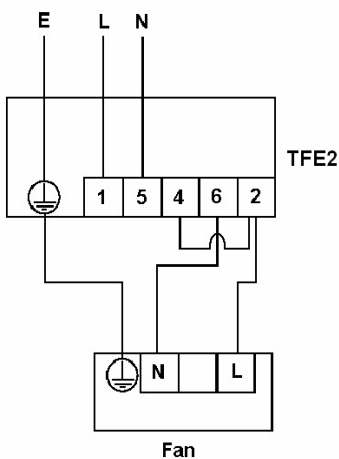

Accessories

Accessories

Type	Overload	Electronic	Transformer	
D2E097-BI56-50	①	TFE2	REE10	TRE1.5
D2E133-CI33-87	②	TFE2	REE10	TRE1.5
D2E133-DM27-D8	③	TFE2	REE10	TRE1.5
D4E133-AA01-57	④	TFE2	REE10	TRE1.5
D2E146-AP43-62	⑤	TFE2	REE30	TRE1.5
D2E146-AP47-75	⑥	TFE2	REE30	TRE1.5
D4E160-EG06-11	⑦	TFE2	REE10	TRE1.5
D4E180-BA02-25	⑧	TFE2	REE30	TRE2
D4E200-BA05-50	⑨	TFE2	REE30	TRE2
D4E225-BC01-36	⑩	TFE2	REE50	TRE4
D4E250-BA01-12	⑪	TFE2	REE70	TRE7.5

Single Phase Motor Protection / Starter



TFE2 (0.4 -10A, IP54)
-25°C - +40°C

The TFE2 is a 230 volt single phase, 10 amp starter and motor protection device. Start / Stop operation is via push button controls on the front of the unit. If the mains supply is interrupted the motor will restart when the power returns.

Motor protection operation will monitor the thermal overload device fitted to the motors and shut down if an over temperature situation arises. The unit will remain off until restarted manually.

Dimensions:
TFE2, 80mm(W) x 150mm(H) x 97.5mm(D)

Single Phase Electronic Speed Control



REE10 (1A)
REE30 (3A)
REE50 (5A)
REE70 (7A)
REE100 (10A)
40°C Max

The REE range is a stepless electronic speed control for single phase fans (230 volt/50Hz). Start / stop and speed control operation is via switch and dial controls on the front of the unit. If the mains supply is interrupted the motor will restart when the power returns.

Separate motor protection devices will be required for each fan (TFE2). One unit may control several fans provided the maximum current rating of the controller is not exceeded.

Dimensions:
REE10, 104mm(W) x 84mm(H) x 40mm(D)
REE30, 131mm(W) x 101mm(H) x 50mm(D)
REE50, 118mm(W) x 95mm(H) x 57mm(D)
REE70, 120mm(W) x 95mm(H) x 73mm(D)
REE100, 104mm(W) x 146mm(H) x 84mm(D)

Single Phase Transformer Speed Control



TRE1.5 (1.45A, IP54)
TRE2 (2.1A, IP54)
TRE4 (4A, IP54)
TRE7.5 (7A, IP54)
40°C Max

The TRE range is a stepped transformer speed control for single phase fans (230 volt/50Hz). Start / stop and speed control operation is via a single selector switch control knob on the front of the unit. 5 set speed points are selectable from the control knob. If the mains supply is interrupted the motor will restart when the power returns.

Separate motor protection devices will be required for each fan (TFE2). One unit may control several fans provided the maximum current rating of the controller is not exceeded.

Dimensions:
TRE1.5, 200mm(W) x 150mm(H) x 150mm(D)
TRE2, 200mm(W) x 150mm(H) x 150mm(D)
TRE4, 200mm(W) x 150mm(H) x 150mm(D)
TRE7.5, 200mm(W) x 150mm(H) x 150mm(D)

ebm-papst UK Ltd.

Springfield Lyons Approach,
Chelmsford,
Essex,
CM2 5EZ.

Tel: 01245 468555
Fax: 01245 466336

h&vsales@uk.ebmpapst.com
www.ebmpapst.co.uk

Компания «Life Electronics» занимается поставками электронных компонентов импортного и отечественного производства от производителей и со складов крупных дистрибьюторов Европы, Америки и Азии.

С конца 2013 года компания активно расширяет линейку поставок компонентов по направлению коаксиальный кабель, кварцевые генераторы и конденсаторы (керамические, пленочные, электролитические), за счёт заключения дистрибьюторских договоров

Мы предлагаем:

- Конкурентоспособные цены и скидки постоянным клиентам.
- Специальные условия для постоянных клиентов.
- Подбор аналогов.
- Поставку компонентов в любых объемах, удовлетворяющих вашим потребностям.
- Приемлемые сроки поставки, возможна ускоренная поставка.
- Доставку товара в любую точку России и стран СНГ.
- Комплексную поставку.
- Работу по проектам и поставку образцов.
- Формирование склада под заказчика.
- Сертификаты соответствия на поставляемую продукцию (по желанию клиента).
- Тестирование поставляемой продукции.
- Поставку компонентов, требующих военную и космическую приемку.
- Входной контроль качества.
- Наличие сертификата ISO.

В составе нашей компании организован Конструкторский отдел, призванный помогать разработчикам, и инженерам.

Конструкторский отдел помогает осуществить:

- Регистрацию проекта у производителя компонентов.
- Техническую поддержку проекта.
- Защиту от снятия компонента с производства.
- Оценку стоимости проекта по компонентам.
- Изготовление тестовой платы монтаж и пусконаладочные работы.



Тел: +7 (812) 336 43 04 (многоканальный)

Email: org@lifeelectronics.ru