



**Eval Kit Manual**

# **AS5048**

## **Adapter Board**

**AS5048-EK-AB**

## Table of Contents

1	Introduction .....	3
1.1	Kit Content .....	3
2	Board Description.....	4
2.1	Mounting the AS5048 adapter board .....	5
3	AS5048 adapter board and pinout .....	6
4	Operation cases .....	7
4.1	One Device SPI mode, unidirectional – 3 wire .....	7
4.2	One device SPI mode, bidirectional – 4 wire .....	8
4.3	Multi devices SPI Daisy chain mode.....	9
5	Software example source code.....	10
6	AS5048-EK-AB Hardware.....	12
6.1	AS5048-EK-AB schematics .....	12
6.2	AS5048-EK-AB PCB layout .....	13
7	Ordering & Contact Information .....	14
8	Copyrights & Disclaimer.....	15

## Revision History

Revision	Date	Owner	Description
1.0	01.10.2009		Initial version
1.1	18.10.2013	azen	Updated to new template
1.2	14.01.2013	rph	Minor corrections in section 4.1
1.3	01.07.2014	mzie	Updated ordering code, added section 1.1, updated figure 2-9, updated source code

## 1 Introduction

The AS5048 adapter board is a small PCB allowing simple and quick testing or evaluation of the AS5048 magnetic position sensor without the need to build a test fixture or design an own PCB.

### 1.1 Kit Content

Figure 1: Kit Content



Pos.	Item	Comment
1	AS5048 adapter board	P1 unpopulated
2	Magnet AS5000-MD6H-2	Diametric Magnet, D6x2.5mm, NdFeB, Bomatec AG

## 2 Board Description

The PCB can either be connected to an external microcontroller or to the Universal Connector Board (AS5xxx-UCB) in combination with a NI USB-8451 box and a provided LabVIEW software.

P1 has to be populated with a 1x8 pin header and is required for power supply as well as SPI/I2C and PWM interfaces.

The PCB is available in two versions. Either populated with an AS5048A with SPI or AS5048B with I2C interface.

**Figure 2: AS5048 adapter board**



## 2.1 Mounting the AS5048 adapter board

Figure 3: Mounting and dimensions

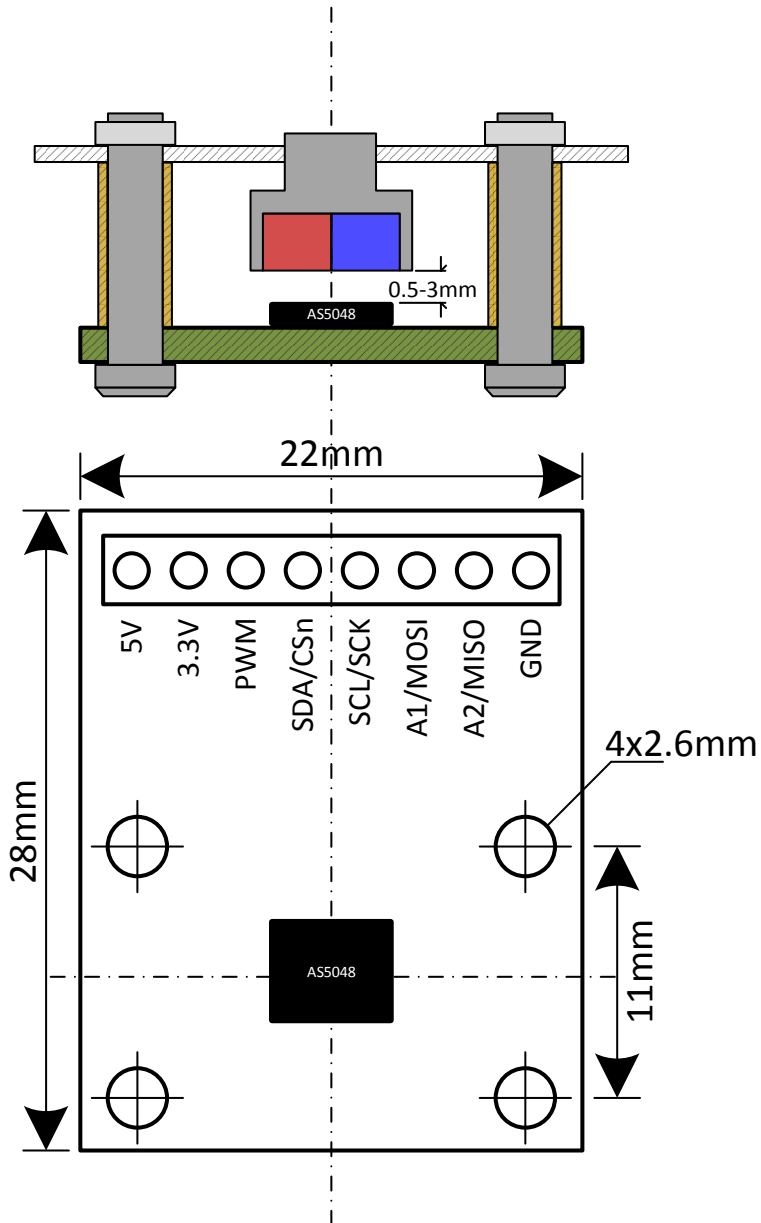

A 6x2.5mm diametric magnet must be placed over or under the AS5048 sensor, and should be centered on the middle of the package with a tolerance of 0.5mm. The airgap between the magnet surface and the package should be maintained in the range 0.5mm to 3mm. The magnet holder must not be ferromagnetic. Materials as brass, copper, aluminum, stainless steel are the best choices to make this part.

### 3 AS5048 adapter board and pinout

Figure 4: AS5048 adapter board connectors and encoder pinout



Pin# Board	Pin# AS5048	Symbol Board	Description
P1 – 1	11	5V	Supply voltage
P1 – 2	12	3.3V	3V-Regulator output; internally regulated from VDD. Connect to VDD for 3V supply voltage
P1 – 3	14	PWM	Pulse width modulation output
P1 – 4	1	SDA/CSn	SPI chip select-active low; shared with I2C data pin
P1 – 5	2	SCL/SCK	SPI clock input; shared with I2C clock input
P1 – 6	4	A1/MOSI	SPI master out/slave in; shared with I2C address selection pin 1
P1 – 7	3	A2/MISO	SPI master in/slave out; shared with I2C address selection pin 2
P1 – 8	13	GND	Supply ground

## 4 Operation cases

The most complete and accurate solution for a MCU to read the angle of a magnet is the SPI interface.

### 4.1 One Device SPI mode, unidirectional – 3 wire

The AS5048-EK-AB can be directly connected to an industry standard SPI port of a microcontroller. The minimum connection requirement for unidirectional communication (angle + alarm values reading) between the microcontroller and the AS5048 are MISO, SCK, SS/.

The angle will be read at each 16-bit SPI transfer. See AS5048 datasheet register table, register 3FFFh.

**Figure 5: Using the SPI Interface unidirectional with a microcontroller**

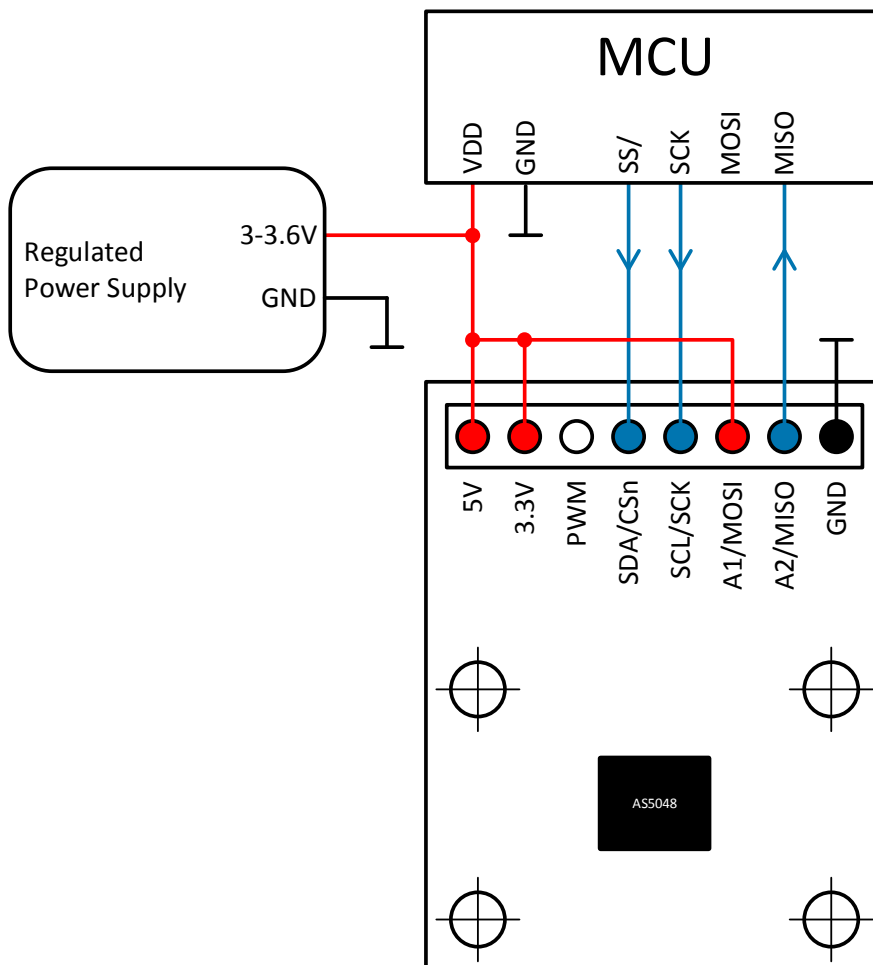

## 4.2 One device SPI mode, bidirectional – 4 wire

If other registers than only angle values have to be read, or in order to write registers into the AS5048, the signal MOSI is necessary.

**Figure 6: Using the SPI Interface biidirectional with a microcontroller**

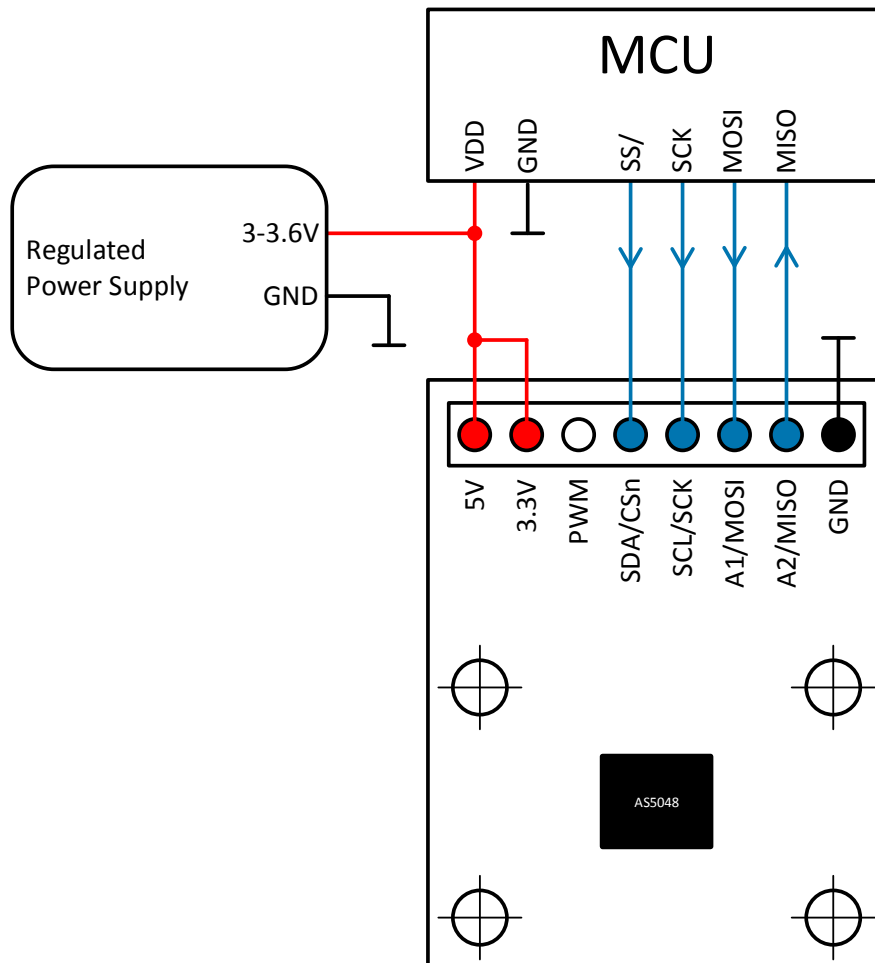



### 4.3 Multi devices SPI Daisy chain mode

The AS5048 can be daisy chained, using 4 wires only for SPI communication.

In this configuration with  $n$  x encoders, the sequence will be processed as follow:

- MCU sets SS/ = 0
- MCU shifts  $n$  x 16-bit (e.g. READ command FFFFh) through the chain
- MCU sets SS/=1

At that point all the  $n$  x encoders have received the READ command FFFFh.

- MCU sets SS/=0
- MCU shifts  $n$  x 16-bit (e.g. NOP command 0000h)
- MCU sets SS/=1

At that point the  $n$  x 16-bit received on MISO are the  $n$  x angle values.

**Figure 7: Multi Devices in Daisy chain mode**

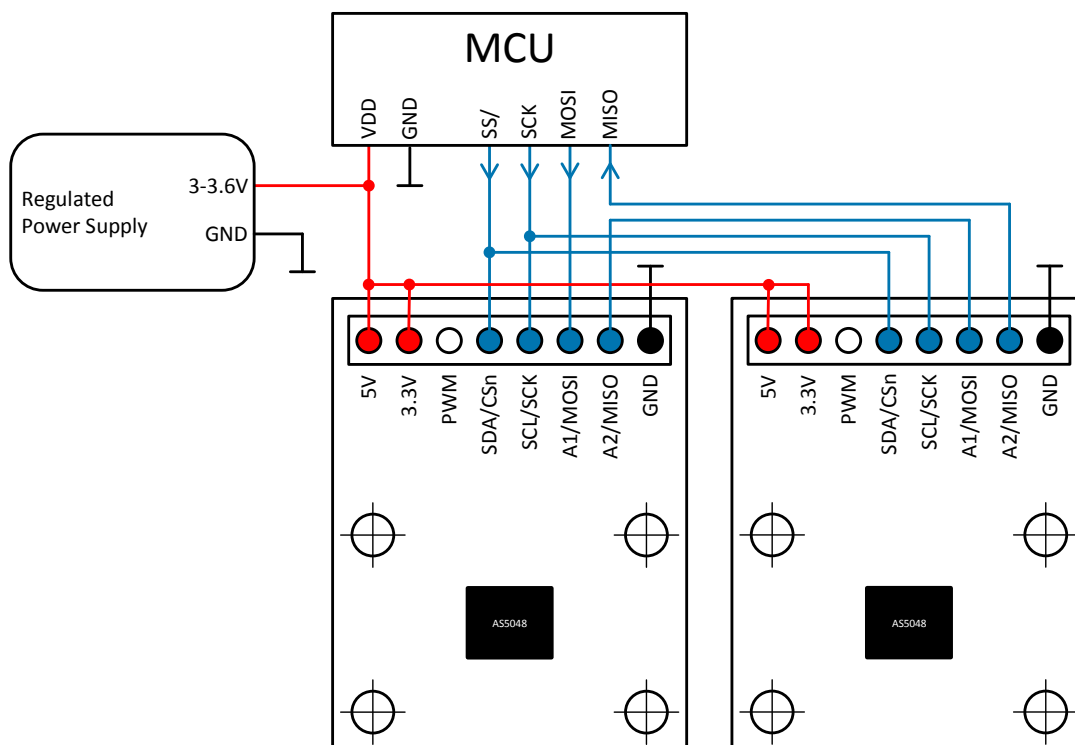

## 5 Software example source code

The following source code shows a 4-wire SPI application case.

```

/!*
*****
* \brief Reads out chip data via SPI interface
*
* This function is used to read out cordic value from chips supporting SPI
* interface.
* After calling this function the data can be displayed using #displayData.
*
* \param[in] die : index of the die to read out.
* \param[out] dd : Buffer of type #t_displayData where the read out data
*                  will be written to.
*
*****
*/
static void spiReadData(u8 die, t_displayData * dd)
{
    umword i;
    u16 dat;
    u16 agcreg;
#ifdef AS5048_CHIPDESCRIPTION
    u16 magreg;
#endif
    PARAMETER_UNUSED(die);

    dd->angleprec = 0;
    /* read agc value */
    for (i = 0; i < 2; i++)
    {
        /* the result is available only just in the second transfer.
           transfers must be separated by chip selects */
        dat = SPI_CMD_READ | SPI_REG_AGC;
        dat |= spiCalcEvenParity(dat);
        spiTransfer((u8*)&dat, sizeof(u16));
    }
    agcreg = dat;

#ifdef AS5048_CHIPDESCRIPTION
    for (i = 0; i < 2; i++)
    {
        /* the result is available only just in the second transfer.
           transfers must be separated by chip selects */
        dat = SPI_CMD_READ | SPI_REG_MAG;

```

```

        dat |= spiCalcEvenParity(dat) << 15;
        spiTransfer((u8*)&dat, sizeof(u16));
    }
    magreg = dat;
#endif
    for (i = 0; i < 2; i++)
    {
        /* the result is available only just in the second transfer.
           transfers must be separated by chip selects */
        dat = SPI_CMD_READ | SPI_REG_DATA;
        dat |= spiCalcEvenParity(dat);
        spiTransfer((u8*)&dat, sizeof(u16));
    }

#ifdef AS5048_CHIPDESCRIPTION
    if ((dat & 0x4000) || (agcreg & 0x4000) || (magreg & 0x4000))
#else
    if (((dat >> 1) & 0x1) || ((agcreg >> 1) & 0x1))
#endif
    {
        /* error flag set - need to reset it */
        dat = SPI_CMD_READ | SPI_REG_CLRERR;
        dat |= spiCalcEvenParity(dat);
        spiTransfer((u8*)&dat, sizeof(u16));
    }
    else
    {
#ifdef AS5048_CHIPDESCRIPTION
        dd->agc = agcreg & 0xff;
        dd->value = dat & (currentChipDescription->positions - 31 - 1);
        dd->angle = (dd->value * 360) / currentChipDescription->positions;
        dd->magnitude = magreg & (currentChipDescription->positions - 31 - 1);
        dd->alarmLo = (agcreg >> 10) & 0x1;
        dd->alarmHi = (agcreg >> 11) & 0x1;
#else
        dd->agc = (agcreg >> 2) & 0x3F;
        dd->value = (dat >> 2) & (currentChipDescription->positions - 1);
        dd->angle = (dd->value * 360) / currentChipDescription->positions;
        dd->alarmLo = (dat >> 14) & 0x1;
        dd->alarmHi = (dat >> 15) & 0x1;
#endif
    }
}

```

## 6 AS5048-EK-AB Hardware

### 6.1 AS5048-EK-AB schematics

Figure 8: AS5048-EK-AB schematics

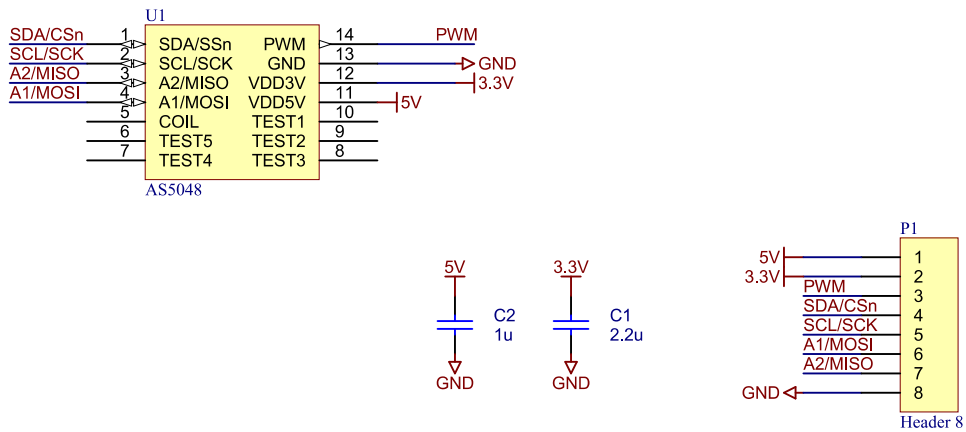

## 6.2 AS5048-EK-AB PCB layout

Figure 9: AS5048-EK-AB PCB layout



## 7 Ordering & Contact Information

Ordering Code	Description
AS5048-EK-AB	AS5048 Eval Kit Adapter Board

**Buy our products or get free samples online at:**

[www.ams.com/ICdirect](http://www.ams.com/ICdirect)

**Technical Support is available at:**

[www.ams.com/Technical-Support](http://www.ams.com/Technical-Support)

**Provide feedback about this document at:**

[www.ams.com/Document-Feedback](http://www.ams.com/Document-Feedback)

**For further information and requests, e-mail us at:**

[ams\\_sales@ams.com](mailto:ams_sales@ams.com)

**For sales offices, distributors and representatives, please visit:**

[www.ams.com/contact](http://www.ams.com/contact)

### Headquarters

ams AG

Tobelbaderstrasse 30

8141 Unterpemstaetten

Austria, Europe

Tel: +43 (0) 3136 500 0

Website: [www.ams.com](http://www.ams.com)

## 8 Copyrights & Disclaimer

Copyright ams AG, Tobelbader Strasse 30, 8141 Unterpremstaetten, Austria-Europe. Trademarks Registered. All rights reserved. The material herein may not be reproduced, adapted, merged, translated, stored, or used without the prior written consent of the copyright owner.

Demo Kits, Evaluation Kits and Reference Designs are provided to recipient on an “as is” basis for demonstration and evaluation purposes only and are not considered to be finished end-products intended and fit for general consumer use, commercial applications and applications with special requirements such as but not limited to medical equipment or automotive applications. Demo Kits, Evaluation Kits and Reference Designs have not been tested for compliance with electromagnetic compatibility (EMC) standards and directives, unless otherwise specified. Demo Kits, Evaluation Kits and Reference Designs shall be used by qualified personnel only.

ams AG reserves the right to change functionality and price of Demo Kits, Evaluation Kits and Reference Designs at any time and without notice.

Any express or implied warranties, including, but not limited to the implied warranties of merchantability and fitness for a particular purpose are disclaimed. Any claims and demands and any direct, indirect, incidental, special, exemplary or consequential damages arising from the inadequacy of the provided Demo Kits, Evaluation Kits and Reference Designs or incurred losses of any kind (e.g. loss of use, data or profits or business interruption however caused) as a consequence of their use are excluded.

ams AG shall not be liable to recipient or any third party for any damages, including but not limited to personal injury, property damage, loss of profits, loss of use, interruption of business or indirect, special, incidental or consequential damages, of any kind, in connection with or arising out of the furnishing, performance or use of the technical data herein. No obligation or liability to recipient or any third party shall arise or flow out of ams AG rendering of technical or other services.

Компания «Life Electronics» занимается поставками электронных компонентов импортного и отечественного производства от производителей и со складов крупных дистрибьюторов Европы, Америки и Азии.

С конца 2013 года компания активно расширяет линейку поставок компонентов по направлению коаксиальный кабель, кварцевые генераторы и конденсаторы (керамические, пленочные, электролитические), за счёт заключения дистрибьюторских договоров

Мы предлагаем:

- Конкуренспособные цены и скидки постоянным клиентам.
- Специальные условия для постоянных клиентов.
- Подбор аналогов.
- Поставку компонентов в любых объемах, удовлетворяющих вашим потребностям.
- Приемлемые сроки поставки, возможна ускоренная поставка.
- Доставку товара в любую точку России и стран СНГ.
- Комплексную поставку.
- Работу по проектам и поставку образцов.
- Формирование склада под заказчика.
- Сертификаты соответствия на поставляемую продукцию (по желанию клиента).
- Тестирование поставляемой продукции.
- Поставку компонентов, требующих военную и космическую приемку.
- Входной контроль качества.
- Наличие сертификата ISO.

В составе нашей компании организован Конструкторский отдел, призванный помогать разработчикам, и инженерам.

Конструкторский отдел помогает осуществить:

- Регистрацию проекта у производителя компонентов.
- Техническую поддержку проекта.
- Защиту от снятия компонента с производства.
- Оценку стоимости проекта по компонентам.
- Изготовление тестовой платы монтаж и пусконаладочные работы.



Тел: +7 (812) 336 43 04 (многоканальный)

Email: [org@lifeelectronics.ru](mailto:org@lifeelectronics.ru)