

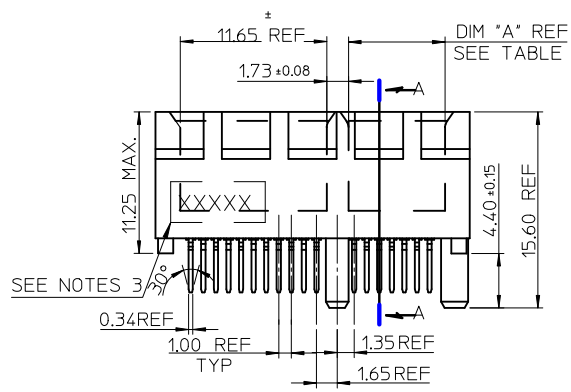

- NOTES:
- 1.MATERIALS:
1-1.HOUSING: SEE TABLE ,GLASS FIBER FILLED UL94V-0, COLOR: SEE TABLE.
1-2.CONTACT: SEE TABLE
 - 2.PLATING:
2-1.CONTACT AREA: GOLD, THICKNESS : SEE TABLE .
2-2.SOLDER TAIL: 100 MICRINCH MIN. TIN PLATING.
2-3.UNDER PLATING: NICKEL PLATING OVERALL.
 - 3.WEEK CODE: XX(YEAR) XXI(WEEK) X(LOCATION),
 - 4.PRODUCT SPECIFICATION REFER TO PS-87715-200.
 - 5.PACKAGING SPECIFICATION REFER TO PK-87715-207.
 - 6.TEST SUMMARY:REFER TO TS-87715-207.
 - 7.LEAD FREE AND ROHS COMPLIANCE PRODUCT.



| CONNECTOR LINK WIDTH | # POS REF | N | DIM 'A' | DIM 'B' | DIM 'C' |
|----------------------|-----------|----|---------|---------|---------|
| X1 | 36 | 6 | 7.65 | 25.00 | 9.15 |
| X4 | 64 | 20 | 21.65 | 39.00 | 23.15 |
| X8 | 98 | 37 | 38.65 | 56.00 | 40.15 |
| X16 | 164 | 70 | 71.65 | 89.00 | 73.15 |

| PCB THK (REF) | DIM 'D' |
|---------------|---------|
| 1.60 | 2.30 |
| 1.58 | 2.54 |
| 2.36 | 3.00 |

| | | | | | | | | | | |
|---|--|--------------------------------------|--|--------|----------------------------|---|--------------------|--------------|------------------------|---|
| REVISED IEC NO: SH2010-0468 DRWNR:ZHANG CHYKD:ALLEN L LIN APPR:X.J.SONG | 2010/06/15 2004/07/20 2010/07/02 | QUALITY SYMBOLS F=0 E=0 A=0 | GENERAL TOLERANCES (UNLESS SPECIFIED) | | DIMENSION STYLE MM ONLY | | SCALE | DESIGN UNITS | THIRD ANGLE PROJECTION | |
| | | | 4 PLACES | ± --- | ± --- | mm | INCH | DRAWN BY | DATE | TITLE |
| | | | 3 PLACES | ± --- | ± --- | | | TOM | 2004/07/20 | PCI EXPRESS EDGE CARD CONNECTOR (LEAD FREE VERSION) |
| | | | 2 PLACES | ± 0.25 | ± --- | | | CHECKED BY | DATE | |
| 1 PLACE | ± 0.25 | ± --- | | | ALLEN LIN | 2004/07/20 | MOLEX INCORPORATED | SHEET NO. | | |
| | | | ANGULAR ± 3 ° | | APPROVED BY | DATE | DOCUMENT NO. | 1 OF 4 | | |
| | | | DRAFT WHERE APPLICABLE MUST REMAIN WITHIN DIMENSIONS | | WILSON | 2004/07/20 | SD-87715-207 | | | |
| | | | | | MATERIAL NO. | | | | | |
| | | | | | SEE SHEET 4 | | | | | |
| | | | | | SIZE A3 | THIS DRAWING CONTAINS INFORMATION THAT IS PROPRIETARY TO MOLEX INCORPORATED AND SHOULD NOT BE USED WITHOUT WRITTEN PERMISSION | | | | |

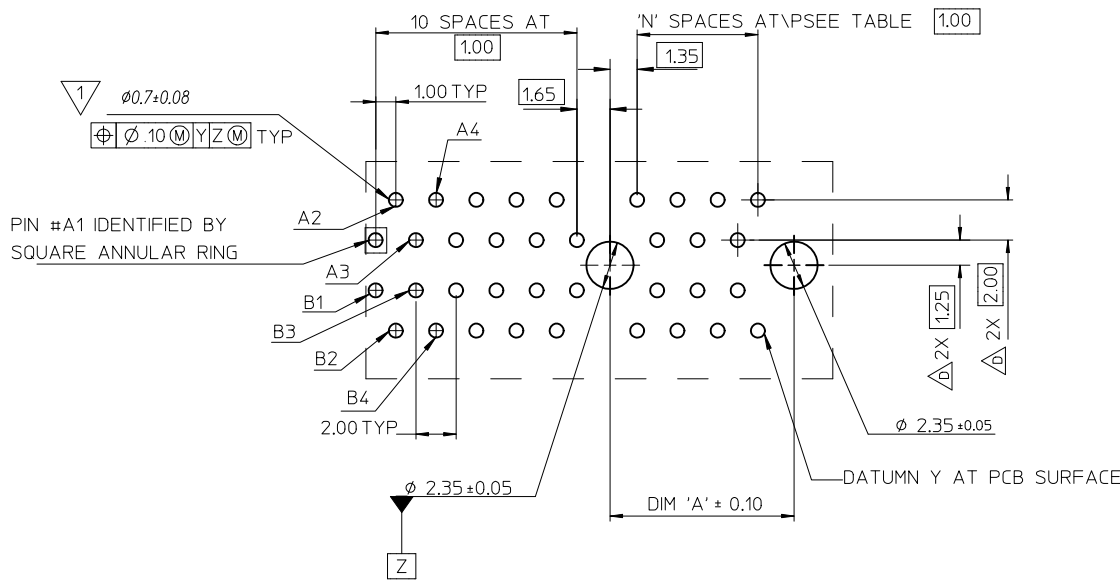

1 THE HORIZONTAL AXIS FOR THE HOLE PATTERN IS ESTABLISHED BY A LINE THROUGH THE CENTER OF THE TWO $\phi 2.35$ HOLES. THE VERTICAL AXIS IS 90° TO THE HORIZONTAL AXIS, THROUGH THE CENTER OF DATUM Z

PIN #A1 IDENTIFIED BY SQUARE ANNULAR RING

| CONNECTOR LINK WIDTH | # POS REF | N | DIM 'A' |
|----------------------|-----------|----|---------|
| X1 | 36 | 6 | 9.15 |
| X4 | 64 | 20 | 23.15 |
| X8 | 98 | 37 | 40.15 |
| X16 | 164 | 70 | 73.15 |

| | | | | | | | | | | | | |
|--|--|---|--|------------|---|------------|--------------|---|------------------------|--------------|--|--|
| SEE SHEET 1 EC NO: SH2010-0468 DRAWN: ZHANG CHKD: ALLEN LIN APPR: XJSONG | 2010/06/15 2004/07/20 2010/07/02 | DESCRIPTION QUALITY SYMBOLS $F_A=0$ $F_G=0$ $F_P=0$ | GENERAL TOLERANCES (UNLESS SPECIFIED) | | DIMENSION STYLE MM ONLY | | SCALE | DESIGN UNITS METRIC | THIRD ANGLE PROJECTION | | | |
| | | | | mm | INCH | DRAWN BY | DATE | TITLE | | | | |
| | | | 4 PLACES | ± --- | ± --- | TOM | 2004/07/20 | PCI EXPRESS EDGE CARD CONNECTOR (LEAD FREE VERSION) | | | | |
| | | | 3 PLACES | ± --- | ± --- | CHECKED BY | DATE | | | | | |
| 2 PLACES | ± 0.25 | ± --- | ALLEN LIN | 2004/07/20 | MOLEX INCORPORATED | | | | | | | |
| 1 PLACE | ± 0.25 | ± --- | APPROVED BY | DATE | | | | | | | | |
| ANGULAR ± 3° | | | DRAFT WHERE APPLICABLE MUST REMAIN WITHIN DIMENSIONS | | WILSON | | 2004/07/20 | MATERIAL NO. | | DOCUMENT NO. | | |
| | | | | | SEE SHEET 4 | | SD-87715-207 | | SHEET NO. 2 OF 4 | | | |
| | | | | | THIS DRAWING CONTAINS INFORMATION THAT IS PROPRIETARY TO MOLEX INCORPORATED AND SHOULD NOT BE USED WITHOUT WRITTEN PERMISSION | | | | | | | |



← I/O PANEL DIRECTION

PRIMARY (COMPONENT) SIDE

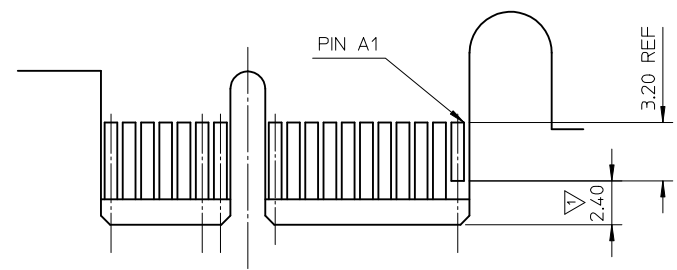

I/O PANEL DIRECTION →

SECONDARY (SOLDER) SIDE

- 1 NO TIE BAR PERMITTED FROM CARD EDGE TO LEADING EDGE OF PAD FOR PINS A1 AND "C".
- 2 CHAMFER EDGES MUST BE FREE OF CUTTING BURRS.
- 3. TOLERANCE: .XX±.13

| CONNECTOR LINK WIDTH | # POS REF | N | DIM 'B' | 'C' Δ |
|----------------------|-----------|----|---------|----------------------|
| X1 | 36 | 6 | 8.15 | B17 |
| X4 | 64 | 20 | 22.15 | B17, B31 |
| X8 | 98 | 37 | 39.15 | B17, B31 B48 |
| X16 | 164 | 70 | 72.15 | B17, B31 B48, B81 |

| | | | | | | | |
|---|-----------------------|---------------------------------------|---|---|--------------|------------------------|--|
| SEE SHEET 1 EC NO: SH2010-0468 DRWR: ZHANG 2010/06/15 CHKD: ALLEN LIN 2004/07/20 APPR: XJ.SONG 2010/07/02 | QUALITY SYMBOLS | GENERAL TOLERANCES (UNLESS SPECIFIED) | DIMENSION STYLE | SCALE | DESIGN UNITS | THIRD ANGLE PROJECTION | |
| | $\nabla_{\text{A}}=0$ | mm INCH | MM ONLY | | METRIC | | |
| | $\nabla_{\text{B}}=0$ | 4 PLACES ± --- ± --- | DRAWN BY DATE | TITLE | | | |
| | $\nabla_{\text{C}}=0$ | 3 PLACES ± --- ± --- | TOM 2004/07/20 | PCI EXPRESS EDGE CARD CONNECTOR (LEAD FREE VERSION) | | | |
| | 2 PLACES ± 0.25 ± --- | CHECKED BY DATE | MOLEX INCORPORATED | | | | |
| | 1 PLACE ± 0.25 ± --- | ALLEN LIN 2004/07/20 | MATERIAL NO. DOCUMENT NO. | | | | |
| | ANGULAR ± 3° | APPROVED BY DATE | SEE SHEET 4 SD-87715-207 | | | | |
| | | WILSON 2004/07/20 | SHEET NO. 3 OF 4 | | | | |
| | | | THIS DRAWING CONTAINS INFORMATION THAT IS PROPRIETARY TO MOLEX INCORPORATED AND SHOULD NOT BE USED WITHOUT WRITTEN PERMISSION | | | | |

| MOLEX P/N | CIRCUIT SIZE | HOUSING MATERIAL | HOUSING COLOR | TERMINAL MATERIAL | CONTACT PLATING | SOLDER TAIL 'D' LENGTH | |
|------------|--------------|------------------|---------------|-------------------|-----------------|------------------------|------|
| 87715-9001 | 36 | NYLON46 | BLACK | PHOSPHOR BRONZE | 10 MICROINCH | 2.54 | |
| 87715-9003 | | | | | GOLD FLASH | | |
| 87715-9004 | | | | | 10 MICROINCH | 3.00 | |
| 87715-9007 | | | | | GOLD FLASH | | |
| 87715-9008 | | | | | 15 MICROINCH | | 2.30 |
| | | | | | | | |

| MOLEX P/N | CIRCUIT SIZE | HOUSING MATERIAL | HOUSING COLOR | TERMINAL MATERIAL | CONTACT PLATING | SOLDER TAIL 'D' LENGTH |
|------------|--------------|------------------|---------------|-------------------|-----------------|------------------------|
| 87715-9100 | 64 | NYLON46 | BLACK | PHOSPHOR BRONZE | GOLD FLASH | 2.54 |
| 87715-9101 | | | | | 10 MICROINCH | |
| 87715-9102 | | | | | 15 MICROINCH | 3.00 |
| 87715-9103 | | | | | GOLD FLASH | |
| 87715-9104 | | | | | 10 MICROINCH | |
| 87715-9105 | | | | | 15 MICROINCH | |
| 87715-9106 | | | | | 30 MICROINCH | 2.54 |
| 87715-9107 | | | | | GOLD FLASH | 2.30 |
| 87715-9108 | | | | | 15 MICROINCH | |
| 87715-9109 | | | | | 30 MICROINCH | |

| MOLEX P/N | CIRCUIT SIZE | HOUSING MATERIAL | HOUSING COLOR | TERMINAL MATERIAL | CONTACT PLATING | SOLDER TAIL 'D' LENGTH |
|------------|--------------|------------------|---------------|-------------------|-----------------|------------------------|
| 87715-9200 | 98 | NYLON46 | BLACK | PHOSPHOR BRONZE | GOLD FLASH | 2.54 |
| 87715-9201 | | | | | 10 MICROINCH | |
| 87715-9202 | | | | | 15 MICROINCH | 3.00 |
| 87715-9203 | | | | | GOLD FLASH | |
| 87715-9204 | | | | | 10 MICROINCH | |
| 87715-9205 | | | | | 15 MICROINCH | |
| 87715-9206 | | | | | 30 MICROINCH | 2.54 |
| 87715-9207 | | | | | GOLD FLASH | 2.30 |
| 87715-9208 | | | | | 15 MICROINCH | |
| 87715-9209 | | | | | 30 MICROINCH | |

| MOLEX P/N | CIRCUIT SIZE | HOUSING MATERIAL | HOUSING COLOR | TERMINAL MATERIAL | CONTACT PLATING | SOLDER TAIL 'D' LENGTH |
|------------|--------------|------------------|---------------|-------------------|-----------------|------------------------|
| 87715-9602 | 98 | NYLON46 | BLACK | BRASS | 15 MICROINCH | 2.54 |

| MOLEX P/N | CIRCUIT SIZE | HOUSING MATERIAL | HOUSING COLOR | TERMINAL MATERIAL | CONTACT PLATING | SOLDER TAIL 'D' LENGTH |
|------------|--------------|------------------|---------------|-------------------|-----------------|------------------------|
| 87715-9301 | 164 | NYLON46 | BLACK | PHOSPHOR BRONZE | 10 MICROINCH | 2.54 |
| 87715-9304 | | | | | | 3.00 |
| 87715-9307 | | | | | GOLD FLASH | 2.30 |
| 87715-9308 | | | | | 15 MICROINCH | |

| | | | | | | | | |
|--|-----------------|--|--------|-----------------------------------|---|--------------------|---|------------------------|
| SEE SHEET 1 EC NO: SH2010-0468 DRW:RZHANG 2010/06/15 CHKD:ALLEN LIN 2004/07/20 APPR:XJ.SONG 2010/07/02 | QUALITY SYMBOLS | GENERAL TOLERANCES (UNLESS SPECIFIED) | | DIMENSION STYLE MM ONLY | | SCALE | DESIGN UNITS METRIC | THIRD ANGLE PROJECTION |
| | $F_A=0$ | 4 PLACES | mm | INCH | DRAWN BY | DATE | TITLE | |
| | $F_C=0$ | 3 PLACES | ± --- | ± --- | TOM | 2004/07/20 | PCI EXPRESS | |
| | $F_B=0$ | 2 PLACES | ± 0.25 | ± --- | CHECKED BY | DATE | EDGE CARD CONNECTOR (LEAD FREE VERSION) | |
| | 1 PLACE | ± 0.25 | ± --- | ALLEN LIN | 2004/07/20 | MOLEX INCORPORATED | | |
| | | ANGULAR ± 3 ° | | APPROVED BY | DATE | MOLEX INCORPORATED | | |
| | | DRAFT WHERE APPLICABLE MUST REMAIN WITHIN DIMENSIONS | | WILSON | 2004/07/20 | MOLEX INCORPORATED | | |
| | | | | MATERIAL NO. | | DOCUMENT NO. | SHEET NO. | |
| | | | | SEE TABLE | | SD-87715-207 | | 4 OF 4 |
| | | | | SIZE | THIS DRAWING CONTAINS INFORMATION THAT IS PROPRIETARY TO MOLEX INCORPORATED AND SHOULD NOT BE USED WITHOUT WRITTEN PERMISSION | | | |
| | | | | A3 | | | | |

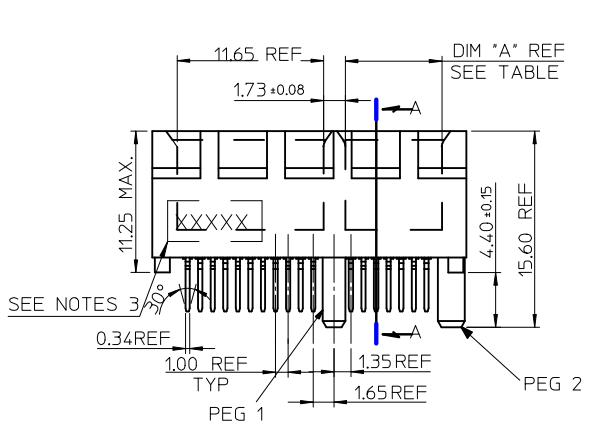
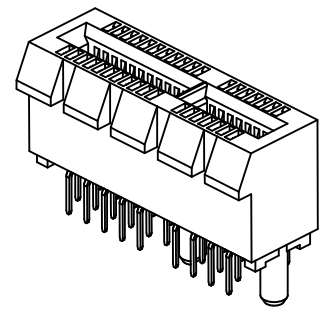

- NOTES:
 1.MATERIALS:
 1-1.HOUSING: SEE TABLE ,GLASS FIBER FILLED UL94V-0, COLOR: SEE TABLE.
 1-2.CONTACT: SEE TABLE
 2.PLATING:
 2-1.CONTACT AREA: GOLD, THICKNESS : SEE TABLE .
 2-2.SOLDER TAIL: 100 MICRONCH MIN. TIN PLATING.
 2-3.UNDER PLATING: NICKEL PLATING OVERALL.
 3.DATE CODE: YY MM DD.
 4.PRODUCT SPECIFICATION REFER TO PS-87715-200.
 5.TEST SUMMARY:REFER TO TS-87715-207.

| CONNECTOR LINK WIDTH | # POS REF | N | DIM 'A' | DIM 'B' | DIM 'C' | PCB THK (REF) | DIM 'D' |
|----------------------|-----------|----|---------|---------|---------|---------------|---------|
| X1 | 36 | 6 | 7.65 | 25.00 | 9.15 | 1.58 | 2.54 |
| X16 | 164 | 70 | 71.65 | 89.00 | 73.15 | 2.36 | 3.00 |

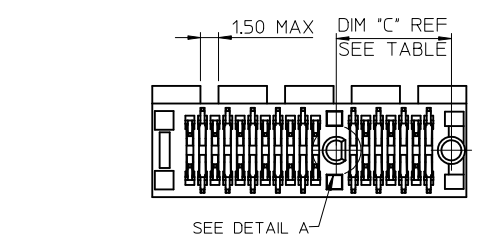

| | | | | | | | |
|---|--|---|---|---|--------------|------------------------|--|
| REVISED EC NO: SH2011-0358 DRWN:FYANG05 CHKD: APPR:RZHANG 2011/06/02 2011/06/07 | QUALITY SYMBOLS | GENERAL TOLERANCES (UNLESS SPECIFIED) | DIMENSION STYLE | SCALE | DESIGN UNITS | THIRD ANGLE PROJECTION | |
| | $\nabla = 0$ $\nabla = 0$ $\nabla = 0$ | mm INCH 4 PLACES ± --- ± --- 3 PLACES ± --- ± --- 2 PLACES ± 0.25 ± --- 1 PLACE ± 0.25 ± --- ANGULAR ± 3° | MM ONLY | DRAWN BY DATE DAVID HU 2007/05/14 CHECKED BY DATE HARVEY 2007/05/14 APPROVED BY DATE JENNY CHEN 2007/05/14 | METRIC | TITLE | PCI EXPRESS EDGE CARD CONNECTOR (LEAD FREE VERSION) MOLEX INCORPORATED DOCUMENT NO. SD-87715-901 SHEET NO. 1 OF 4 |
| | DRAFT WHERE APPLICABLE MUST REMAIN WITHIN DIMENSIONS | SEE SHEET 4 | THIS DRAWING CONTAINS INFORMATION THAT IS PROPRIETARY TO MOLEX INCORPORATED AND SHOULD NOT BE USED WITHOUT WRITTEN PERMISSION | | | | |
| | REV | DESCRIPTION | SIZE | | | | |
| | | A3 | | | | | |



1 THE HORIZONTAL AXIS FOR THE HOLE PATTERN IS ESTABLISHED BY A LINE THROUGH THE CENTER OF THE TWO $\phi 2.35$ HOLES. THE VERTICAL AXIS IS 90° TO THE HORIZONTAL AXIS, THROUGH THE CENTER OF DATUM Z

| CONNECTOR LINK WIDTH | # POS REF | N | DIM 'A' |
|----------------------|-----------|----|---------|
| X1 | 36 | 6 | 9.15 |
| X16 | 164 | 70 | 73.15 |

| | | | | | | | |
|---|--|---|---|---|--|------------------------|--|
| SEE SHEET 1 EC NO: SH2011-0358 DRWN: YANG05 CHKD: APPR: RZHANG REV | QUALITY SYMBOLS | GENERAL TOLERANCES (UNLESS SPECIFIED) | DIMENSION STYLE | SCALE | DESIGN UNITS | THIRD ANGLE PROJECTION | |
| | $F_A=0$ $F_C=0$ $F_P=0$ | mm INCH 4 PLACES ± --- ± --- 3 PLACES ± --- ± --- 2 PLACES ± 0.25 ± --- 1 PLACE ± 0.25 ± --- ANGULAR ± 3° | MM ONLY | DRAWN BY: DAVID HU CHECKED BY: HARVEY APPROVED BY: JENNY CHEN MATERIAL NO. | DATE: 2007/05/14 DATE: 2007/05/14 DATE: 2007/05/14 | METRIC | PCI EXPRESS EDGE CARD CONNECTOR (LEAD FREE VERSION) MOLEX INCORPORATED DOCUMENT NO. SD-87715-901 SHEET NO. 2 OF 4 |
| | DRAFT WHERE APPLICABLE MUST REMAIN WITHIN DIMENSIONS | SEE SHEET 1 | THIS DRAWING CONTAINS INFORMATION THAT IS PROPRIETARY TO MOLEX INCORPORATED AND SHOULD NOT BE USED WITHOUT WRITTEN PERMISSION | | | | |
| | | | | | | | |
| | | | | | | | |



← I/O PANEL DIRECTION

PRIMARY (COMPONENT) SIDE

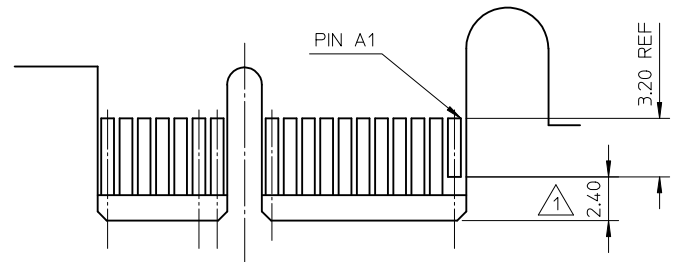

I/O PANEL DIRECTION →

SECONDARY (SOLDER) SIDE

| | | | | | |
|------|---|---|---|---|---|
| 0.10 | ⊙ | V | W | X | ⊙ |
| 0.05 | ⊙ | | | | ⊙ |

- 1 NO TIE BAR PERMITTED FROM CARD EDGE TO LEADING EDGE OF PAD FOR PINS A1 AND "C".
- 2 CHAMFER EDGES MUST BE FREE OF CUTTING BURRS.
- 3 TOLERANCE: .XX±.13

| CONNECTOR LINK WIDTH | # POS REF | N | DIM 'B' | 'C' 1 |
|----------------------|-----------|----|---------|----------------------|
| X1 | 36 | 6 | 8.15 | B17 |
| X16 | 164 | 70 | 72.15 | B17, B31 B48, B81 |

| | | | | | | | |
|--|-----------------------|----------------------|--|-----------------|---|---|------------------------|
| SEE SHEET 1 EC NO: SH2011-0358 DRWN: YANG05 CHKD: APPR: RZHANG | DESCRIPTION REV | QUALITY SYMBOLS | GENERAL TOLERANCES (UNLESS SPECIFIED) | DIMENSION STYLE | SCALE | DESIGN UNITS | THIRD ANGLE PROJECTION |
| | | FA=0 | mm INCH | MM ONLY | METRIC | PCI EXPRESS EDGE CARD CONNECTOR (LEAD FREE VERSION) MOLEX INCORPORATED | |
| | | FC=0 | 4 PLACES ± --- ± --- | DRAWN BY DATE | TITLE | | |
| | | FE=0 | 3 PLACES ± --- ± --- | CHECKED BY DATE | | | |
| | 2 PLACES ± 0.25 ± --- | APPROVED BY DATE | | | | | |
| | | 1 PLACE ± 0.25 ± --- | JENNY CHEN 2007/05/14 | | | | |
| | | ANGULAR ± 3 ° | MATERIAL NO. | SEE SHEET 1 | DOCUMENT NO. | SD-87715-901 | SHEET NO. 3 OF 4 |
| | | | DRAFT WHERE APPLICABLE MUST REMAIN WITHIN DIMENSIONS | SIZE A3 | THIS DRAWING CONTAINS INFORMATION THAT IS PROPRIETARY TO MOLEX INCORPORATED AND SHOULD NOT BE USED WITHOUT WRITTEN PERMISSION | | |



| MOLEX P/N | CIRCUIT SIZE | HOUSING MATERIAL | HOUSING COLOR | TERMINAL MATERIAL | CONTACT PLATING | SOLDER TAIL 'D' LENGTH | PEG 1 | PEG 2 | DESCRIPTION |
|------------|--------------|------------------|---------------|-------------------|-----------------|------------------------|-------|-------|-------------|
| 87715-9000 | 36 | NYLON46 | BLACK | PHOSPHOR BRONZE | GOLD FLASH | 2.54 | WITH | WITH | TOOLED |
| 87715-9002 | | | | | 15 MICROINCH | | | | |
| 87715-9005 | | | | | 15 MICROINCH | 3.00 | | | |
| 87715-9006 | | | | | 30 MICROINCH | | | | |
| 87715-9009 | | | | | 30 MICROINCH | | | | |



| MOLEX P/N | CIRCUIT SIZE | HOUSING MATERIAL | HOUSING COLOR | TERMINAL MATERIAL | CONTACT PLATING | SOLDER TAIL 'D' LENGTH | PEG 1 | PEG 2 | DESCRIPTION |
|------------|--------------|------------------|---------------|-------------------|-----------------|------------------------|-------|-------|-------------|
| 87715-9300 | 164 | NYLON46 | BLACK | PHOSPHOR BRONZE | GOLD FLASH | 2.54 | WITH | WITH | TOOLED |
| 87715-9302 | | | | | 15 MICROINCH | | | | |
| 87715-9303 | | | | | GOLD FLASH | 3.00 | | | |
| 87715-9305 | | | | | 15 MICROINCH | | | | |
| 87715-9306 | | | | | 30 MICROINCH | | | | |
| 87715-9309 | | | | | 30 MICROINCH | | | | |

| | | | | | | |
|--|-------------------------------|--|---|--|------------------|------------------------|
| SEE SHEET 1 EC NO: SH2011-0358 DRAWN: FANG05 CHK'D: APPR: RZHANG 2011/06/02 2011/06/07 | QUALITY SYMBOLS | GENERAL TOLERANCES (UNLESS SPECIFIED) | DIMENSION STYLE | SCALE | DESIGN UNITS | THIRD ANGLE PROJECTION |
| | $F_A=0$ $F_C=0$ $F_P=0$ | mm INCH 4 PLACES ± --- ± --- 3 PLACES ± --- ± --- 2 PLACES ± 0.25 ± --- 1 PLACE ± 0.25 ± --- ANGULAR ± 3 ° | MM ONLY | | METRIC | |
| | | DRAFT WHERE APPLICABLE MUST REMAIN WITHIN DIMENSIONS | DRAWN BY: DAVID HU DATE: 2007/05/14 CHECKED BY: HARVEY DATE: 2007/05/14 APPROVED BY: JENNY CHEN DATE: 2007/05/14 | TITLE: PCI EXPRESS EDGE CARD CONNECTOR (LEAD FREE VERSION) MOLEX INCORPORATED | | |
| | | | MATERIAL NO. SEE SHEET 1 SIZE: A3 THIS DRAWING CONTAINS INFORMATION THAT IS PROPRIETARY TO MOLEX INCORPORATED AND SHOULD NOT BE USED WITHOUT WRITTEN PERMISSION | DOCUMENT NO. SD-87715-901 | SHEET NO. 4 OF 4 | |

Компания «Life Electronics» занимается поставками электронных компонентов импортного и отечественного производства от производителей и со складов крупных дистрибьюторов Европы, Америки и Азии.

С конца 2013 года компания активно расширяет линейку поставок компонентов по направлению коаксиальный кабель, кварцевые генераторы и конденсаторы (керамические, пленочные, электролитические), за счёт заключения дистрибьюторских договоров

Мы предлагаем:

- Конкуренспособные цены и скидки постоянным клиентам.
- Специальные условия для постоянных клиентов.
- Подбор аналогов.
- Поставку компонентов в любых объемах, удовлетворяющих вашим потребностям.
- Приемлемые сроки поставки, возможна ускоренная поставка.
- Доставку товара в любую точку России и стран СНГ.
- Комплексную поставку.
- Работу по проектам и поставку образцов.
- Формирование склада под заказчика.
- Сертификаты соответствия на поставляемую продукцию (по желанию клиента).
- Тестирование поставляемой продукции.
- Поставку компонентов, требующих военную и космическую приемку.
- Входной контроль качества.
- Наличие сертификата ISO.

В составе нашей компании организован Конструкторский отдел, призванный помогать разработчикам, и инженерам.

Конструкторский отдел помогает осуществить:

- Регистрацию проекта у производителя компонентов.
- Техническую поддержку проекта.
- Защиту от снятия компонента с производства.
- Оценку стоимости проекта по компонентам.
- Изготовление тестовой платы монтаж и пусконаладочные работы.



Тел: +7 (812) 336 43 04 (многоканальный)

Email: org@lifeelectronics.ru