

980 Ionized Air Gun Installation, Operation and Maintenance



Figure 1. SCS 980 Ionized Air Gun

The Ionized Air Gun and its accessories are available as the following item numbers:

Item	Description
980	Ionized Air Gun, with North America Power Adapter
980E	Ionized Air Gun, without Power Adapter
980-F	Air Filter, Pack of 3
980-S	Foot Switch
980-T	Emitter Tip
960X/980X	Power Adapter, 120VAC Input, 24VAC Output, North America Plug
770753	Power Adapter, 230VAC Input, 24VAC Output, UK Plug
770754	Power Adapter, 230VAC Input, 24VAC Output, Europe Plug

Description

The SCS 980 Ionized Air Gun provides efficient static charge neutralization by effectively removing particle contamination even on some of the most static-sensitive products. The SCS 980 Ionized Air Gun includes a North American power adapter. The SCS 980E Ionized Air Gun does not include a power adapter, and it must be purchased separately. All references to model 980 throughout this user's guide pertain to both of the models, unless otherwise noted.

Proprietary technology provides constantly balanced ionization for consistent control of surface charges. The Ionized Air Gun virtually never needs adjustment and requires very little maintenance.

Compact and lightweight, the console for the Ionized Air Gun can be mounted almost anywhere on the workstation for easy access. It connects to a supply of clean, dry air or nitrogen, and an internal disposable filter collects particles from the gas supply. The electrical feed from the console to the Ionized Air Gun is incorporated into the light, flexible air hose. The Ionized Air Gun itself is very lightweight and ergonomically designed for long-term user comfort and efficient operation. The console, Ionized Air Gun, and air hose are all designed to be static-dissipative and ESD-safe.

The Ionized Air Gun helps reduce a static charge of $\pm 1000V$ to $\pm 100V$ in less than 1 second at a distance of 6 inches (15 cm) and 30 psi (2 bars) inlet pressure when tested in accordance with the ESD Association ionization standard ANSI/ESD-S3.1. Balance (offset voltage) is within $\pm 30V$ at a distance of 6 inches (15 cm).

Packaging

- 1 Ionized Air Gun with Hose
- 1 Console
- 1 Console Mounting Plate
- 1 Air Filter
- 1 Power Adapter, 120VAC Input, 24VAC Output, North America Plug (980 only)
- 1 Female Quick Connect Coupling
- 1 S-Hook
- 4 Mounting Screws
- 1 Certificate of Calibration

Installation

COMPRESSED GAS REQUIREMENTS

NOTE: Failure to use clean dry air or nitrogen may result in damage to the Ionized Air Gun that is not covered under the Limited Warranty.

The compressed gas supply must be clean dry air or nitrogen supplied by a delivery system that utilizes a refrigerated dryer or equivalent water removal to achieve a line pressure limit of about 550 ppm water vapor by weight at 35°F (1.66°C) Dew Point. To prevent particles from entering the console, a 2 micron coalescing filter or better is recommended upstream of the gun console. Note that the filter in the console collects small residual particles and aerosols and does not act as a primary filter. The console filter is rated at 0.01 micron for particulates and is effective down to 0.008 micron for aerosols.

An adequate filter that can be recommended for the inlet of the Ionized Air Gun would be a Finite Filter Grade 10 Media Specification. This provides a 95% coalescing efficiency for aerosols with a 0.7 micron (and greater) particle retention. This removes gross amounts of particles, water and/or oil and aerosols.

A Grade 6 Media provides 99.98% efficiency when almost total removal of liquid aerosols and particles are required in all pressure ranges down to 0.01 microns. Fine filters need to be changed more often.

MOUNTING THE CONSOLE

Choose a location convenient to the work area and gas supply. The console takes up very little space and is adaptable to a variety of permanent or non-permanent installations. To minimize bends in the Ionized Air Gun's hose, orient the console so that the open end that accepts the filtered air hose to the hand unit points toward the work area, and the male connector points toward the gas supply.

Prior to mounting, plug the RJ-11 cable from the power supply into the jack located on the back of the console.

Use the included screws to attach the mounting plate to the threaded holes on the back of the console. Use suitable screws and fasteners to attach the mounting plate to a flat surface such as a wall or the back of a workbench. When mounting to a hollow wall, be sure to use adequate screws and wall anchors to ensure stability of the installation.

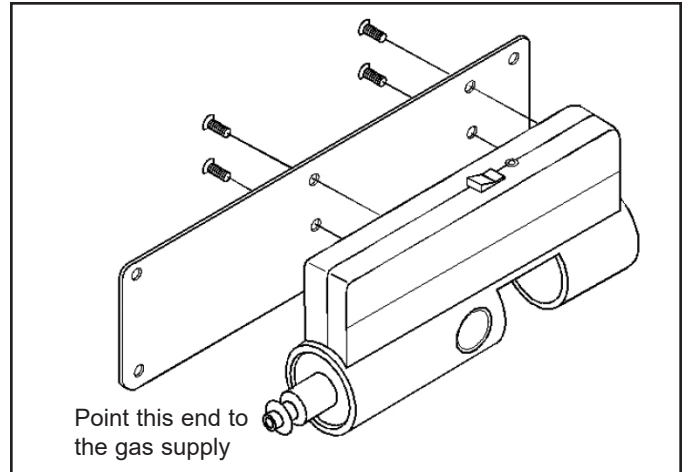

Figure 2. Securing the console to the mounting plate

MOUNTING TO A GAS SUPPLY

When a gas supply is close to the work area and fitted with a U.S. standard industrial interchange quick coupling, you may attach it to the console directly using the included female quick connect coupling. If a U.S. standard industrial interchange quick coupling is not available on the gas supply, be sure to use a suitable interconnect between the gas supply and the console. Use a prefilter as defined in the COMPRESSED GAS REQUIREMENTS section if necessary.

ASSEMBLY

NOTE: Protect the hose from sharp objects, abrasion and high temperatures. Do not pull or pinch the hose while assembling the components.

1. Insert the large end of the filter into the fitting at the end of the flexible hose. Push the filter gently until the metal release tab clicks and locks the filter into place.

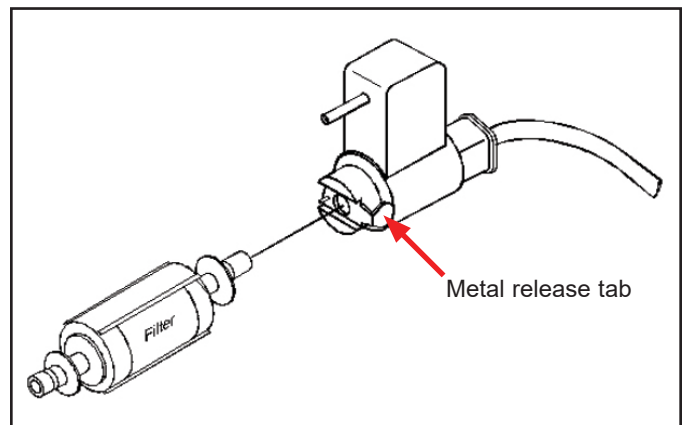

Figure 3. Connecting the air filter to the hose assembly

2. Insert the hose and filter assembly into the console until the console's release button latches on with a click. The small plastic fitting on the end of the filter must align with the metal guide coupling inside the console. You may have to wiggle the filter slightly while inserting it.

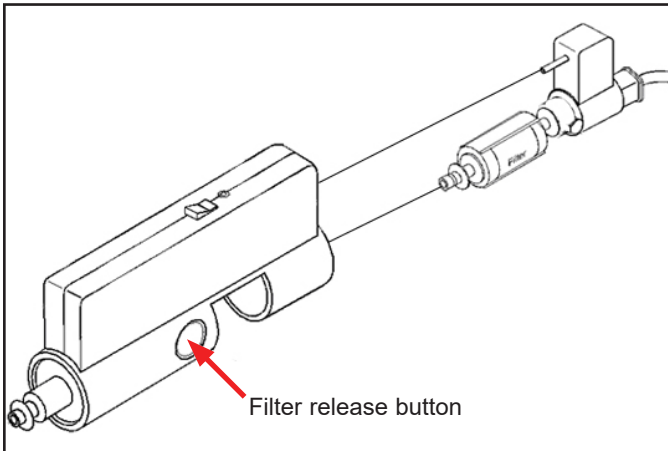

Figure 4. Inserting the hose and filter assembly into the console

3. Connect the male air inlet fitting on the console to the gas supply. The console's fitting is designed for a U.S. standard industrial interchange quick coupling. The console may be connected directly to a gas supply with the included female quick connect coupling or hose (not supplied). Use a prefilter as defined in the COMPRESSED GAS REQUIREMENTS section if necessary.
4. Connect the optional 980-S Foot Switch to the top of the console if necessary.

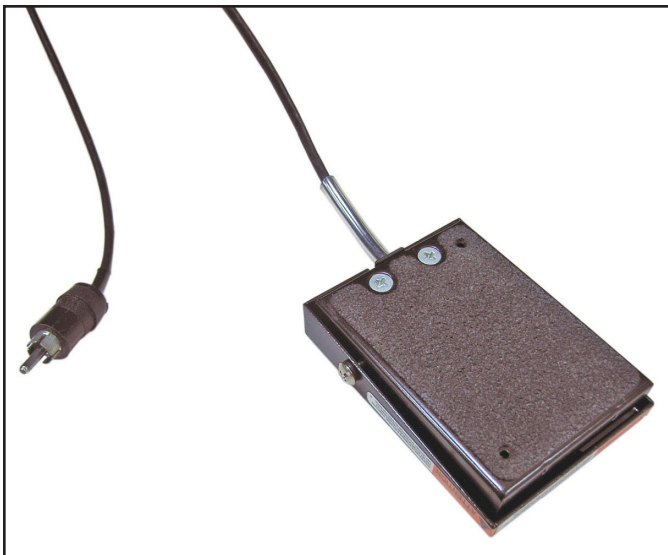

Figure 4. SCS 980-S Foot Switch

5. Use the included S-hook to hang the gun at the workstation if desired.
6. Ensure that the power switch on top of the console is in the OFF position. Connect the power adapter to an appropriate power outlet.

NOTE: Use only SCS 960X/980X, 770753 or 770754 power adapters. Use of other power adapters may result in damage to the unit and void the warranty.

For optimal safety and ionization, set the pressure regulator on the compressed gas supply to 25-65 psi (1.4-4.5 bar). Neutralization (discharge) times vary on gas pressure settings.

NOTE: Pressures of 30-40 psi (2.0-2.8 bar) are commonly used for decontaminating surfaces. Please refer to the pertinent regulations concerning maximum air pressure on hand-held air blow devices in order to determine a safe operating pressure.

The Ionized Air Gun is rated at 65 psi (4.5 bar) inlet pressure at temperatures up to 75° F (24° C), and the rating decreases at higher temperatures. When using high pressures, consider the ambient room temperature as well as heat from surrounding equipment.

Operation

1. Ensure that the gun's trigger is not depressed. Set the console's power switch to the ON position. The green power LED located next to the power switch should illuminate.
2. Aim the gun approximately 6 inches (15 cm) from the surface to be neutralized and cleaned.
3. Hold down the trigger to blow ionized air. The green LED on the back of the gun will illuminate to indicate ionization. Typically, static charges will be neutralized within one second.
4. Release the trigger when the surface is clean.

SCS recommends turning off the console whenever the Ionized Air Gun is not in use. This will prevent unintentional operation.



Figure 5. Using the Ionized Air Gun

Maintenance

The Ionized Air Gun requires very little maintenance. Occasional cleaning of the case and emitter points, and periodic replacement of the air filter are all that is required. Always be sure to protect all components from liquids and corrosive chemicals.

CAUTION: Always disconnect the Ionized Air Gun from its power and gas supplies before performing any maintenance.

CLEANING THE COMPONENTS

1. Turn off the console and disconnect it from its electrical power and gas supplies.
2. Moisten a cloth with isopropyl alcohol, and use it to wipe the exterior surfaces of the console and gun. Remove any dirt or dust that may have collected.
3. Moisten a swab with isopropyl alcohol, and use it to gently clean the emitter points in the gun. Extremely dirty points increase the time needed to neutralize static charge and affect ionization balance.

REPLACING THE AIR FILTER

SCS recommends changing the filter every three months or whenever it looks dirty. Replacement filters are available as SCS item 980-F.

1. Turn off the console and disconnect it from its electrical power and gas supplies.
2. Hold down the filter release button on the side of the console.
3. Disconnect the hose and filter assembly from the console by pulling the textured plastic ring nearby the hose's spring. Rocking the ring back and forth may help loosen the filter from the console. DO NOT pull the hose itself.

4. Pull and disconnect the filter from the hose fitting by depressing the metal release tab. Discard the dirty filter.
5. Install a new filter by following the ASSEMBLY instructions on pages 2-3.

REPLACING THE EMITTER POINTS

The emitter points are built into the gun's plastic nozzle and usually last the life of the unit. The points should only be replaced if they are broken, bent or otherwise damaged. Replacement emitter assemblies are available as SCS item 980-T.

1. Turn off the console and disconnect it from its electrical power and gas supplies.
2. Insert the tip of a screwdriver into the slot located at the bottom of the gun's nozzle.

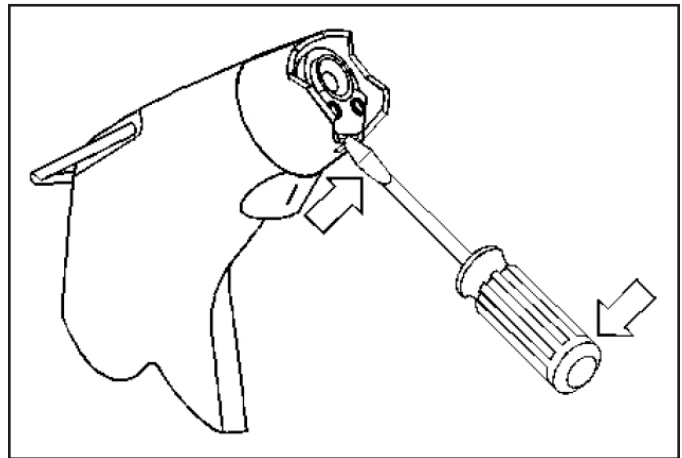

Figure 6. Inserting a screwdriver into the slot located at the bottom of the gun's nozzle

3. Use the screwdriver as a lever and loosen the old clip. Grasp it between your thumb and forefinger, and detach it from the gun. The emitter points are very sharp. Touch only the plastic lip, and handle it carefully. Do not touch the emitter points with hard objects as they may damage them.
4. To insert the new emitter points, hold the gun with the barrel pointing up. Grasp the new clip between your thumb and forefinger, and align it so the curved edges match the curve inside gun's nozzle.
5. Align the blunt prongs of the emitters with the holes inside the gun's barrel, and set the clip into place.
6. Press the clip all the way in using the tip of a screwdriver. It should fit snugly between the raised rim of the barrel and the raised rim of the air nozzle. If the clip overlaps the air nozzle, it is installed backward.

Calibration

Frequency of recalibration should be based on the critical nature of those ESD sensitive items handled and the risk of failure for the ESD protective equipment and materials. In general, SCS recommends that calibration be performed annually.

Periodically measure the balance and neutralization times of the Ionized Air Gun to verify that it is performing within specifications. These measurements should be taken using a charged plate monitor such as the SCS items 711, 770004 and 770005.

Calibration should be performed in accordance with the ESD Association ionization standard ANSI/ESD-S3.1. At a line pressure of 30 psi (2 bars) and a distance of 6 inches (15 cm), the neutralization (discharge) time of $\pm 1000V$ to $\pm 100V$ should be less than 1 second, and the balance should be $\pm 30V$ or better.



Figure 7. SCS 770004 Charged Plate Analyzer

Specifications

Input Voltage and Frequency (120VAC External Adapter)	AC Power Adapter Power Input: 120VAC, 60 Hz Power Output: 24VAC, 500mA
Input Voltage and Frequency (230VAC External Adapter)	AC Power Adapter Power Input: 230VAC, 50 Hz Power Output: 24VAC, 500mA
Neutralization (Discharge) Time at 6", 30 psi	< 1 second
Balance (Offset Voltage) at 6", 30 psi	$\pm 30V$
Power Consumption	10 W
Ion Emission	Steady-State DC
Emitter Points	Tungsten
Audible Noise at 1 m, 30 psi	70 dBA
Ozone	< 0.005 ppm
Blow-off Force	41 g @ 30 psi; measured at 3" from a 2" diameter target
Air Hose	Static-dissipative polyurethane, 3/8" outside diameter; 7' length
Gas Input	20-65 psi, Clean Dry Air (CDA) or nitrogen
Gas Connection	1/4" male industrial interchange quick disconnect
Gas Air Filter	99.9% efficient, 0.01 micron or larger air particles; 99.9% coalescing efficiency
Mounting	Metal mounting plate attaches to back of console
Enclosure	Static-dissipative polycarbonate
Dimensions (Gun)	8" x 3" x 1" (20.3 cm x 7.6 cm x 2.5 cm)
Dimensions (Console)	8.5" x 3.0" x 1.6" (21.6 cm x 7.6 cm x 4.1 cm)
Weight (Gun with Air Hose)	0.8 lbs (0.4 kg)
Weight (Console)	0.7 lbs (0.3 kg)
Certifications	cULus, CE, RoHS2
Cleanroom Class	Meets ISO 14644 Class 4 (Fed Std. 209E Class 10)
Country of Origin	China

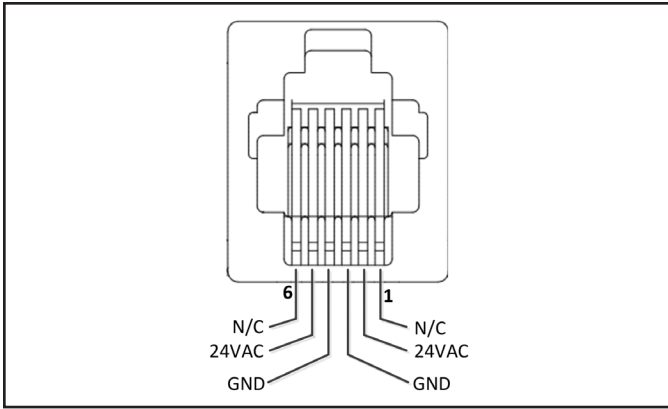

Figure 8. Pin-out of the console's power socket

cULus Statement

Meets cULus requirements .

CE Statement

ElectroMagnetic Compatibility Statement: Meets 2014-35-EU Directive.

Low Voltage: Meets 2014-30-EU Directive.

Limited Warranty, Warranty Exclusions, Limit of Liability and RMA Request Instructions

See the SCS Warranty -

StaticControl.com/Limited-Warranty.aspx

Regulatory Information

This symbol, per “Marking for the Control of Pollution Caused by Electronic Information Products, SJ/T11364-2006,” means that the product or part does not contain any substances in excess of the maximum concentration values as per “Electronic Industry Standard of the People’s Republic of China, SJ/T11363-2006, Requirements for Concentration Limits for Certain Hazardous Substances in Electronic Information Products.” This information represents SCS’s knowledge and belief, which may be based in whole or in part upon information provided by third party suppliers to SCS. In the event any product is proven not to conform with the material content-related information in this product literature, then SCS’s entire liability and Buyer’s exclusive remedy will be in accordance with the Warranty stated below. e-Waste Disposal-Recycle according to applicable local, state and federal laws for electrical/electronic waste.



RoHS 2011/65/EU Compliant means that the product or part does not contain any of the substances in excess of the maximum concentration values (“MCVs”) in EU RoHS Directive 2011/65/EU. The MCVs are by weight in homogeneous materials. This information represents SCS’s knowledge and belief, which may be based in whole or in part on information provided by third party suppliers to SCS.

WEEE Statement

The following information is only for EU-member States: The mark shown to the right is in compliance with Waste Electrical and Electronic Equipment Directive 2002/96/EC (WEEE). The mark indicates the requirement NOT to dispose the equipment as unsorted municipal waste, but use the return and collection systems according to local law.



Компания «Life Electronics» занимается поставками электронных компонентов импортного и отечественного производства от производителей и со складов крупных дистрибьюторов Европы, Америки и Азии.

С конца 2013 года компания активно расширяет линейку поставок компонентов по направлению коаксиальный кабель, кварцевые генераторы и конденсаторы (керамические, пленочные, электролитические), за счёт заключения дистрибьюторских договоров

Мы предлагаем:

- Конкурентоспособные цены и скидки постоянным клиентам.
- Специальные условия для постоянных клиентов.
- Подбор аналогов.
- Поставку компонентов в любых объемах, удовлетворяющих вашим потребностям.
- Приемлемые сроки поставки, возможна ускоренная поставка.
- Доставку товара в любую точку России и стран СНГ.
- Комплексную поставку.
- Работу по проектам и поставку образцов.
- Формирование склада под заказчика.
- Сертификаты соответствия на поставляемую продукцию (по желанию клиента).
- Тестирование поставляемой продукции.
- Поставку компонентов, требующих военную и космическую приемку.
- Входной контроль качества.
- Наличие сертификата ISO.

В составе нашей компании организован Конструкторский отдел, призванный помогать разработчикам, и инженерам.

Конструкторский отдел помогает осуществить:

- Регистрацию проекта у производителя компонентов.
- Техническую поддержку проекта.
- Защиту от снятия компонента с производства.
- Оценку стоимости проекта по компонентам.
- Изготовление тестовой платы монтаж и пусконаладочные работы.



Тел: +7 (812) 336 43 04 (многоканальный)

Email: org@lifeelectronics.ru