

FLASH-Based Microcontroller with ASK/FSK Transmitter

High Performance RISC CPU:

- Only 35 instructions to learn
 - All single cycle instructions except branches
- Operating speed:
 - Precision Internal 4 MHz oscillator, factory calibrated to $\pm 1\%$
 - DC - 20 MHz Resonator/Crystal/Clock modes
 - DC - 20 MHz crystal oscillator/clock input
 - DC - 4 MHz external RC oscillator
 - DC - 4 MHz XT crystal oscillator
 - External Oscillator modes
- Interrupt capability
- 8-level deep hardware stack
- Direct, Indirect and Relative Addressing modes

Peripheral Features:

- Memory
 - 1024 x 14 words of FLASH program memory
 - 128 x 8 bytes of EEPROM data memory
 - 64 x 8 bytes of SRAM data memory
 - 100,000 write FLASH endurance
 - 1,000,000 write EEPROM endurance
 - FLASH/data EEPROM retention: > 40 years
- Programmable code protection
- 6 I/O pins with individual direction control, weak pull-ups, and interrupt-on-pin change
- High current sink/source for direct LED drive
- Analog comparator: 16 internal reference levels
- Analog-to-Digital Converter: 10 bits, 4 channels
- Timer0: 8-bit timer/counter with 8-bit prescaler
- Timer1: 16-bit timer/counter with 3-bit prescaler
- Timer1 can use LP oscillator in INTOSC mode
- 5 μ s wake-up from SLEEP typical with $V_{DD} = 3V$
- In-Circuit Serial Programming™ (ICSP™)

Low Power Features:

- Low power consumption: (typical with $V_{DD} = 3V$)
 - 14 mA transmitting +6 dBm at 434 MHz
 - 4 mA transmitting -15 dBm at 434 MHz
 - 500 μ A, 4.0 MHz INTOSC
 - 0.6 μ A SLEEP with watchdog enabled
 - 0.1 μ A standby current
- Wide operating voltage range from 2.0 – 5.5V
- Industrial and Extended temperature range

Pin Diagram:

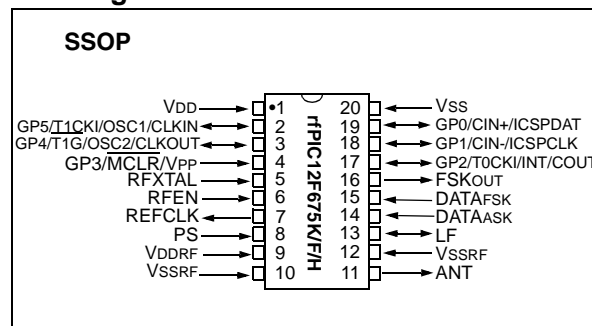

UHF ASK/FSK Transmitter:

- Integrated crystal oscillator, VCO, loop filter and power amp for minimum external components
- ASK data rate: 0 – 40 Kbps
- FSK data rate: 0 – 40 Kbps by crystal pulling
- Output power: +10 dBm to -12 dBm in 4 steps
- Adjustable transmitter power consumption
- Transmit frequency set by crystal multiplied by 32
- VCO phase locked to quartz crystal reference; allows narrow band receivers to be used to maximize range and interference immunity
- Crystal frequency divide by 4 available (REFCLK)
- Used in applications conforming to US FCC Part 15.231 and European EN 300 220 regulations

Applications:

- Automotive Remote Keyless Entry (RKE) systems
- Automotive alarm systems
- Community gate and garage door openers
- Burglar alarm systems
- Building access
- Low power telemetry
- Meter reading
- Tire pressure sensors
- Wireless sensors

Device	Frequency	Modulation
rfPIC12F675K	290-350 MHz	ASK/FSK
rfPIC12F675F	380-450 MHz	ASK/FSK
rfPIC12F675H	850-930 MHz	ASK/FSK

rfPIC12F675

Table of Contents

1.0 Device Overview	3
2.0 Memory Organization.....	5
3.0 GPIO Port	17
4.0 Timer0 Module.....	25
5.0 Timer1 Module with Gate Control.....	28
6.0 Comparator Module.....	33
7.0 Analog-to-Digital Converter (A/D) Module	39
8.0 Data EEPROM Memory.....	45
9.0 UHF ASK/FSK Transmitter.....	49
10.0 Special Features of the CPU	55
11.0 Instruction Set Summary	73
12.0 Development Support.....	81
13.0 Electrical Specifications	87
14.0 DC and AC Characteristics Graphs and Tables	113
15.0 Packaging Information	123
Appendix A: Data Sheet Revision History.....	125
Index	127
On-Line Support.....	131
Systems Information and Upgrade Hot Line	131
Reader Response	132
Product Identification System.....	133

TO OUR VALUED CUSTOMERS

It is our intention to provide our valued customers with the best documentation possible to ensure successful use of your Microchip products. To this end, we will continue to improve our publications to better suit your needs. Our publications will be refined and enhanced as new volumes and updates are introduced.

If you have any questions or comments regarding this publication, please contact the Marketing Communications Department via E-mail at docerrors@mail.microchip.com or fax the **Reader Response Form** in the back of this data sheet to (480) 792-4150. We welcome your feedback.

Most Current Data Sheet

To obtain the most up-to-date version of this data sheet, please register at our Worldwide Web site at:

<http://www.microchip.com>

You can determine the version of a data sheet by examining its literature number found on the bottom outside corner of any page. The last character of the literature number is the version number, (e.g., DS30000A is version A of document DS30000).

Errata

An errata sheet, describing minor operational differences from the data sheet and recommended workarounds, may exist for current devices. As device/documentation issues become known to us, we will publish an errata sheet. The errata will specify the revision of silicon and revision of document to which it applies.

To determine if an errata sheet exists for a particular device, please check with one of the following:

- Microchip's Worldwide Web site; <http://www.microchip.com>
- Your local Microchip sales office (see last page)
- The Microchip Corporate Literature Center; U.S. FAX: (480) 792-7277

When contacting a sales office or the literature center, please specify which device, revision of silicon and data sheet (include literature number) you are using.

Customer Notification System

Register on our web site at www.microchip.com/cn to receive the most current information on all of our products.

1.0 DEVICE OVERVIEW

This document contains device specific information for the rfPIC12F675. Additional information may be found in the *PICmicro™ Mid-Range Reference Manual* (DS33023), which may be obtained from your local Microchip Sales Representative or downloaded from the Microchip web site. The Reference Manual should

be considered a complementary document to this Data Sheet, and is highly recommended reading for a better understanding of the device architecture and operation of the peripheral modules.

The rfPIC12F675 comes in a 20-pin SSOP package. Figure 1-1 shows a block diagram of the rfPIC12F675 device. Table 1-1 shows the pinout description.

FIGURE 1-1: rfPIC12F675 BLOCK DIAGRAM

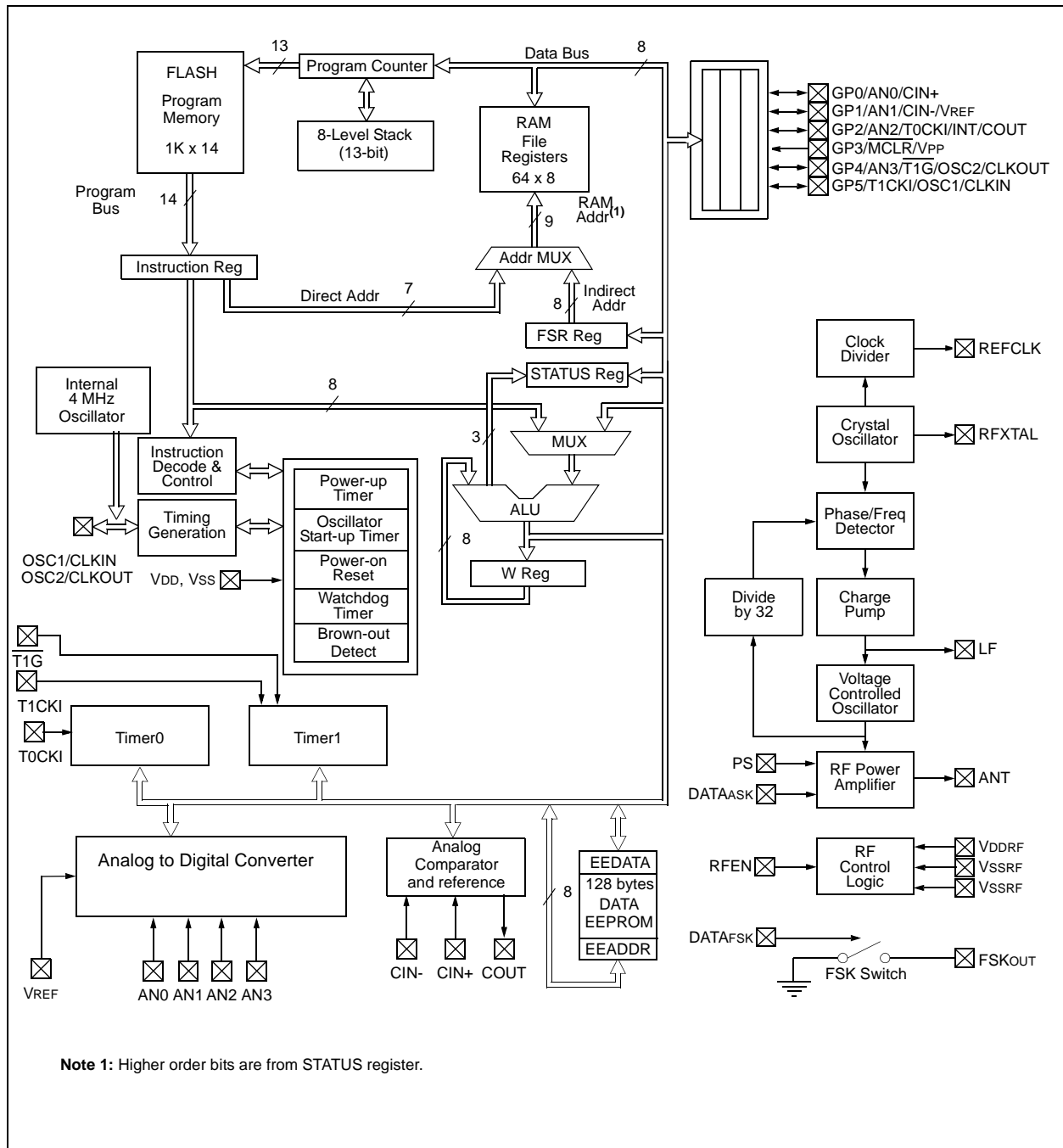

rfPIC12F675

TABLE 1-1: rfPIC12F675 PINOUT

PIN	BUFFER		WEAK PULL-UP	DESCRIPTION	
	IN	OUT			
1	VDD	Direct	—	Power Supply	
2	GP5	TTL	CMOS	Prog	General purpose I/O. Individually controlled interrupt-on-change. Individually enabled pull-up.
	T1CKI	ST	—	—	Timer1 clock
	OSC1	Xtal	—	Bias	XTAL connection
	CLKIN	ST	—	—	External RC network or clock input
3	GP4	TTL	CMOS	Prog	General purpose I/O. Individually controlled interrupt-on-change. Individually enabled pull-up.
	T1G	ST	—	—	Timer1 gate
	AN3	Analog	—	—	A/D Channel 3 input
	OSC2	—	Xtal	Bias	XTAL connection
	CLKOUT	—	CMOS	—	Tosc/4 reference clock
4	GP3	TTL	—	—	General purpose input. Individually controlled interrupt-on-change.
	MCLR	ST	—	No	Master Clear Reset
	VPP	HV	—	—	Programming voltage
5	RFXTAL	Xtal	Xtal	Bias	RF Crystal
6	RFEN	TTL	—	—	RF Enable
7	REFCLK	—	CMOS	—	Reference Clock/4 Output (on rfPIC12F675K/F) Reference Clock/8 Output (on rfPIC12F675H)
8	PS	Analog	—	Bias	Power Select
9	VDDRF	Direct	—	—	RF Power Supply
10	VSSRF	Direct	—	—	RF Ground Reference
11	ANT	—	OD	—	RF power amp output to antenna
12	VSSRF	Direct	—	—	RF Ground Reference
13	LF	Analog	Analog	—	Loop Filter
14	DATAASK	TTL	—	—	ASK modulation data
15	DATAFSK	TTL	—	—	FSK modulation data
16	FSKOUT	—	OD	—	FSK output to modulate reference crystal
17	GP2	ST	CMOS	Prog	General purpose I/O. Individually controlled interrupt-on-change. Individually enabled pull up.
	AN2	Analog	—	—	A/D Channel 2 input
	COUT	—	CMOS	—	Comparator output
	T0CKI	ST	—	—	External clock for Timer0
	INT	ST	—	—	External interrupt
18	GP1	TTL	CMOS	Prog	General purpose I/O. Individually controlled interrupt-on-change. Individually enabled pull-up.
	AN1	Analog	—	—	A/D Channel 1 input
	CIN-	Analog	—	—	Comparator input - negative
	VREF	Analog	—	—	External voltage reference
	ICSPCLK	ST	—	—	Serial programming clock
19	GP0	TTL	CMOS	Prog	General purpose I/O. Individually controlled interrupt-on-change. Individually enabled pull-up.
	AN0	Analog	—	—	A/D Channel 0 input
	CIN+	Analog	—	—	Comparator input - positive
	ICSPDAT	TTL	CMOS	—	Serial Programming Data I/O
20	Vss	Direct	—	—	Ground reference

Legend: TTL = TTL input buffer, ST = Schmitt Trigger input buffer, OD = Open Drain output

2.0 MEMORY ORGANIZATION

2.1 Program Memory Organization

The rfPIC12F675 devices have a 13-bit program counter capable of addressing an 8K x 14 program memory space. Only the first 1K x 14 (0000h - 03FFh) for the rfPIC12F675 devices is physically implemented. Accessing a location above these boundaries will cause a wrap around within the first 1K x 14 space. The RESET vector is at 0000h and the interrupt vector is at 0004h (see Figure 2-1).

FIGURE 2-1: PROGRAM MEMORY MAP AND STACK FOR THE rfPIC12F675

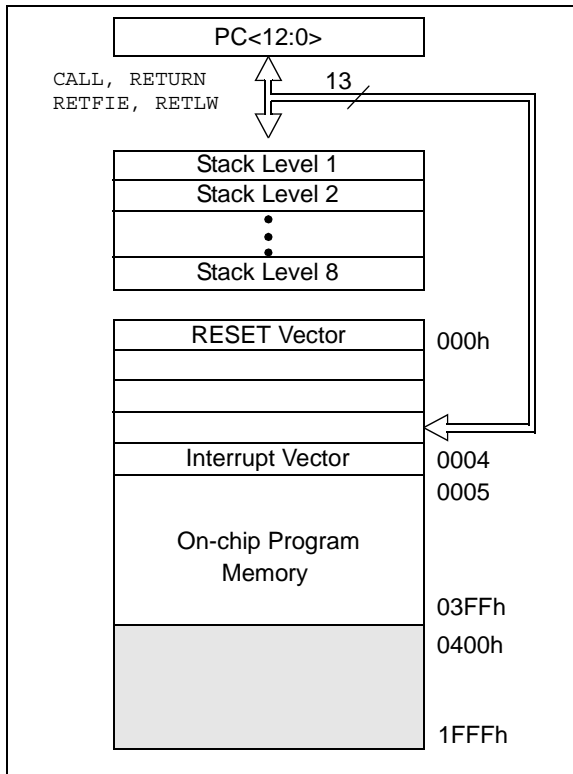

2.2 Data Memory Organization

The data memory (see Figure 2-2) is partitioned into two banks, which contain the General Purpose registers and the Special Function registers. The Special Function registers are located in the first 32 locations of each bank. Register locations 20h-5Fh are General Purpose registers, implemented as static RAM and are mapped across both banks. All other RAM is unimplemented and returns '0' when read. RP0 (STATUS<5>) is the bank select bit.

- RP0 = 0 Bank 0 is selected
- RP0 = 1 Bank 1 is selected

Note: The IRP and RP1 bits STATUS<7:6> are reserved and should always be maintained as '0's.

2.2.1 GENERAL PURPOSE REGISTER FILE

The register file is organized as 64 x 8 in the rfPIC12F675 devices. Each register is accessed, either directly or indirectly, through the File Select Register FSR (see Section 2.4).

TABLE 2-1: SPECIAL FUNCTION REGISTERS SUMMARY

Address	Name	Bit 7	Bit 6	Bit 5	Bit 4	Bit 3	Bit 2	Bit 1	Bit 0	Value on POR, BOD	Page
Bank 0											
00h	INDF ⁽¹⁾	Addressing this Location uses Contents of FSR to Address Data Memory								0000 0000	16,63
01h	TMR0	Timer0 Module's Register								xxxxx xxxxx	25
02h	PCL	Program Counter's (PC) Least Significant Byte								0000 0000	15
03h	STATUS	IRP ⁽²⁾	RP1 ⁽²⁾	RP0	\overline{TO}	\overline{PD}	Z	DC	C	0001 1xxx	9
04h	FSR	Indirect Data Memory Address Pointer								xxxxx xxxxx	16
05h	GPIO	—	—	GPIO5	GPIO4	GPIO3	GPIO2	GPIO1	GPIO0	--xx xxxxx	17
06h	—	Unimplemented								—	—
07h	—	Unimplemented								—	—
08h	—	Unimplemented								—	—
09h	—	Unimplemented								—	—
0Ah	PCLATH	—	—	—	Write Buffer for Upper 5 bits of Program Counter					---0 0000	15
0Bh	INTCON	GIE	PEIE	T0IE	INTE	GPIE	T0IF	INTF	GPIF	0000 0000	11
0Ch	PIR1	EEIF	ADIF	—	—	CMIF	—	—	TMR1IF	00-- 0--0	13
0Dh	—	Unimplemented								—	—
0Eh	TMR1L	Holding Register for the Least Significant Byte of the 16-bit Timer1								xxxxx xxxxx	28
0Fh	TMR1H	Holding Register for the Most Significant Byte of the 16-bit Timer1								xxxxx xxxxx	28
10h	T1CON	—	TMR1GE	T1CKPS1	T1CKPS0	T1OSCEN	$\overline{T1SYNC}$	TMR1CS	TMR1ON	-000 0000	30
11h	—	Unimplemented								—	—
12h	—	Unimplemented								—	—
13h	—	Unimplemented								—	—
14h	—	Unimplemented								—	—
15h	—	Unimplemented								—	—
16h	—	Unimplemented								—	—
17h	—	Unimplemented								—	—
18h	—	Unimplemented								—	—
19h	CMCON	—	COU \overline{T}	—	CINV	CIS	CM2	CM1	CM0	-0-0 0000	33
1Ah	—	Unimplemented								—	—
1Bh	—	Unimplemented								—	—
1Ch	—	Unimplemented								—	—
1Dh	—	Unimplemented								—	—
1Eh	ADRESH	Most Significant 8 bits of the Left Shifted A/D Result or 2 bits of the Right Shifted Result								xxxxx xxxxx	40
1Fh	ADCON0	ADFM	VCFG	—	—	CHS1	CHS0	$\overline{GO/DONE}$	ADON	00-- 0000	41,63

Legend: — = unimplemented locations read as '0', u = unchanged, x = unknown, α = value depends on condition, shaded = unimplemented

Note 1: This is not a physical register.

2: These bits are reserved and should always be maintained as '0'.

rfPIC12F675

TABLE 2-1: SPECIAL FUNCTION REGISTERS SUMMARY (CONTINUED)

Address	Name	Bit 7	Bit 6	Bit 5	Bit 4	Bit 3	Bit 2	Bit 1	Bit 0	Value on POR, BOD	Page
Bank 1											
80h	INDF ⁽¹⁾	Addressing this Location uses Contents of FSR to Address Data Memory								0000 0000	16,63
81h	OPTION_REG	GPPU	INTEDG	T0CS	T0SE	PSA	PS2	PS1	PS0	1111 1111	10,26
82h	PCL	Program Counter's (PC) Least Significant Byte								0000 0000	15
83h	STATUS	IRP ⁽²⁾	RP1 ⁽²⁾	RP0	T0	PD	Z	DC	C	0001 1xxx	9
84h	FSR	Indirect Data Memory Address Pointer								xxxx xxxx	16
85h	TRISIO	—	—	TRISIO5	TRISIO4	TRISIO3	TRISIO2	TRISIO1	TRISIO0	--11 1111	17
86h	—	Unimplemented								—	—
87h	—	Unimplemented								—	—
88h	—	Unimplemented								—	—
89h	—	Unimplemented								—	—
8Ah	PCLATH	—	—	—	Write Buffer for Upper 5 bits of Program Counter				---	0 0000	15
8Bh	INTCON	GIE	PEIE	T0IE	INTE	GPIE	T0IF	INTF	GPIF	0000 0000	11
8Ch	PIE1	EEIE	ADIE	—	—	CMIE	—	—	TMR1IE	00-- 0--0	12
8Dh	—	Unimplemented								—	—
8Eh	PCON	—	—	—	—	—	—	POR	BOD	---- --0x	14
8Fh	—	Unimplemented								—	—
90h	OSCCAL	CAL5	CAL4	CAL3	CAL2	CAL1	CAL0	—	—	1000 00--	14
91h	—	Unimplemented								—	—
92h	—	Unimplemented								—	—
93h	—	Unimplemented								—	—
94h	—	Unimplemented								—	—
95h	WPU	—	—	WPU5	WPU4	—	WPU2	WPU1	WPU0	--11 -111	18
96h	IOC	—	—	IOC5	IOC4	IOC3	IOC2	IOC1	IOC0	--00 0000	19
97h	—	Unimplemented								—	—
98h	—	Unimplemented								—	—
99h	VRCON	VREN	—	VRR	—	VR3	VR2	VR1	VR0	0-0- 0000	38
9Ah	EEDATA	Data EEPROM Data Register								0000 0000	45
9Bh	EEADR	—	Data EEPROM Address Register							-000 0000	45
9Ch	EECON1	—	—	—	—	WRERR	WREN	WR	RD	---- x000	46
9Dh	EECON2 ⁽¹⁾	EEPROM Control Register 2								---- ----	46
9Eh	ADRESL	Least Significant 2 bits of the Left Shifted A/D Result of 8 bits or the Right Shifted Result								xxxx xxxx	40
9Fh	ANSEL	—	ADCS2	ADCS1	ADCS0	ANS3	ANS2	ANS1	ANS0	-000 1111	42,63

Legend: — = unimplemented locations read as '0', u = unchanged, x = unknown, q = value depends on condition, shaded = unimplemented

- Note 1:** This is not a physical register.
Note 2: These bits are reserved and should always be maintained as '0'.

2.2.2.1 STATUS Register

The STATUS register, shown in Register 2-1, contains:

- the arithmetic status of the ALU
- the RESET status
- the bank select bits for data memory (SRAM)

The STATUS register can be the destination for any instruction, like any other register. If the STATUS register is the destination for an instruction that affects the Z, DC or C bits, then the write to these three bits is disabled. These bits are set or cleared according to the device logic. Furthermore, the TO and PD bits are not writable. Therefore, the result of an instruction with the STATUS register as destination may be different than intended.

For example, CLRF STATUS will clear the upper three bits and set the Z bit. This leaves the STATUS register as 000u u1uu (where u = unchanged).

It is recommended, therefore, that only BCF, BSF, SWAPF and MOVWF instructions are used to alter the STATUS register, because these instructions do not affect any STATUS bits. For other instructions not affecting any STATUS bits, see the "Instruction Set Summary".

Note 1: Bits IRP and RP1 (STATUS<7:6>) are not used by the rfPIC12F675 and should be maintained as clear. Use of these bits is not recommended, since this may affect upward compatibility with future products.

2: The C and DC bits operate as a Borrow and Digit Borrow out bit, respectively, in subtraction. See the SUBLW and SUBWF instructions for examples.

REGISTER 2-1: STATUS — STATUS REGISTER (ADDRESS: 03h OR 83h)

Reserved	Reserved	R/W-0	R-1	R-1	R/W-x	R/W-x	R/W-x
IRP	RP1	RP0	TO	PD	Z	DC	C
					bit 0		

- bit 7 **IRP:** This bit is reserved and should be maintained as '0'
- bit 6 **RP1:** This bit is reserved and should be maintained as '0'
- bit 5 **RP0:** Register Bank Select bit (used for direct addressing)
1 = Bank 1 (80h - FFh)
0 = Bank 0 (00h - 7Fh)
- bit 4 **TO:** Time-out bit
1 = After power-up, CLRWDT instruction, or SLEEP instruction
0 = A WDT time-out occurred
- bit 3 **PD:** Power-down bit
1 = After power-up or by the CLRWDT instruction
0 = By execution of the SLEEP instruction
- bit 2 **Z:** Zero bit
1 = The result of an arithmetic or logic operation is zero
0 = The result of an arithmetic or logic operation is not zero
- bit 1 **DC:** Digit carry/borrow bit (ADDWF, ADDLW, SUBLW, SUBWF instructions)
For borrow, the polarity is reversed.
1 = A carry-out from the 4th low order bit of the result occurred
0 = No carry-out from the 4th low order bit of the result
- bit 0 **C:** Carry/borrow bit (ADDWF, ADDLW, SUBLW, SUBWF instructions)
1 = A carry-out from the Most Significant bit of the result occurred
0 = No carry-out from the Most Significant bit of the result occurred

Note: For borrow the polarity is reversed. A subtraction is executed by adding the two's complement of the second operand. For rotate (RRF, RLF) instructions, this bit is loaded with either the high or low order bit of the source register

Legend:

R = Readable bit W = Writable bit U = Unimplemented bit, read as '0'
- n = Value at POR '1' = Bit is set '0' = Bit is cleared x = Bit is unknown

rfPIC12F675

2.2.2.2 OPTION Register

The OPTION register is a readable and writable register, which contains various control bits to configure:

- TMR0/WDT prescaler
- External GP2/INT interrupt
- TMR0
- Weak pull-ups on GPIO

Note: To achieve a 1:1 prescaler assignment for TMR0, assign the prescaler to the WDT by setting PSA bit to '1' (OPTION<3>). See Section 4.4.

REGISTER 2-2: OPTION_REG — OPTION REGISTER (ADDRESS: 81h)

	R/W-1	R/W-1	R/W-1	R/W-1	R/W-1	R/W-1	R/W-1	R/W-1
	GPPU	INTEDG	T0CS	T0SE	PSA	PS2	PS1	PS0
bit 7								bit 0

- bit 7 **GPPU:** GPIO Pull-up Enable bit
 1 = GPIO pull-ups are disabled
 0 = GPIO pull-ups are enabled by individual port latch values
- bit 6 **INTEDG:** Interrupt Edge Select bit
 1 = Interrupt on rising edge of GP2/INT pin
 0 = Interrupt on falling edge of GP2/INT pin
- bit 5 **T0CS:** TMR0 Clock Source Select bit
 1 = Transition on GP2/T0CKI pin
 0 = Internal instruction cycle clock (CLKOUT)
- bit 4 **T0SE:** TMR0 Source Edge Select bit
 1 = Increment on high-to-low transition on GP2/T0CKI pin
 0 = Increment on low-to-high transition on GP2/T0CKI pin
- bit 3 **PSA:** Prescaler Assignment bit
 1 = Prescaler is assigned to the WDT
 0 = Prescaler is assigned to the TIMER0 module
- bit 2-0 **PS2:PS0:** Prescaler Rate Select bits

Bit Value	TMR0 Rate	WDT Rate
000	1 : 2	1 : 1
001	1 : 4	1 : 2
010	1 : 8	1 : 4
011	1 : 16	1 : 8
100	1 : 32	1 : 16
101	1 : 64	1 : 32
110	1 : 128	1 : 64
111	1 : 256	1 : 128

Legend:

R = Readable bit	W = Writable bit	U = Unimplemented bit, read as '0'
- n = Value at POR	'1' = Bit is set	'0' = Bit is cleared x = Bit is unknown

2.2.2.3 INTCON Register

The INTCON register is a readable and writable register, which contains the various enable and flag bits for TMR0 register overflow, GPIO port change and external GP2/INT pin interrupts.

Note: Interrupt flag bits are set when an interrupt condition occurs, regardless of the state of its corresponding enable bit or the global enable bit, GIE (INTCON<7>). User software should ensure the appropriate interrupt flag bits are clear prior to enabling an interrupt.

REGISTER 2-3: INTCON — INTERRUPT CONTROL REGISTER (ADDRESS: 0Bh OR 8Bh)

R/W-0	R/W-0	R/W-0	R/W-0	R/W-0	R/W-0	R/W-0	R/W-0
GIE	PEIE	TOIE	INTE	GPIE	TOIF	INTF	GPIF

bit 7

bit 0

- bit 7 **GIE:** Global Interrupt Enable bit
1 = Enables all unmasked interrupts
0 = Disables all interrupts
- bit 6 **PEIE:** Peripheral Interrupt Enable bit
1 = Enables all unmasked peripheral interrupts
0 = Disables all peripheral interrupts
- bit 5 **TOIE:** TMR0 Overflow Interrupt Enable bit
1 = Enables the TMR0 interrupt
0 = Disables the TMR0 interrupt
- bit 4 **INTE:** GP2/INT External Interrupt Enable bit
1 = Enables the GP2/INT external interrupt
0 = Disables the GP2/INT external interrupt
- bit 3 **GPIE:** Port Change Interrupt Enable bit⁽¹⁾
1 = Enables the GPIO port change interrupt
0 = Disables the GPIO port change interrupt
- bit 2 **TOIF:** TMR0 Overflow Interrupt Flag bit⁽²⁾
1 = TMR0 register has overflowed (must be cleared in software)
0 = TMR0 register did not overflow
- bit 1 **INTF:** GP2/INT External Interrupt Flag bit
1 = The GP2/INT external interrupt occurred (must be cleared in software)
0 = The GP2/INT external interrupt did not occur
- bit 0 **GPIF:** Port Change Interrupt Flag bit
1 = When at least one of the GP5:GP0 pins changed state (must be cleared in software)
0 = None of the GP5:GP0 pins have changed state

Note 1: IOC register must also be enabled to enable an interrupt-on-change.

2: TOIF bit is set when TIMER0 rolls over. TIMER0 is unchanged on RESET and should be initialized before clearing TOIF bit.

Legend:

R = Readable bit	W = Writable bit	U = Unimplemented bit, read as '0'
- n = Value at POR	'1' = Bit is set	'0' = Bit is cleared x = Bit is unknown

rfPIC12F675

2.2.2.4 PIE1 Register

The PIE1 register contains the interrupt enable bits, as shown in Register 2-4.

Note: Bit PEIE (INTCON<6>) must be set to enable any peripheral interrupt.

REGISTER 2-4: PIE1 — PERIPHERAL INTERRUPT ENABLE REGISTER 1 (ADDRESS: 8Ch)

R/W-0	R/W-0	U-0	U-0	R/W-0	U-0	U-0	R/W-0
EEIE	ADIE	—	—	CMIE	—	—	TMR1IE
bit 7				bit 0			

- bit 7 **EEIE:** EE Write Complete Interrupt Enable bit
1 = Enables the EE write complete interrupt
0 = Disables the EE write complete interrupt
- bit 6 **ADIE:** A/D Converter Interrupt Enable bit
1 = Enables the A/D converter interrupt
0 = Disables the A/D converter interrupt
- bit 5-4 **Unimplemented:** Read as '0'
- bit 3 **CMIE:** Comparator Interrupt Enable bit
1 = Enables the comparator interrupt
0 = Disables the comparator interrupt
- bit 2-1 **Unimplemented:** Read as '0'
- bit 0 **TMR1IE:** TMR1 Overflow Interrupt Enable bit
1 = Enables the TMR1 overflow interrupt
0 = Disables the TMR1 overflow interrupt

Legend:

R = Readable bit W = Writable bit U = Unimplemented bit, read as '0'
- n = Value at POR '1' = Bit is set '0' = Bit is cleared x = Bit is unknown

2.2.2.5 PIR1 Register

The PIR1 register contains the interrupt flag bits, as shown in Register 2-5.

Note: Interrupt flag bits are set when an interrupt condition occurs, regardless of the state of its corresponding enable bit or the global enable bit, GIE (INTCON<7>). User software should ensure the appropriate interrupt flag bits are clear prior to enabling an interrupt.

REGISTER 2-5: PIR1 — PERIPHERAL INTERRUPT REGISTER 1 (ADDRESS: 0Ch)

R/W-0	R/W-0	U-0	U-0	R/W-0	U-0	U-0	R/W-0
EEIF	ADIF	—	—	CMIF	—	—	TMR1IF
bit 7				bit 0			

- bit 7 **EEIF:** EEPROM Write Operation Interrupt Flag bit
 1 = The write operation completed (must be cleared in software)
 0 = The write operation has not completed or has not been started
- bit 6 **ADIF:** A/D Converter Interrupt Flag bit
 1 = The A/D conversion is complete (must be cleared in software)
 0 = The A/D conversion is not complete
- bit 5-4 **Unimplemented:** Read as '0'
- bit 3 **CMIF:** Comparator Interrupt Flag bit
 1 = Comparator input has changed (must be cleared in software)
 0 = Comparator input has not changed
- bit 2-1 **Unimplemented:** Read as '0'
- bit 0 **TMR1IF:** TMR1 Overflow Interrupt Flag bit
 1 = TMR1 register overflowed (must be cleared in software)
 0 = TMR1 register did not overflow

Legend:

R = Readable bit	W = Writable bit	U = Unimplemented bit, read as '0'
- n = Value at POR	'1' = Bit is set	'0' = Bit is cleared x = Bit is unknown

rfPIC12F675

2.2.2.6 PCON Register

The Power Control (PCON) register contains flag bits to differentiate between a:

- Power-on Reset (POR)
- Brown-out Detect (BOD)
- Watchdog Timer Reset (WDT)
- External MCLR Reset

The PCON Register bits are shown in Register 2-6.

REGISTER 2-6: PCON — POWER CONTROL REGISTER (ADDRESS: 8Eh)

U-0	U-0	U-0	U-0	U-0	U-0	R/W-0	R/W-x
—	—	—	—	—	—	POR	BOD
bit 7						bit 0	

bit 7-2 **Unimplemented:** Read as '0'

bit 1 **POR:** Power-on Reset STATUS bit

1 = No Power-on Reset occurred

0 = A Power-on Reset occurred (must be set in software after a Power-on Reset occurs)

bit 0 **BOD:** Brown-out Detect STATUS bit

1 = No Brown-out Detect occurred

0 = A Brown-out Detect occurred (must be set in software after a Brown-out Detect occurs)

Legend:			
R = Readable bit	W = Writable bit	U = Unimplemented bit, read as '0'	
- n = Value at POR	'1' = Bit is set	'0' = Bit is cleared	x = Bit is unknown

2.2.2.7 OSCCAL Register

The Oscillator Calibration register (OSCCAL) is used to calibrate the internal 4 MHz oscillator. It contains 6 bits to adjust the frequency up or down to achieve 4 MHz.

The OSCCAL register bits are shown in Register 2-7.

REGISTER 2-7: OSCCAL — OSCILLATOR CALIBRATION REGISTER (ADDRESS: 90h)

R/W-1	R/W-0	R/W-0	R/W-0	R/W-0	R/W-0	U-0	U-0
CAL5	CAL4	CAL3	CAL2	CAL1	CAL0	—	—
bit 7						bit 0	

bit 7-2 **CAL5:CAL0:** 6-bit Signed Oscillator Calibration bits

111111 = Maximum frequency

100000 = Center frequency

000000 = Minimum frequency

bit 1-0 **Unimplemented:** Read as '0'

Legend:			
R = Readable bit	W = Writable bit	U = Unimplemented bit, read as '0'	
- n = Value at POR	'1' = Bit is set	'0' = Bit is cleared	x = Bit is unknown

2.3 PCL and PCLATH

The program counter (PC) is 13-bits wide. The low byte comes from the PCL register, which is a readable and writable register. The high byte (PC<12:8>) is not directly readable or writable and comes from PCLATH. On any RESET, the PC is cleared. Figure 2-3 shows the two situations for the loading of the PC. The upper example in Figure 2-3 shows how the PC is loaded on a write to PCL (PCLATH<4:0> → PCH). The lower example in Figure 2-3 shows how the PC is loaded during a CALL or GOTO instruction (PCLATH<4:3> → PCH).

FIGURE 2-3: LOADING OF PC IN DIFFERENT SITUATIONS

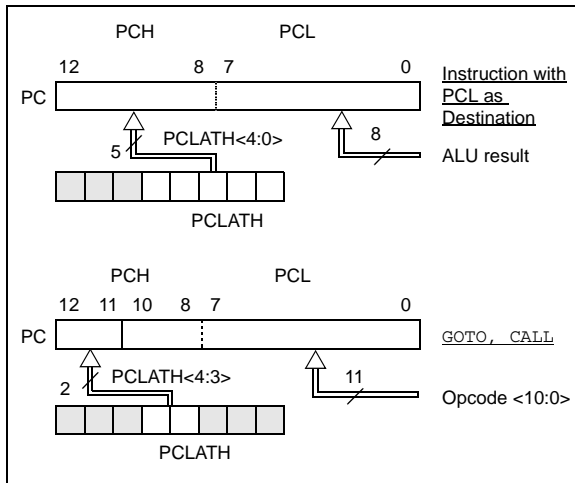

2.3.1 COMPUTED GOTO

A computed GOTO is accomplished by adding an offset to the program counter (ADDWF PCL). When performing a table read using a computed GOTO method, care should be exercised if the table location crosses a PCL memory boundary (each 256-byte block). Refer to the Application Note "Implementing a Table Read" (AN556).

2.3.2 STACK

The rfPIC12F675 Family has an 8-level deep x 13-bit wide hardware stack (see Figure 2-1). The stack space is not part of either program or data space and the stack pointer is not readable or writable. The PC is PUSHed onto the stack when a CALL instruction is executed, or an interrupt causes a branch. The stack is POPed in the event of a RETURN, RETLW or a RETFIE instruction execution. PCLATH is not affected by a PUSH or POP operation.

The stack operates as a circular buffer. This means that after the stack has been PUSHed eight times, the ninth push overwrites the value that was stored from the first push. The tenth push overwrites the second push (and so on).

Note 1: There are no STATUS bits to indicate stack overflow or stack underflow conditions.

Note 2: There are no instructions/mnemonics called PUSH or POP. These are actions that occur from the execution of the CALL, RETURN, RETLW and RETFIE instructions, or the vectoring to an interrupt address.

rfPIC12F675

2.4 Indirect Addressing, INDF and FSR Registers

The INDF register is not a physical register. Addressing the INDF register will cause indirect addressing.

Indirect addressing is possible by using the INDF register. Any instruction using the INDF register actually accesses data pointed to by the File Select register (FSR). Reading INDF itself indirectly will produce 00h. Writing to the INDF register indirectly results in a no operation (although STATUS bits may be affected). An effective 9-bit address is obtained by concatenating the 8-bit FSR register and the IRP bit (STATUS<7>), as shown in Figure 2-4.

A simple program to clear RAM location 20h-2Fh using indirect addressing is shown in Example 2-1.

EXAMPLE 2-1: INDIRECT ADDRESSING

```

movlw 0x20 ;initialize pointer
movwf FSR ;to RAM
NEXT   clrf INDF ;clear INDF register
       incf FSR ;inc pointer
       btfss FSR,4 ;all done?
       goto NEXT ;no clear next
CONTINUE ;yes continue
    
```

FIGURE 2-4: DIRECT/INDIRECT ADDRESSING rfPIC12F675

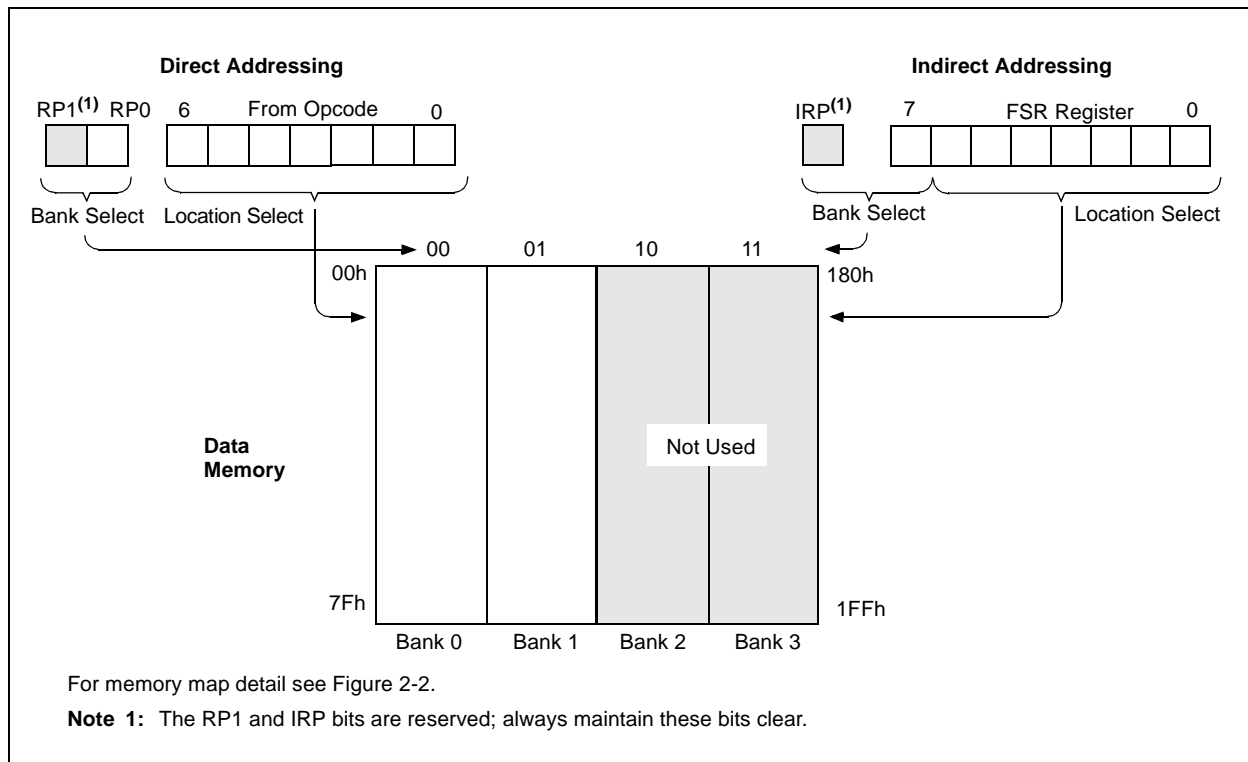

3.0 GPIO PORT

There are as many as six general purpose I/O pins available. Depending on which peripherals are enabled, some or all of the pins may not be available as general purpose I/O. In general, when a peripheral is enabled, the associated pin may not be used as a general purpose I/O pin.

Note: Additional information on I/O ports may be found in the *PIC Mid-Range Reference Manual* (DS33023)

3.1 GPIO and the TRISIO Registers

GPIO is an 6-bit wide, bi-directional port. The corresponding data direction register is TRISIO. Setting a TRISIO bit (= 1) will make the corresponding GPIO pin an input (i.e., put the corresponding output driver in a Hi-impedance mode). Clearing a TRISIO bit (= 0) will make the corresponding GPIO pin an output (i.e., put the contents of the output latch on the selected pin). The exception is GP3, which is input only and its TRISIO bit will always read as '1'. Example 3-1 shows how to initialize GPIO.

Reading the GPIO register reads the status of the pins, whereas writing to it will write to the port latch. All write operations are read-modify-write operations. Therefore, a write to a port implies that the port pins are read, this value is modified, and then written to the port data latch. GP3 reads '0' when MCLREN = 1.

The TRISIO register controls the direction of the GP pins, even when they are being used as analog inputs. The user must ensure the bits in the TRISIO

register are maintained set when using them as analog inputs. I/O pins configured as analog inputs always read '0'.

Note: The ANSEL (9Fh) and CMCON (19h) registers (9Fh) must be initialized to configure an analog channel as a digital input. Pins configured as analog inputs will read '0'.

EXAMPLE 3-1: INITIALIZING GPIO

```
bcf    STATUS,RP0    ;Bank 0
clrf   GPIO          ;Init GPIO
movlw  07h           ;Set GP<2:0> to
movwf  CMCON         ;digital IO
bsf    STATUS,RP0    ;Bank 1
clrf   ANSEL         ;Digital I/O
movlw  0Ch           ;Set GP<3:2> as inputs
movwf  TRISIO        ;and set GP<5:4,1:0>
                               ;as outputs
```

3.2 Additional Pin Functions

Every GPIO pin on the rfPIC12F675 has an interrupt-on-change option and every GPIO pin, except GP3, has a weak pull-up option. The next two sections describe these functions.

3.2.1 WEAK PULL-UP

Each of the GPIO pins, except GP3, has an individually configurable weak internal pull-up. Control bits WPUX enable or disable each pull-up. Refer to Register 3-3. Each weak pull-up is automatically turned off when the port pin is configured as an output. The pull-ups are disabled on a Power-on Reset by the GPPU bit (OPTION<7>).

REGISTER 3-1: GPIO — GPIO REGISTER (ADDRESS: 05h)

U-0	U-0	R/W-x	R/W-x	R/W-x	R/W-x	R/W-x	R/W-x	
—	—	GPIO5	GPIO4	GPIO3	GPIO2	GPIO1	GPIO0	
bit 7								bit 0

bit 7-6: **Unimplemented:** Read as '0'
 bit 5-0: **GPIO<5:0>:** General Purpose I/O pin.
 1 = Port pin is >V_{IH}
 0 = Port pin is <V_{IL}

Legend:
 R = Readable bit W = Writable bit U = Unimplemented bit, read as '0'
 - n = Value at POR '1' = Bit is set '0' = Bit is cleared x = Bit is unknown

rfPIC12F675

REGISTER 3-2: TRISIO — GPIO TRISTATE REGISTER (ADDRESS: 85h)

U-0	U-0	R/W-x	R/W-x	R-1	R/W-x	R/W-x	R/W-x	
—	—	TRISIO5	TRISIO4	TRISIO3	TRISIO2	TRISIO1	TRISIO0	
bit 7								bit 0

bit 7-6: **Unimplemented:** Read as '0'

bit 5-0: **TRISIO<5:0>**: General Purpose I/O Tri-State Control bit
 1 = GPIO pin configured as an input (tri-stated)
 0 = GPIO pin configured as an output.

Note: TRISIO<3> always reads 1.

Legend:			
R = Readable bit	W = Writable bit	U = Unimplemented bit, read as '0'	
- n = Value at POR	'1' = Bit is set	'0' = Bit is cleared	x = Bit is unknown

REGISTER 3-3: WPU — WEAK PULL-UP REGISTER (ADDRESS: 95h)

U-0	U-0	R/W-1	R/W-1	U-0	R/W-1	R/W-1	R/W-1	
—	—	WPU5	WPU4	—	WPU2	WPU1	WPU0	
bit 7								bit 0

bit 7-6: **Unimplemented:** Read as '0'

bit 5-4: **WPU<5:4>**: Weak Pull-up Register bit
 1 = Pull-up enabled
 0 = Pull-up disabled

bit 3: **Unimplemented:** Read as '0'

bit 2-0: **WPU<2:0>**: Weak Pull-up Register bit
 1 = Pull-up enabled
 0 = Pull-up disabled

Note 1: Global $\overline{\text{GPPU}}$ must be enabled for individual pull-ups to be enabled.
Note 2: The weak pull-up device is automatically disabled if the pin is in Output mode (TRISIO = 0).

Legend:			
R = Readable bit	W = Writable bit	U = Unimplemented bit, read as '0'	
- n = Value at POR	'1' = Bit is set	'0' = Bit is cleared	x = Bit is unknown

3.2.2 INTERRUPT-ON-CHANGE

Each of the GPIO pins is individually configurable as an interrupt-on-change pin. Control bits IOC enable or disable the interrupt function for each pin. Refer to Register 3-4. The interrupt-on-change is disabled on a Power-on Reset.

For enabled interrupt-on-change pins, the values are compared with the old value latched on the last read of GPIO. The 'mismatch' outputs of the last read are OR'd together to set, the GP Port Change Interrupt flag bit (GPIF) in the INTCON register.

This interrupt can wake the device from SLEEP. The user, in the Interrupt Service Routine, can clear the interrupt in the following manner:

- a) Any read or write of GPIO. This will end the mismatch condition.
- b) Clear the flag bit GPIF.

A mismatch condition will continue to set flag bit GPIF. Reading GPIO will end the mismatch condition and allow flag bit GPIF to be cleared.

Note: If a change on the I/O pin should occur when the read operation is being executed (start of the Q2 cycle), then the GPIF interrupt flag may not get set.

REGISTER 3-4: IOC — INTERRUPT-ON-CHANGE GPIO REGISTER (ADDRESS: 96h)

U-0	U-0	R/W-0	R/W-0	R/W-0	R/W-0	R/W-0	R/W-0	
—	—	IOC5	IOC4	IOC3	IOC2	IOC1	IOC0	
bit 7								bit 0

bit 7-6 **Unimplemented:** Read as '0'

bit 5-0 **IOC<5:0>:** Interrupt-on-Change GPIO Control bit
 1 = Interrupt-on-change enabled
 0 = Interrupt-on-change disabled

Note 1: Global interrupt enable (GIE) must be enabled for individual interrupts to be recognized.

Legend:

R = Readable bit	W = Writable bit	U = Unimplemented bit, read as '0'
- n = Value at POR	'1' = Bit is set	'0' = Bit is cleared x = Bit is unknown

3.3 Pin Descriptions and Diagrams

Each GPIO pin is multiplexed with other functions. The pins and their combined functions are briefly described here. For specific information about individual functions such as the comparator or the A/D, refer to the appropriate section in this Data Sheet.

3.3.1 GP0/AN0/CIN+

Figure 3-1 shows the diagram for this pin. The GP0 pin is configurable to function as one of the following:

- a general purpose I/O
- an analog input for the A/D
- an analog input to the comparator

3.3.2 GP1/AN1/CIN-/VREF

Figure 3-1 shows the diagram for this pin. The GP1 pin is configurable to function as one of the following:

- as a general purpose I/O
- an analog input for the A/D
- an analog input to the comparator
- a voltage reference input for the A/D

FIGURE 3-1: BLOCK DIAGRAM OF GP0 AND GP1 PINS

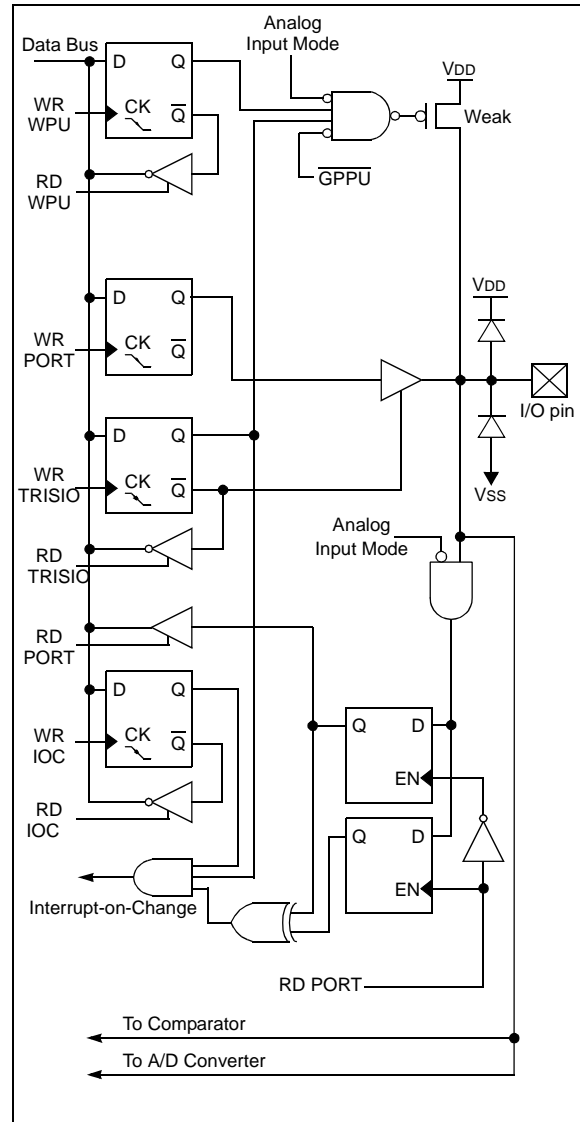

3.3.3 GP2/AN2/T0CKI/INT/COUT

Figure 3-2 shows the diagram for this pin. The GP2 pin is configurable to function as one of the following:

- a general purpose I/O
- an analog input for the A/D
- the clock input for TMR0
- an external edge triggered interrupt
- a digital output from the comparator

FIGURE 3-2: BLOCK DIAGRAM OF GP2

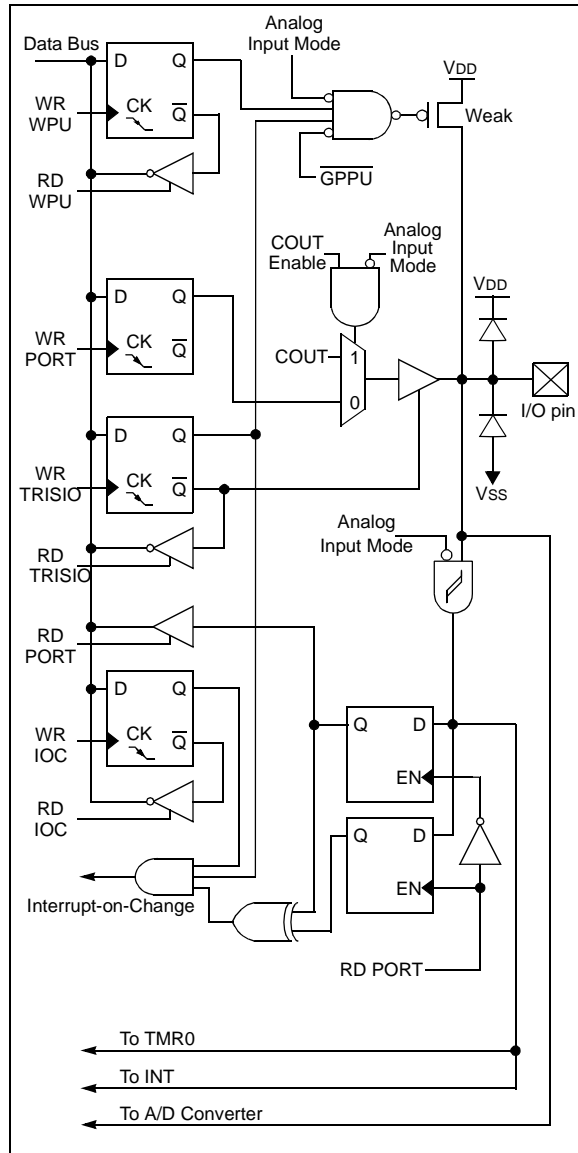

3.3.4 GP3/ $\overline{\text{MCLR}}$ /VPP

Figure 3-3 shows the diagram for this pin. The GP3 pin is configurable to function as one of the following:

- a general purpose input
- as Master Clear Reset

FIGURE 3-3: BLOCK DIAGRAM OF GP3

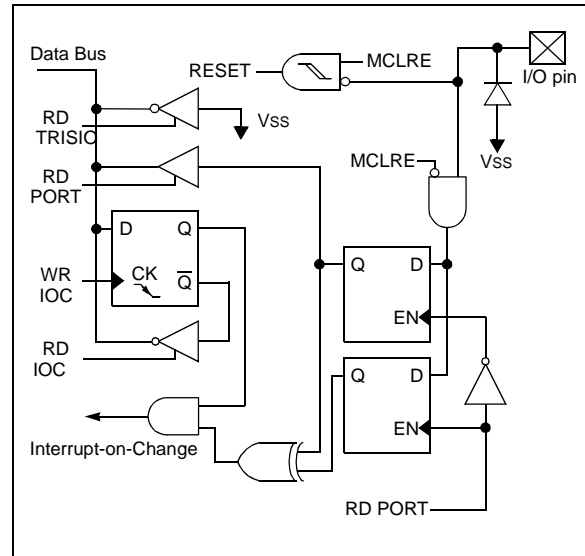

rfPIC12F675

3.3.5 GP4/AN3/T1G/OSC2/CLKOUT

Figure 3-4 shows the diagram for this pin. The GP4 pin is configurable to function as one of the following:

- a general purpose I/O
- an analog input for the A/D
- a TMR1 gate input
- a crystal/resonator connection
- a clock output

FIGURE 3-4: BLOCK DIAGRAM OF GP4

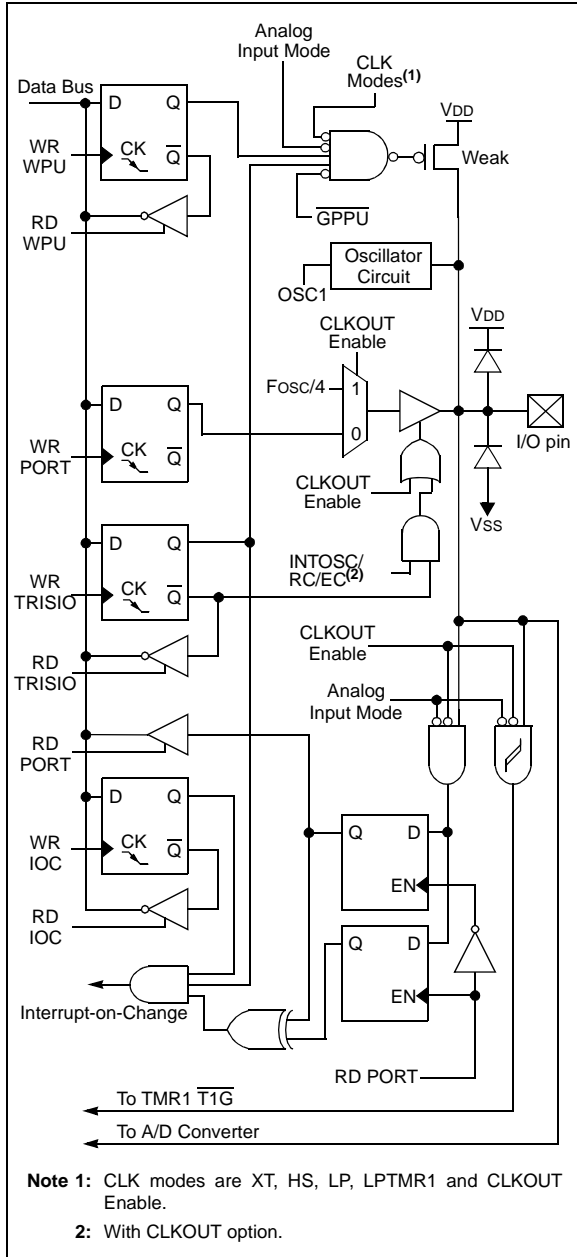

3.3.6 GP5/T1CKI/OSC1/CLKIN

Figure 3-5 shows the diagram for this pin. The GP5 pin is configurable to function as one of the following:

- a general purpose I/O
- a TMR1 clock input
- a crystal/resonator connection
- a clock input

FIGURE 3-5: BLOCK DIAGRAM OF GP5

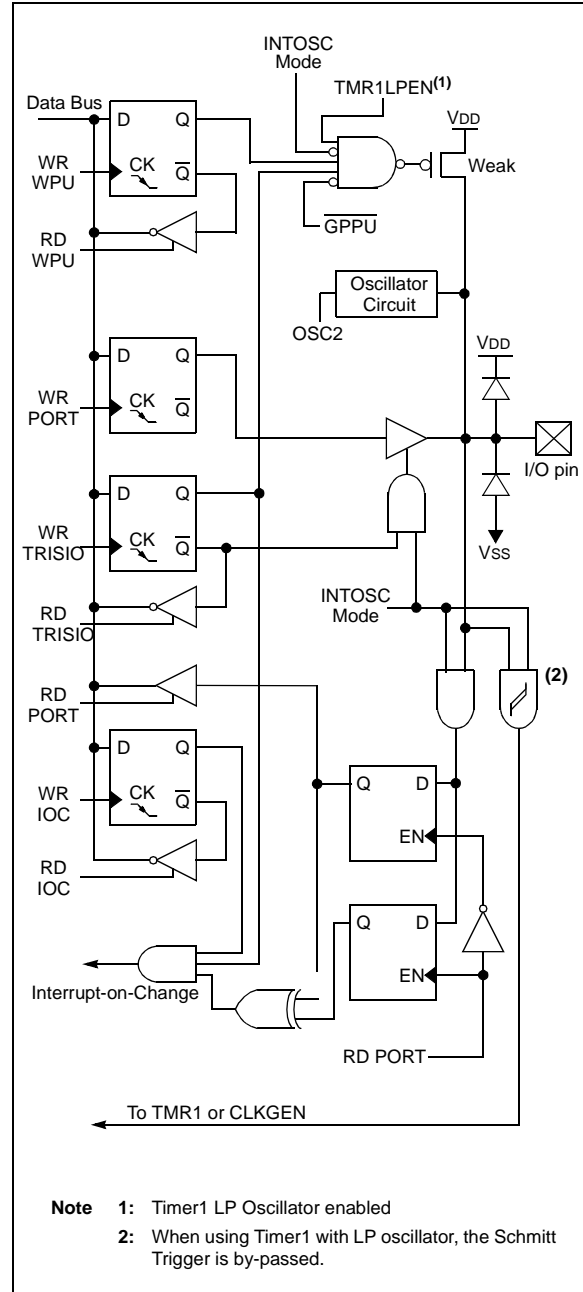

TABLE 3-1: SUMMARY OF REGISTERS ASSOCIATED WITH GPIO

Address	Name	Bit 7	Bit 6	Bit 5	Bit 4	Bit 3	Bit 2	Bit 1	Bit 0	Value on: POR, BOD	Value on all other RESETS
05h	GPIO	—	—	GP5	GP4	GP3	GP2	GP1	GP0	--xx xxxx	--uu uuuu
0Bh/8Bh	INTCON	GIE	PEIE	T0IE	INTE	GPIE	T0IF	INTF	GPIF	0000 0000	0000 000u
19h	CMCON	—	COUT	—	CINV	CIS	CM2	CM1	CM0	-0-0 0000	-0-0 0000
81h	OPTION_REG	GPPU	INTEDG	T0CS	T0SE	PSA	PS2	PS1	PS0	1111 1111	1111 1111
85h	TRISIO	—	—	TRISIO5	TRISIO4	TRISIO3	TRISIO2	TRISIO1	TRISIO0	--11 1111	--11 1111
95h	WPU	—	—	WPU5	WPU4	—	WPU2	WPU1	WPU0	--11 -111	--11 -111
96h	IOC	—	—	IOC5	IOC4	IOC3	IOC2	IOC1	IOC0	--00 0000	--00 0000
9Fh	ANSEL	—	ADCS2	ADCS1	ADCS0	ANS3	ANS2	ANS1	ANS0	-000 1111	-000 1111

Legend: x = unknown, u = unchanged, - = unimplemented locations read as '0'. Shaded cells are not used by GPIO.

rfPIC12F675

NOTES:

4.0 TIMER0 MODULE

The Timer0 module timer/counter has the following features:

- 8-bit timer/counter
- Readable and writable
- 8-bit software programmable prescaler
- Internal or external clock select
- Interrupt on overflow from FFh to 00h
- Edge select for external clock

Figure 4-1 is a block diagram of the Timer0 module and the prescaler shared with the WDT.

Note: Additional information on the Timer0 module is available in the *PICmicro™ Mid-Range Reference Manual (DS33023)*.

4.1 Timer0 Operation

Timer mode is selected by clearing the T0CS bit (OPTION_REG<5>). In Timer mode, the Timer0 module will increment every instruction cycle (without prescaler). If TMR0 is written, the increment is inhibited for the following two instruction cycles. The user can work around this by writing an adjusted value to the TMR0 register.

Counter mode is selected by setting the T0CS bit (OPTION_REG<5>). In this mode, the Timer0 module will increment either on every rising or falling edge of pin GP2/T0CKI. The incrementing edge is determined by the source edge (T0SE) control bit (OPTION_REG<4>). Clearing the T0SE bit selects the rising edge.

Note: Counter mode has specific external clock requirements. Additional information on these requirements is available in the *PICmicro™ Mid-Range Reference Manual (DS33023)*.

4.2 Timer0 Interrupt

A Timer0 interrupt is generated when the TMR0 register timer/counter overflows from FFh to 00h. This overflow sets the TOIF bit. The interrupt can be masked by clearing the TOIE bit (INTCON<5>). The TOIF bit (INTCON<2>) must be cleared in software by the Timer0 module Interrupt Service Routine before re-enabling this interrupt. The Timer0 interrupt cannot wake the processor from SLEEP since the timer is shut-off during SLEEP.

FIGURE 4-1: BLOCK DIAGRAM OF THE TIMER0/WDT PRESCALER

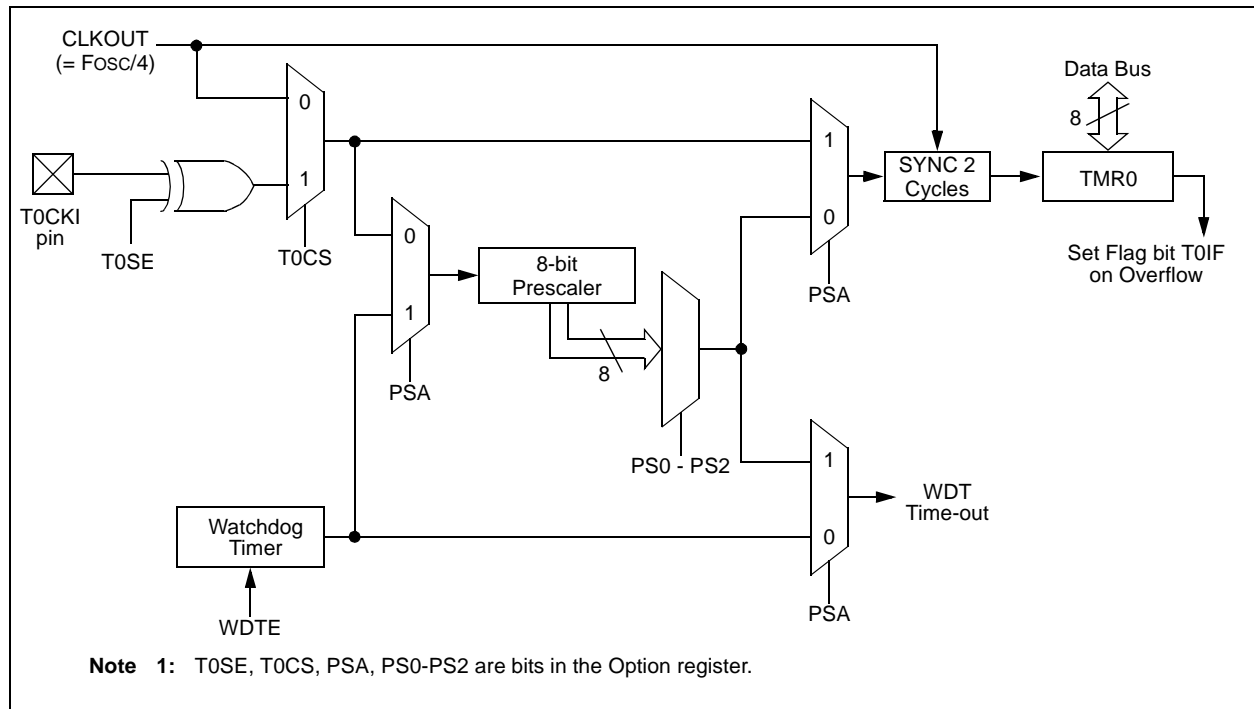

rfPIC12F675

4.3 Using Timer0 with an External Clock

When no prescaler is used, the external clock input is the same as the prescaler output. The synchronization of T0CKI, with the internal phase clocks, is accomplished by sampling the prescaler output on the Q2 and Q4 cycles of the internal phase clocks. Therefore, it is necessary for T0CKI to be high for at least 2Tosc (and

a small RC delay of 20 ns) and low for at least 2Tosc (and a small RC delay of 20 ns). Refer to the electrical specification of the desired device.

Note: The ANSEL (9Fh) and CMCON (19h) registers must be initialized to configure an analog channel as a digital input. Pins configured as analog inputs will read '0'.

REGISTER 4-1: OPTION_REG — OPTION REGISTER (ADDRESS: 81h)

R/W-1	R/W-1	R/W-1	R/W-1	R/W-1	R/W-1	R/W-1	R/W-1
GPPU	INTEDG	T0CS	T0SE	PSA	PS2	PS1	PS0
bit 7						bit 0	

- bit 7 **GPPU:** GPIO Pull-up Enable bit
1 = GPIO pull-ups are disabled
0 = GPIO pull-ups are enabled by individual port latch values
- bit 6 **INTEDG:** Interrupt Edge Select bit
1 = Interrupt on rising edge of GP2/INT pin
0 = Interrupt on falling edge of GP2/INT pin
- bit 5 **T0CS:** TMR0 Clock Source Select bit
1 = Transition on GP2/T0CKI pin
0 = Internal instruction cycle clock (CLKOUT)
- bit 4 **T0SE:** TMR0 Source Edge Select bit
1 = Increment on high-to-low transition on GP2/T0CKI pin
0 = Increment on low-to-high transition on GP2/T0CKI pin
- bit 3 **PSA:** Prescaler Assignment bit
1 = Prescaler is assigned to the WDT
0 = Prescaler is assigned to the TIMER0 module
- bit 2-0 **PS2:PS0:** Prescaler Rate Select bits

Bit Value	TMR0 Rate	WDT Rate
000	1 : 2	1 : 1
001	1 : 4	1 : 2
010	1 : 8	1 : 4
011	1 : 16	1 : 8
100	1 : 32	1 : 16
101	1 : 64	1 : 32
110	1 : 128	1 : 64
111	1 : 256	1 : 128

Legend:
 R = Readable bit W = Writable bit U = Unimplemented bit, read as '0'
 - n = Value at POR '1' = Bit is set '0' = Bit is cleared x = Bit is unknown

4.4 Prescaler

An 8-bit counter is available as a prescaler for the Timer0 module, or as a postscaler for the Watchdog Timer. For simplicity, this counter will be referred to as “prescaler” throughout this Data Sheet. The prescaler assignment is controlled in software by the control bit PSA (OPTION_REG<3>). Clearing the PSA bit will assign the prescaler to Timer0. Prescale values are selectable via the PS2:PS0 bits (OPTION_REG<2:0>).

The prescaler is not readable or writable. When assigned to the Timer0 module, all instructions writing to the TMR0 register (e.g., CLRF 1, MOVWF 1, BSF 1, x...etc.) will clear the prescaler. When assigned to WDT, a CLRWDT instruction will clear the prescaler along with the Watchdog Timer.

4.4.1 SWITCHING PRESCALER ASSIGNMENT

The prescaler assignment is fully under software control (i.e., it can be changed “on the fly” during program execution). To avoid an unintended device RESET, the following instruction sequence (Example 4-1) must be executed when changing the prescaler assignment from Timer0 to WDT.

EXAMPLE 4-1: CHANGING PRESCALER (TIMER0→WDT)

```

bcf    STATUS,RP0    ;Bank 0
clrwdt                ;Clear WDT
clrf   TMR0          ;Clear TMR0 and
                    ; prescaler
bsf    STATUS,RP0    ;Bank 1

movlw  b'00101111'   ;Required if desired
movwf  OPTION_REG    ; PS2:PS0 is
clrwdt                ; 000 or 001
                    ;
movlw  b'00101xxx'   ;Set postscaler to
movwf  OPTION_REG    ; desired WDT rate
bcf    STATUS,RP0    ;Bank 0
    
```

To change prescaler from the WDT to the TMR0 module, use the sequence shown in Example 4-2. This precaution must be taken even if the WDT is disabled.

EXAMPLE 4-2: CHANGING PRESCALER (WDT→TIMER0)

```

clrwdt                ;Clear WDT and
                    ; postscaler
bsf    STATUS,RP0    ;Bank 1

movlw  b'xxxx0xxx'   ;Select TMR0,
                    ; prescale, and
                    ; clock source
movwf  OPTION_REG    ;
bcf    STATUS,RP0    ;Bank 0
    
```

TABLE 4-1: REGISTERS ASSOCIATED WITH TIMER0

Address	Name	Bit 7	Bit 6	Bit 5	Bit 4	Bit 3	Bit 2	Bit 1	Bit 0	Value on POR, BOD	Value on all other RESETS
01h	TMR0	Timer0 Module Register								xxxx xxxx	uuuu uuuu
0Bh/8Bh	INTCON	GIE	PEIE	TOIE	INTE	GPIE	T0IF	INTF	GPIF	0000 0000	0000 000u
81h	OPTION_REG	GPPU	INTEDG	TOCS	T0SE	PSA	PS2	PS1	PS0	1111 1111	1111 1111
85h	TRISIO	—	—	TRISIO5	TRISIO4	TRISIO3	TRISIO2	TRISIO1	TRISIO0	--11 1111	--11 1111

Legend: — = Unimplemented locations, read as '0', u = unchanged, x = unknown.
Shaded cells are not used by the Timer0 module.

rfPIC12F675

5.0 TIMER1 MODULE WITH GATE CONTROL

The rfPIC12F675 devices have a 16-bit timer. Figure 5-1 shows the basic block diagram of the Timer1 module. Timer1 has the following features:

- 16-bit timer/counter (TMR1H:TMR1L)
- Readable and writable
- Internal or external clock selection
- Synchronous or asynchronous operation
- Interrupt on overflow from FFFFh to 0000h
- Wake-up upon overflow (Asynchronous mode)
- Optional external enable input ($\overline{T1G}$)
- Optional LP oscillator

The Timer1 Control register (T1CON), shown in Register 5-1, is used to enable/disable Timer1 and select the various features of the Timer1 module.

Note: Additional information on timer modules is available in the *PICmicro™ Mid-Range Reference Manual (DS33023)*.

FIGURE 5-1: TIMER1 BLOCK DIAGRAM

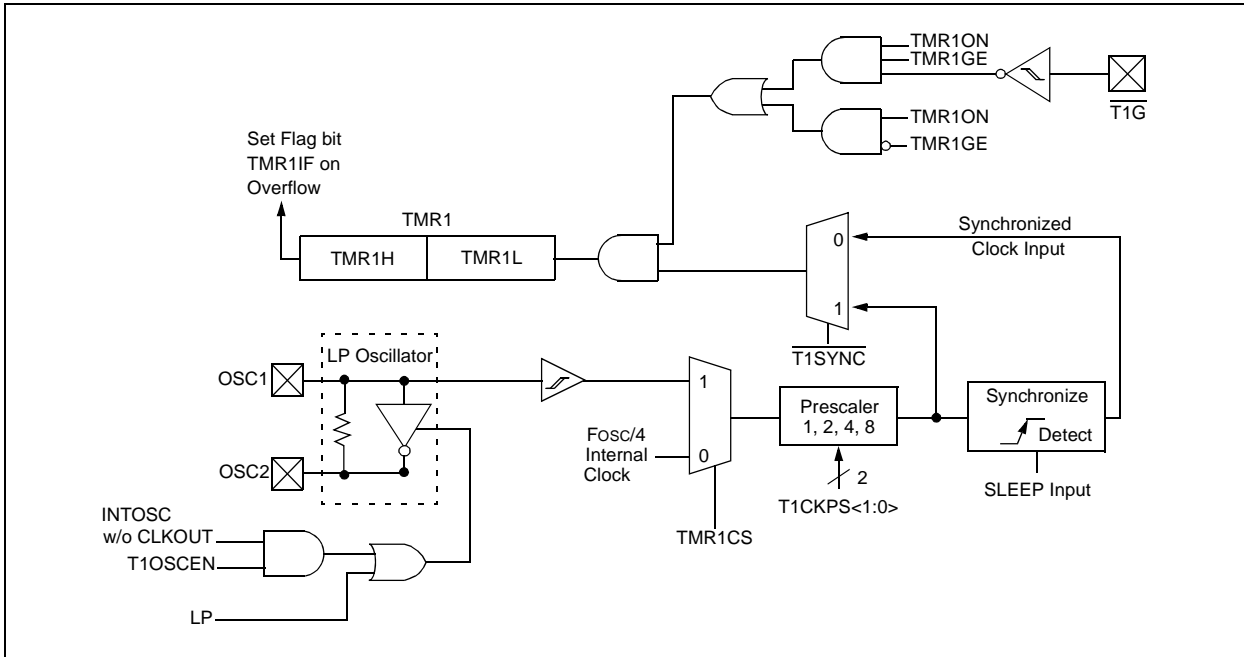

5.1 Timer1 Modes of Operation

Timer1 can operate in one of three modes:

- 16-bit timer with prescaler
- 16-bit synchronous counter
- 16-bit asynchronous counter

In Timer mode, Timer1 is incremented on every instruction cycle. In Counter mode, Timer1 is incremented on the rising edge of the external clock input T1CKI. In addition, the Counter mode clock can be synchronized to the microcontroller system clock or run asynchronously.

In Counter and Timer modules, the counter/timer clock can be gated by the T1G input.

If an external clock oscillator is needed (and the microcontroller is using the INTOSC w/o CLKOUT), Timer1 can use the LP oscillator as a clock source.

Note: In Counter mode, a falling edge must be registered by the counter prior to the first incrementing rising edge.

5.2 Timer1 Interrupt

The Timer1 register pair (TMR1H:TMR1L) increments to FFFFh and rolls over to 0000h. When Timer1 rolls over, the Timer1 interrupt flag bit (PIR1<0>) is set. To enable the interrupt on rollover, you must set these bits:

- Timer1 interrupt Enable bit (PIE1<0>)
- PEIE bit (INTCON<6>)
- GIE bit (INTCON<7>).

The interrupt is cleared by clearing the TMR1IF in the Interrupt Service Routine.

Note: The TMR1H:TMR1L register pair and the TMR1IF bit should be cleared before enabling interrupts.

5.3 Timer1 Prescaler

Timer1 has four prescaler options allowing 1, 2, 4, or 8 divisions of the clock input. The T1CKPS bits (T1CON<5:4>) control the prescale counter. The prescale counter is not directly readable or writable; however, the prescaler counter is cleared upon a write to TMR1H or TMR1L.

FIGURE 5-2: TIMER1 INCREMENTING EDGE

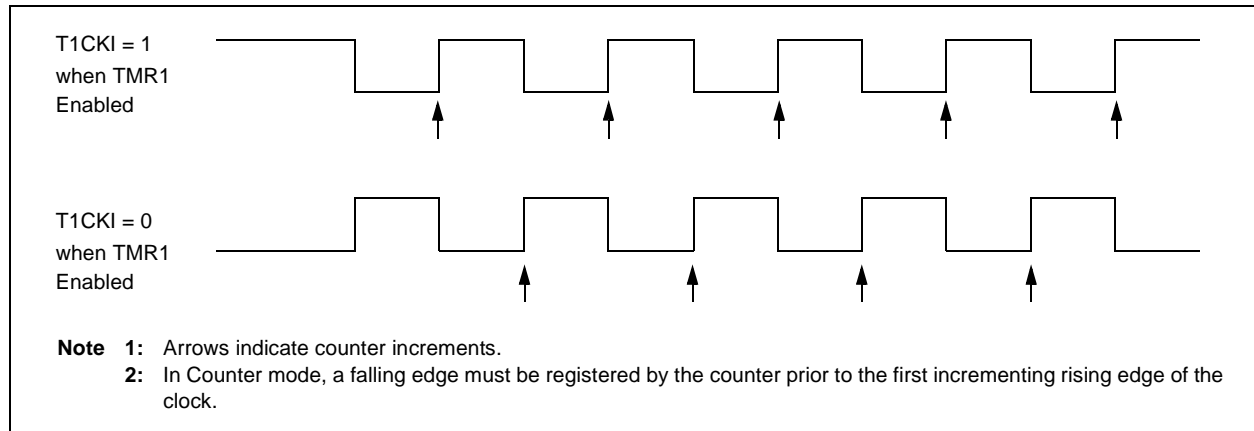

rfPIC12F675

REGISTER 5-1: T1CON — TIMER1 CONTROL REGISTER (ADDRESS: 10h)

U-0	R/W-0	R/W-0	R/W-0	R/W-0	R/W-0	R/W-0	R/W-0
—	TMR1GE	T1CKPS1	T1CKPS0	T1OSCEN	$\overline{T1SYNC}$	TMR1CS	TMR1ON
bit 7							bit 0

- bit 7 **Unimplemented:** Read as '0'
- bit 6 **TMR1GE:** Timer1 Gate Enable bit
 If **TMR1ON = 0:**
 This bit is ignored
 If **TMR1ON = 1:**
 1 = Timer1 is on if $\overline{T1G}$ pin is low
 0 = Timer1 is on
- bit 5-4 **T1CKPS1:T1CKPS0:** Timer1 Input Clock Prescale Select bits
 11 = 1:8 Prescale Value
 10 = 1:4 Prescale Value
 01 = 1:2 Prescale Value
 00 = 1:1 Prescale Value
- bit 3 **T1OSCEN:** LP Oscillator Enable Control bit
 If INTOSC without CLKOUT oscillator is active:
 1 = LP oscillator is enabled for Timer1 clock
 0 = LP oscillator is off
 Else:
 This bit is ignored
- bit 2 **T1SYNC:** Timer1 External Clock Input Synchronization Control bit
 TMR1CS = 1:
 1 = Do not synchronize external clock input
 0 = Synchronize external clock input
 TMR1CS = 0:
 This bit is ignored. Timer1 uses the internal clock.
- bit 1 **TMR1CS:** Timer1 Clock Source Select bit
 1 = External clock from T1OSO/T1CKI pin (on the rising edge)
 0 = Internal clock (Fosc/4)
- bit 0 **TMR1ON:** Timer1 On bit
 1 = Enables Timer1
 0 = Stops Timer1

Legend:			
R = Readable bit	W = Writable bit	U = Unimplemented bit, read as '0'	
- n = Value at POR	'1' = Bit is set	'0' = Bit is cleared	x = Bit is unknown

5.4 Timer1 Operation in Asynchronous Counter Mode

If control bit $\overline{T1SYNC}$ (T1CON<2>) is set, the external clock input is not synchronized. The timer continues to increment asynchronous to the internal phase clocks. The timer will continue to run during SLEEP and can generate an interrupt on overflow, which will wake-up the processor. However, special precautions in software are needed to read/write the timer (Section 5.4.1).

Note: The ANSEL (9Fh) and CMCON (19h) registers must be initialized to configure an analog channel as a digital input. Pins configured as analog inputs will read '0'.

5.4.1 READING AND WRITING TIMER1 IN ASYNCHRONOUS COUNTER MODE

Reading TMR1H or TMR1L, while the timer is running from an external asynchronous clock, will ensure a valid read (taken care of in hardware). However, the user should keep in mind that reading the 16-bit timer in two 8-bit values itself, poses certain problems, since the timer may overflow between the reads.

For writes, it is recommended that the user simply stop the timer and write the desired values. A write contention may occur by writing to the timer registers, while the register is incrementing. This may produce an unpredictable value in the timer register.

Reading the 16-bit value requires some care. Examples 12-2 and 12-3 in the *PIC Mid-Range MCU Family Reference Manual* (DS33023) show how to read and write Timer1 when it is running in Asynchronous mode.

5.5 Timer1 Oscillator

A crystal oscillator circuit is built-in between pins OSC1 (input) and OSC2 (amplifier output). It is enabled by setting control bit T1OSCEN (T1CON<3>). The oscillator is a low power oscillator rated up to 37 kHz. It will continue to run during SLEEP. It is primarily intended for a 32 kHz crystal. Table 10-2 shows the capacitor selection for the Timer1 oscillator.

The Timer1 oscillator is shared with the system LP oscillator. Thus, Timer1 can use this mode only when the system clock is derived from the internal oscillator. As with the system LP oscillator, the user must provide a software time delay to ensure proper oscillator start-up.

While enabled, TRISIO4 and TRISIO5 are set. GP4 and GP5 read '0' and TRISIO4 and TRISIO5 are read '1'.

Note: The oscillator requires a start-up and stabilization time before use. Thus, T1OSCEN should be set and a suitable delay observed prior to enabling Timer1.

5.6 Timer1 Operation During SLEEP

Timer1 can only operate during SLEEP when setup in Asynchronous Counter mode. In this mode, an external crystal or clock source can be used to increment the counter. To setup the timer to wake the device:

- Timer1 must be on (T1CON<0>)
- TMR1IE bit (PIE1<0>) must be set
- PEIE bit (INTCON<6>) must be set

The device will wake-up on an overflow. If the GIE bit (INTCON<7>) is set, the device will wake-up and jump to the Interrupt Service Routine on an overflow.

TABLE 5-1: REGISTERS ASSOCIATED WITH TIMER1 AS A TIMER/COUNTER

Address	Name	Bit 7	Bit 6	Bit 5	Bit 4	Bit 3	Bit 2	Bit 1	Bit 0	Value on POR, BOD	Value on all other RESETS
0Bh/8Bh	INTCON	GIE	PEIE	T0IE	INTE	GPIE	T0IF	INTF	GPIF	0000 0000	0000 000u
0Ch	PIR1	EEIF	ADIF	—	—	CMIF	—	—	TMR1IF	00-- 0--0	00-- 0--0
0Eh	TMR1L	Holding Register for the Least Significant Byte of the 16-bit TMR1 Register							xxxx xxxx	uuuu uuuu	
0Fh	TMR1H	Holding Register for the Most Significant Byte of the 16-bit TMR1 Register							xxxx xxxx	uuuu uuuu	
10h	T1CON	—	TMR1GE	T1CKPS1	T1CKPS0	T1OSCEN	$\overline{T1SYNC}$	TMR1CS	TMR1ON	-000 0000	-uuu uuuu
8Ch	PIE1	EEIE	ADIE	—	—	CMIE	—	—	TMR1IE	00-- 0--0	00-- 0--0

Legend: x = unknown, u = unchanged, - = unimplemented, read as '0'. Shaded cells are not used by the Timer1 module.

rfPIC12F675

NOTES:

6.0 COMPARATOR MODULE

The rfPIC12F675 devices have one analog comparator. The inputs to the comparator are multiplexed with the GP0 and GP1 pins. There is an on-chip Comparator Voltage Reference that can also

be applied to an input of the comparator. In addition, GP2 can be configured as the comparator output. The Comparator Control Register (CMCON), shown in Register 6-1, contains the bits to control the comparator.

REGISTER 6-1: CMCON — COMPARATOR CONTROL REGISTER (ADDRESS: 19h)

U-0	R-0	U-0	R/W-0	R/W-0	R/W-0	R/W-0	R/W-0	
—	COUT	—	CINV	CIS	CM2	CM1	CM0	
bit 7								bit 0

bit 7 **Unimplemented:** Read as '0'

bit 6 **COUT:** Comparator Output bit
When CINV = 0:
 1 = $V_{IN+} > V_{IN-}$
 0 = $V_{IN+} < V_{IN-}$
When CINV = 1:
 1 = $V_{IN+} < V_{IN-}$
 0 = $V_{IN+} > V_{IN-}$

bit 5 **Unimplemented:** Read as '0'

bit 4 **CINV:** Comparator Output Inversion bit
 1 = Output inverted
 0 = Output not inverted

bit 3 **CIS:** Comparator Input Switch bit
When CM2:CM0 = 110 or 101:
 1 = V_{IN-} connects to $CIN+$
 0 = V_{IN-} connects to $CIN-$

bit 2-0 **CM2:CM0:** Comparator Mode bits
 Figure 6-2 shows the Comparator modes and CM2:CM0 bit settings

Legend:			
R = Readable bit	W = Writable bit	U = Unimplemented bit, read as '0'	
- n = Value at POR	'1' = Bit is set	'0' = Bit is cleared	x = Bit is unknown

6.1 Comparator Operation

A single comparator is shown in Figure 6-1, along with the relationship between the analog input levels and the digital output. When the analog input at V_{IN+} is less than the analog input V_{IN-} , the output of the comparator is a digital low level. When the analog input at V_{IN+} is greater than the analog input V_{IN-} , the output of the comparator is a digital high level. The shaded areas of the output of the comparator in Figure 6-1 represent the uncertainty due to input offsets and response time.

Note: To use $CIN+$ and $CIN-$ pins as analog inputs, the appropriate bits must be programmed in the $CMCON$ (19h) register.

The polarity of the comparator output can be inverted by setting the $CINV$ bit ($CMCON<4>$). Clearing $CINV$ results in a non-inverted output. A complete table showing the output state versus input conditions and the polarity bit is shown in Table 6-1.

TABLE 6-1: OUTPUT STATE VS. INPUT CONDITIONS

Input Conditions	$CINV$	$COUT$
$V_{IN-} > V_{IN+}$	0	0
$V_{IN-} < V_{IN+}$	0	1
$V_{IN-} > V_{IN+}$	1	1
$V_{IN-} < V_{IN+}$	1	0

FIGURE 6-1: SINGLE COMPARATOR

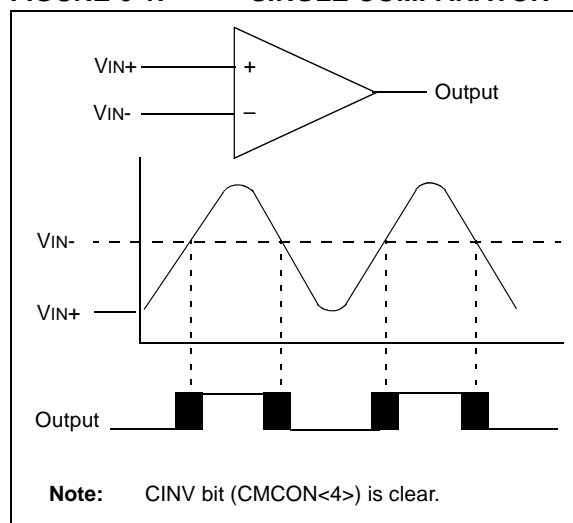

6.2 Comparator Configuration

There are eight modes of operation for the comparator. The CMCON register, shown in Register 6-1, is used to select the mode. Figure 6-2 shows the eight possible modes. The TRISIO register controls the data direction of the comparator pins for each mode. If the

Comparator mode is changed, the comparator output level may not be valid for a specified period of time. Refer to the specifications in Section 13.0.

Note: Comparator interrupts should be disabled during a Comparator mode change. Otherwise, a false interrupt may occur.

FIGURE 6-2: COMPARATOR I/O OPERATING MODES

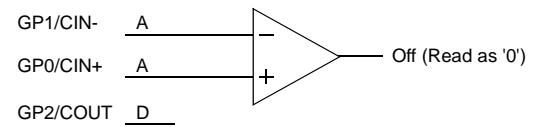
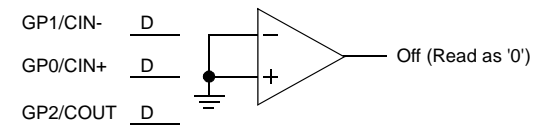
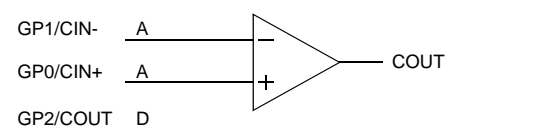
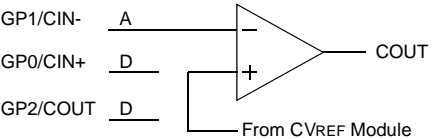
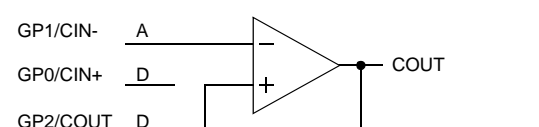
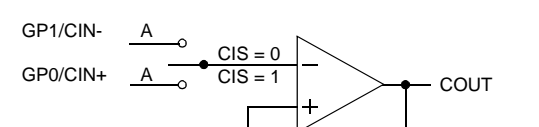
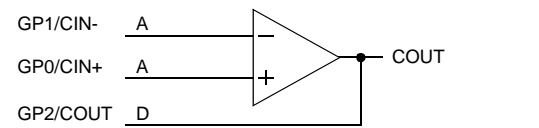
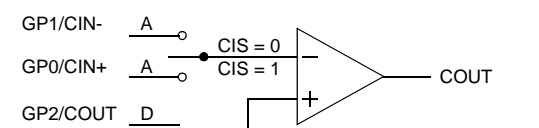
<p>Comparator Reset (POR Default Value - low power) CM2:CM0 = 000</p> 	<p>Comparator Off (Lowest power) CM2:CM0 = 111</p> 
<p>Comparator without Output CM2:CM0 = 010</p> 	<p>Comparator w/o Output and with Internal Reference CM2:CM0 = 100</p> 
<p>Comparator with Output and Internal Reference CM2:CM0 = 011</p> 	<p>Multiplexed Input with Internal Reference and Output CM2:CM0 = 101</p> 
<p>Comparator with Output CM2:CM0 = 001</p> 	<p>Multiplexed Input with Internal Reference CM2:CM0 = 110</p> 
<p>A = Analog Input, ports always reads '0' D = Digital Input CIS = Comparator Input Switch (CMCON<3>)</p>	

6.3 Analog Input Connection Considerations

A simplified circuit for an analog input is shown in Figure 6-3. Since the analog pins are connected to a digital output, they have reverse biased diodes to VDD and VSS. The analog input, therefore, must be between VSS and VDD. If the input voltage deviates from this

range by more than 0.6V in either direction, one of the diodes is forward biased and a latchup may occur. A maximum source impedance of 10 kΩ is recommended for the analog sources. Any external component connected to an analog input pin, such as a capacitor or a Zener diode, should have very little leakage current.

FIGURE 6-3: ANALOG INPUT MODE

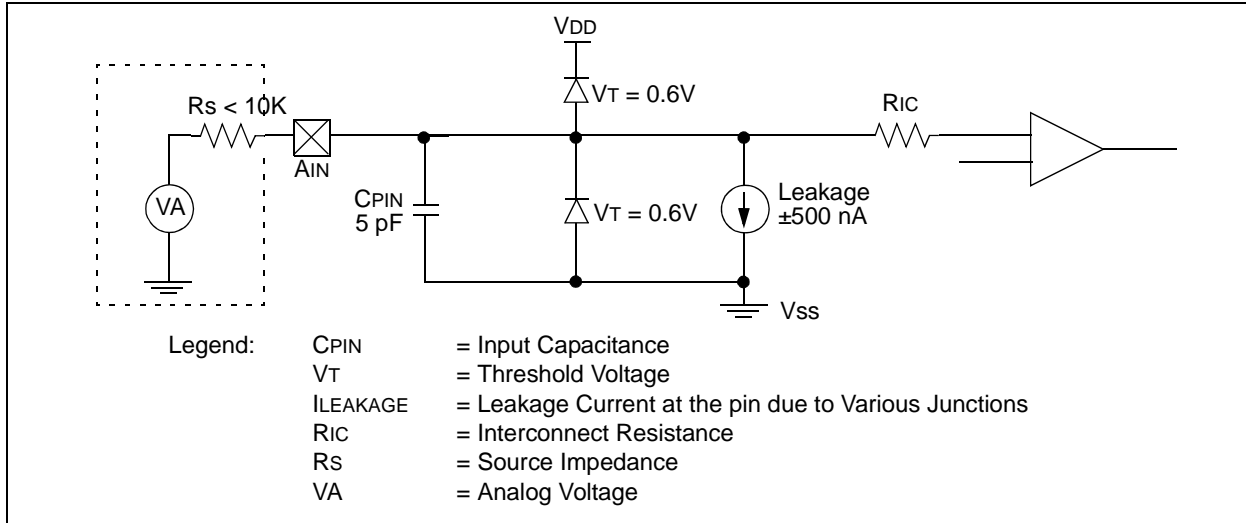

6.4 Comparator Output

The comparator output, COUT, is read through the CMCON register. This bit is read-only. The comparator output may also be directly output to the GP2 pin in three of the eight possible modes, as shown in Figure 6-2. When in one of these modes, the output on GP2 is asynchronous to the internal clock. Figure 6-4 shows the comparator output block diagram.

The TRISIO<2> bit functions as an output enable/disable for the GP2 pin while the comparator is in an Output mode.

Note 1: When reading the GPIO register, all pins configured as analog inputs will read as a '0'. Pins configured as digital inputs will convert an analog input according to the TTL input specification.

2: Analog levels on any pin that is defined as a digital input, may cause the input buffer to consume more current than is specified.

FIGURE 6-4: MODIFIED COMPARATOR OUTPUT BLOCK DIAGRAM

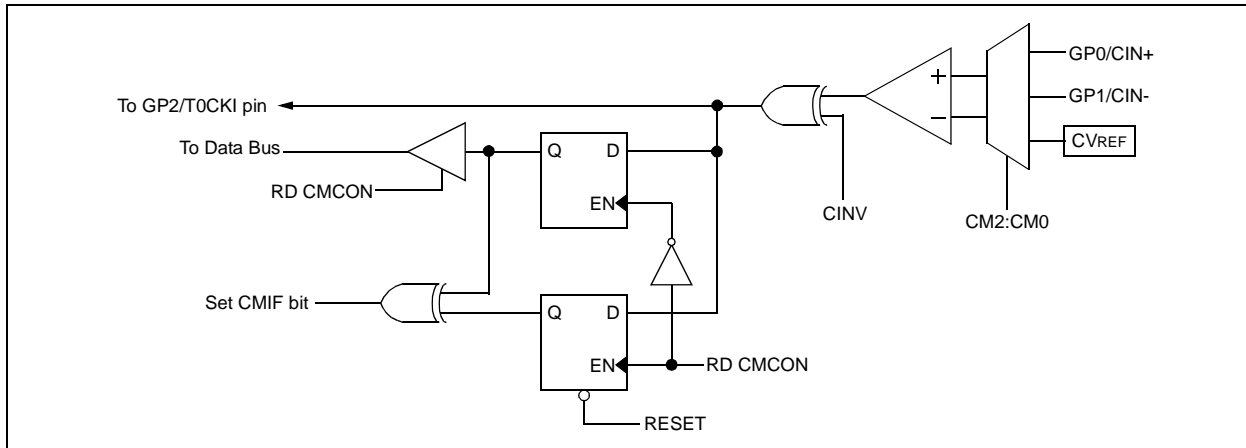

6.5 Comparator Reference

The comparator module also allows the selection of an internally generated voltage reference for one of the comparator inputs. The internal reference signal is used for four of the eight Comparator modes. The VRCON register, Register 6-2, controls the voltage reference module shown in Figure 6-5.

6.5.1 CONFIGURING THE VOLTAGE REFERENCE

The voltage reference can output 32 distinct voltage levels, 16 in a high range and 16 in a low range.

The following equations determine the output voltages:

$$VRR = 1 \text{ (low range): } CVREF = (VR3:VR0 / 24) \times VDD$$

$$VRR = 0 \text{ (high range): } CVREF = (VDD / 4) + (VR3:VR0 \times VDD / 32)$$

6.5.2 VOLTAGE REFERENCE ACCURACY/ERROR

The full range of VSS to VDD cannot be realized due to the construction of the module. The transistors on the top and bottom of the resistor ladder network (Figure 6-5) keep $CVREF$ from approaching VSS or VDD . The Voltage Reference is VDD derived and therefore, the $CVREF$ output changes with fluctuations in VDD . The tested absolute accuracy of the Comparator Voltage Reference can be found in Section 13.0.

FIGURE 6-5: COMPARATOR VOLTAGE REFERENCE BLOCK DIAGRAM

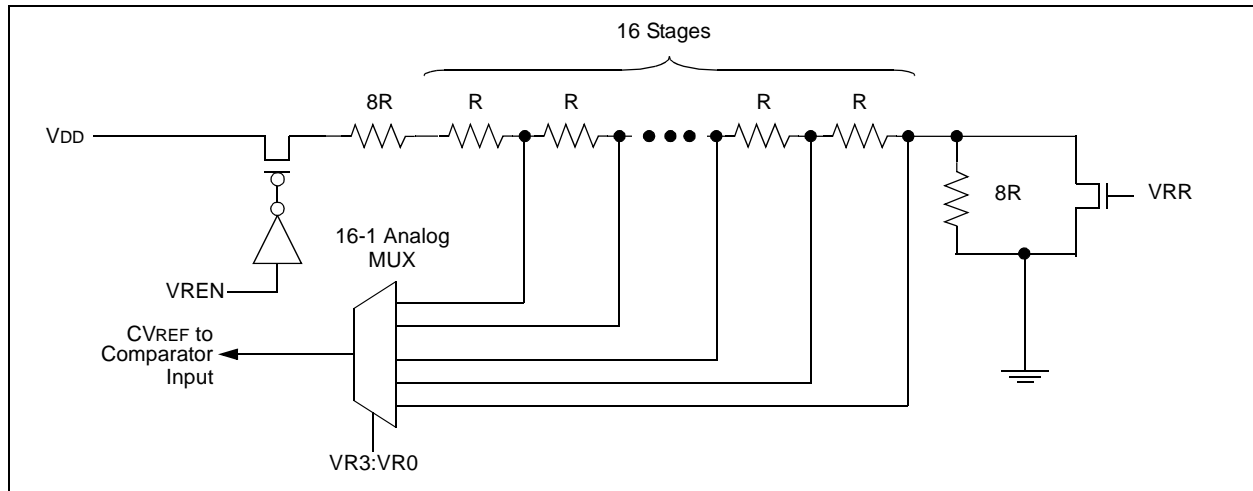

6.6 Comparator Response Time

Response time is the minimum time, after selecting a new reference voltage or input source, before the comparator output is ensured to have a valid level. If the internal reference is changed, the maximum delay of the internal voltage reference must be considered when using the comparator outputs. Otherwise, the maximum delay of the comparators should be used (Table 13-7).

6.7 Operation During SLEEP

Both the comparator and voltage reference, if enabled before entering SLEEP mode, remain active during SLEEP. This results in higher SLEEP currents than shown in the power-down specifications. The additional current consumed by the comparator and the voltage reference is shown separately in the specifications. To minimize power consumption while in SLEEP mode, turn off the comparator, $CM2:CM0 = 111$, and voltage reference, $VRCON<7> = 0$.

While the comparator is enabled during SLEEP, an interrupt will wake-up the device. If the device wakes up from SLEEP, the contents of the CMCON and VRCON registers are not affected.

6.8 Effects of a RESET

A device RESET forces the CMCON and VRCON registers to their RESET states. This forces the comparator module to be in the Comparator Reset mode, $CM2:CM0 = 000$ and the voltage reference to its off state. Thus, all potential inputs are analog inputs with the comparator and voltage reference disabled to consume the smallest current possible.

rfPIC12F675

REGISTER 6-2: VRCON — VOLTAGE REFERENCE CONTROL REGISTER (ADDRESS: 99h)

R/W-0	U-0	R/W-0	R/W-0	R/W-0	R/W-0	R/W-0	R/W-0
VREN	—	VRR	—	VR3	VR2	VR1	VR0
bit 7				bit 0			

- bit 7 **VREN:** CVREF Enable bit
1 = CVREF circuit powered on
0 = CVREF circuit powered down, no IDD drain
- bit 6 **Unimplemented:** Read as '0'
- bit 5 **VRR:** CVREF Range Selection bit
1 = Low range
0 = High range
- bit 4 **Unimplemented:** Read as '0'
- bit 3-0 **VR3:VR0:** CVREF value selection $0 \leq VR [3:0] \leq 15$
When VRR = 1: $CVREF = (VR3:VR0 / 24) * VDD$
When VRR = 0: $CVREF = VDD/4 + (VR3:VR0 / 32) * VDD$

Legend:

R = Readable bit W = Writable bit U = Unimplemented bit, read as '0'
 - n = Value at POR '1' = Bit is set '0' = Bit is cleared x = Bit is unknown

6.9 Comparator Interrupts

The comparator interrupt flag is set whenever there is a change in the output value of the comparator. Software will need to maintain information about the status of the output bits, as read from CMCON<6>, to determine the actual change that has occurred. The CMIF bit, PIR1<3>, is the comparator interrupt flag. This bit must be reset in software by clearing it to '0'. Since it is also possible to write a '1' to this register, a simulated interrupt may be initiated.

The CMIE bit (PIE1<3>) and the PEIE bit (INTCON<6>) must be set to enable the interrupt. In addition, the GIE bit must also be set. If any of these bits are cleared, the interrupt is not enabled, though the CMIF bit will still be set if an interrupt condition occurs.

The user, in the Interrupt Service Routine, can clear the interrupt in the following manner:

- a) Any read or write of CMCON. This will end the mismatch condition.
- b) Clear flag bit CMIF.

A mismatch condition will continue to set flag bit CMIF. Reading CMCON will end the mismatch condition, and allow flag bit CMIF to be cleared.

Note: If a change in the CMCON register (COUT) should occur when a read operation is being executed (start of the Q2 cycle), then the CMIF (PIR1<3>) interrupt flag may not get set.

TABLE 6-2: REGISTERS ASSOCIATED WITH COMPARATOR MODULE

Address	Name	Bit 7	Bit 6	Bit 5	Bit 4	Bit 3	Bit 2	Bit 1	Bit 0	Value on POR, BOD	Value on all other RESETS
0Bh/8Bh	INTCON	GIE	PEIE	T0IE	INTE	GPIE	T0IF	INTF	GPIF	0000 0000	0000 000u
0Ch	PIR1	EEIF	ADIF	—	—	CMIF	—	—	TMR1IF	00-- 0--0	00-- 0--0
19h	CMCON	—	COUT	—	CINV	CIS	CM2	CM1	CM0	-0-0 0000	-0-0 0000
8Ch	PIE1	EEIE	ADIE	—	—	CMIE	—	—	TMR1IE	00-- 0--0	00-- 0--0
85h	TRISIO	—	—	TRISIO5	TRISIO4	TRISIO3	TRISIO2	TRISIO1	TRISIO0	--11 1111	--11 1111
99h	VRCON	VREN	—	VRR	—	VR3	VR2	VR1	VR0	0-0- 0000	0-0- 0000

Legend: x = unknown, u = unchanged, - = unimplemented, read as '0'. Shaded cells are not used by the comparator module.

7.0 ANALOG-TO-DIGITAL CONVERTER (A/D) MODULE

The analog-to-digital converter (A/D) allows conversion of an analog input signal to a 10-bit binary representation of that signal. The rfPIC12F675 has four analog inputs, multiplexed into one sample and hold circuit.

The output of the sample and hold is connected to the input of the converter. The converter generates a binary result via successive approximation and stores the result in a 10-bit register. The voltage reference used in the conversion is software selectable to either VDD or a voltage applied by the VREF pin. Figure 7-1 shows the block diagram of the A/D.

FIGURE 7-1: A/D BLOCK DIAGRAM

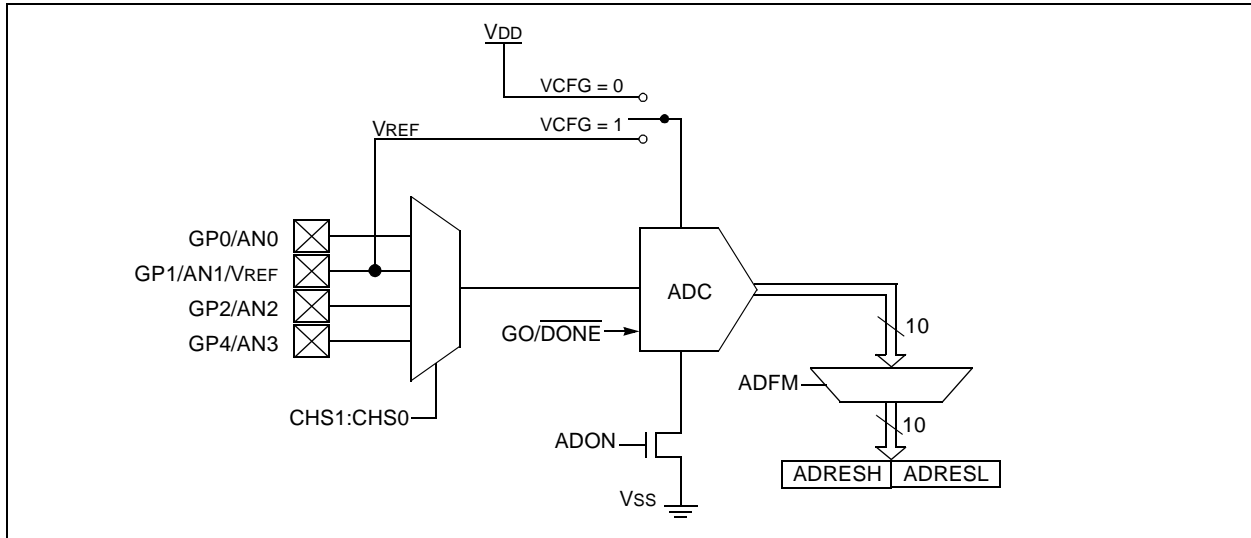

7.1 A/D Configuration and Operation

There are two registers available to control the functionality of the A/D module:

1. ADCON0 (Register 7-1)
2. ANSEL (Register 7-2)

7.1.1 ANALOG PORT PINS

The ANS3:ANS0 bits (ANSEL<3:0>) and the TRISIO bits control the operation of the A/D port pins. Set the corresponding TRISIO bits to set the pin output driver to its high impedance state. Likewise, set the corresponding ANS bit to disable the digital input buffer.

Note: Analog voltages on any pin that is defined as a digital input may cause the input buffer to conduct excess current.

7.1.2 CHANNEL SELECTION

There are four analog channels, AN0 through AN3. The CHS1:CHS0 bits (ADCON0<3:2>) control which channel is connected to the sample and hold circuit.

7.1.3 VOLTAGE REFERENCE

There are two options for the voltage reference to the A/D converter: either VDD is used, or an analog voltage applied to VREF is used. The VCFG bit (ADCON0<6>)

controls the voltage reference selection. If VCFG is set, then the voltage on the VREF pin is the reference; otherwise, VDD is the reference.

7.1.4 CONVERSION CLOCK

The A/D conversion cycle requires 11 TAD. The source of the conversion clock is software selectable via the ADCS bits (ANSEL<6:4>). There are seven possible clock options:

- FOSC/2
- FOSC/4
- FOSC/8
- FOSC/16
- FOSC/32
- FOSC/64
- FRC (dedicated internal RC oscillator)

For correct conversion, the A/D conversion clock (1/TAD) must be selected to ensure a minimum TAD of 1.6 μ s. Table 7-1 shows a few TAD calculations for selected frequencies.

TABLE 7-1: TAD vs. DEVICE OPERATING FREQUENCIES

A/D Clock Source (TAD)		Device Frequency			
Operation	ADCS2:ADCS0	20 MHz	5 MHz	4 MHz	1.25 MHz
2 TOSC	000	100 ns ⁽²⁾	400 ns ⁽²⁾	500 ns ⁽²⁾	1.6 μs
4 TOSC	100	200 ns ⁽²⁾	800 ns ⁽²⁾	1.0 μs ⁽²⁾	3.2 μs
8 TOSC	001	400 ns ⁽²⁾	1.6 μs	2.0 μs	6.4 μs
16 TOSC	101	800 ns ⁽²⁾	3.2 μs	4.0 μs	12.8 μs ⁽³⁾
32 TOSC	010	1.6 μs	6.4 μs	8.0 μs ⁽³⁾	25.6 μs ⁽³⁾
64 TOSC	110	3.2 μs	12.8 μs ⁽³⁾	16.0 μs ⁽³⁾	51.2 μs ⁽³⁾
A/D RC	x11	2 - 6 μs ^(1,4)	2 - 6 μs ^(1,4)	2 - 6 μs ^(1,4)	2 - 6 μs ^(1,4)

Legend: Shaded cells are outside of recommended range.

- Note 1:** The A/D RC source has a typical TAD time of 4 μs for VDD > 3.0V.
Note 2: These values violate the minimum required TAD time.
Note 3: For faster conversion times, the selection of another clock source is recommended.
Note 4: When the device frequency is greater than 1 MHz, the A/D RC clock source is only recommended if the conversion will be performed during SLEEP.

7.1.5 STARTING A CONVERSION

The A/D conversion is initiated by setting the GO/DONE bit (ADCON0<1>). When the conversion is complete, the A/D module:

- Clears the GO/DONE bit
- Sets the ADIF flag (PIR1<6>)
- Generates an interrupt (if enabled).

If the conversion must be aborted, the GO/DONE bit can be cleared in software. The ADRESH:ADRESL registers will not be updated with the partially complete A/D conversion sample. Instead, the ADRESH:ADRESL registers will retain the value of the

previous conversion. After an aborted conversion, a 2 TAD delay is required before another acquisition can be initiated. Following the delay, an input acquisition is automatically started on the selected channel.

Note: The GO/DONE bit should not be set in the same instruction that turns on the A/D.

7.1.6 CONVERSION OUTPUT

The A/D conversion can be supplied in two formats: left or right shifted. The ADFM bit (ADCON0<7>) controls the output format. Figure 7-2 shows the output formats.

FIGURE 7-2: 10-BIT A/D RESULT FORMAT

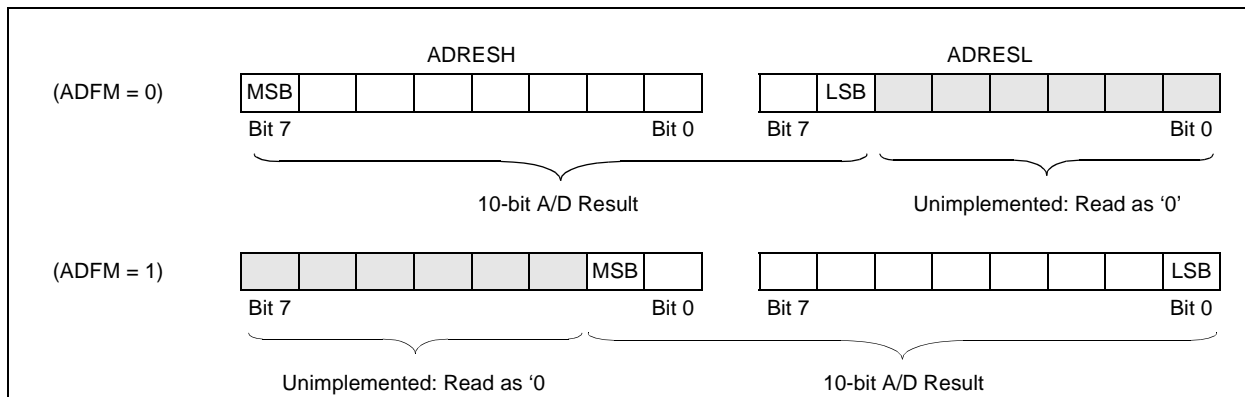

REGISTER 7-1: ADCON0 — A/D CONTROL REGISTER (ADDRESS: 1Fh)

R/W-0	R/W-0	U-0	U-0	R/W-0	R/W-0	R/W-0	R/W-0
ADFM	VCFG	—	—	CHS1	CHS0	GO/DONE	ADON
bit 7						bit 0	

- bit 7 **ADFM:** A/D Result Formed Select bit
 1 = Right justified
 0 = Left justified
- bit 6 **VCFG:** Voltage Reference bit
 1 = VREF pin
 0 = VDD
- bit 5-4 **Unimplemented:** Read as zero
- bit 3-2 **CHS1:CHS0:** Analog Channel Select bits
 00 = Channel 00 (AN0)
 01 = Channel 01 (AN1)
 10 = Channel 02 (AN2)
 11 = Channel 03 (AN3)
- bit 1 **GO/DONE:** A/D Conversion STATUS bit
 1 = A/D conversion cycle in progress. Setting this bit starts an A/D conversion cycle.
 This bit is automatically cleared by hardware when the A/D conversion has completed.
 0 = A/D conversion completed/not in progress
- bit 0 **ADON:** A/D Conversion STATUS bit
 1 = A/D converter module is operating
 0 = A/D converter is shut-off and consumes no operating current

Legend:			
R = Readable bit	W = Writable bit	U = Unimplemented bit, read as '0'	
- n = Value at POR	'1' = Bit is set	'0' = Bit is cleared	x = Bit is unknown

rfPIC12F675

REGISTER 7-2: ANSEL — ANALOG SELECT REGISTER (ADDRESS: 9Fh)

U-0	R/W-0	R/W-0	R/W-0	R/W-1	R/W-1	R/W-1	R/W-1
—	ADCS2	ADCS1	ADCS0	ANS3	ANS2	ANS1	ANS0

bit 7

bit 0

bit 7 **Unimplemented:** Read as '0'.

bit 6-4 **ADCS<2:0>:** A/D Conversion Clock Select bits

000 = Fosc/2

001 = Fosc/8

010 = Fosc/32

x11 = FRC (clock derived from a dedicated internal oscillator = 500 kHz max)

100 = Fosc/4

101 = Fosc/16

110 = Fosc/64

bit 3-0 **ANS3:ANS0:** Analog Select bits

(Between analog or digital function on pins AN<3:0>, respectively.)

1 = Analog input; pin is assigned as analog input⁽¹⁾

0 = Digital I/O; pin is assigned to port or special function

Note 1: Setting a pin to an analog input automatically disables the digital input circuitry, weak pull-ups, and interrupt-on-change. The corresponding TRISIO bit must be set to Input mode in order to allow external control of the voltage on the pin.

Legend:

R = Readable bit

W = Writable bit

U = Unimplemented bit, read as '0'

- n = Value at POR

'1' = Bit is set

'0' = Bit is cleared

x = Bit is unknown

7.2 A/D Acquisition Requirements

For the A/D converter to meet its specified accuracy, the charge holding capacitor (CHOLD) must be allowed to fully charge to the input channel voltage level. The analog input model is shown in Figure 7-3. The source impedance (RS) and the internal sampling switch (RSS) impedance directly affect the time required to charge the capacitor CHOLD. The sampling switch (RSS) impedance varies over the device voltage (VDD), see Figure 7-3. **The maximum recommended impedance for analog sources is 10 kΩ.** As the impedance

is decreased, the acquisition time may be decreased. After the analog input channel is selected (changed), this acquisition must be done before the conversion can be started.

To calculate the minimum acquisition time, Equation 7-1 may be used. This equation assumes that 1/2 LSB error is used (1024 steps for the A/D). The 1/2 LSB error is the maximum error allowed for the A/D to meet its specified resolution.

To calculate the minimum acquisition time, TACQ, see the *PIC Mid-Range Reference Manual (DS33023)*.

EQUATION 7-1: ACQUISITION TIME

$$\begin{aligned}
 T_{ACQ} &= \text{Amplifier Settling Time} + \\
 &\quad \text{Hold Capacitor Charging Time} + \\
 &\quad \text{Temperature Coefficient} \\
 &= T_{AMP} + T_C + T_{COFF} \\
 &= 2\mu\text{s} + T_C + [(\text{Temperature} - 25^\circ\text{C})(0.05\mu\text{s}/^\circ\text{C})] \\
 T_C &= \text{CHOLD} (\text{RIC} + \text{RSS} + R_S) \ln(1/2047) \\
 &= -120\text{pF} (1\text{k}\Omega + 7\text{k}\Omega + 10\text{k}\Omega) \ln(0.0004885) \\
 &= 16.47\mu\text{s} \\
 T_{ACQ} &= 2\mu\text{s} + 16.47\mu\text{s} + [(50^\circ\text{C} - 25^\circ\text{C})(0.05\mu\text{s}/^\circ\text{C})] \\
 &= 19.72\mu\text{s}
 \end{aligned}$$

Note 1: The reference voltage (VREF) has no effect on the equation, since it cancels itself out.

2: The charge holding capacitor (CHOLD) is not discharged after each conversion.

3: The maximum recommended impedance for analog sources is 10 kΩ. This is required to meet the pin leakage specification.

FIGURE 7-3: ANALOG INPUT MODEL

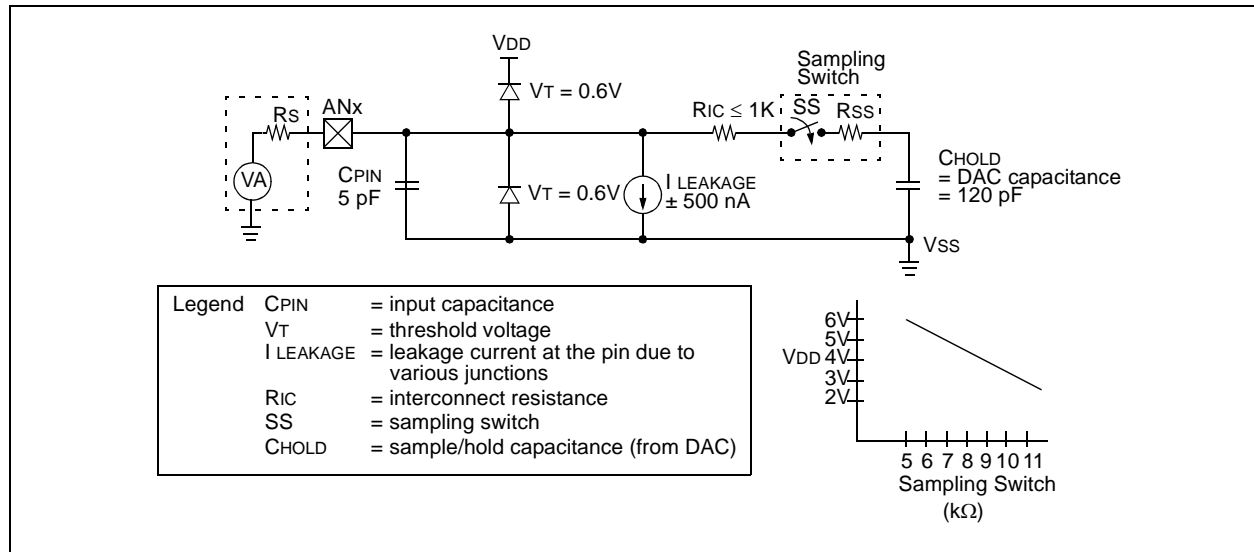

rfPIC12F675

7.3 A/D Operation During SLEEP

The A/D converter module can operate during SLEEP. This requires the A/D clock source to be set to the internal RC oscillator. When the RC clock source is selected, the A/D waits one instruction before starting the conversion. This allows the SLEEP instruction to be executed, thus eliminating much of the switching noise from the conversion. When the conversion is complete, the GO/DONE bit is cleared, and the result is loaded into the ADRESH:ADRESL registers. If the A/D interrupt is enabled, the device awakens from SLEEP. If the A/D interrupt is not enabled, the A/D module is turned off, although the ADON bit remains set.

When the A/D clock source is something other than RC, a SLEEP instruction causes the present conversion to be aborted, and the A/D module is turned off. The ADON bit remains set.

7.4 Effects of RESET

A device RESET forces all registers to their RESET state. Thus the A/D module is turned off and any pending conversion is aborted. The ADRESH:ADRESL registers are unchanged.

TABLE 7-2: SUMMARY OF A/D REGISTERS

Address	Name	Bit 7	Bit 6	Bit 5	Bit 4	Bit 3	Bit 2	Bit 1	Bit 0	Value on: POR, BOD	Value on all other RESETS
05h	GPIO	—	—	GPIO5	GPIO4	GPIO3	GPIO2	GPIO1	GPIO0	--xx xxxx	--uu uuuu
0Bh, 8Bh	INTCON	GIE	PEIE	T0IE	INTE	GPIE	T0IF	INTF	GPIF	0000 0000	0000 000u
0Ch	PIR1	EEIF	ADIF	—	—	CMIF	—	—	TMR1IF	00-- 0--0	00-- 0--0
1Eh	ADRESH	Most Significant 8 bits of the Left Shifted A/D result or 2 bits of the Right Shifted Result								xxxx xxxx	uuuu uuuu
1Fh	ADCON0	ADFM	VCFG	—	—	CHS1	CHS0	GO	ADON	00-- 0000	00-- 0000
85h	TRISIO	—	—	TRISIO5	TRISIO4	TRISIO3	TRISIO2	TRISIO1	TRISIO0	--11 1111	--11 1111
8Ch	PIE1	EEIE	ADIE	—	—	CMIE	—	—	TMR1IE	00-- 0--0	00-- 0--0
9Eh	ADRESL	Least Significant 2 bits of the Left Shifted A/D Result or 8 bits of the Right Shifted Result								xxxx xxxx	uuuu uuuu
9Fh	ANSEL	—	ADCS2	ADCS1	ADCS0	ANS3	ANS2	ANS1	ANS0	-000 1111	-000 1111

Legend: x = unknown, u = unchanged, - = unimplemented read as '0'. Shaded cells are not used for A/D converter module.

8.0 DATA EEPROM MEMORY

The EEPROM data memory is readable and writable during normal operation (full VDD range). This memory is not directly mapped in the register file space. Instead, it is indirectly addressed through the Special Function Registers. There are four SFRs used to read and write this memory:

- EECON1
- EECON2 (not a physically implemented register)
- EEDATA
- EEADR

EEDATA holds the 8-bit data for read/write, and EEADR holds the address of the EEPROM location being accessed. The rfPIC12F675 devices have 128 bytes of data EEPROM with an address range from 0h to 7Fh.

The EEPROM data memory allows byte read and write. A byte write automatically erases the location and writes the new data (erase before write). The EEPROM data memory is rated for high erase/write cycles. The write time is controlled by an on-chip timer. The write time will vary with voltage and temperature as well as from chip to chip. Please refer to AC Specifications for exact limits.

When the data memory is code protected, the CPU may continue to read and write the data EEPROM memory. The device programmer can no longer access this memory.

Additional information on the Data EEPROM is available in the *PIC Mid-Range Reference Manual* (DS33023).

REGISTER 8-1: EEDAT — EEPROM DATA REGISTER (ADDRESS: 9Ah)

R/W-0	R/W-0	R/W-0	R/W-0	R/W-0	R/W-0	R/W-0	R/W-0
EEDAT7	EEDAT6	EEDAT5	EEDAT4	EEDAT3	EEDAT2	EEDAT1	EEDAT0
bit 7							bit 0

bit 7-0 **EEDATn:** Byte value to write to or read from Data EEPROM

Legend:		
R = Readable bit	W = Writable bit	U = Unimplemented bit, read as '0'
- n = Value at POR	'1' = Bit is set	'0' = Bit is cleared x = Bit is unknown

REGISTER 8-2: EEADR — EEPROM ADDRESS REGISTER (ADDRESS: 9Bh)

U-0	R/W-0	R/W-0	R/W-0	R/W-0	R/W-0	R/W-0	R/W-0
—	EADR6	EADR5	EADR4	EADR3	EADR2	EADR1	EADR0
bit 7							bit 0

bit 7 **Unimplemented:** Should be set to '0'

bit 6-0 **EEADR:** Specifies one of 128 locations for EEPROM Read/Write Operation

Legend:		
R = Readable bit	W = Writable bit	U = Unimplemented bit, read as '0'
- n = Value at POR	'1' = Bit is set	'0' = Bit is cleared x = Bit is unknown

rfPIC12F675

8.1 EEADR

The EEADR register can address up to a maximum of 128 bytes of data EEPROM. Only seven of the eight bits in the register (EEADR<6:0>) are required. The MSb (bit 7) is ignored.

The upper bit should always be '0' to remain upward compatible with devices that have more data EEPROM memory.

8.2 EECON1 AND EECON2 REGISTERS

EECON1 is the control register with four low order bits physically implemented. The upper four bits are non-implemented and read as '0's.

Control bits RD and WR initiate read and write, respectively. These bits cannot be cleared, only set, in software. They are cleared in hardware at completion

of the read or write operation. The inability to clear the WR bit in software prevents the accidental, premature termination of a write operation.

The WREN bit, when set, will allow a write operation. On power-up, the WREN bit is clear. The WRERR bit is set when a write operation is interrupted by a MCLR Reset, or a WDT Time-out Reset during normal operation. In these situations, following RESET, the user can check the WRERR bit, clear it, and rewrite the location. The data and address will be cleared, therefore, the EEDATA and EEADR registers will need to be re-initialized.

Interrupt flag bit EEIF in the PIR1 register is set when write is complete. This bit must be cleared in software.

EECON2 is not a physical register. Reading EECON2 will read all '0's. The EECON2 register is used exclusively in the Data EEPROM write sequence.

REGISTER 8-3: EECON1 — EEPROM CONTROL REGISTER (ADDRESS: 9Ch)

U-0	U-0	U-0	U-0	R/W-x	R/W-0	R/S-0	R/S-0
—	—	—	—	WRERR	WREN	WR	RD
bit 7				bit 0			

- bit 7-4 **Unimplemented:** Read as '0'
- bit 3 **WRERR:** EEPROM Error Flag bit
1 = A write operation is prematurely terminated (any MCLR Reset, any WDT Reset during normal operation or BOD detect)
0 = The write operation completed
- bit 2 **WREN:** EEPROM Write Enable bit
1 = Allows write cycles
0 = Inhibits write to the data EEPROM
- bit 1 **WR:** Write Control bit
1 = Initiates a write cycle (The bit is cleared by hardware once write is complete. The WR bit can only be set, not cleared, in software.)
0 = Write cycle to the data EEPROM is complete
- bit 0 **RD:** Read Control bit
1 = Initiates an EEPROM read (Read takes one cycle. RD is cleared in hardware. The RD bit can only be set, not cleared, in software.)
0 = Does not initiate an EEPROM read

Legend:			
S = Bit can only be set			
R = Readable bit	W = Writable bit	U = Unimplemented bit, read as '0'	
- n = Value at POR	'1' = Bit is set	'0' = Bit is cleared	x = Bit is unknown

8.3 READING THE EEPROM DATA MEMORY

To read a data memory location, the user must write the address to the EEADR register and then set control bit RD (EECON1<0>), as shown in Example 8-1. The data is available, in the very next cycle, in the EEDATA register. Therefore, it can be read in the next instruction. EEDATA holds this value until another read, or until it is written to by the user (during a write operation).

EXAMPLE 8-1: DATA EEPROM READ

```

bsf    STATUS,RP0    ;Bank 1
movlw  CONFIG_ADDR  ;
movwf  EEADR         ;Address to read
bsf    EECON1,RD     ;EE Read
movf   EEDATA,W      ;Move data to W
    
```

8.4 WRITING TO THE EEPROM DATA MEMORY

To write an EEPROM data location, the user must first write the address to the EEADR register and the data to the EEDATA register. Then the user must follow a specific sequence to initiate the write for each byte, as shown in Example 8-2.

EXAMPLE 8-2: DATA EEPROM WRITE

```

bsf    STATUS,RP0    ;Bank 1
bsf    EECON1,WREN   ;Enable write
bcf    INTCON,GIE    ;Disable INTs
movlw  55h           ;Unlock write
movwf  EECON2        ;
movlw  AAh           ;
movwf  EECON2        ;
bsf    EECON1,WR     ;Start the write
bsf    INTCON,GIE    ;Enable INTS
    
```

The write will not initiate if the above sequence is not exactly followed (write 55h to EECON2, write AAh to EECON2, then set WR bit) for each byte. We strongly recommend that interrupts be disabled during this code segment. A cycle count is executed during the required sequence. Any number that is not equal to the required cycles to execute the required sequence will prevent the data from being written into the EEPROM.

Additionally, the WREN bit in EECON1 must be set to enable write. This mechanism prevents accidental writes to data EEPROM due to errant (unexpected) code execution (i.e., lost programs). The user should keep the WREN bit clear at all times, except when updating EEPROM. The WREN bit is not cleared by hardware.

After a write sequence has been initiated, clearing the WREN bit will not affect this write cycle. The WR bit will be inhibited from being set unless the WREN bit is set.

At the completion of the write cycle, the WR bit is cleared in hardware and the EE Write Complete Interrupt Flag bit (EEIF) is set. The user can either enable this interrupt or poll this bit. The EEIF bit (PIR<7>) register must be cleared by software.

8.5 WRITE VERIFY

Depending on the application, good programming practice may dictate that the value written to the data EEPROM should be verified (see Example 8-3) to the desired value to be written.

EXAMPLE 8-3: WRITE VERIFY

```

bcf    STATUS,RP0    ;Bank 0
:      ;Any code
bsf    STATUS,RP0    ;Bank 1 READ
movf   EEDATA,W      ;EEDATA not changed
:      ;from previous write
bsf    EECON1,RD     ;YES, Read the
:      ;value written
xorwf  EEDATA,W
btfsz  STATUS,Z      ;Is data the same
goto   WRITE_ERR     ;No, handle error
:      ;Yes, continue
    
```

8.5.1 USING THE DATA EEPROM

The data EEPROM is a high-endurance, byte addressable array that has been optimized for the storage of frequently changing information (e.g., program variables or other data that are updated often). Frequently changing values will typically be updated more often than specifications D120 or D120A. If this is not the case, an array refresh must be performed. For this reason, variables that change infrequently (such as constants, IDs, calibration, etc.) should be stored in FLASH program memory.

8.6 PROTECTION AGAINST SPURIOUS WRITE

There are conditions when the device may not want to write to the data EEPROM memory. To protect against spurious EEPROM writes, various mechanisms have been built in. On power-up, WREN is cleared. Also, the Power-up Timer (72 ms duration) prevents EEPROM write.

The write initiate sequence and the WREN bit together help prevent an accidental write during:

- brown-out
- power glitch
- software malfunction

rfPIC12F675

8.7 DATA EEPROM OPERATION DURING CODE PROTECT

Data memory can be code protected by programming the CPD bit to '0'.

When the data memory is code protected, the CPU is able to read and write data to the Data EEPROM. It is recommended to code protect the program memory when code protecting data memory. This prevents anyone from programming zeroes over the existing code (which will execute as NOPs) to reach an added routine, programmed in unused program memory, which outputs the contents of data memory. Programming unused locations to '0' will also help prevent data memory code protection from becoming breached.

TABLE 8-1: REGISTERS/BITS ASSOCIATED WITH DATA EEPROM

Address	Name	Bit 7	Bit 6	Bit 5	Bit 4	Bit 3	Bit 2	Bit 1	Bit 0	Value on POR, BOD	Value on all other RESETS	
0Ch	PIR1	EEIF	ADIF	—	—	CMIF	—	—	TMR1IF	00-- 0--0	00-- 0--0	
9Ah	EEDATA	EEPROM Data Register								0000 0000	0000 0000	
9Bh	EEADR	—	EEPROM Address Register								-000 0000	-000 0000
9Ch	EECON1	—	—	—	—	WRERR	WREN	WR	RD	---- x000	---- q000	
9Dh	EECON2 ⁽¹⁾	EEPROM Control Register 2								---- ----	---- ----	

Legend: x = unknown, u = unchanged, - = unimplemented read as '0', q = value depends upon condition.

Shaded cells are not used by Data EEPROM module.

Note 1: EECON2 is not a physical register.

9.0 UHF ASK/FSK TRANSMITTER

9.1 Transmitter Operation

The transmitter is a fully integrated UHF ASK/FSK transmitter consisting of crystal oscillator, Phase-Locked Loop (PLL), Power Amplifier (PA) with open-collector output, and mode control logic. There are 3 variations of this device to optimize its performance for the most commonly used frequency bands.

TABLE 9-1: FREQUENCY BANDS

Device	Frequency	Modulation
rfPIC12F675K	290-350 MHz	ASK/FSK
rfPIC12F675F	390-450 MHz	ASK/FSK
rfPIC12F675H	850-930 MHz	ASK/FSK

The internal structure of the transmitter is shown in Figure 9-1. A Colpitts oscillator generates the reference frequency set by the attached crystal. The voltage controlled oscillator (VCO) converts the voltage on the LF pin to a frequency. This frequency is divided by 32 and compared to the crystal reference. If the frequency or phase does not match the reference, the charge pump corrects the voltage on the LF pin. The VCO output signal is also amplified by the PA, whose single ended output drives the user's antenna.

The external components required are a crystal to set the transmit frequency, a supply bypass capacitor, and two to seven biasing/impedance matching components to get maximum power to the antenna. The two control signals from the microcontroller are connected externally for maximum design flexibility. The rfPIC12F675 is capable of transmitting data by Amplitude Shift Keying (ASK) or Frequency Shift Keying (FSK).

The rfPIC12F675 is a radio frequency (RF) emitting device. Wireless RF devices are governed by a country's regulating agency. For example, in the United States it is the Federal Communications Committee (FCC) and in Europe it is the European Conference of Postal and Telecommunications Administrations (CEPT). It is the responsibility of the designer to ensure that their end product conforms to rules and regulations of the country of use and/or sale.

RF devices require correct board level implementation in order to meet regulatory requirements. Layout considerations are listed at the end of each subsection. It is required to place a ground plane on the PCB to reduce unwanted radio frequency emissions.

FIGURE 9-1: TRANSMITTER BLOCK DIAGRAM

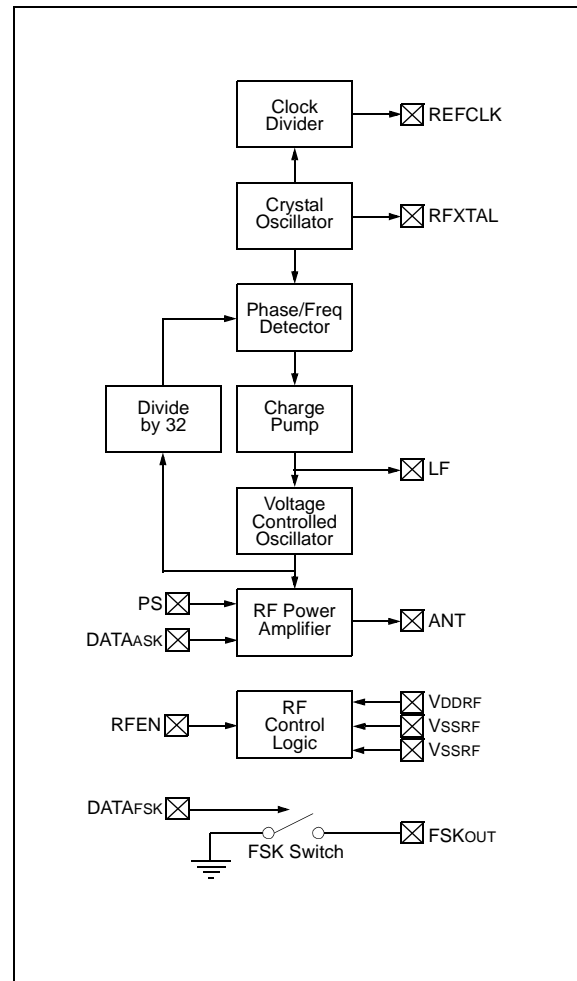

9.2 Supply Voltage (VDDRF, VSSRF)

Pins VDDRF and VSSRF supply power and ground respectively to the transmitter. These power pins are separate from power supply pins VDD and VSS to the microcontroller. Both VSSRF pins should be tied to the ground plane with the shortest possible traces. The microcontroller ground should be tied to the same RF ground potential. However, the VDDRF supply can be at a different potential than the microcontroller as long as the RFEN and DATA input levels are within specification limits.

Layout Considerations - Provide low impedance power and ground traces to minimize spurious emissions. A two-sided PCB with a ground plane on the bottom layer is highly recommended. Separate bypass capacitors should be connected as close as possible to each of the supply pins VDD and VDDRF. Connect both VSSRF pins to the ground plane using multiple PCB vias adjacent to the VSSRF pads. Do not share these PCB vias with other ground traces. Filter the VDDRF with an RC filter if the microcontroller noise spurs exceed regulatory limits.

rfPIC12F675

9.3 Crystal Oscillator

The transmitter crystal oscillator is a Colpitts oscillator that provides the reference frequency to the PLL. It is independent of the microcontroller oscillator. An external crystal or AC coupled reference signal is connected to the XTAL pin. The transmit frequency is fixed and determined by the crystal frequency according to the formula:

$$f_{transmit} = f_{RFX TAL} \times 32$$

Due to the flexible selection of transmit frequency, the resulting crystal frequency may not be a standard off-the-shelf value. Therefore, for some carrier frequencies the designer will have to consult a crystal manufacturer and have a custom crystal manufactured. For background information on crystal selection see Application Note AN588, *PIC® Microcontroller Oscillator Design Guide*, and AN826 *Crystal Oscillator Basics and Crystal Selection for rfPIC™ and PIC® Devices*.

For ASK modulation the crystal can be connected directly from RFX TAL to ground, or in series with an additional capacitor to trim the frequency. Figure 9-2 shows how the crystal is connected and Table 9-2 shows how the frequency of a typical crystal changes with capacitance.

The oscillator is enabled when the RFEN input is high. It takes the crystal approximately 1 ms to start oscillating. Higher frequency crystals start-up faster than lower frequencies. The crystal oscillator start time (TON) is listed in Table 13-11, Transmitter AC Characteristics. This start-up time is mainly due to the crystal building up an oscillation, but also includes the time for the PLL to lock on the crystal frequency.

9.4 ASK Modulation

In ASK modulation the data is transmitted by varying the output power. The DATAASK pin enables the PA, toggling the pin turns the RF output signal on and off. A simple receiver using a tuned filter and peak detector diode can capture the data. A more advanced super-heterodyne receiver such as the rfRXD0420 can greatly increase the range and reduce susceptibility to interference.

In ASK mode the DATAFSK and FSKOUT pins are not used and should both be tied to ground. An example of a typical ASK circuit is shown in Figure 9-5. The C1 capacitor can be replaced by a short to simplify the transmitter if the receiver has a wide enough bandwidth. For a very narrowband receiver the C1 capacitor may need to be replaced by a trimmer cap to tune the transmitter to the exact frequency.

FIGURE 9-2: ASK CRYSTAL CIRCUIT

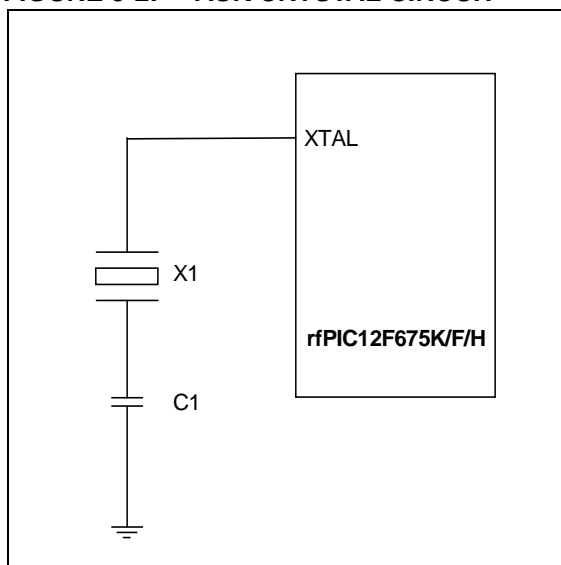

TABLE 9-2: XTAL OSC APPROXIMATE FREQ. VS. CAPACITANCE (ASK MODE) ⁽¹⁾

C1	Predicted Frequency (MHz)	PPM from 13.55 MHz	Transmit Frequency (MHz) (32 * fXTAL)
22 pF	13.551438	+106	433.646
39 pF	13.550563	+42	433.618
100 pF	13.549844	-12	433.595
150 pF	13.549672	-24	433.5895
470 pF	13.549548	-33	433.5856
1000 pF	13.549344	-48	433.579

Note 1: Standard Operating Conditions (unless otherwise stated) TA = 25°C, RFEN = 1, VDDRF = 3V, fXTAL = 13.55 MHz

9.5 FSK Modulation

In FSK modulation the transmit data is sent by varying the output frequency. This is done by loading the reference crystal with extra capacitance to pull it to a slightly lower frequency which the PLL then tracks. Switching the capacitance in and out with the data signal toggles the transmitter between two frequencies. These two crystal based frequencies are then multiplied by 32 for the RF transmit frequency.

Unlike the ASK transmit frequency the FSK center frequency is not actually transmitted. It is the artificial point half way between the two transmitted frequencies, calculated with this formula.

$$f_c = \frac{f_{\max} + f_{\min}}{2}$$

The other important parameter in FSK is the frequency deviation of the transmit frequency. This measures how far the frequency will swing from the center frequency. Single ended deviation is calculated with this formula.

$$\Delta f = \frac{f_{\max} - f_{\min}}{2}$$

An FSK receiver will specify its optimal value of deviation. The single ended deviation must be greater than data rate/4. The minimum deviation is usually limited by the frequency accuracy of the transmitter and receiver components. The maximum deviation is usually limited by the pulling characteristics of the transmitter crystal.

An extra capacitor and the internal switch are added to the ASK design to build an FSK transmitter as shown in Figure 9-3. The C1 capacitor in series with the crystal determines the maximum frequency.

With the DATAFSK pin high the FSKOUT pin is open and the C2 capacitor does not affect the frequency. When the DATAFSK pin goes low, FSKOUT shorts to ground, and the C2 is thrown in parallel with C1. The sum of the two caps pulls the oscillation frequency lower as shown in Figure 9-4.

In FSK mode the DATAASK pin should be tied high to enable the PA. The FSK circuit is shown in Figure 9-6. Use accurate crystals for narrow bandwidth systems and large values for C1 to reduce frequency drift.

FIGURE 9-3: FSK CRYSTAL CIRCUIT

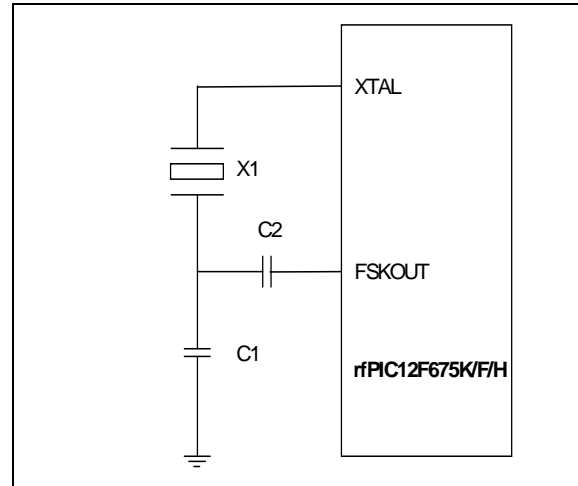

FIGURE 9-4: FREQUENCY PULLING

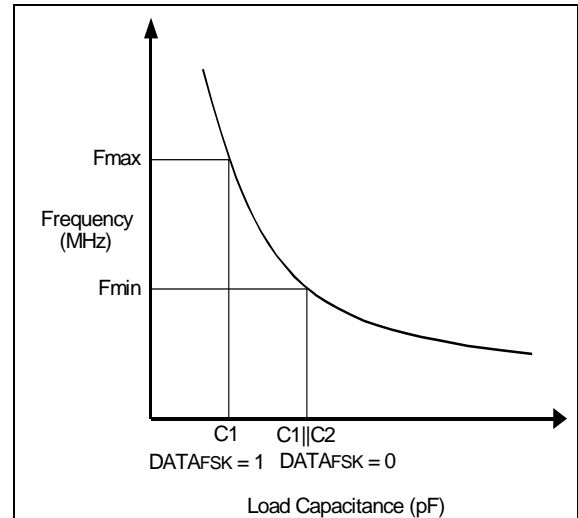

TABLE 9-3: TYPICAL TRANSMIT CENTER FREQUENCY AND DEVIATION (FSK MODE) ⁽¹⁾

C1 (pF)	C2 = 1000 pF	C2 = 100 pF	C2 = 47 pF
	Freq (MHz) / Dev (kHz)	Freq (MHz) / Dev (kHz)	Freq (MHz) / Dev (kHz)
22	433.612 / 34	433.619 / 27	433.625 / 21
33	433.604 / 25	433.610 / 19	433.614 / 14
39	433.598 / 20	433.604 / 14	433.608 / 10
47	433.596 / 17	433.601 / 11.5	433.604 / 8
68	433.593 / 13	433.598 / 9	433.600 / 5.5
100	433.587 / 8	—	—

Note 1: Standard Operating Conditions, TA = 25°C, RFEN = 1, VDDRF = 3V, fXTAL = 13.55 MHz

rfPIC12F675

FIGURE 9-5: TYPICAL ASK TRANSMITTER SCHEMATIC

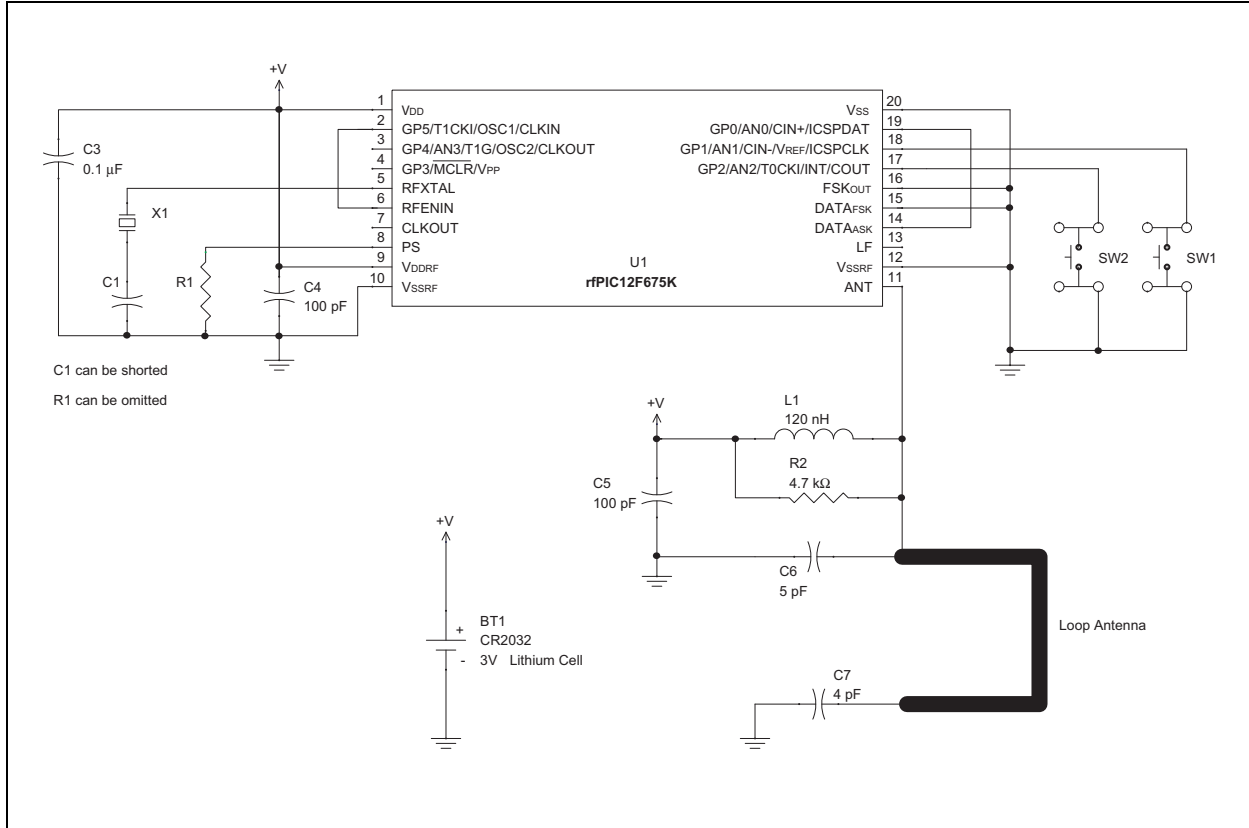
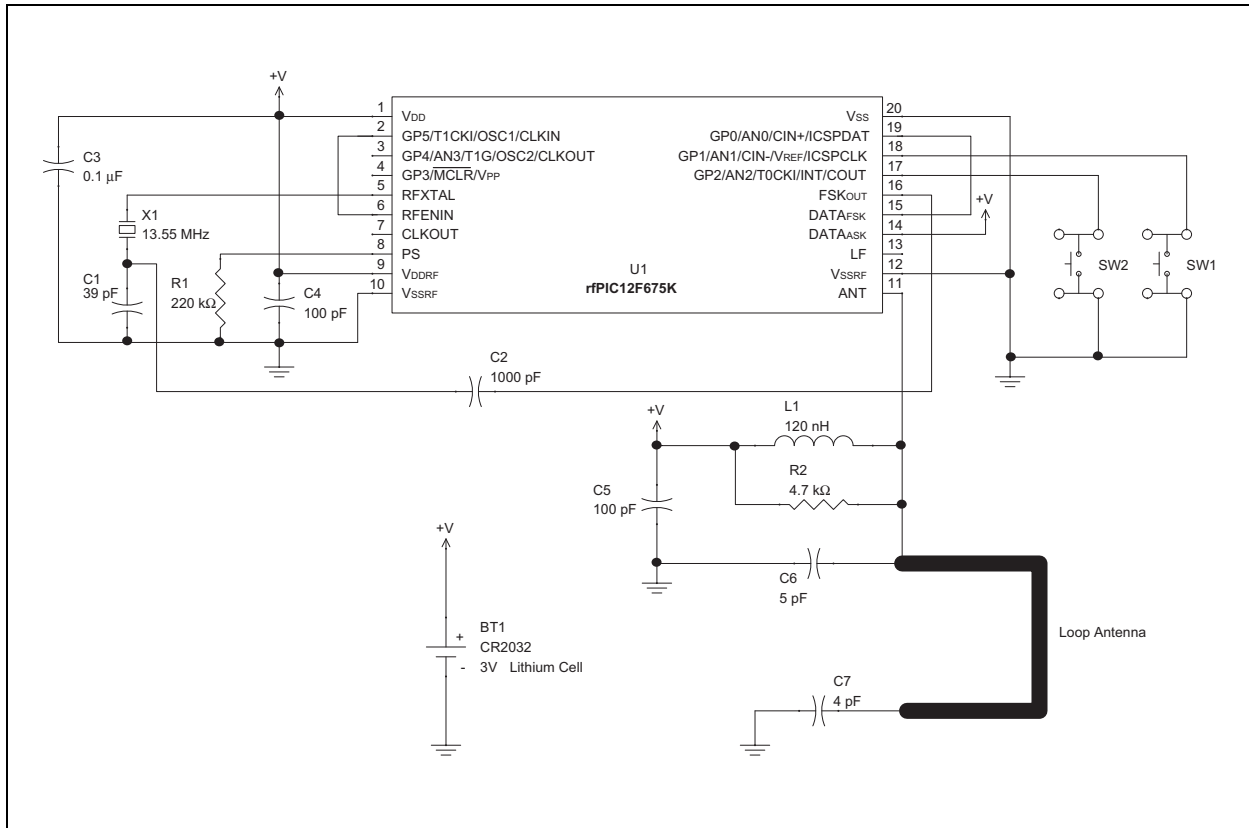

FIGURE 9-6: TYPICAL FSK TRANSMITTER SCHEMATIC



9.6 Clock Output

The clock output is available to the microcontroller or other circuits requiring an accurate reference frequency. This signal would typically be used to correct the internal RC oscillator for system designs that require accurate bit synchronization or tight time division multiplexing. The REFCLK output can connect directly to the TOCKI or T1CKI.

The REFCLK output frequency is the crystal oscillator divided by 4 on the rfPIC12F675K and rfPIC12F675F. For the rfPIC12F675H the crystal oscillator is divided by 8.

Layout considerations - Keep the clock trace short and narrow yet as far as possible from other traces to reduce capacitance and the associated current draw. If the REFCLK trace must pass near the crystal and LF nodes then shield them with ground traces.

9.7 Phase-Locked Loop Filter

The LF pin connects to an internal node on the PLL filter. Typically the pin should not be connected. In specialized cases it may be necessary to load this pin with extra capacitance to ground. Adding capacitance reduces the loop filter bandwidth which trades off an increase in phase noise for a reduction in clock spurs.

Useful diagnostic measurements can be taken on the LF pin with a high impedance, low capacitance probe. Measuring the time from RFEN going high until the LF voltage stabilizes will determine the minimum delay before the start of a transmission. For more information on PLL filters refer to Application Note AN846 *Basic PLL Filters for the rfPIC™/rfHCS*.

Layout considerations - Keep traces short and if the optional loop filter capacitor is required, place it as close as possible to the LF pin with its own via to the ground plane.

9.8 Power Amplifier

The PLL output feeds the power amplifier (PA) which drives the open-collector ANT output. The output should be DC biased with an inductor to the VDDRF supply. The output impedance must be matched to the load impedance to deliver the maximum power. This is typically done with a transformer or tapped capacitor circuit. Failure to match the impedance may cause excessive spurious and harmonic emissions. For more information on transformer matching see Application Note AN831, *Matching Small Loop Antennas to rfPIC™ Devices*. For more information on tapped capacitor matching see Application Note AN242 *Designing an FCC Approved ASK rfPIC™ Transmitter*.

The transmit output power can be adjusted in five discrete steps from +9 dBm to -70 dBm by varying the voltage on the PS pin. Since the PS pin has an internal 8 μA source the voltage can be set with a resistor from the PS pin to ground as shown in Figure 9-7. Some possible resistor values to set the current are shown in Table 9-4.

It is usually desirable to select the lowest power level step that does not compromise communications reliability. The most important benefit is the conservation of battery power. Another reason is to make it easier to pass regulatory limits. And a third reason is to reduce interference to other communications in the shared RF spectrum. Small inefficient antennas will require higher power level settings than larger efficient antennas.

FIGURE 9-7: .POWER SELECT CIRCUIT

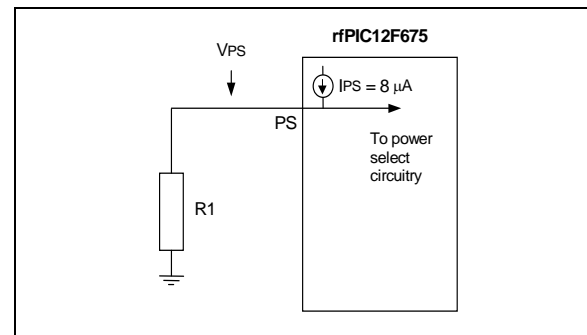

TABLE 9-4: POWER SELECT RESISTOR SELECTION (1,2)

Power Step	Output Power (dBm)	PS Voltage (Volts)	R1 Resistance (Ω)	RF Transmitter Current (mA)
4	9	1.6	open	10.7
3	2	0.8	100k ⁽³⁾	6.5
2	-4	0.4	47k ⁽³⁾	4.7
1	-12	0.2	22k ⁽³⁾	3.5
0	-70	0.1	short	2.7

Note 1: Standard Operating Conditions, TA = 25°C, RFEN = 1, VDDRF = 3V, fTRANSMIT = 433.92 MHz

2: Typical values, for complete specifications see data sheet Section 13.0.

3: R1 resistor variations plus IPS current supply variations must not exceed VPS step limits.

9.9 Digital Control Signals

The mode control logic pin RFEN controls the operation of the transmitter. When RFEN goes high, the crystal oscillator starts up. The voltage on the LF pin ramps up proportionally to the RF frequency. The PLL can lock onto the frequency faster than the starting up crystal can stabilize. When the LF pin reaches 0.8V, the RF frequency is close to locked on the crystal frequency. This initiates a 150 microsecond delay to ensure that the PLL settles. After the delay, the PS bias current and power amplifier are enabled to start transmitting when DATAASK goes high.

When RFEN is low, the transmitter goes into a very low power Standby mode. The power amplifier is disabled and the crystal oscillator stops. The RFEN pin has an internal pull-down resistor.

9.10 Low Voltage Output Disable

The rfPIC12F675 transmitter has a built in low voltage disable centered at about 1.85V. If the supply voltage drops below this voltage the power amplifier is disabled to prevent uncontrolled transmissions.

10.0 SPECIAL FEATURES OF THE CPU

Certain special circuits that deal with the needs of real time applications are what sets a microcontroller apart from other processors. The rfPIC12F675 Family has a host of such features intended to:

- maximize system reliability
- minimize cost through elimination of external components
- provide power saving operating modes and offer code protection.

These features are:

- Oscillator selection
- RESET
 - Power-on Reset (POR)
 - Power-up Timer (PWRT)
 - Oscillator Start-up Timer (OST)
 - Brown-out Detect (BOD)
- Interrupts
- Watchdog Timer (WDT)
- SLEEP
- Code protection
- ID Locations
- In-Circuit Serial Programming

The rfPIC12F675 has a Watchdog Timer that is controlled by configuration bits. It runs off its own RC oscillator for added reliability. There are two timers that offer necessary delays on power-up. One is the Oscillator Start-up Timer (OST), intended to keep the chip in RESET until the crystal oscillator is stable. The other is the Power-up Timer (PWRT), which provides a fixed delay of 72 ms (nominal) on power-up only, designed to keep the part in RESET while the power supply stabilizes. There is also circuitry to reset the device if a brown-out occurs, which can provide at least a 72 ms RESET. With these three functions on-chip, most applications need no external RESET circuitry.

The SLEEP mode is designed to offer a very low current Power-down mode. The user can wake-up from SLEEP through:

- External RESET
- Watchdog Timer wake-up
- An interrupt

Several oscillator options are also made available to allow the part to fit the application. The INTOSC option saves system cost while the LP crystal option saves power. A set of configuration bits are used to select various options (see Register 10-1).

rfPIC12F675

10.1 Configuration Bits

The configuration bits can be programmed (read as '0'), or left unprogrammed (read as '1') to select various device configurations, as shown in Register 10-1. These bits are mapped in program memory location 2007h.

Note: Address 2007h is beyond the user program memory space. It belongs to the special configuration memory space (2000h - 3FFFh), which can be accessed only during programming. See rfPIC12F675 Programming Specification for more information.

REGISTER 10-1: CONFIG — CONFIGURATION WORD (ADDRESS: 2007h)

R/P-1	R/P-1	U-0	U-0	U-0	R/P-1	R/P-1	R/P-1	R/P-1	R/P-1	R/P-1	R/P-1	R/P-1	R/P-1	R/P-1
BG1	BG0	—	—	—	$\overline{\text{CPD}}$	$\overline{\text{CP}}$	BODEN	MCLRE	$\overline{\text{PWRTÉ}}$	WDTE	FOSC2	FOSC1	FOSC0	
bit 13													bit 0	

bit 13-12 **BG1:BG0:** Bandgap Calibration bits for BOD and POR voltage⁽¹⁾
 00 = Lowest bandgap voltage
 11 = Highest bandgap voltage

bit 11-9 **Unimplemented:** Read as '0'

bit 8 **CPD:** Data Code Protection bit⁽²⁾
 1 = Data memory code protection is disabled
 0 = Data memory code protection is enabled

bit 7 **CP:** Code Protection bit⁽³⁾
 1 = Program Memory code protection is disabled
 0 = Program Memory code protection is enabled

bit 6 **BODEN:** Brown-out Detect Enable bit⁽⁴⁾
 1 = BOD enabled
 0 = BOD disabled

bit 5 **MCLRE:** GP3/MCLR pin function select⁽⁵⁾
 1 = GP3/MCLR pin function is MCLR
 0 = GP3/MCLR pin function is digital I/O, MCLR internally tied to VDD

bit 4 **PWRTÉ:** Power-up Timer Enable bit
 1 = PWRT disabled
 0 = PWRT enabled

bit 3 **WDTE:** Watchdog Timer Enable bit
 1 = WDT enabled
 0 = WDT disabled

bit 2-0 **FOSC2:FOSC0:** Oscillator Selection bits
 111 = RC oscillator: CLKOUT function on GP4/OSC2/CLKOUT pin, RC on GP5/OSC1/CLKIN
 110 = RC oscillator: I/O function on GP4/OSC2/CLKOUT pin, RC on GP5/OSC1/CLKIN
 101 = INTOSC oscillator: CLKOUT function on GP4/OSC2/CLKOUT pin, I/O function on GP5/OSC1/CLKIN
 100 = INTOSC oscillator: I/O function on GP4/OSC2/CLKOUT pin, I/O function on GP5/OSC1/CLKIN
 011 = EC: I/O function on GP4/OSC2/CLKOUT pin, CLKIN on GP5/OSC1/CLKIN
 010 = HS oscillator: High speed crystal/resonator on GP4/OSC2/CLKOUT and GP5/OSC1/CLKIN
 001 = XT oscillator: Crystal/resonator on GP4/OSC2/CLKOUT and GP5/OSC1/CLKIN
 000 = LP oscillator: Low power crystal on GP4/OSC2/CLKOUT and GP5/OSC1/CLKIN

- Note 1:** The Bandgap Calibration bits are factory programmed and must be read and saved prior to erasing the device as specified in the rfPIC12F675 Programming Specification. These bits are reflected in an export of the configuration word. Microchip Development Tools maintain all calibration bits to factory settings.
- 2:** The entire data EEPROM will be erased when the code protection is turned off.
- 3:** The entire program memory will be erased, including OSCCAL value, when the code protection is turned off.
- 4:** Enabling Brown-out Detect does not automatically enable Power-up Timer.
- 5:** When MCLR is asserted in INTOSC or RC mode, the internal clock oscillator is disabled.

Legend:

P = Programmed using ICSP	W = Writable bit	U = Unimplemented bit, read as '0'
R = Readable bit	1 = bit is set	0 = bit is cleared
-n = Value at POR		x = bit is unknown

10.2 Oscillator Configurations

10.2.1 OSCILLATOR TYPES

The rfPIC12F675 can be operated in eight different Oscillator Option modes. The user can program three configuration bits (FOSC2 through FOSC0) to select one of these eight modes:

- LP Low Power Crystal
- XT Crystal/Resonator
- HS High Speed Crystal/Resonator
- RC External Resistor/Capacitor (2 modes)
- INTOSC Internal Oscillator (2 modes)
- EC External Clock In

Note: Additional information on oscillator configurations is available in the *PICmicro™ Mid-Range Reference Manual*, (DS33023)

10.2.2 CRYSTAL OSCILLATOR / CERAMIC RESONATORS

In XT, LP or HS modes a crystal or ceramic resonator is connected to the OSC1 and OSC2 pins to establish oscillation (see Figure 10-1). The rfPIC12F675 oscillator design requires the use of a parallel cut crystal. Use of a series cut crystal may yield a frequency outside of the crystal manufacturers specifications. When in XT, LP or HS modes, the device can have an external clock source to drive the OSC1 pin (see Figure 10-2).

FIGURE 10-1: CRYSTAL OPERATION (OR CERAMIC RESONATOR) HS, XT OR LP OSC CONFIGURATION

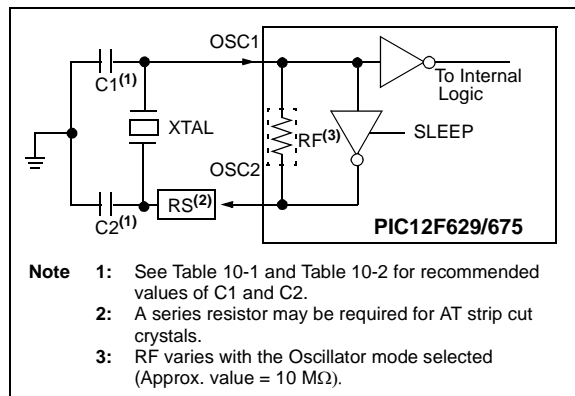

FIGURE 10-2: EXTERNAL CLOCK INPUT OPERATION (HS, XT, EC, OR LP OSC CONFIGURATION)

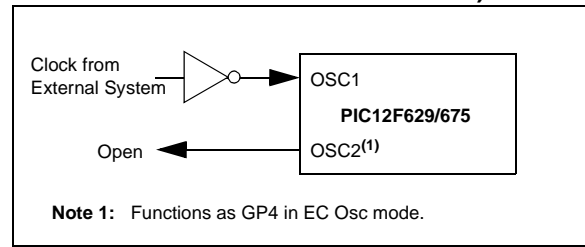

TABLE 10-1: CAPACITOR SELECTION FOR CERAMIC RESONATORS

Ranges Characterized:			
Mode	Freq	OSC1(C1)	OSC2(C2)
XT	455 kHz	68 - 100 pF	68 - 100 pF
	2.0 MHz	15 - 68 pF	15 - 68 pF
	4.0 MHz	15 - 68 pF	15 - 68 pF
HS	8.0 MHz	10 - 68 pF	10 - 68 pF
	16.0 MHz	10 - 22 pF	10 - 22 pF

Note 1: Higher capacitance increases the stability of the oscillator but also increases the start-up time. These values are for design guidance only. Since each resonator has its own characteristics, the user should consult the resonator manufacturer for appropriate values of external components.

TABLE 10-2: CAPACITOR SELECTION FOR CRYSTAL OSCILLATOR

Mode	Freq	OSC1(C1)	OSC2(C2)
LP	32 kHz	68 - 100 pF	68 - 100 pF
XT	100 kHz	68 - 150 pF	150 - 200 pF
	2 MHz	15 - 30 pF	15 - 30 pF
	4 MHz	15 - 30 pF	15 - 30 pF
HS	8 MHz	15 - 30 pF	15 - 30 pF
	10 MHz	15 - 30 pF	15 - 30 pF
	20 MHz	15 - 30 pF	15 - 30 pF

Note 1: Higher capacitance increases the stability of the oscillator but also increases the start-up time. These values are for design guidance only. Rs may be required in HS mode as well as XT mode to avoid overdriving crystals with low drive level specification. Since each crystal has its own characteristics, the user should consult the crystal manufacturer for appropriate values of external components.

rfPIC12F675

10.2.3 EXTERNAL CLOCK IN

For applications where a clock is already available elsewhere, users may directly drive the rfPIC12F675 provided that this external clock source meets the AC/DC timing requirements listed in Section 13.0. Figure 10-2 shows how an external clock circuit should be configured.

Note: The microcontroller oscillator is independent of the RF peripheral oscillator. An accurate time-base is still possible with only one crystal. Use the RF crystal on transmitter and tie the REFCLK signal back into T0CKI or T1CKI to correct the RC, INTOSC, or EC clocks. Since REFCLK is only active when RFEN=1, it is not a suitable source for CLKIN.

10.2.4 RC OSCILLATOR

For applications where precise timing is not a requirement, the RC oscillator option is available. The operation and functionality of the RC oscillator is dependent upon a number of variables. The RC oscillator frequency is a function of:

- Supply voltage
- Resistor (R_{EXT}) and capacitor (C_{EXT}) values
- Operating temperature

The oscillator frequency will vary from unit to unit due to normal process parameter variation. The difference in lead frame capacitance between package types will also affect the oscillation frequency, especially for low C_{EXT} values. The user also needs to account for the tolerance of the external R and C components. Figure 10-3 shows how the R/C combination is connected.

Two options are available for this Oscillator mode which allow GP4 to be used as a general purpose I/O or to output Fosc/4.

FIGURE 10-3: RC OSCILLATOR MODE

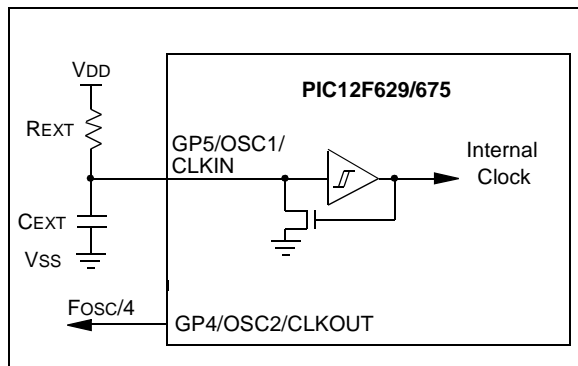

10.2.5 INTERNAL 4 MHz OSCILLATOR

When calibrated, the internal oscillator provides a fixed 4 MHz (nominal) system clock. See Electrical Specifications, Section 13.0, for information on variation over voltage and temperature.

Two options are available for this Oscillator mode which allow GP4 to be used as a general purpose I/O or to output Fosc/4.

10.2.5.1 Calibrating the Internal Oscillator

A calibration instruction is programmed into the last location of program memory. This instruction is a RETLW XX, where the literal is the calibration value. The literal is placed in the OSCCAL register to set the calibration of the internal oscillator. Example 10-1 demonstrates how to calibrate the internal oscillator. For best operation, decouple (with capacitance) VDD and VSS as close to the device as possible.

Note: Erasing the device will also erase the pre-programmed internal calibration value for the internal oscillator. The calibration value must be saved prior to erasing part as specified in the rfPIC12F675 Programming specification. Microchip Development Tools maintain all calibration bits to factory settings.

EXAMPLE 10-1: CALIBRATING THE INTERNAL OSCILLATOR

```
bsf    STATUS, RP0    ;Bank 1
call   3FFh           ;Get the cal value
movwf  OSCCAL         ;Calibrate
bcf    STATUS, RP0    ;Bank 0
```

10.2.6 CLKOUT

The rfPIC12F675 devices can be configured to provide a clock out signal in the INTOSC and RC oscillator modes. When configured, the oscillator frequency divided by four (Fosc/4) is output on the GP4/OSC2/CLKOUT pin. Fosc/4 can be used for test purposes or to synchronize other logic.

10.3 RESET

The rfPIC12F675 differentiates between various kinds of RESET:

- Power-on Reset (POR)
- WDT Reset during normal operation
- WDT Reset during SLEEP
- $\overline{\text{MCLR}}$ Reset during normal operation
- $\overline{\text{MCLR}}$ Reset during SLEEP
- Brown-out Detect (BOD)

Some registers are not affected in any RESET condition; their status is unknown on POR and unchanged in any other RESET. Most other registers are reset to a "RESET state" on:

- Power-on Reset
- $\overline{\text{MCLR}}$ Reset
- WDT Reset
- WDT Reset during SLEEP
- Brown-out Detect (BOD) Reset

They are not affected by a WDT wake-up, since this is viewed as the resumption of normal operation. $\overline{\text{TO}}$ and $\overline{\text{PD}}$ bits are set or cleared differently in different RESET situations as indicated in Table 10-4. These bits are used in software to determine the nature of the RESET. See Table 10-7 for a full description of RESET states of all registers.

A simplified block diagram of the On-Chip Reset Circuit is shown in Figure 10-4.

The $\overline{\text{MCLR}}$ Reset path has a noise filter to detect and ignore small pulses. See Table 13-4 in Electrical Specifications Section for pulse width specification.

FIGURE 10-4: SIMPLIFIED BLOCK DIAGRAM OF ON-CHIP RESET CIRCUIT

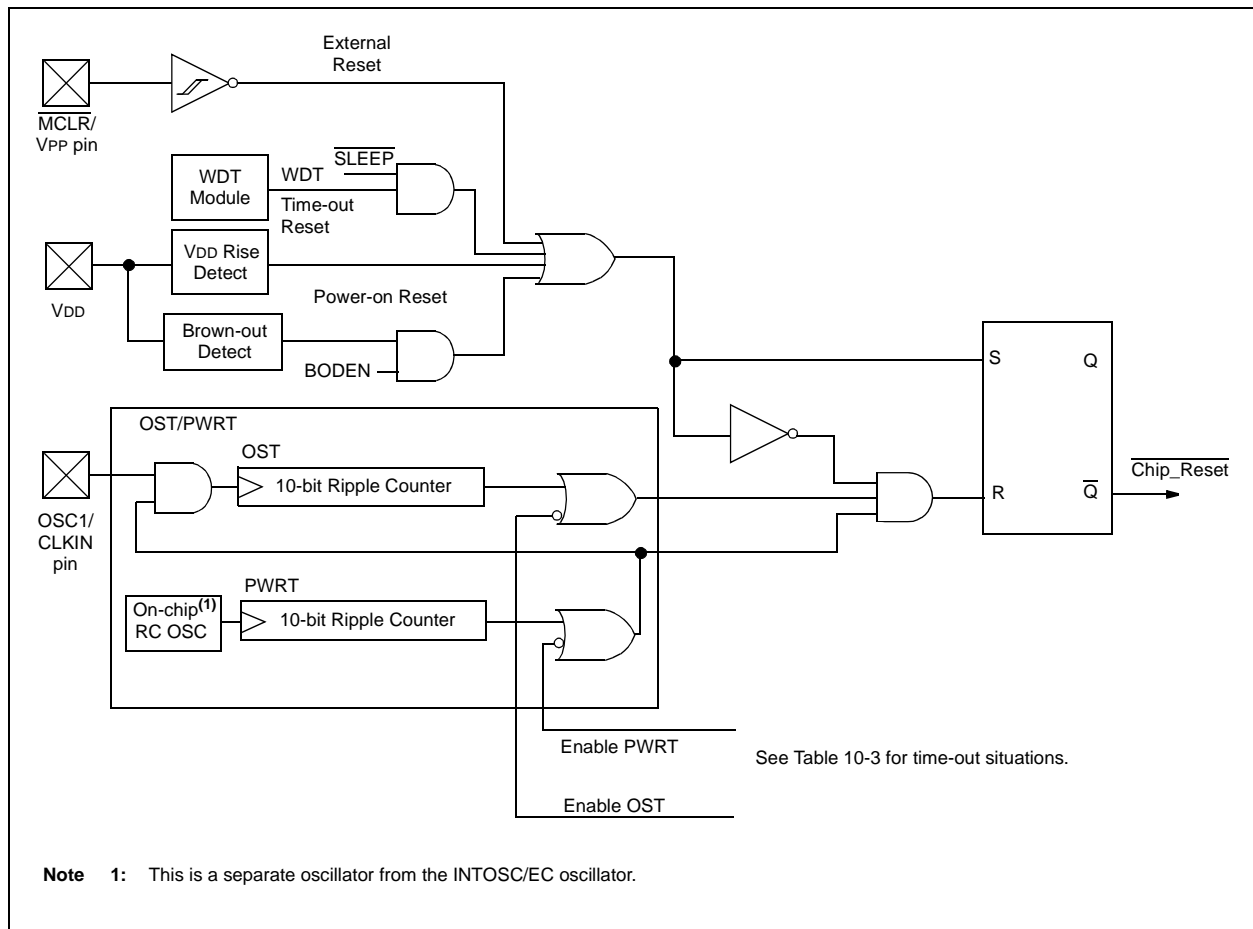

rfPIC12F675

10.3.1 $\overline{\text{MCLR}}$

The rfPIC12F675 devices have a noise filter in the $\overline{\text{MCLR}}$ Reset path. The filter will detect and ignore small pulses.

It should be noted that a WDT Reset does not drive $\overline{\text{MCLR}}$ pin low.

The behavior of the ESD protection on the $\overline{\text{MCLR}}$ pin has been altered from previous devices of this family. Voltages applied to the pin that exceed its specification can result in both $\overline{\text{MCLR}}$ Resets and excessive current beyond the device specification during the ESD event. For this reason, Microchip recommends that the $\overline{\text{MCLR}}$ pin no longer be tied directly to VDD. The use of an RC network, as shown in Figure 10-5, is suggested.

An internal $\overline{\text{MCLR}}$ option is enabled by setting the MCLRE bit in the configuration word. When enabled, $\overline{\text{MCLR}}$ is internally tied to VDD. No internal pull-up option is available for the $\overline{\text{MCLR}}$ pin.

FIGURE 10-5: RECOMMENDED $\overline{\text{MCLR}}$ CIRCUIT

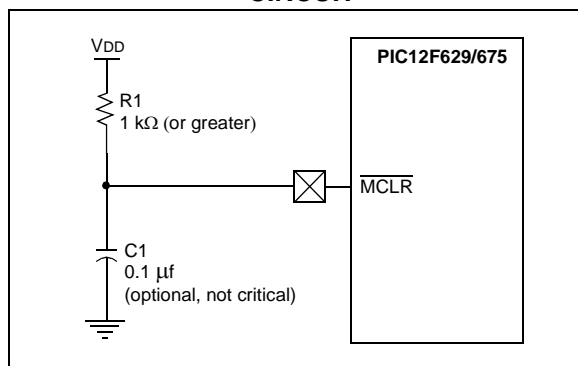

10.3.2 POWER-ON RESET (POR)

The on-chip POR circuit holds the chip in RESET until VDD has reached a high enough level for proper operation. To take advantage of the POR, simply tie the $\overline{\text{MCLR}}$ pin through a resistor to VDD. This will eliminate external RC components usually needed to create Power-on Reset. A maximum rise time for VDD is required. See Electrical Specifications for details (see Section 13.0).

Note: The POR circuit does not produce an internal RESET when VDD declines.

When the device starts normal operation (exits the RESET condition), device operating parameters (i.e., voltage, frequency, temperature, etc.) must be met to ensure operation. If these conditions are not met, the device must be held in RESET until the operating conditions are met.

For additional information, refer to Application Note AN607 "Power-up Trouble Shooting".

10.3.3 POWER-UP TIMER (PWRT)

The Power-up Timer provides a fixed 72 ms (nominal) time-out on power-up only, from POR or Brown-out Detect. The Power-up Timer operates on an internal RC oscillator. The chip is kept in RESET as long as PWRT is active. The PWRT delay allows the VDD to rise to an acceptable level. A configuration bit, PWRTE can disable (if set) or enable (if cleared or programmed) the Power-up Timer. The Power-up Timer should always be enabled when Brown-out Detect is enabled.

The Power-up Time delay will vary from chip to chip and due to:

- VDD variation
- Temperature variation
- Process variation

See DC parameters for details (Section 13.0).

10.3.4 OSCILLATOR START-UP TIMER (OST)

The Oscillator Start-up Timer (OST) provides a 1024 oscillator cycle (from OSC1 input) delay after the PWRT delay is over. This ensures that the crystal oscillator or resonator has started and stabilized.

The OST time-out is invoked only for XT, LP and HS modes and only on Power-on Reset or wake-up from SLEEP.

10.3.5 BROWN-OUT DETECT (BOD)

The rfPIC12F675 members have on-chip Brown-out Detect circuitry. A configuration bit, BODEN, can disable (if clear/programmed) or enable (if set) the Brown-out Detect circuitry. If VDD falls below VBOD for greater than parameter (TBOD) in Table 13-4 (see Section 13.0), the Brown-out situation will reset the device. This will occur regardless of VDD slew-rate. A RESET is not guaranteed to occur if VDD falls below VBOD for less than parameter (TBOD).

On any RESET (Power-on, Brown-out, Watchdog, etc.), the chip will remain in RESET until VDD rises above BVDD (see Figure 10-6). The Power-up Timer will now be invoked, if enabled, and will keep the chip in RESET an additional 72 ms.

Note: A Brown-out Detect does not enable the Power-up Timer if the PWRTE bit in the configuration word is set.

If VDD drops below BVDD while the Power-up Timer is running, the chip will go back into a Brown-out Detect and the Power-up Timer will be re-initialized. Once VDD rises above BVDD, the Power-up Timer will execute a 72 ms RESET.

FIGURE 10-6: BROWN-OUT SITUATIONS

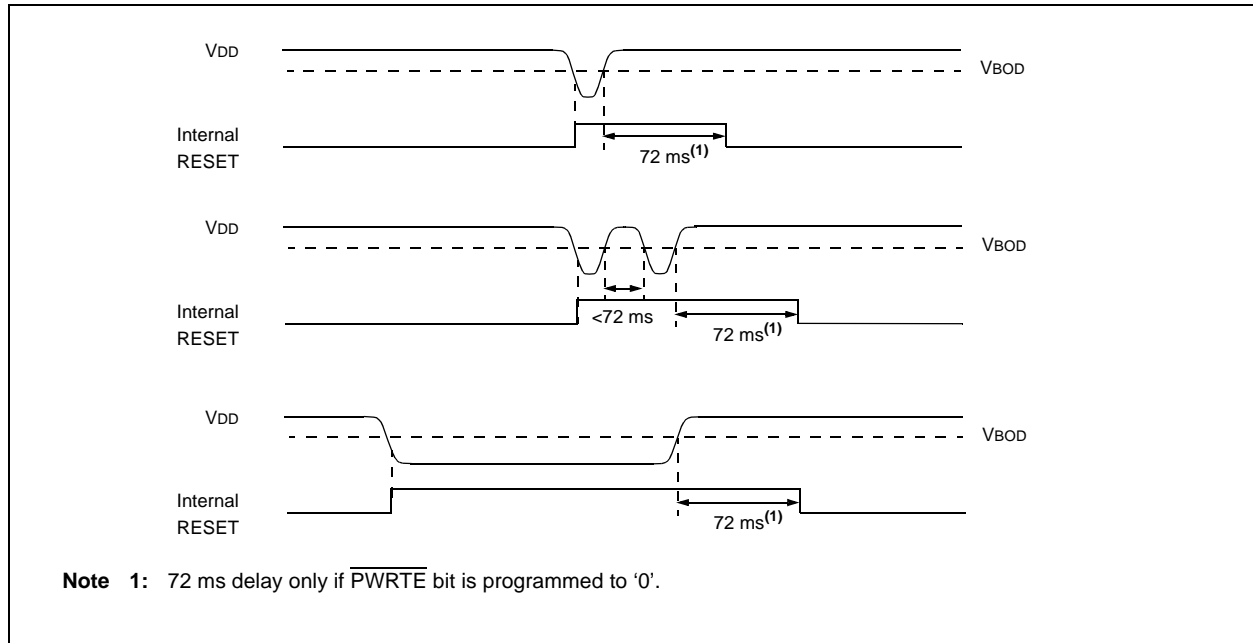

10.3.6 TIME-OUT SEQUENCE

On power-up, the time-out sequence is as follows: first, PWRT time-out is invoked after POR has expired. Then, OST is activated. The total time-out will vary based on oscillator configuration and $\overline{\text{PWRTE}}$ bit status. For example, in EC mode with $\overline{\text{PWRTE}}$ bit erased (PWRT disabled), there will be no time-out at all. Figure 10-7, Figure 10-8 and Figure 10-9 depict time-out sequences.

Since the time-outs occur from the POR pulse, if $\overline{\text{MCLR}}$ is kept low long enough, the time-outs will expire. Then bringing $\overline{\text{MCLR}}$ high will begin execution immediately (see Figure 10-8). This is useful for testing purposes or to synchronize more than one rfPIC12F675 device operating in parallel.

Table 10-6 shows the RESET conditions for some special registers, while Table 10-7 shows the RESET conditions for all the registers.

10.3.7 POWER CONTROL (PCON) STATUS REGISTER

The power CONTROL/STATUS register, PCON (address 8Eh) has two bits.

Bit0 is $\overline{\text{BOD}}$ (Brown-out). $\overline{\text{BOD}}$ is unknown on Power-on Reset. It must then be set by the user and checked on subsequent RESETS to see if $\overline{\text{BOD}} = 0$, indicating that a brown-out has occurred. The $\overline{\text{BOD}}$ STATUS bit is a don't care and is not necessarily predictable if the brown-out circuit is disabled (by setting BODEN bit = 0 in the Configuration word).

Bit1 is $\overline{\text{POR}}$ (Power-on Reset). It is a '0' on Power-on Reset and unaffected otherwise. The user must write a '1' to this bit following a Power-on Reset. On a subsequent RESET, if POR is '0', it will indicate that a Power-on Reset must have occurred (i.e., VDD may have gone too low).

rfPIC12F675

TABLE 10-3: TIME-OUT IN VARIOUS SITUATIONS

Oscillator Configuration	Power-up		Brown-out Detect		Wake-up from SLEEP
	$\overline{\text{PWRTE}} = 0$	$\overline{\text{PWRTE}} = 1$	$\overline{\text{PWRTE}} = 0$	$\overline{\text{PWRTE}} = 1$	
XT, HS, LP	TPWRT + 1024•TOSC	1024•TOSC	TPWRT + 1024•TOSC	1024•TOSC	1024•TOSC
RC, EC, INTOSC	TPWRT	—	TPWRT	—	—

TABLE 10-4: STATUS/PCON BITS AND THEIR SIGNIFICANCE

$\overline{\text{POR}}$	$\overline{\text{BOD}}$	$\overline{\text{TO}}$	$\overline{\text{PD}}$	
0	u	1	1	Power-on Reset
1	0	1	1	Brown-out Detect
u	u	0	u	WDT Reset
u	u	0	0	WDT Wake-up
u	u	u	u	$\overline{\text{MCLR}}$ Reset during normal operation
u	u	1	0	$\overline{\text{MCLR}}$ Reset during SLEEP

Legend: u = unchanged, x = unknown

TABLE 10-5: SUMMARY OF REGISTERS ASSOCIATED WITH BROWN-OUT

Address	Name	Bit 7	Bit 6	Bit 5	Bit 4	Bit 3	Bit 2	Bit 1	Bit 0	Value on POR, BOD	Value on all other RESETS ⁽¹⁾
03h	STATUS	IRP	RP1	RPO	$\overline{\text{TO}}$	$\overline{\text{PD}}$	Z	DC	C	0001 1xxx	000q quuu
8Eh	PCON	—	—	—	—	—	—	$\overline{\text{POR}}$	$\overline{\text{BOD}}$	---- --0x	---- --uq

Legend: u = unchanged, x = unknown, - = unimplemented bit, reads as '0', q = value depends on condition.

Note 1: Other (non Power-up) Resets include $\overline{\text{MCLR}}$ Reset, Brown-out Detect and Watchdog Timer Reset during normal operation.

TABLE 10-6: INITIALIZATION CONDITION FOR SPECIAL REGISTERS

Condition	Program Counter	STATUS Register	PCON Register
Power-on Reset	000h	0001 1xxx	---- --0x
$\overline{\text{MCLR}}$ Reset during normal operation	000h	000u uuuu	---- --uu
$\overline{\text{MCLR}}$ Reset during SLEEP	000h	0001 0uuu	---- --uu
WDT Reset	000h	0000 uuuu	---- --uu
WDT Wake-up	PC + 1	uuu0 0uuu	---- --uu
Brown-out Detect	000h	0001 1uuu	---- --10
Interrupt Wake-up from SLEEP	PC + 1 ⁽¹⁾	uuu1 0uuu	---- --uu

Legend: u = unchanged, x = unknown, - = unimplemented bit, reads as '0'.

Note 1: When the wake-up is due to an interrupt and global enable bit GIE is set, the PC is loaded with the interrupt vector (0004h) after execution of PC+1.

TABLE 10-7: INITIALIZATION CONDITION FOR REGISTERS

Register	Address	Power-on Reset	<ul style="list-style-type: none"> • MCLR Reset during normal operation • MCLR Reset during SLEEP • WDT Reset • Brown-out Detect⁽¹⁾ 	<ul style="list-style-type: none"> • Wake-up from SLEEP through interrupt • Wake-up from SLEEP through WDT time-out
W	—	xxxx xxxx	uuuu uuuu	uuuu uuuu
INDF	00h/80h	—	—	—
TMR0	01h	xxxx xxxx	uuuu uuuu	uuuu uuuu
PCL	02h/82h	0000 0000	0000 0000	PC + 1 ⁽³⁾
STATUS	03h/83h	0001 1xxx	000q quuu ⁽⁴⁾	uuuq quuu ⁽⁴⁾
FSR	04h/84h	xxxx xxxx	uuuu uuuu	uuuu uuuu
GPIO	05h	--xx xxxx	--uu uuuu	--uu uuuu
PCLATH	0Ah/8Ah	---0 0000	---0 0000	---u uuuu
INTCON	0Bh/8Bh	0000 0000	0000 000u	uuuu uuq ⁽²⁾
PIR1	0Ch	00-- 0--0	00-- 0--0	qq-- q--q ^(2,5)
T1CON	10h	-000 0000	-uuu uuuu	-uuu uuuu
CMCON	19h	-0-0 0000	-0-0 0000	-u-u uuuu
ADRESH	1Eh	xxxx xxxx	uuuu uuuu	uuuu uuuu
ADCON0	1Fh	00-- 0000	00-- 0000	uu-- uuuu
OPTION_REG	81h	1111 1111	1111 1111	uuuu uuuu
TRISIO	85h	--11 1111	--11 1111	--uu uuuu
PIE1	8Ch	00-- 0--0	00-- 0--0	uu-- u--u
PCON	8Eh	---- --0x	---- --uu ^(1,6)	---- --uu
OSCCAL	90h	1000 00--	1000 00--	uuuu uu--
WPU	95h	--11 -111	--11 -111	uuuu uuuu
IOC	96h	--00 0000	--00 0000	--uu uuuu
VRCON	99h	0-0- 0000	0-0- 0000	u-u- uuuu
EEDATA	9Ah	0000 0000	0000 0000	uuuu uuuu
EEADR	9Bh	-000 0000	-000 0000	-uuu uuuu
EECON1	9Ch	---- x000	---- q000	---- uuuu
EECON2	9Dh	---- ----	---- ----	---- ----
ADRESL	9Eh	xxxx xxxx	uuuu uuuu	uuuu uuuu
ANSEL	9Fh	-000 1111	-000 1111	-uuu uuuu

Legend: u = unchanged, x = unknown, - = unimplemented bit, reads as '0', q = value depends on condition.

- Note 1:** If VDD goes too low, Power-on Reset will be activated and registers will be affected differently.
- 2:** One or more bits in INTCON and/or PIR1 will be affected (to cause wake-up).
- 3:** When the wake-up is due to an interrupt and the GIE bit is set, the PC is loaded with the interrupt vector (0004h).
- 4:** See Table 10-6 for RESET value for specific condition.
- 5:** If wake-up was due to data EEPROM write completing, Bit 7 = 1; A/D conversion completing, Bit 6 = 1; Comparator input changing, bit 3 = 1; or Timer1 rolling over, bit 0 = 1. All other interrupts generating a wake-up will cause these bits to = u.
- 6:** If RESET was due to brown-out, then bit 0 = 0. All other RESETS will cause bit 0 = u.

rfPIC12F675

FIGURE 10-7: TIME-OUT SEQUENCE ON POWER-UP ($\overline{\text{MCLR}}$ NOT TIED TO V_{DD}): CASE 1

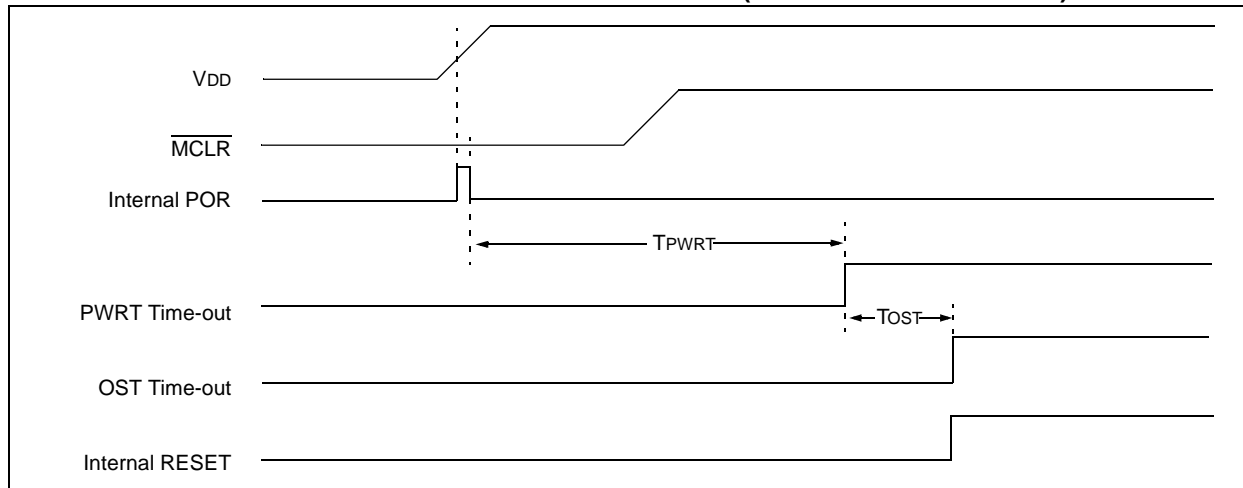

FIGURE 10-8: TIME-OUT SEQUENCE ON POWER-UP ($\overline{\text{MCLR}}$ NOT TIED TO V_{DD}): CASE 2

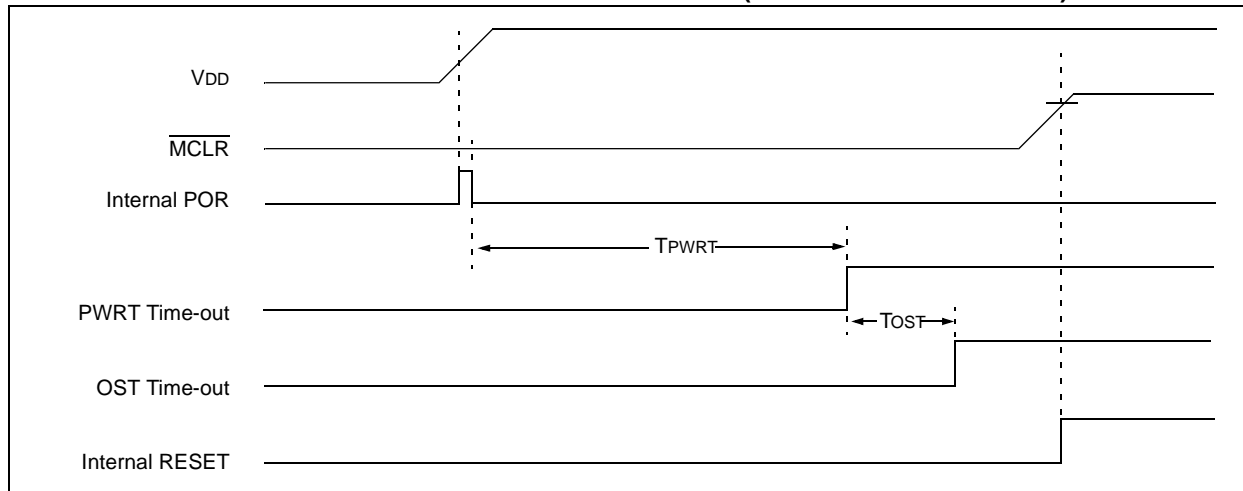
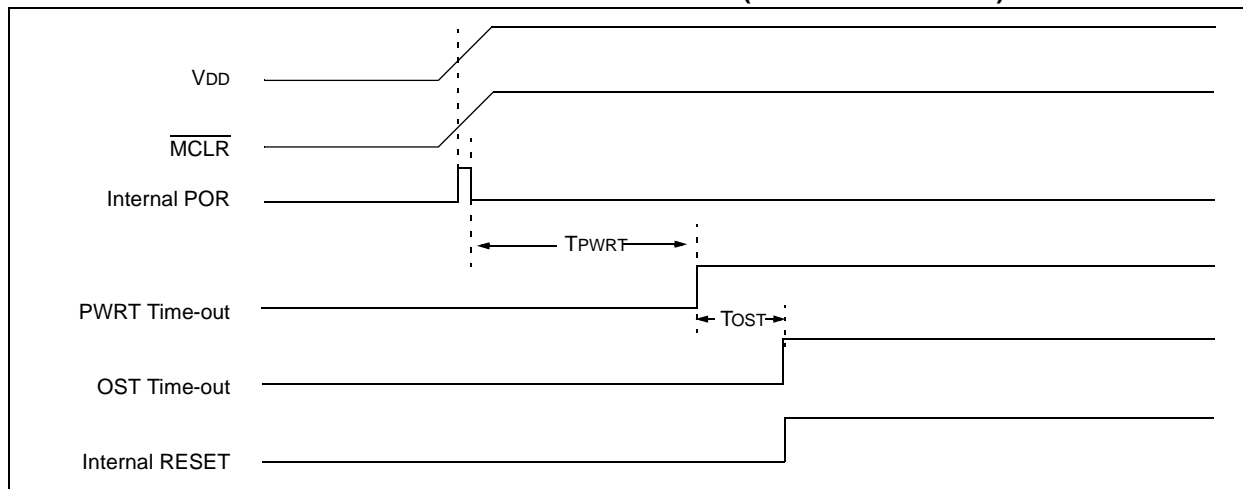

FIGURE 10-9: TIME-OUT SEQUENCE ON POWER-UP ($\overline{\text{MCLR}}$ TIED TO V_{DD})



10.4 Interrupts

The rfPIC12F675 has 7 sources of interrupt:

- External Interrupt GP2/INT
- TMR0 Overflow Interrupt
- GPIO Change Interrupts
- Comparator Interrupt
- A/D Interrupt
- TMR1 Overflow Interrupt
- EEPROM Data Write Interrupt

The Interrupt Control register (INTCON) and Peripheral Interrupt register (PIR) record individual interrupt requests in flag bits. The INTCON register also has individual and global interrupt enable bits.

A global interrupt enable bit, GIE (INTCON<7>) enables (if set) all unmasked interrupts, or disables (if cleared) all interrupts. Individual interrupts can be disabled through their corresponding enable bits in INTCON register and PIE register. GIE is cleared on RESET.

The return from interrupt instruction, RETFIE, exits interrupt routine, as well as sets the GIE bit, which re-enables unmasked interrupts.

The following interrupt flags are contained in the INTCON register:

- INT pin interrupt
- GP port change interrupt
- TMR0 overflow interrupt

The peripheral interrupt flags are contained in the special register PIR1. The corresponding interrupt enable bit is contained in Special Register PIE1.

The following interrupt flags are contained in the PIR register:

- EEPROM data write interrupt
- A/D interrupt
- Comparator interrupt
- Timer1 overflow interrupt

When an interrupt is serviced:

- The GIE is cleared to disable any further interrupt
- The return address is pushed onto the stack
- The PC is loaded with 0004h

Once in the Interrupt Service Routine, the source(s) of the interrupt can be determined by polling the interrupt flag bits. The interrupt flag bit(s) must be cleared in software before re-enabling interrupts to avoid GP2/INT recursive interrupts.

For external interrupt events, such as the INT pin, or GP port change interrupt, the interrupt latency will be three or four instruction cycles. The exact latency depends upon when the interrupt event occurs (see Figure 10-11). The latency is the same for one or two-cycle instructions. Once in the Interrupt Service Routine, the source(s) of the interrupt can be determined by polling the interrupt flag bits. The

interrupt flag bit(s) must be cleared in software before re-enabling interrupts to avoid multiple interrupt requests.

Note 1: Individual interrupt flag bits are set, regardless of the status of their corresponding mask bit or the GIE bit.

2: When an instruction that clears the GIE bit is executed, any interrupts that were pending for execution in the next cycle are ignored. The interrupts which were ignored are still pending to be serviced when the GIE bit is set again.

rfPIC12F675

FIGURE 10-10: INTERRUPT LOGIC

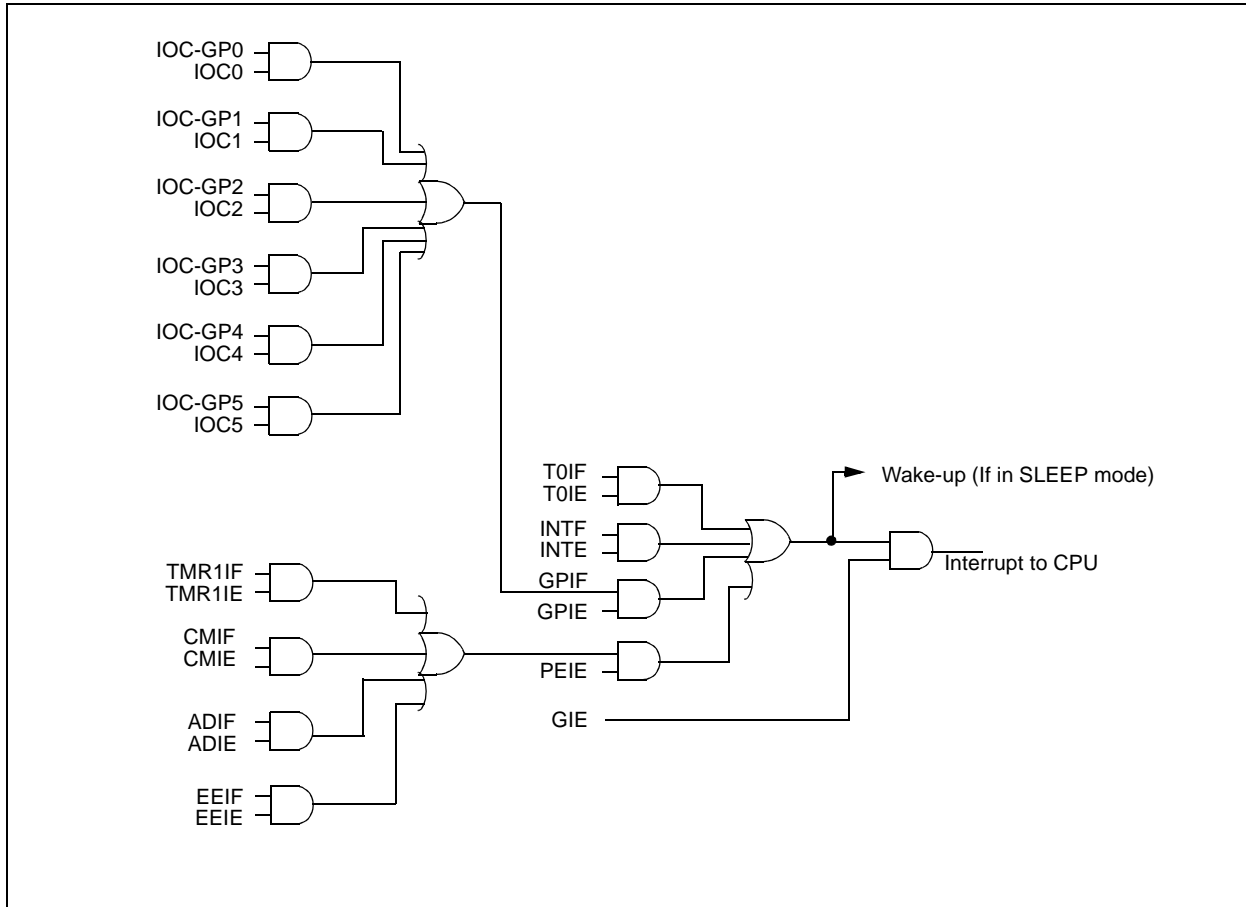

10.4.1 GP2/INT INTERRUPT

External interrupt on GP2/INT pin is edge-triggered; either rising if INTEDG bit (OPTION<6>) is set, of falling, if INTEDG bit is clear. When a valid edge appears on the GP2/INT pin, the INTF bit (INTCON<1>) is set. This interrupt can be disabled by clearing the INTE control bit (INTCON<4>). The INTF bit must be cleared in software in the Interrupt Service Routine before re-enabling this interrupt. The GP2/INT interrupt can wake-up the processor from SLEEP if the INTE bit was set prior to going into SLEEP. The status of the GIE bit decides whether or not the processor branches to the interrupt vector following wake-up. See Section 10.9 for details on SLEEP and Figure 10-13 for timing of wake-up from SLEEP through GP2/INT interrupt.

Note: The ANSEL (9Fh) and CMCON (19h) registers must be initialized to configure an analog channel as a digital input. Pins configured as analog inputs will read '0'.

10.4.2 TMR0 INTERRUPT

An overflow (FFh → 00h) in the TMR0 register will set the TOIF (INTCON<2>) bit. The interrupt can be enabled/disabled by setting/clearing T0IE (INTCON<5>) bit. For operation of the Timer0 module, see Section 4.0.

10.4.3 GPIO INTERRUPT

An input change on GPIO change sets the GPIF (INTCON<0>) bit. The interrupt can be enabled/disabled by setting/clearing the GPIE (INTCON<3>) bit. Plus individual pins can be configured through the IOC register.

Note: If a change on the I/O pin should occur when the read operation is being executed (start of the Q2 cycle), then the GPIF interrupt flag may not get set.

10.4.4 COMPARATOR INTERRUPT

See Section 6.9 for description of comparator interrupt.

10.4.5 A/D CONVERTER INTERRUPT

After a conversion is complete, the ADIF flag (PIR<6>) is set. The interrupt can be enabled/disabled by setting or clearing ADIE (PIE<6>).

See Section 7.0 for operation of the A/D converter interrupt.

FIGURE 10-11: INT PIN INTERRUPT TIMING

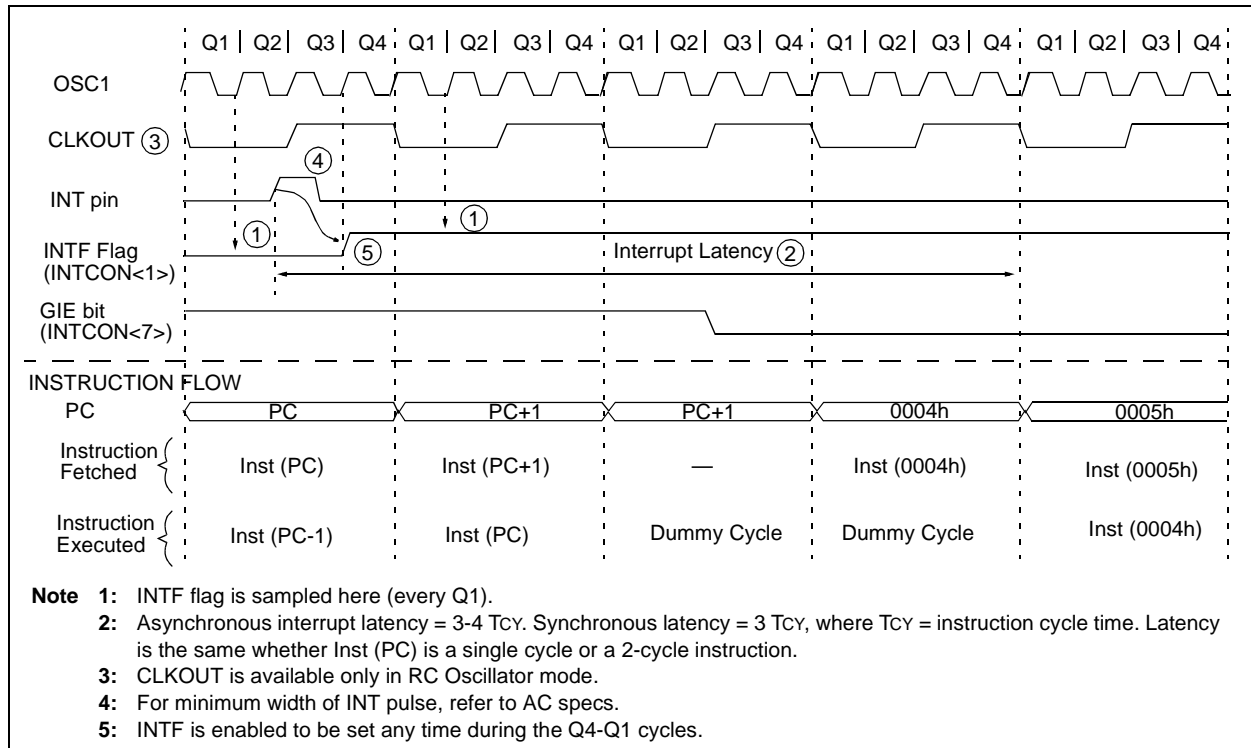

TABLE 10-8: SUMMARY OF INTERRUPT REGISTERS

Address	Name	Bit 7	Bit 6	Bit 5	Bit 4	Bit 3	Bit 2	Bit 1	Bit 0	Value on POR, BOD	Value on all other RESETS
0Bh, 8Bh	INTCON	GIE	PEIE	TOIE	INTE	GPIE	TOIF	INTF	GPIF	0000 0000	0000 000u
0Ch	PIR1	EEIF	ADIF	—	—	CMIF	—	—	TMR1IF	00-- 0--0	00-- 0--0
8Ch	PIE1	EEIE	ADIE	—	—	CMIE	—	—	TMR1IE	00-- 0--0	00-- 0--0

Legend: x = unknown, u = unchanged, - = unimplemented read as '0', q = value depends upon condition.
 Shaded cells are not used by the Interrupt module.

10.5 Context Saving During Interrupts

During an interrupt, only the return PC value is saved on the stack. Typically, users may wish to save key registers during an interrupt, (e.g., W register and STATUS register). This must be implemented in software.

Example 10-2 stores and restores the STATUS and W registers. The user register, W_TEMP, must be defined in both banks and must be defined at the same offset from the bank base address (i.e., W_TEMP is defined at 0x20 in Bank 0 and it must also be defined at 0xA0 in Bank 1). The user register, STATUS_TEMP, must be defined in Bank 0. The Example 10-2:

- Stores the W register
- Stores the STATUS register in Bank 0
- Executes the ISR code
- Restores the STATUS (and bank select bit register)
- Restores the W register

EXAMPLE 10-2: SAVING THE STATUS AND W REGISTERS IN RAM

MOVWF	W_TEMP	;copy W to temp register, could be in either bank
SWAPF	STATUS,W	;swap status to be saved into W
BCF	STATUS,RP0	;change to bank 0 regardless of current bank
MOVWF	STATUS_TEMP	;save status to bank 0 register
:	:	:
:	:(ISR)	:
:	:	:
SWAPF	STATUS_TEMP,W	;swap STATUS_TEMP register into W, sets bank to original state
MOVWF	STATUS	;move W into STATUS register
SWAPF	W_TEMP,F	;swap W_TEMP
SWAPF	W_TEMP,W	;swap W_TEMP into W

10.6 Watchdog Timer (WDT)

The Watchdog Timer is a free running, on-chip RC oscillator, which requires no external components. This RC oscillator is separate from the external RC oscillator of the CLKIN pin and INTOSC. That means that the WDT will run, even if the clock on the OSC1 and OSC2 pins of the device has been stopped (for example, by execution of a SLEEP instruction). During normal operation, a WDT time-out generates a device RESET. If the device is in SLEEP mode, a WDT time-out causes the device to wake-up and continue with normal operation. The WDT can be permanently disabled by programming the configuration bit WDTE as clear (Section 10.1).

10.6.1 WDT PERIOD

The WDT has a nominal time-out period of 18 ms, (with no prescaler). The time-out periods vary with temperature, VDD and process variations from part to part (see DC specs). If longer time-out periods are desired, a prescaler with a division ratio of up to 1:128 can be assigned to the WDT under software control by writing to the OPTION register. Thus, time-out periods up to 2.3 seconds can be realized.

The CLRWDT and SLEEP instructions clear the WDT and the prescaler, if assigned to the WDT, and prevent it from timing out and generating a device RESET.

The \overline{TO} bit in the STATUS register will be cleared upon a Watchdog Timer time-out.

10.6.2 WDT PROGRAMMING CONSIDERATIONS

It should also be taken in account that under worst case conditions (i.e., VDD = Min., Temperature = Max., Max. WDT prescaler) it may take several seconds before a WDT time-out occurs.

FIGURE 10-12: WATCHDOG TIMER BLOCK DIAGRAM

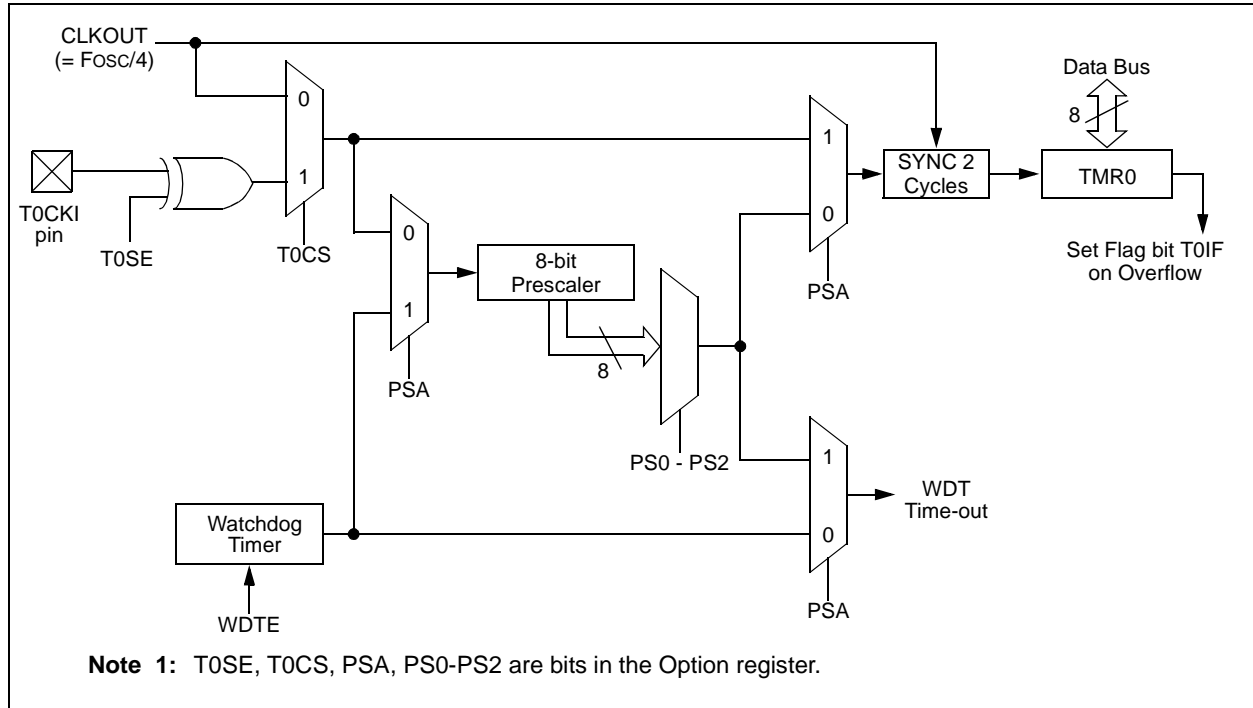

TABLE 10-9: SUMMARY OF WATCHDOG TIMER REGISTERS

Address	Name	Bit 7	Bit 6	Bit 5	Bit 4	Bit 3	Bit 2	Bit 1	Bit 0	Value on POR, BOD	Value on all other RESETS
81h	OPTION_REG	GPPU	INTEDG	T0CS	T0SE	PSA	PS2	PS1	PS0	1111 1111	1111 1111
2007h	Config. bits	CP	BODEN	MCLRE	PWRTE	WDTE	F0SC2	F0SC1	F0SC0	uuuu uuuu	uuuu uuuu

Legend: u = Unchanged, shaded cells are not used by the Watchdog Timer.

10.7 ID Locations

Four memory locations (2000h-2003h) are designated as ID locations where the user can store checksum or other code identification numbers. These locations are not accessible during normal execution but are readable and writable during Program/Verify. Only the Least Significant 7 bits of the ID locations are used.

10.8 Code Protection

If the code protection bit(s) have not been programmed, the on-chip program memory can be read out for verification purposes.

Note: The entire data EEPROM and FLASH program memory will be erased when the code protection is turned off. The INTOSC calibration data is also erased. See rfPIC12F675 Programming Specification for more information.

10.9 Power-Down Mode (SLEEP)

The Power-down mode is entered by executing a SLEEP instruction.

If the Watchdog Timer is enabled:

- \overline{WDT} will be cleared but keeps running
- \overline{PD} bit in the STATUS register is cleared
- \overline{TO} bit is set
- Oscillator driver is turned off
- I/O ports maintain the status they had before SLEEP was executed (driving high, low, or hi-impedance).

For lowest current consumption in this mode, all I/O pins should be either at VDD, or VSS, with no external circuitry drawing current from the I/O pin and the comparators and CVREF should be disabled. I/O pins that are hi-impedance inputs should be pulled high or low externally to avoid switching currents caused by floating inputs. The T0CKI input should also be at VDD or VSS for lowest current consumption. The contribution from on-chip pull-ups on GPIO should be considered.

The \overline{MCLR} pin must be at a logic high level (V_{IHMC}).

Note: It should be noted that a RESET generated by a WDT time-out does not drive \overline{MCLR} pin low.

1. External RESET input on \overline{MCLR} pin
2. Watchdog Timer Wake-up (if WDT was enabled)
3. Interrupt from GP2/INT pin, GPIO change, or a peripheral interrupt.

The first event will cause a device RESET. The two latter events are considered a continuation of program execution. The \overline{TO} and \overline{PD} bits in the STATUS register can be used to determine the cause of device RESET. The \overline{PD} bit, which is set on power-up, is cleared when SLEEP is invoked. \overline{TO} bit is cleared if WDT Wake-up occurred.

When the SLEEP instruction is being executed, the next instruction (PC + 1) is pre-fetched. For the device to wake-up through an interrupt event, the corresponding interrupt enable bit must be set (enabled). Wake-up is regardless of the state of the GIE bit. If the GIE bit is clear (disabled), the device continues execution at the instruction after the SLEEP instruction. If the GIE bit is set (enabled), the device executes the instruction after the SLEEP instruction, then branches to the interrupt address (0004h). In cases where the execution of the instruction following SLEEP is not desirable, the user should have a NOP after the SLEEP instruction.

Note: If the global interrupts are disabled (GIE is cleared), but any interrupt source has both its interrupt enable bit and the corresponding interrupt flag bits set, the device will immediately wake-up from SLEEP. The SLEEP instruction is completely executed.

10.9.1 WAKE-UP FROM SLEEP

The device can wake-up from SLEEP through one of the following events:

The WDT is cleared when the device wakes up from SLEEP, regardless of the source of wake-up.

FIGURE 10-13: WAKE-UP FROM SLEEP THROUGH INTERRUPT

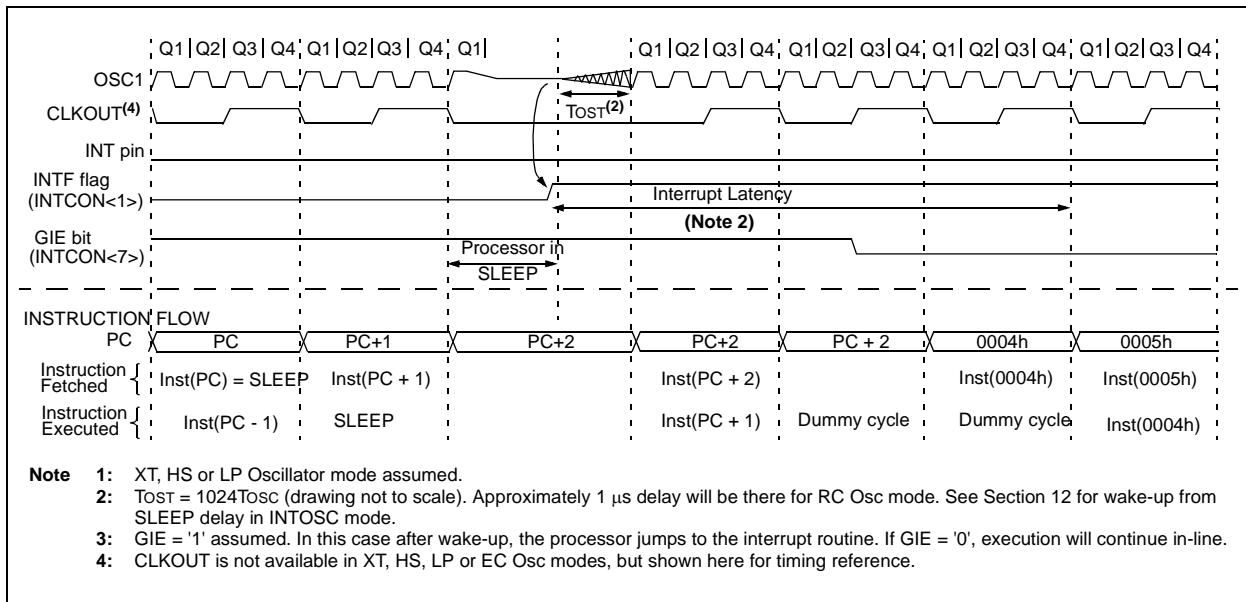
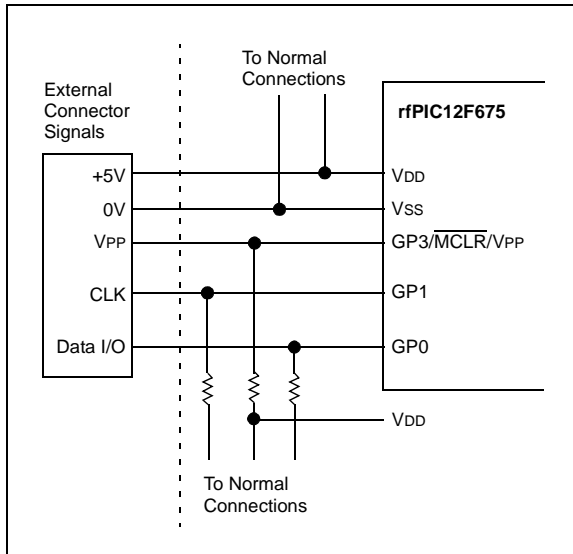

FIGURE 10-14: TYPICAL IN-CIRCUIT SERIAL PROGRAMMING CONNECTION



10.10 In-Circuit Serial Programming

The rfPIC12F675 microcontrollers can be serially programmed while in the end application circuit. This is done with two lines for clock and data, and three lines for power, ground, and programming voltage.

This allows customers to manufacture boards with unprogrammed devices, and then program the microcontroller before shipping the product. This also allows the most recent firmware or custom firmware to be programmed.

The device is placed into a Program/Verify mode by holding the GP0 and GP1 pins low, while raising the MCLR (VPP) pin from V_{IL} to V_{IHH} (see Programming Specification). GP0 becomes the programming data and GP1 becomes the programming clock. Both GP0 and GP1 are Schmitt Trigger inputs in this mode.

After RESET, to place the device into Programming/Verify mode, the program counter (PC) is at location 00h. A 6-bit command is then supplied to the device. Depending on the command, 14-bits of program data are then supplied to or from the device, depending on whether the command was a load or a read. For complete details of serial programming, please refer to the Programming Specifications document.

A typical In-Circuit Serial Programming connection is shown in Figure 10-14. The programming connections are isolated from conflicting outputs and capacitive loads by the 3 resistors. The VDD connection on MCLR may not be required if the pin is configured as GP3. Do not place sensitive circuitry on the GP3/MCLR pin without protection since the VPP signal goes well above VDD during programming.

FIGURE 10-15: PARALLEL DIP SOCKET FOR EMULATION

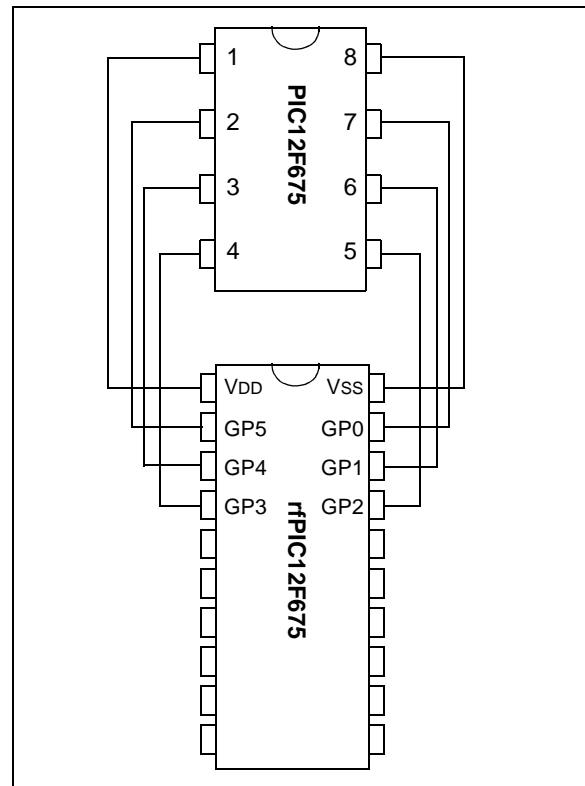

10.11 In-Circuit Debugging

Since in-circuit debugging requires the loss of clock, data and MCLR pins, MPLAB[®] ICD 2 development with an 8-pin microcontroller is not practical. Since the MPLAB ICE 2000 emulation module leads would be too long for the RF signals the following debug/emulation strategy is recommended.

Build a prototype board with all your digital, analog, and RF circuitry. Add an 8 pin DIP socket for the PIC12F675 debugging. Connect the socket as shown in Figure 10-15. When soldering the rfPIC12F675 down bend up pins 1-4 and 17-20 so that they do not contact the board. A PIC12F675 or emulation/debugging development tool can be plugged into the socket as in Figure 10-16.

This test method encourages RF development to start early, as soon as the firmware can toggle the RF enable and data lines. The socket can even be left in the final layout for in-circuit production programming. A simple method for programming is to solder all the rfPIC12F675 pins to the board and move the 8-pin DIP standoff from the MPLAB ICE 2000 emulator to connect the PCB to a programmer such as the Pro Mate[®] II or PICKit[™] 1 as in Figure 10-17.

There is an ICD 2 header interface board for the PIC12F675, part number AC162050. This special ICD module is mounted on the top of a header and its

rfPIC12F675

signals are routed to the MPLAB ICD 2 connector. On the bottom of the header is an 8-pin socket that plugs into the user's target via the 8-pin standoff connector.

When the $\overline{\text{ICD}}$ pin on the PIC12F675-ICD device is held low, the In-Circuit Debugger functionality is enabled. This function allows simple debugging functions when used with MPLAB ICD 2. When the microcontroller has this feature enabled, some of the resources are not available for general use. Table 10-10 shows resources consumed by the background debugger:

TABLE 10-10: DEBUGGER RESOURCES

I/O pins	ICDCLK, ICDDATA
Stack	1 level
Program Memory	Address 0h must be NOP 300h - 3FEh

For more information, see 8-Pin MPLAB ICD 2 Header Information Sheet (DS51292) available on Microchip's website (www.microchip.com).

FIGURE 10-16: IN-CIRCUIT DEBUGGING USING THE PARALLEL DIP SOCKET

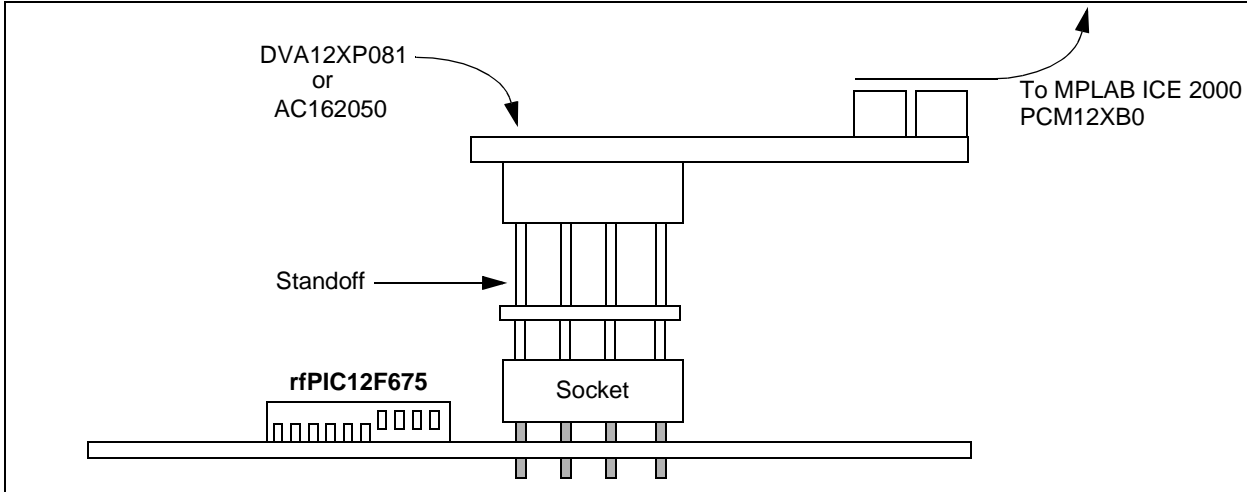
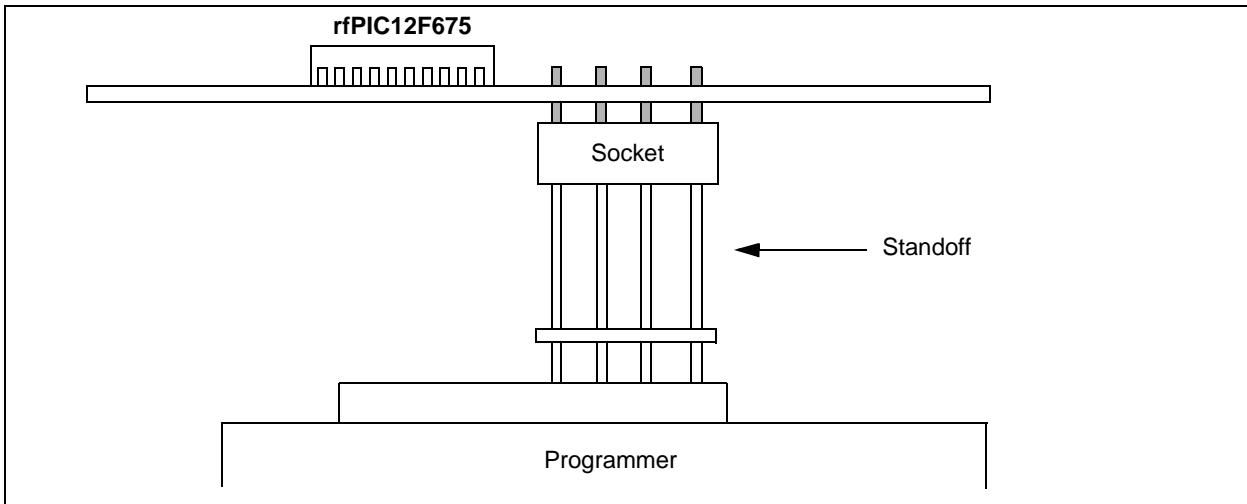

FIGURE 10-17: IN-CIRCUIT PROGRAMMING USING THE PARALLEL DIP SOCKET



11.0 INSTRUCTION SET SUMMARY

The rfPIC12F675 instruction set is highly orthogonal and is comprised of three basic categories:

- **Byte-oriented** operations
- **Bit-oriented** operations
- **Literal and control** operations

Each rfPIC12F675 instruction is a 14-bit word divided into an **opcode**, which specifies the instruction type, and one or more **operands**, which further specify the operation of the instruction. The formats for each of the categories is presented in Figure 11-1, while the various opcode fields are summarized in Table 11-1.

Table 11-2 lists the instructions recognized by the MPASM™ assembler. A complete description of each instruction is also available in the PIC *Mid-Range Reference Manual* (DS33023).

For **byte-oriented** instructions, 'f' represents a file register designator and 'd' represents a destination designator. The file register designator specifies which file register is to be used by the instruction.

The destination designator specifies where the result of the operation is to be placed. If 'd' is zero, the result is placed in the W register. If 'd' is one, the result is placed in the file register specified in the instruction.

For **bit-oriented** instructions, 'b' represents a bit field designator, which selects the bit affected by the operation, while 'f' represents the address of the file in which the bit is located.

For **literal and control** operations, 'k' represents an 8-bit or 11-bit constant, or literal value.

One instruction cycle consists of four oscillator periods; for an oscillator frequency of 4 MHz, this gives a normal instruction execution time of 1 μs. All instructions are executed within a single instruction cycle, unless a conditional test is true, or the program counter is changed as a result of an instruction. When this occurs, the execution takes two instruction cycles, with the second cycle executed as a NOP.

Note: To maintain upward compatibility with future products, do not use the `OPTION` and `TRISIO` instructions.

All instruction examples use the format '0xhh' to represent a hexadecimal number, where 'h' signifies a hexadecimal digit.

11.1 READ-MODIFY-WRITE OPERATIONS

Any instruction that specifies a file register as part of the instruction performs a Read-Modify-Write (R-M-W) operation. The register is read, the data is modified, and the result is stored according to either the instruction, or the destination designator 'd'. A read operation is performed on a register even if the instruction writes to that register.

For example, a `CLRF GPIO` instruction will read GPIO, clear all the data bits, then write the result back to GPIO. This example would have the unintended result that the condition that sets the GPIF flag would be cleared.

TABLE 11-1: OPCODE FIELD DESCRIPTIONS

Field	Description
f	Register file address (0x00 to 0x7F)
W	Working register (accumulator)
b	Bit address within an 8-bit file register
k	Literal field, constant data or label
x	Don't care location (= 0 or 1). The assembler will generate code with x = 0. It is the recommended form of use for compatibility with all Microchip software tools.
d	Destination select; d = 0: store result in W, d = 1: store result in file register f. Default is d = 1.
PC	Program Counter
TO	Time-out bit
PD	Power-down bit

FIGURE 11-1: GENERAL FORMAT FOR INSTRUCTIONS

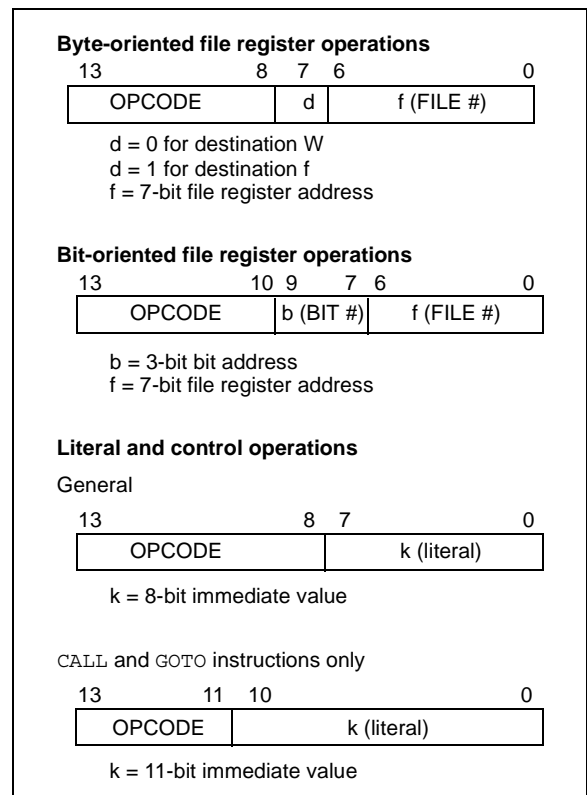

rfPIC12F675

TABLE 11-2: rfPIC12F675 INSTRUCTION SET

Mnemonic, Operands	Description	Cycles	14-Bit Opcode				Status Affected	Notes	
			MSb		LSb				
BYTE-ORIENTED FILE REGISTER OPERATIONS									
ADDWF	f, d	Add W and f	1	00	0111	dfff	ffff	C,DC,Z	1,2
ANDWF	f, d	AND W with f	1	00	0101	dfff	ffff	Z	1,2
CLRF	f	Clear f	1	00	0001	1fff	ffff	Z	2
CLRWF	-	Clear W	1	00	0001	0xxx	xxxx	Z	
COMF	f, d	Complement f	1	00	1001	dfff	ffff	Z	1,2
DECf	f, d	Decrement f	1	00	0011	dfff	ffff	Z	1,2
DECFSZ	f, d	Decrement f, Skip if 0	1(2)	00	1011	dfff	ffff		1,2,3
INCF	f, d	Increment f	1	00	1010	dfff	ffff	Z	1,2
INCFSZ	f, d	Increment f, Skip if 0	1(2)	00	1111	dfff	ffff		1,2,3
IORWF	f, d	Inclusive OR W with f	1	00	0100	dfff	ffff	Z	1,2
MOVF	f, d	Move f	1	00	1000	dfff	ffff	Z	1,2
MOVWF	f	Move W to f	1	00	0000	1fff	ffff		
NOP	-	No Operation	1	00	0000	0xx0	0000		
RLF	f, d	Rotate Left f through Carry	1	00	1101	dfff	ffff	C	1,2
RRF	f, d	Rotate Right f through Carry	1	00	1100	dfff	ffff	C	1,2
SUBWF	f, d	Subtract W from f	1	00	0010	dfff	ffff	C,DC,Z	1,2
SWAPF	f, d	Swap nibbles in f	1	00	1110	dfff	ffff		1,2
XORWF	f, d	Exclusive OR W with f	1	00	0110	dfff	ffff	Z	1,2
BIT-ORIENTED FILE REGISTER OPERATIONS									
BCF	f, b	Bit Clear f	1	01	00bb	bfff	ffff		1,2
BSF	f, b	Bit Set f	1	01	01bb	bfff	ffff		1,2
BTFSC	f, b	Bit Test f, Skip if Clear	1 (2)	01	10bb	bfff	ffff		3
BTFSS	f, b	Bit Test f, Skip if Set	1 (2)	01	11bb	bfff	ffff		3
LITERAL AND CONTROL OPERATIONS									
ADDLW	k	Add literal and W	1	11	111x	kkkk	kkkk	C,DC,Z	
ANDLW	k	AND literal with W	1	11	1001	kkkk	kkkk	Z	
CALL	k	Call subroutine	2	10	0kkk	kkkk	kkkk		
CLRWD _T	-	Clear Watchdog Timer	1	00	0000	0110	0100	$\overline{TO,PD}$	
GOTO	k	Go to address	2	10	1kkk	kkkk	kkkk		
IORLW	k	Inclusive OR literal with W	1	11	1000	kkkk	kkkk	Z	
MOVLW	k	Move literal to W	1	11	00xx	kkkk	kkkk		
RETFIE	-	Return from interrupt	2	00	0000	0000	1001		
RETLW	k	Return with literal in W	2	11	01xx	kkkk	kkkk		
RETURN	-	Return from Subroutine	2	00	0000	0000	1000		
SLEEP	-	Go into Standby mode	1	00	0000	0110	0011	$\overline{TO,PD}$	
SUBLW	k	Subtract W from literal	1	11	110x	kkkk	kkkk	C,DC,Z	
XORLW	k	Exclusive OR literal with W	1	11	1010	kkkk	kkkk	Z	

- Note 1:** When an I/O register is modified as a function of itself (e.g., `MOVF GPIO, 1`), the value used will be that value present on the pins themselves. For example, if the data latch is '1' for a pin configured as input and is driven low by an external device, the data will be written back with a '0'.
- 2:** If this instruction is executed on the TMR0 register (and, where applicable, $d = 1$), the prescaler will be cleared if assigned to the Timer0 module.
- 3:** If Program Counter (PC) is modified, or a conditional test is true, the instruction requires two cycles. The second cycle is executed as a NOP.

Note: Additional information on the mid-range instruction set is available in the *PIC Mid-Range MCU Family Reference Manual* (DS33023).

11.2 Instruction Descriptions

ADDLW **Add Literal and W**

Syntax: *[label]* ADDLW *k*
Operands: $0 \leq k \leq 255$
Operation: $(W) + k \rightarrow (W)$
Status Affected: C, DC, Z
Description: The contents of the W register are added to the eight-bit literal 'k' and the result is placed in the W register.

ADDWF **Add W and f**

Syntax: *[label]* ADDWF *f,d*
Operands: $0 \leq f \leq 127$
 $d \in [0,1]$
Operation: $(W) + (f) \rightarrow (\text{destination})$
Status Affected: C, DC, Z
Description: Add the contents of the W register with register 'f'. If 'd' is 0, the result is stored in the W register. If 'd' is 1, the result is stored back in register 'f'.

ANDLW **AND Literal with W**

Syntax: *[label]* ANDLW *k*
Operands: $0 \leq k \leq 255$
Operation: $(W) .\text{AND.} (k) \rightarrow (W)$
Status Affected: Z
Description: The contents of W register are AND'ed with the eight-bit literal 'k'. The result is placed in the W register.

ANDWF **AND W with f**

Syntax: *[label]* ANDWF *f,d*
Operands: $0 \leq f \leq 127$
 $d \in [0,1]$
Operation: $(W) .\text{AND.} (f) \rightarrow (\text{destination})$
Status Affected: Z
Description: AND the W register with register 'f'. If 'd' is 0, the result is stored in the W register. If 'd' is 1, the result is stored back in register 'f'.

BCF **Bit Clear f**

Syntax: *[label]* BCF *f,b*
Operands: $0 \leq f \leq 127$
 $0 \leq b \leq 7$
Operation: $0 \rightarrow (f)$
Status Affected: None
Description: Bit 'b' in register 'f' is cleared.

BSF **Bit Set f**

Syntax: *[label]* BSF *f,b*
Operands: $0 \leq f \leq 127$
 $0 \leq b \leq 7$
Operation: $1 \rightarrow (f)$
Status Affected: None
Description: Bit 'b' in register 'f' is set.

BTFSS **Bit Test f, Skip if Set**

Syntax: *[label]* BTFSS *f,b*
Operands: $0 \leq f \leq 127$
 $0 \leq b < 7$
Operation: skip if $(f) = 1$
Status Affected: None
Description: If bit 'b' in register 'f' is '0', the next instruction is executed. If bit 'b' is '1', then the next instruction is discarded and a NOP is executed instead, making this a 2TCY instruction.

BTFSC **Bit Test, Skip if Clear**

Syntax: *[label]* BTFSC *f,b*
Operands: $0 \leq f \leq 127$
 $0 \leq b \leq 7$
Operation: skip if $(f) = 0$
Status Affected: None
Description: If bit 'b' in register 'f' is '1', the next instruction is executed. If bit 'b', in register 'f', is '0', the next instruction is discarded, and a NOP is executed instead, making this a 2TCY instruction.

rfPIC12F675

CALL **Call Subroutine**

Syntax: [*label*] CALL *k*
Operands: $0 \leq k \leq 2047$
Operation: (PC)+ 1 → TOS,
 k → PC<10:0>,
 (PCLATH<4:3>) → PC<12:11>
Status Affected: None
Description: Call Subroutine. First, return address (PC+1) is pushed onto the stack. The eleven-bit immediate address is loaded into PC bits <10:0>. The upper bits of the PC are loaded from PCLATH. CALL is a two-cycle instruction.

CLRWDT **Clear Watchdog Timer**

Syntax: [*label*] CLRWDT
Operands: None
Operation: 00h → WDT
 0 → WDT prescaler,
 1 → \overline{TO}
 1 → \overline{PD}
Status Affected: \overline{TO} , \overline{PD}
Description: CLRWDT instruction resets the Watchdog Timer. It also resets the prescaler of the WDT. STATUS bits \overline{TO} and \overline{PD} are set.

CLRF **Clear f**

Syntax: [*label*] CLRF *f*
Operands: $0 \leq f \leq 127$
Operation: 00h → (*f*)
 1 → Z
Status Affected: Z
Description: The contents of register 'f' are cleared and the Z bit is set.

COMF **Complement f**

Syntax: [*label*] COMF *f*,*d*
Operands: $0 \leq f \leq 127$
 d ∈ [0,1]
Operation: (\bar{f}) → (destination)
Status Affected: Z
Description: The contents of register 'f' are complemented. If 'd' is 0, the result is stored in W. If 'd' is 1, the result is stored back in register 'f'.

CLRW **Clear W**

Syntax: [*label*] CLRW
Operands: None
Operation: 00h → (W)
 1 → Z
Status Affected: Z
Description: W register is cleared. Zero bit (Z) is set.

DECF **Decrement f**

Syntax: [*label*] DECF *f*,*d*
Operands: $0 \leq f \leq 127$
 d ∈ [0,1]
Operation: (*f*) - 1 → (destination)
Status Affected: Z
Description: Decrement register 'f'. If 'd' is 0, the result is stored in the W register. If 'd' is 1, the result is stored back in register 'f'.

DECFSZ Decrement f, Skip if 0

Syntax: [*label*] DECFSZ f,d

Operands: $0 \leq f \leq 127$
 $d \in [0,1]$

Operation: (f) - 1 → (destination);
 skip if result = 0

Status Affected: None

Description: The contents of register 'f' are decremented. If 'd' is 0, the result is placed in the W register. If 'd' is 1, the result is placed back in register 'f'.
 If the result is 1, the next instruction is executed. If the result is 0, then a NOP is executed instead, making it a 2TCY instruction.

INCFSZ Increment f, Skip if 0

Syntax: [*label*] INCFSZ f,d

Operands: $0 \leq f \leq 127$
 $d \in [0,1]$

Operation: (f) + 1 → (destination),
 skip if result = 0

Status Affected: None

Description: The contents of register 'f' are incremented. If 'd' is 0, the result is placed in the W register. If 'd' is 1, the result is placed back in register 'f'.
 If the result is 1, the next instruction is executed. If the result is 0, a NOP is executed instead, making it a 2TCY instruction.

GOTO Unconditional Branch

Syntax: [*label*] GOTO k

Operands: $0 \leq k \leq 2047$

Operation: $k \rightarrow PC<10:0>$
 $PCLATH<4:3> \rightarrow PC<12:11>$

Status Affected: None

Description: GOTO is an unconditional branch. The eleven-bit immediate value is loaded into PC bits <10:0>. The upper bits of PC are loaded from PCLATH<4:3>. GOTO is a two-cycle instruction.

IORLW Inclusive OR Literal with W

Syntax: [*label*] IORLW k

Operands: $0 \leq k \leq 255$

Operation: (W) .OR. k → (W)

Status Affected: Z

Description: The contents of the W register are OR'ed with the eight-bit literal 'k'. The result is placed in the W register.

INCF Increment f

Syntax: [*label*] INCF f,d

Operands: $0 \leq f \leq 127$
 $d \in [0,1]$

Operation: (f) + 1 → (destination)

Status Affected: Z

Description: The contents of register 'f' are incremented. If 'd' is 0, the result is placed in the W register. If 'd' is 1, the result is placed back in register 'f'.

IORWF Inclusive OR W with f

Syntax: [*label*] IORWF f,d

Operands: $0 \leq f \leq 127$
 $d \in [0,1]$

Operation: (W) .OR. (f) → (destination)

Status Affected: Z

Description: Inclusive OR the W register with register 'f'. If 'd' is 0, the result is placed in the W register. If 'd' is 1, the result is placed back in register 'f'.

rfPIC12F675

MOVF **Move f**

Syntax: [*label*] MOVF f,d
Operands: $0 \leq f \leq 127$
 $d \in [0,1]$
Operation: (f) → (destination)
Status Affected: Z
Description: The contents of register f are moved to a destination dependant upon the status of d. If d = 0, destination is W register. If d = 1, the destination is file register f itself. d = 1 is useful to test a file register, since status flag Z is affected.

NOP **No Operation**

Syntax: [*label*] NOP
Operands: None
Operation: No operation
Status Affected: None
Description: No operation.

MOVLW **Move Literal to W**

Syntax: [*label*] MOVLW k
Operands: $0 \leq k \leq 255$
Operation: $k \rightarrow (W)$
Status Affected: None
Description: The eight-bit literal 'k' is loaded into W register. The don't cares will assemble as 0's.

RETIE **Return from Interrupt**

Syntax: [*label*] RETIE
Operands: None
Operation: TOS → PC,
 1 → GIE
Status Affected: None

MOVWF **Move W to f**

Syntax: [*label*] MOVWF f
Operands: $0 \leq f \leq 127$
Operation: (W) → (f)
Status Affected: None
Description: Move data from W register to register 'f'.

RETLW **Return with Literal in W**

Syntax: [*label*] RETLW k
Operands: $0 \leq k \leq 255$
Operation: $k \rightarrow (W)$;
 TOS → PC
Status Affected: None
Description: The W register is loaded with the eight-bit literal 'k'. The program counter is loaded from the top of the stack (the return address). This is a two-cycle instruction.

RLF Rotate Left f through Carry

Syntax: [*label*] RLF f,d

Operands: $0 \leq f \leq 127$
 $d \in [0,1]$

Operation: See description below

Status Affected: C

Description: The contents of register 'f' are rotated one bit to the left through the Carry Flag. If 'd' is 0, the result is placed in the W register. If 'd' is 1, the result is stored back in register 'f'.

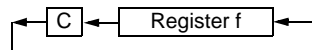

SLEEP

Syntax: [*label*] SLEEP

Operands: None

Operation: 00h → WDT,
 0 → WDT prescaler,
 1 → \overline{TO} ,
 0 → \overline{PD}

Status Affected: \overline{TO} , \overline{PD}

Description: The power-down STATUS bit, \overline{PD} is cleared. Time-out STATUS bit, \overline{TO} is set. Watchdog Timer and its prescaler are cleared. The processor is put into SLEEP mode with the oscillator stopped.

RETURN Return from Subroutine

Syntax: [*label*] RETURN

Operands: None

Operation: TOS → PC

Status Affected: None

Description: Return from subroutine. The stack is POPed and the top of the stack (TOS) is loaded into the program counter. This is a two-cycle instruction.

SUBLW Subtract W from Literal

Syntax: [*label*] SUBLW k

Operands: $0 \leq k \leq 255$

Operation: $k - (W) \rightarrow (W)$

Status Affected: C, DC, Z

Description: The W register is subtracted (2's complement method) from the eight-bit literal 'k'. The result is placed in the W register.

RRF Rotate Right f through Carry

Syntax: [*label*] RRF f,d

Operands: $0 \leq f \leq 127$
 $d \in [0,1]$

Operation: See description below

Status Affected: C

Description: The contents of register 'f' are rotated one bit to the right through the Carry Flag. If 'd' is 0, the result is placed in the W register. If 'd' is 1, the result is placed back in register 'f'.

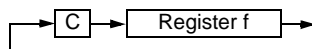

SUBWF Subtract W from f

Syntax: [*label*] SUBWF f,d

Operands: $0 \leq f \leq 127$
 $d \in [0,1]$

Operation: $(f) - (W) \rightarrow (\text{destination})$

Status Affected: C, DC, Z

Description: Subtract (2's complement method) W register from register 'f'. If 'd' is 0, the result is stored in the W register. If 'd' is 1, the result is stored back in register 'f'.

rfPIC12F675

SWAPF **Swap Nibbles in f**

Syntax: `[label] SWAPF f,d`

Operands: $0 \leq f \leq 127$
 $d \in [0,1]$

Operation: $(f<3:0>) \rightarrow (\text{destination}<7:4>)$,
 $(f<7:4>) \rightarrow (\text{destination}<3:0>)$

Status Affected: None

Description: The upper and lower nibbles of register 'f' are exchanged. If 'd' is 0, the result is placed in the W register. If 'd' is 1, the result is placed in register 'f'.

XORWF **Exclusive OR W with f**

Syntax: `[label] XORWF f,d`

Operands: $0 \leq f \leq 127$
 $d \in [0,1]$

Operation: $(W) .XOR. (f) \rightarrow (\text{destination})$

Status Affected: Z

Description: Exclusive OR the contents of the W register with register 'f'. If 'd' is 0, the result is stored in the W register. If 'd' is 1, the result is stored back in register 'f'.

XORLW **Exclusive OR Literal with W**

Syntax: `[label] XORLW k`

Operands: $0 \leq k \leq 255$

Operation: $(W) .XOR. k \rightarrow (W)$

Status Affected: Z

Description: The contents of the W register are XOR'ed with the eight-bit literal 'k'. The result is placed in the W register.

12.0 DEVELOPMENT SUPPORT

The PIC[®] microcontrollers are supported with a full range of hardware and software development tools:

- Integrated Development Environment
 - MPLAB[®] IDE Software
- Assemblers/Compilers/Linkers
 - MPASM[™] Assembler
 - MPLAB C17 and MPLAB C18 C Compilers
 - MPLINK[™] Object Linker/
MPLIB[™] Object Librarian
 - MPLAB C30 C Compiler
 - MPLAB ASM30 Assembler/Linker/Library
- Simulators
 - MPLAB SIM Software Simulator
 - MPLAB dsPIC30 Software Simulator
- Emulators
 - MPLAB ICE 2000 In-Circuit Emulator
 - MPLAB ICE 4000 In-Circuit Emulator
- In-Circuit Debugger
 - MPLAB ICD 2
- Device Programmers
 - PRO MATE[®] II Universal Device Programmer
 - PICSTART[®] Plus Development Programmer
- Low Cost Demonstration Boards
 - PICDEM[™] 1 Demonstration Board
 - PICDEM.net[™] Demonstration Board
 - PICDEM 2 Plus Demonstration Board
 - PICDEM 3 Demonstration Board
 - PICDEM 4 Demonstration Board
 - PICDEM 17 Demonstration Board
 - PICDEM 18R Demonstration Board
 - PICDEM LIN Demonstration Board
 - PICDEM USB Demonstration Board
- Evaluation Kits
 - KEELOQ[®]
 - PICDEM MSC
 - microID[®]
 - CAN
 - PowerSmart[®]
 - Analog

12.1 MPLAB Integrated Development Environment Software

The MPLAB IDE software brings an ease of software development previously unseen in the 8/16-bit microcontroller market. The MPLAB IDE is a Windows[®] based application that contains:

- An interface to debugging tools
 - simulator
 - programmer (sold separately)
 - emulator (sold separately)
 - in-circuit debugger (sold separately)
- A full-featured editor with color coded context
- A multiple project manager
- Customizable data windows with direct edit of contents
- High level source code debugging
- Mouse over variable inspection
- Extensive on-line help

The MPLAB IDE allows you to:

- Edit your source files (either assembly or C)
- One touch assemble (or compile) and download to PIC MCU emulator and simulator tools (automatically updates all project information)
- Debug using:
 - source files (assembly or C)
 - absolute listing file (mixed assembly and C)
 - machine code

MPLAB IDE supports multiple debugging tools in a single development paradigm, from the cost effective simulators, through low cost in-circuit debuggers, to full-featured emulators. This eliminates the learning curve when upgrading to tools with increasing flexibility and power.

12.2 MPASM Assembler

The MPASM assembler is a full-featured, universal macro assembler for all PIC MCUs.

The MPASM assembler generates relocatable object files for the MPLINK object linker, Intel[®] standard HEX files, MAP files to detail memory usage and symbol reference, absolute LST files that contain source lines and generated machine code and COFF files for debugging.

The MPASM assembler features include:

- Integration into MPLAB IDE projects
- User defined macros to streamline assembly code
- Conditional assembly for multi-purpose source files
- Directives that allow complete control over the assembly process

12.3 MPLAB C17 and MPLAB C18 C Compilers

The MPLAB C17 and MPLAB C18 Code Development Systems are complete ANSI C compilers for Microchip's PIC17CXXX and PIC18CXXX family of microcontrollers. These compilers provide powerful integration capabilities, superior code optimization and ease of use not found with other compilers.

For easy source level debugging, the compilers provide symbol information that is optimized to the MPLAB IDE debugger.

12.4 MPLINK Object Linker/ MPLIB Object Librarian

The MPLINK object linker combines relocatable objects created by the MPASM assembler and the MPLAB C17 and MPLAB C18 C compilers. It can link relocatable objects from pre-compiled libraries, using directives from a linker script.

The MPLIB object librarian manages the creation and modification of library files of pre-compiled code. When a routine from a library is called from a source file, only the modules that contain that routine will be linked in with the application. This allows large libraries to be used efficiently in many different applications.

The object linker/library features include:

- Efficient linking of single libraries instead of many smaller files
- Enhanced code maintainability by grouping related modules together
- Flexible creation of libraries with easy module listing, replacement, deletion and extraction

12.5 MPLAB C30 C Compiler

The MPLAB C30 C compiler is a full-featured, ANSI compliant, optimizing compiler that translates standard ANSI C programs into dsPIC30F assembly language source. The compiler also supports many command-line options and language extensions to take full advantage of the dsPIC30F device hardware capabilities, and afford fine control of the compiler code generator.

MPLAB C30 is distributed with a complete ANSI C standard library. All library functions have been validated and conform to the ANSI C library standard. The library includes functions for string manipulation, dynamic memory allocation, data conversion, timekeeping, and math functions (trigonometric, exponential and hyperbolic). The compiler provides symbolic information for high level source debugging with the MPLAB IDE.

12.6 MPLAB ASM30 Assembler, Linker, and Librarian

MPLAB ASM30 assembler produces relocatable machine code from symbolic assembly language for dsPIC30F devices. MPLAB C30 compiler uses the assembler to produce its object file. The assembler generates relocatable object files that can then be archived or linked with other relocatable object files and archives to create an executable file. Notable features of the assembler include:

- Support for the entire dsPIC30F instruction set
- Support for fixed-point and floating-point data
- Command line interface
- Rich directive set
- Flexible macro language
- MPLAB IDE compatibility

12.7 MPLAB SIM Software Simulator

The MPLAB SIM software simulator allows code development in a PC hosted environment by simulating the PIC series microcontrollers on an instruction level. On any given instruction, the data areas can be examined or modified and stimuli can be applied from a file, or user defined key press, to any pin. The execution can be performed in Single-Step, Execute Until Break, or Trace mode.

The MPLAB SIM simulator fully supports symbolic debugging using the MPLAB C17 and MPLAB C18 C Compilers, as well as the MPASM assembler. The software simulator offers the flexibility to develop and debug code outside of the laboratory environment, making it an excellent, economical software development tool.

12.8 MPLAB SIM30 Software Simulator

The MPLAB SIM30 software simulator allows code development in a PC hosted environment by simulating the dsPIC30F series microcontrollers on an instruction level. On any given instruction, the data areas can be examined or modified and stimuli can be applied from a file, or user defined key press, to any of the pins.

The MPLAB SIM30 simulator fully supports symbolic debugging using the MPLAB C30 C Compiler and MPLAB ASM30 assembler. The simulator runs in either a Command Line mode for automated tasks, or from MPLAB IDE. This high speed simulator is designed to debug, analyze and optimize time intensive DSP routines.

12.9 MPLAB ICE 2000 High Performance Universal In-Circuit Emulator

The MPLAB ICE 2000 universal in-circuit emulator is intended to provide the product development engineer with a complete microcontroller design tool set for PIC microcontrollers. Software control of the MPLAB ICE 2000 in-circuit emulator is advanced by the MPLAB Integrated Development Environment, which allows editing, building, downloading and source debugging from a single environment.

The MPLAB ICE 2000 is a full-featured emulator system with enhanced trace, trigger and data monitoring features. Interchangeable processor modules allow the system to be easily reconfigured for emulation of different processors. The universal architecture of the MPLAB ICE in-circuit emulator allows expansion to support new PIC microcontrollers.

The MPLAB ICE 2000 in-circuit emulator system has been designed as a real-time emulation system with advanced features that are typically found on more expensive development tools. The PC platform and Microsoft® Windows 32-bit operating system were chosen to best make these features available in a simple, unified application.

12.10 MPLAB ICE 4000 High Performance Universal In-Circuit Emulator

The MPLAB ICE 4000 universal in-circuit emulator is intended to provide the product development engineer with a complete microcontroller design tool set for high-end PIC microcontrollers. Software control of the MPLAB ICE in-circuit emulator is provided by the MPLAB Integrated Development Environment, which allows editing, building, downloading and source debugging from a single environment.

The MPLAB ICE 4000 is a premium emulator system, providing the features of MPLAB ICE 2000, but with increased emulation memory and high speed performance for dsPIC30F and PIC18XXX devices. Its advanced emulator features include complex triggering and timing, up to 2 Mb of emulation memory, and the ability to view variables in real-time.

The MPLAB ICE 4000 in-circuit emulator system has been designed as a real-time emulation system with advanced features that are typically found on more expensive development tools. The PC platform and Microsoft Windows 32-bit operating system were chosen to best make these features available in a simple, unified application.

12.11 MPLAB ICD 2 In-Circuit Debugger

Microchip's In-Circuit Debugger, MPLAB ICD 2, is a powerful, low cost, run-time development tool, connecting to the host PC via an RS-232 or high speed USB interface. This tool is based on the FLASH PIC MCUs and can be used to develop for these and other PIC microcontrollers. The MPLAB ICD 2 utilizes the in-circuit debugging capability built into the FLASH devices. This feature, along with Microchip's In-Circuit Serial Programming™ (ICSP™) protocol, offers cost effective in-circuit FLASH debugging from the graphical user interface of the MPLAB Integrated Development Environment. This enables a designer to develop and debug source code by setting breakpoints, single-stepping and watching variables, CPU status and peripheral registers. Running at full speed enables testing hardware and applications in real-time. MPLAB ICD 2 also serves as a development programmer for selected PIC devices.

12.12 PRO MATE II Universal Device Programmer

The PRO MATE II is a universal, CE compliant device programmer with programmable voltage verification at VDDMIN and VDDMAX for maximum reliability. It features an LCD display for instructions and error messages and a modular detachable socket assembly to support various package types. In Stand-Alone mode, the PRO MATE II device programmer can read, verify, and program PIC devices without a PC connection. It can also set code protection in this mode.

12.13 PICSTART Plus Development Programmer

The PICSTART Plus development programmer is an easy-to-use, low cost, prototype programmer. It connects to the PC via a COM (RS-232) port. MPLAB Integrated Development Environment software makes using the programmer simple and efficient. The PICSTART Plus development programmer supports most PIC devices up to 40 pins. Larger pin count devices, such as the PIC16C92X and PIC17C76X, may be supported with an adapter socket. The PICSTART Plus development programmer is CE compliant.

12.14 PICDEM 1 PIC MCU Demonstration Board

The PICDEM 1 demonstration board demonstrates the capabilities of the PIC16C5X (PIC16C54 to PIC16C58A), PIC16C61, PIC16C62X, PIC16C71, PIC16C8X, PIC17C42, PIC17C43 and PIC17C44. All necessary hardware and software is included to run basic demo programs. The sample microcontrollers provided with the PICDEM 1 demonstration board can be programmed with a PRO MATE II device programmer, or a PICSTART Plus development programmer. The PICDEM 1 demonstration board can be connected to the MPLAB ICE in-circuit emulator for testing. A prototype area extends the circuitry for additional application components. Features include an RS-232 interface, a potentiometer for simulated analog input, push button switches and eight LEDs.

12.15 PICDEM.net Internet/Ethernet Demonstration Board

The PICDEM.net demonstration board is an Internet/Ethernet demonstration board using the PIC18F452 microcontroller and TCP/IP firmware. The board supports any 40-pin DIP device that conforms to the standard pinout used by the PIC16F877 or PIC18C452. This kit features a user friendly TCP/IP stack, web server with HTML, a 24L256 Serial EEPROM for Xmodem download to web pages into Serial EEPROM, ICSP/MPLAB ICD 2 interface connector, an Ethernet interface, RS-232 interface, and a 16 x 2 LCD display. Also included is the book and CD-ROM *"TCP/IP Lean, Web Servers for Embedded Systems,"* by Jeremy Bentham

12.16 PICDEM 2 Plus Demonstration Board

The PICDEM 2 Plus demonstration board supports many 18-, 28-, and 40-pin microcontrollers, including PIC16F87X and PIC18FXX2 devices. All the necessary hardware and software is included to run the demonstration programs. The sample microcontrollers provided with the PICDEM 2 demonstration board can be programmed with a PRO MATE II device programmer, PICSTART Plus development programmer, or MPLAB ICD 2 with a Universal Programmer Adapter. The MPLAB ICD 2 and MPLAB ICE in-circuit emulators may also be used with the PICDEM 2 demonstration board to test firmware. A prototype area extends the circuitry for additional application components. Some of the features include an RS-232 interface, a 2 x 16 LCD display, a piezo speaker, an on-board temperature sensor, four LEDs, and sample PIC18F452 and PIC16F877 FLASH microcontrollers.

12.17 PICDEM 3 PIC16C92X Demonstration Board

The PICDEM 3 demonstration board supports the PIC16C923 and PIC16C924 in the PLCC package. All the necessary hardware and software is included to run the demonstration programs.

12.18 PICDEM 4 8/14/18-Pin Demonstration Board

The PICDEM 4 can be used to demonstrate the capabilities of the 8-, 14-, and 18-pin PIC16XXXX and PIC18XXXX MCUs, including the PIC16F818/819, PIC16F87/88, PIC16F62XA and the PIC18F1320 Family of microcontrollers. PICDEM 4 is intended to showcase the many features of these low pin count parts, including LIN and Motor Control using ECCP. Special provisions are made for low power operation with the supercapacitor circuit, and jumpers allow on-board hardware to be disabled to eliminate current draw in this mode. Included on the demo board are provisions for Crystal, RC or Canned Oscillator modes, a five volt regulator for use with a nine volt wall adapter or battery, DB-9 RS-232 interface, ICD connector for programming via ICSP and development with MPLAB ICD 2, 2x16 liquid crystal display, PCB footprints for H-Bridge motor driver, LIN transceiver and EEPROM. Also included are: header for expansion, eight LEDs, four potentiometers, three push buttons and a prototyping area. Included with the kit is a PIC16F627A and a PIC18F1320. Tutorial firmware is included along with the User's Guide.

12.19 PICDEM 17 Demonstration Board

The PICDEM 17 demonstration board is an evaluation board that demonstrates the capabilities of several Microchip microcontrollers, including PIC17C752, PIC17C756A, PIC17C762 and PIC17C766. A programmed sample is included. The PRO MATE II device programmer, or the PICSTART Plus development programmer, can be used to reprogram the device for user tailored application development. The PICDEM 17 demonstration board supports program download and execution from external on-board FLASH memory. A generous prototype area is available for user hardware expansion.

12.20 PICDEM 18R PIC18C601/801 Demonstration Board

The PICDEM 18R demonstration board serves to assist development of the PIC18C601/801 family of Microchip microcontrollers. It provides hardware implementation of both 8-bit Multiplexed/De-multiplexed and 16-bit Memory modes. The board includes 2 Mb external FLASH memory and 128 Kb SRAM memory, as well as serial EEPROM, allowing access to the wide range of memory types supported by the PIC18C601/801.

12.21 PICDEM LIN PIC16C43X Demonstration Board

The powerful LIN hardware and software kit includes a series of boards and three PIC microcontrollers. The small footprint PIC16C432 and PIC16C433 are used as slaves in the LIN communication and feature on-board LIN transceivers. A PIC16F874 FLASH microcontroller serves as the master. All three microcontrollers are programmed with firmware to provide LIN bus communication.

12.22 PICKit™ 1 FLASH Starter Kit

A complete "development system in a box", the PICKit FLASH Starter Kit includes a convenient multi-section board for programming, evaluation, and development of 8/14-pin FLASH PIC® microcontrollers. Powered via USB, the board operates under a simple Windows GUI. The PICKit 1 Starter Kit includes the user's guide (on CD ROM), PICKit 1 tutorial software and code for various applications. Also included are MPLAB® IDE (Integrated Development Environment) software, software and hardware "Tips 'n Tricks for 8-pin FLASH PIC® Microcontrollers" Handbook and a USB Interface Cable. Supports all current 8/14-pin FLASH PIC microcontrollers, as well as many future planned devices.

12.23 PICDEM USB PIC16C7X5 Demonstration Board

The PICDEM USB Demonstration Board shows off the capabilities of the PIC16C745 and PIC16C765 USB microcontrollers. This board provides the basis for future USB products.

12.24 Evaluation and Programming Tools

In addition to the PICDEM series of circuits, Microchip has a line of evaluation kits and demonstration software for these products.

- KEELOQ evaluation and programming tools for Microchip's HCS Secure Data Products
- CAN developers kit for automotive network applications
- Analog design boards and filter design software
- PowerSmart battery charging evaluation/calibration kits
- IrDA® development kit
- microID development and rLab™ development software
- SEEVAL® designer kit for memory evaluation and endurance calculations
- PICDEM MSC demo boards for Switching mode power supply, high power IR driver, delta sigma ADC, and flow rate sensor

Check the Microchip web page and the latest Product Line Card for the complete list of demonstration and evaluation kits.

rfPIC12F675

NOTES:

13.0 ELECTRICAL SPECIFICATIONS

Absolute Maximum Ratings†

Ambient temperature under bias	-40 to +125°C
Storage temperature	-65°C to +150°C
Voltage on VDD with respect to VSS	-0.3 to +6.5V
Voltage on VDDRF with respect to VSSRF	-0.3 to +7.0V
Voltage on $\overline{\text{MCLR}}$ with respect to VSS	-0.3 to +13.5V
Voltage on all GPIO pins with respect to VSS	-0.3V to (VDD + 0.3V)
Voltage on all other RF Transmitter pins with respect to VSSRF	-0.3V to (VDDRF + 0.3V)
Total power dissipation ⁽¹⁾	800 mW
Maximum current out of VSS pin	300 mA
Maximum current into VDD pin	250 mA
Input clamp current, I _{IK} (V _I < 0 or V _I > VDD)	± 20 mA
Output clamp current, I _{OK} (V _O < 0 or V _O > VDD)	± 20 mA
Maximum output current sunk by any GPIO pin	25 mA
Maximum output current sourced by any GPIO pin	25 mA
Maximum total current sunk by all GPIO pins	125 mA
Maximum total current sourced all GPIO pins	125 mA

Note 1: Power dissipation is calculated as follows:

$$P_{DIS} = VDD \times \{I_{DD} - \sum I_{OH}\} + \sum \{(VDD - V_{OH}) \times I_{OH}\} + \sum (V_{OL} \times I_{OL}) + VDDRF \times \{I_{DDRF} - \sum I_{OHRF}\} + \sum \{(VDDRF - V_{OHRF}) \times I_{OHRF}\} + \sum (V_{OLRF} \times I_{OLRF})$$

† **NOTICE:** Stresses above those listed under 'Absolute Maximum Ratings' may cause permanent damage to the device. This is a stress rating only and functional operation of the device at those or any other conditions above those indicated in the operation listings of this specification is not implied. Exposure to maximum rating conditions for extended periods may affect device reliability.

Note: Voltage spikes below VSS at the $\overline{\text{MCLR}}$ pin, inducing currents greater than 80 mA, may cause latchup. Thus, a series resistor of 50-100 Ω should be used when applying a "low" level to the $\overline{\text{MCLR}}$ pin, rather than pulling this pin directly to VSS.

rfPIC12F675

FIGURE 13-1: rfPIC12F675 WITH A/D DISABLED VOLTAGE-FREQUENCY GRAPH, $-40^{\circ}\text{C} \leq T_A \leq +125^{\circ}\text{C}$

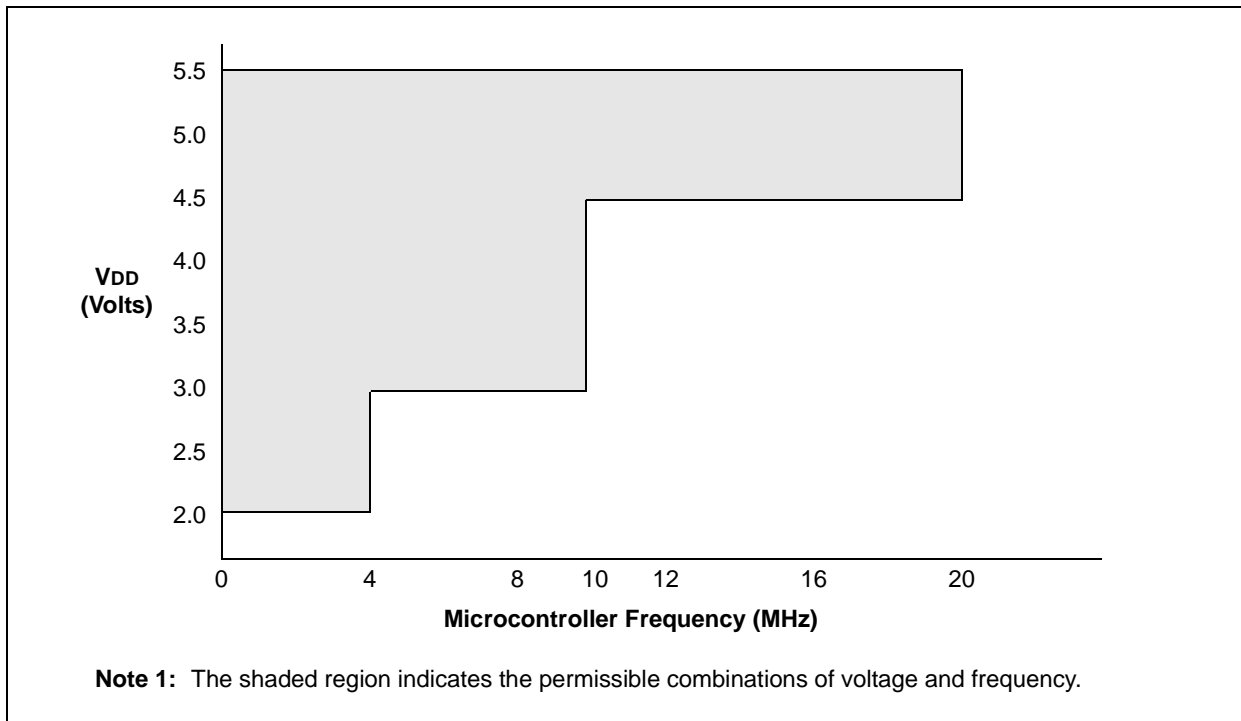

FIGURE 13-2: rfPIC12F675 WITH A/D ENABLED VOLTAGE-FREQUENCY GRAPH, $-40^{\circ}\text{C} \leq T_A \leq +125^{\circ}\text{C}$

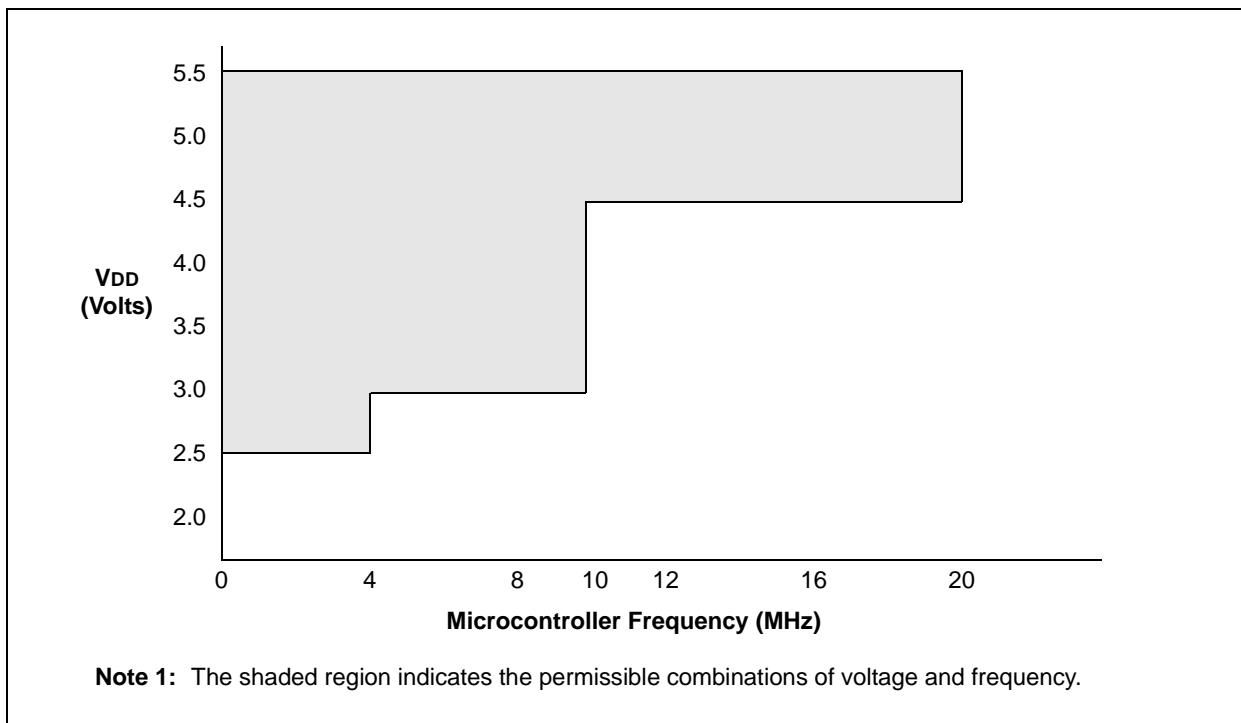
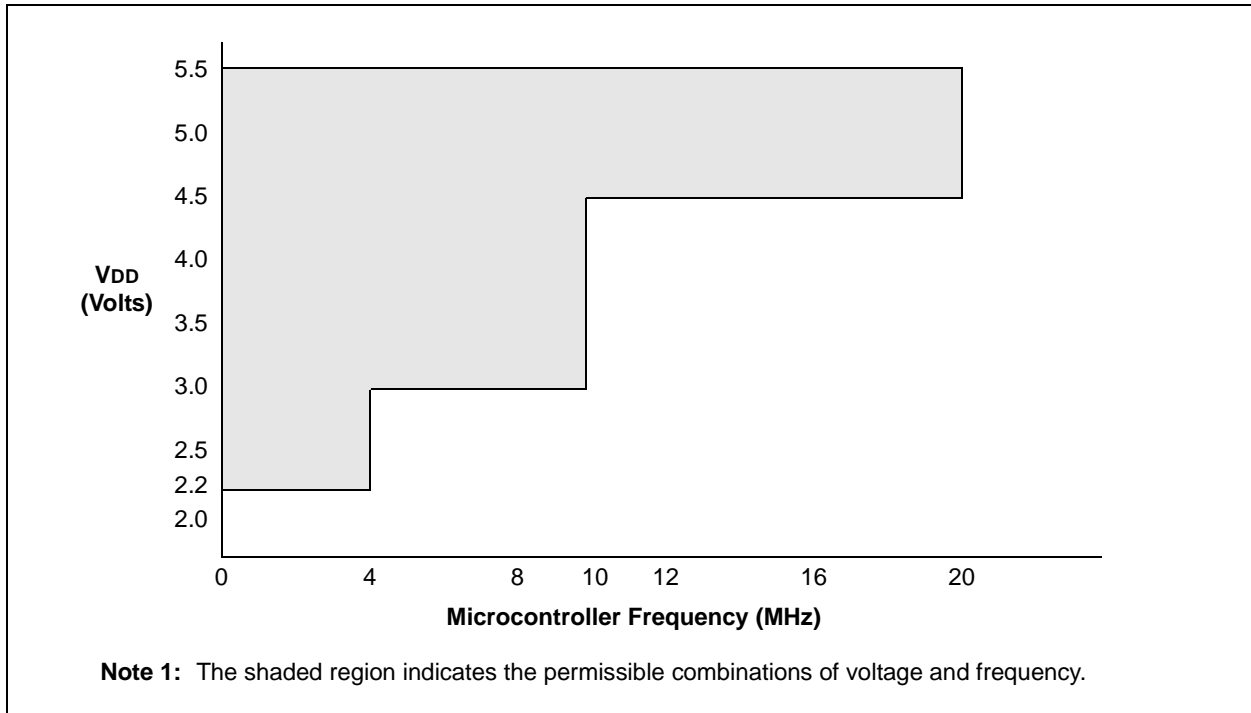

FIGURE 13-3: rfPIC12F675 WITH A/D ENABLED VOLTAGE-FREQUENCY GRAPH, $0^{\circ}\text{C} \leq T_A \leq +125^{\circ}\text{C}$



rfPIC12F675

13.1 DC Characteristics: rfPIC12F675-I (Industrial), rfPIC12F675-E (Extended)

DC CHARACTERISTICS			Standard Operating Conditions (unless otherwise stated) Operating temperature $-40^{\circ}\text{C} \leq T_A \leq +85^{\circ}\text{C}$ for industrial $-40^{\circ}\text{C} \leq T_A \leq +125^{\circ}\text{C}$ for extended				
Param No.	Sym	Characteristic	Min	Typ†	Max	Units	Conditions
D001 D001A D001B D001C D001D	VDD	Supply Voltage	2.0 2.2 2.5 3.0 4.5	— — — — —	5.5 5.5 5.5 5.5 5.5	V V V V V	Fosc \leq 4 MHz: rfPIC12F675 with A/D off rfPIC12F675 with A/D on, 0°C to $+125^{\circ}\text{C}$ rfPIC12F675 with A/D on, -40°C to $+125^{\circ}\text{C}$ 4 MHz < Fosc \leq 10 MHz Fosc > 10 MHz
D002	VDR	RAM Data Retention Voltage⁽¹⁾	1.5*	—	—	V	Device in SLEEP mode
D003	VPOR	VDD Start Voltage to ensure internal Power-on Reset signal	—	VSS	—	V	See section on Power-on Reset for details
D004	SVDD	VDD Rise Rate to ensure internal Power-on Reset signal	0.05*	—	—	V/ms	See section on Power-on Reset for details
D005	VBOD		—	2.1	—	V	
D006 D006A D006B D006C	VDDRF	RF Transmitter Supply Voltage	2.0 3.0 4.0 5.0	— — — —	5.5 5.5 5.5 5.5	V V V V	Output Power = 4 dBm Output Power = 7.5 dBm Output Power = 8.5 dBm Output Power = 9 dBm
D007	VLVD	RF Low Voltage Disable	1.8	1.85	1.9	V	$T_A = +23^{\circ}\text{C}$, RFEN = VDDRF

* These parameters are characterized but not tested.

† Data in "Typ" column is at 5.0V, 25°C unless otherwise stated. These parameters are for design guidance only and are not tested.

Note 1: This is the limit to which VDD can be lowered in SLEEP mode without losing RAM data.

13.2 DC Characteristics: rfPIC12F675-I (Industrial)

		Standard Operating Conditions (unless otherwise stated)						
		Operating temperature $-40^{\circ}\text{C} \leq T_A \leq +85^{\circ}\text{C}$ for industrial						
Param No.	Device Characteristics	Min	Typ†	Max	Units	Conditions		
						VDD	Note	
D010	Supply Current (IDD) ⁽³⁾	—	9	16	μA	2.0	Fosc = 32 kHz LP Oscillator Mode	
		—	18	28	μA	3.0		
		—	34	54	μA	5.0		
D011		—	110	150	μA	2.0	Fosc = 1 MHz XT Oscillator Mode	
		—	190	280	μA	3.0		
		—	330	450	μA	5.0		
D012		—	220	280	μA	2.0	Fosc = 4 MHz XT Oscillator Mode	
		—	370	650	μA	3.0		
		—	0.6	1.4	mA	5.0		
D013		—	70	110	μA	2.0	Fosc = 1 MHz EC Oscillator Mode	
		—	140	250	μA	3.0		
		—	260	390	μA	5.0		
D014		—	180	250	μA	2.0	Fosc = 4 MHz EC Oscillator Mode	
		—	320	470	μA	3.0		
		—	580	850	μA	5.0		
D015		—	340	450	μA	2.0	Fosc = 4 MHz INTOSC Mode	
		—	500	700	μA	3.0		
		—	0.8	1.1	mA	5.0		
D016		—	180	250	μA	2.0	Fosc = 4 MHz EXTRC Mode	
		—	320	450	μA	3.0		
		—	580	800	μA	5.0		
D017		—	2.1	2.95	mA	4.5	Fosc = 20 MHz HS Oscillator Mode	
		—	2.4	3.0	mA	5.0		

† Data in 'Typ' column is at 5.0V, 25°C unless otherwise stated. These parameters are for design guidance only and are not tested.

- Note 1:** The test conditions for all IDD measurements in Active Operation mode are: OSC1 = external square wave, from rail to rail; all I/O pins tri-stated, pulled to VDD; MCLR = VDD; WDT disabled.
- 2:** The supply current is mainly a function of the operating voltage and frequency. Other factors such as I/O pin loading and switching rate, oscillator type, internal code execution pattern, and temperature also have an impact on the current consumption.
- 3:** Total device current is the sum of IDD from VDD and IDDRF from VDDRF.

rfPIC12F675

13.3 DC Characteristics: rfPIC12F675-I (Industrial)

		Standard Operating Conditions (unless otherwise stated)						
		Operating temperature $-40^{\circ}\text{C} \leq T_A \leq +85^{\circ}\text{C}$ for industrial						
Param No.	Device Characteristics	Min	Typ†	Max	Units	Conditions		
						VDD	Note	
D020	Power-down Current (IPD) ⁽³⁾	—	0.99	700	nA	2.0	WDT, BOD, Comparators, VREF, and T1OSC disabled	
		—	1.2	770	nA	3.0		
		—	2.9	995	nA	5.0		
D021		—	0.3	1.5	μA	2.0	WDT Current ⁽¹⁾	
		—	1.8	3.5	μA	3.0		
		—	8.4	17	μA	5.0		
D022		—	58	70	μA	3.0	BOD Current ⁽¹⁾	
		—	109	130	μA	5.0		
D023		—	3.3	6.5	μA	2.0	Comparator Current ⁽¹⁾	
		—	6.1	8.5	μA	3.0		
		—	11.5	16	μA	5.0		
D024		—	58	70	μA	2.0	CVREF Current ⁽¹⁾	
		—	85	100	μA	3.0		
		—	138	160	μA	5.0		
D025		—	4.0	6.5	μA	2.0	T1 Osc Current ⁽¹⁾	
		—	4.6	7.0	μA	3.0		
		—	6.0	10.5	μA	5.0		
D026		—	1.2	775	nA	3.0	A/D Current ⁽¹⁾	
		—	2.2	1.0	mA	5.0		
D027	Power-down RF Current (IPDRF) ⁽³⁾	—	0.050	TBD	μA	3.0	RF Transmitter with RFEN=0	

† Data in 'Typ' column is at 5.0V, 25°C unless otherwise stated. These parameters are for design guidance only and are not tested.

- Note 1:** The peripheral current is the sum of the base IDD or IPD and the additional current consumed when this peripheral is enabled. The peripheral Δ current can be determined by subtracting the base IDD or IPD current from this limit. Max values should be used when calculating total current consumption.
- 2:** The power-down current in SLEEP mode does not depend on the oscillator type. Power-down current is measured with the part in SLEEP mode, with all I/O pins in hi-impedance state and tied to VDD.
- 3:** Total device current is the sum of IPD from VDD and IPDRF from VDDRF.

13.4 DC Characteristics: rfPIC12F675-E (Extended)

		Standard Operating Conditions (unless otherwise stated)					Operating temperature $-40^{\circ}\text{C} \leq T_A \leq +125^{\circ}\text{C}$ for extended	
Param No.	Device Characteristics	Min	Typ†	Max	Units	Conditions		
						VDD	Note	
D010E	Supply Current (IDD) ⁽³⁾	—	9	16	μA	2.0	Fosc = 32 kHz LP Oscillator Mode	
		—	18	28	μA	3.0		
		—	35	54	μA	5.0		
D011E		—	110	150	μA	2.0	Fosc = 1 MHz XT Oscillator Mode	
		—	190	280	μA	3.0		
		—	330	450	μA	5.0		
D012E		—	220	280	μA	2.0	Fosc = 4 MHz XT Oscillator Mode	
		—	370	650	μA	3.0		
		—	0.6	1.4	mA	5.0		
D013E		—	70	110	μA	2.0	Fosc = 1 MHz EC Oscillator Mode	
		—	140	250	μA	3.0		
		—	260	390	μA	5.0		
D014E		—	180	250	μA	2.0	Fosc = 4 MHz EC Oscillator Mode	
		—	320	470	μA	3.0		
		—	580	850	μA	5.0		
D015E		—	340	450	μA	2.0	Fosc = 4 MHz INTOSC Mode	
		—	500	780	μA	3.0		
		—	0.8	1.1	mA	5.0		
D016E		—	180	250	μA	2.0	Fosc = 4 MHz EXTRC Mode	
		—	320	450	μA	3.0		
		—	580	800	μA	5.0		
D017E		—	2.1	2.95	mA	4.5	Fosc = 20 MHz HS Oscillator Mode	
		—	2.4	3.0	mA	5.0		

† Data in 'Typ' column is at 5.0V, 25°C unless otherwise stated. These parameters are for design guidance only and are not tested.

- Note 1:** The test conditions for all IDD measurements in Active Operation mode are: OSC1 = external square wave, from rail to rail; all I/O pins tri-stated, pulled to VDD; MCLR = VDD; WDT disabled.
- 2:** The supply current is mainly a function of the operating voltage and frequency. Other factors such as I/O pin loading and switching rate, oscillator type, internal code execution pattern, and temperature also have an impact on the current consumption.
- 3:** Total device current is the sum of IDD from VDD and IDDRF from VDDRF.

rfPIC12F675

13.5 DC Characteristics: rfPIC12F675-E (Extended)

		Standard Operating Conditions (unless otherwise stated) Operating temperature $-40^{\circ}\text{C} \leq T_A \leq +125^{\circ}\text{C}$ for extended						
Param No.	Device Characteristics	Min	Typ†	Max	Units	Conditions		
						VDD	Note	
D020E	Power-down Current (IPD) ⁽³⁾	—	0.0011	3.5	μA	2.0	WDT, BOD, Comparators, VREF, and T1OSC disabled	
		—	0.0012	4.0	μA	3.0		
		—	0.0022	8.0	μA	5.0		
D021E		—	0.3	6.0	μA	2.0	WDT Current ⁽¹⁾	
		—	1.8	9.0	μA	3.0		
		—	8.4	20	μA	5.0		
D022E		—	58	70	μA	3.0	BOD Current ⁽¹⁾	
		—	109	130	μA	5.0		
D023E		—	3.3	10	μA	2.0	Comparator Current ⁽¹⁾	
		—	6.1	13	μA	3.0		
		—	11.5	24	μA	5.0		
D024E		—	58	70	μA	2.0	CVREF Current ⁽¹⁾	
		—	85	100	μA	3.0		
		—	138	165	μA	5.0		
D025E		—	4.0	10	μA	2.0	T1 Osc Current ⁽¹⁾	
		—	4.6	12	μA	3.0		
		—	6.0	20	μA	5.0		
D026E		—	0.0012	6.0	μA	3.0	A/D Current ⁽¹⁾	
		—	0.0022	8.5	μA	5.0		
D027E	Power-down RF Current (IPDRF) ⁽³⁾	—	0.050	TBD	μA	3.0	RF Transmitter, RFEN=VSSRF	

† Data in 'Typ' column is at 5.0V, 25°C unless otherwise stated. These parameters are for design guidance only and are not tested.

- Note 1:** The peripheral current is the sum of the base IDD or IPD and the additional current consumed when this peripheral is enabled. The peripheral Δ current can be determined by subtracting the base IDD or IPD current from this limit. Max values should be used when calculating total current consumption.
- 2:** The power-down current in SLEEP mode does not depend on the oscillator type. Power-down current is measured with the part in SLEEP mode, with all I/O pins in hi-impedance state and tied to VDD.
- 3:** Total device current is the sum of IPD from VDD and IPDRF from VDDRF.

13.6 DC Characteristics: rfPIC12F675K

		Standard Operating Conditions (unless otherwise stated)					
		Operating temperature		TA = +23°C			
		Operating Frequency		f _c = 315 MHz			
Param No.	Device Characteristics	Min	Typ	Max	Units	Conditions	
						VDD	Note
D018A	RF Transmitter Current (IDDRF) ⁽²⁾	2.0	2.7	5.0	mA	3.0	Power Step 0, RFEN=DATAASK=1
D018B		2.9	3.5	7.0	mA	3.0	Power Step 1, RFEN=DATAASK=1
D018C		3.2	4.7	7.9	mA	3.0	Power Step 2, RFEN=DATAASK=1
D018D		4.5	6.5	11	mA	3.0	Power Step 3, RFEN=DATAASK=1
D018E		7.0	10.7	16	mA	3.0	Power Step 4, RFEN=DATAASK=1

Note 1: The supply current is mainly a function of the operating voltage and frequency. Other factors such as output loading and temperature also have an impact on the current consumption.

2: Total device current is the sum of IDD from VDD and IDDRF from VDDRF.

13.7 DC Characteristics: rfPIC12F675F

		Standard Operating Conditions (unless otherwise stated)					
		Operating temperature		TA = +23°C			
		Operating Frequency		f _c = 434 MHz			
Param No.	Device Characteristics	Min	Typ	Max	Units	Conditions	
						VDD	Note
D018A	RF Transmitter Current (IDDRF) ⁽²⁾	2.0	2.7	5.0	mA	3.0	Power Step 0, RFEN=DATAASK=1
D018B		2.9	3.5	7.0	mA	3.0	Power Step 1, RFEN=DATAASK=1
D018C		3.2	4.7	7.9	mA	3.0	Power Step 2, RFEN=DATAASK=1
D018D		4.5	6.5	11	mA	3.0	Power Step 3, RFEN=DATAASK=1
D018E		7.0	10.7	16	mA	3.0	Power Step 4, RFEN=DATAASK=1

Note 1: The supply current is mainly a function of the operating voltage and frequency. Other factors such as output loading and temperature also have an impact on the current consumption.

2: Total device current is the sum of IDD from VDD and IDDRF from VDDRF.

13.8 DC Characteristics: rfPIC12F675H

		Standard Operating Conditions (unless otherwise stated)					
		Operating temperature		TA = +23°C			
		Operating Frequency		f _c = 868 MHz			
Param No.	Device Characteristics	Min	Typ	Max	Units	Conditions	
						VDD	Note
D018A	RF Transmitter Current (IDDRF) ⁽²⁾	2.6	4.0	6.5	mA	3.0	Power Step 0, RFEN=DATAASK=1
D018B		3.5	5.3	8.5	mA	3.0	Power Step 1, RFEN=DATAASK=1
D018C		4.5	6.7	11	mA	3.0	Power Step 2, RFEN=DATAASK=1
D018D		6.0	9.0	14	mA	3.0	Power Step 3, RFEN=DATAASK=1
D018E		9.0	14.0	20	mA	3.0	Power Step 4, RFEN=DATAASK=1

Note 1: The supply current is mainly a function of the operating voltage and frequency. Other factors such as output loading and temperature also have an impact on the current consumption.

2: Total device current is the sum of IDD from VDD and IDDRF from VDDRF.

rfPIC12F675

13.9 DC Characteristics: rfPIC12F675-I (Industrial), rfPIC12F675-E (Extended)

DC CHARACTERISTICS			Standard Operating Conditions (unless otherwise stated)				
			Operating temperature -40°C ≤ TA ≤ +85°C for industrial -40°C ≤ TA ≤ +125°C for extended				
Param No.	Sym	Characteristic	Min	Typ†	Max	Units	Conditions
Input Low Voltage							
D030	V _{IL}	I/O ports	V _{SS}	—	0.8	V	4.5V ≤ V _{DD} ≤ 5.5V Otherwise Entire range (Note 1) (Note 1)
D030A		with TTL buffer	V _{SS}	—	0.15 V _{DD}	V	
D031		with Schmitt Trigger buffer	V _{SS}	—	0.2 V _{DD}	V	
D032		MCLR, OSC1 (RC mode)	V _{SS}	—	0.2 V _{DD}	V	
D033		OSC1 (XT and LP modes)	V _{SS}	—	0.3	V	
D033A		OSC1 (HS mode)	V _{SS}	—	0.3 V _{DD}	V	
D034		DATAASK, DATAFSK, RFEN	V _{SS}	—	0.3 V _{DDRF}	V	
Input High Voltage							
D040	V _{IH}	I/O ports	—	—	—	—	4.5V ≤ V _{DD} ≤ 5.5V otherwise entire range (Note 1) (Note 1)
D040A		with TTL buffer	2.0	—	V _{DD}	V	
D041		with Schmitt Trigger buffer	(0.25 V _{DD} +0.8)	—	V _{DD}	V	
D042		MCLR	0.8 V _{DD}	—	V _{DD}	V	
D043		OSC1 (XT and LP modes)	1.6	—	V _{DD}	V	
D043A		OSC1 (HS mode)	0.7 V _{DD}	—	V _{DD}	V	
D043B		OSC1 (RC mode)	0.9 V _{DD}	—	V _{DD}	V	
D044		DATAASK, DATAFSK, RFEN	0.7 V _{DD}	—	V _{DDRF}	V	
D070	IPUR	GPIO Weak Pull-up Current	50*	250	400*	μA	V _{DD} = 5.0V, V _{PIN} = V _{SS}
D071		DATAASK Weak Pull-up	0.1*	1.5	12*	μA	V _{DDRF} = RFEN = 3.0V
D072		RFENIN Weak Pull-down	0.2*	2.0	20*	μA	V _{DDRF} = RFEN = 3.0V
Input Leakage Current⁽³⁾							
D060	I _{IL}	GPIO ports, DATAASK, DATAFSK, RFEN	—	± 0.1	± 1	μA	V _{SS} ≤ V _{PIN} ≤ V _{DD} , Pin at hi-impedance V _{SS} ≤ V _{PIN} ≤ V _{DD} V _{SS} ≤ V _{PIN} ≤ V _{DD} V _{SS} ≤ V _{PIN} ≤ V _{DD} V _{SS} ≤ V _{PIN} ≤ V _{DD} , XT, HS and LP osc configuration
D060A		Analog inputs	—	± 0.1	± 1	μA	
D060B		V _{REF}	—	± 0.1	± 1	μA	
D061		MCLR ⁽²⁾	—	± 0.1	± 5	μA	
D063		OSC1	—	± 0.1	± 5	μA	
Output Low Voltage							
D080	V _{OL}	I/O ports	—	—	0.6	V	I _{OL} = 8.5 mA, V _{DD} = 4.5V (Ind.)
D083		OSC2/CLKOUT (RC mode)	—	—	0.6	V	I _{OL} = 1.6 mA, V _{DD} = 4.5V (Ind.) I _{OL} = 1.2 mA, V _{DD} = 4.5V (Ext.)
Output High Voltage							
D090	V _{OH}	I/O ports	V _{DD} - 0.7	—	—	V	I _{OH} = -3.0 mA, V _{DD} = 4.5V (Ind.)
D092		OSC2/CLKOUT (RC mode)	V _{DD} - 0.7	—	—	V	I _{OH} = -1.3 mA, V _{DD} = 4.5V (Ind.) I _{OH} = -1.0 mA, V _{DD} = 4.5V (Ext.)

* These parameters are characterized but not tested.

† Data in 'Typ' column is at 5.0V, 25°C unless otherwise stated. These parameters are for design guidance only and are not tested.

- Note 1:** In RC oscillator configuration, the OSC1/CLKIN pin is a Schmitt Trigger input. It is not recommended to use an external clock in RC mode.
- Note 2:** The leakage current on the MCLR pin is strongly dependent on the applied voltage level. The specified levels represent normal operating conditions. Higher leakage current may be measured at different input voltages.
- Note 3:** Negative current is defined as current sourced by the pin.

13.10 DC Characteristics: rfPIC12F675-I (Industrial), rfPIC12F675-E (Extended) (Cont.)

DC CHARACTERISTICS			Standard Operating Conditions (unless otherwise stated) Operating temperature $-40^{\circ}\text{C} \leq T_A \leq +85^{\circ}\text{C}$ for industrial $-40^{\circ}\text{C} \leq T_A \leq +125^{\circ}\text{C}$ for extended				
Param No.	Sym	Characteristic	Min	Typ†	Max	Units	Conditions
Capacitive Loading Specs on Output Pins							
D100	Cosc2	OSC2 pin	—	—	15*	pF	In XT, HS and LP modes when external clock is used to drive OSC1
D101	Cio	All I/O pins	—	—	50*	pF	
Data EEPROM Memory							
D120	ED	Byte Endurance	100K	1M	—	E/W	$-40^{\circ}\text{C} \leq T_A \leq +85^{\circ}\text{C}$
D120A	ED	Byte Endurance	10K	100K	—	E/W	$+85^{\circ}\text{C} \leq T_A \leq +125^{\circ}\text{C}$
D121	VDRW	VDD for Read/Write	V _{MIN}	—	5.5	V	Using EECON to read/write V _{MIN} = Minimum operating voltage
D122	TDEW	Erase/Write cycle time	—	5	6	ms	
D123	TRETD	Characteristic Retention	40	—	—	Year	Provided no other specifications are violated
D124	TREF	Number of Total Erase/Write Cycles before Refresh ⁽¹⁾	1M	10M	—	E/W	$-40^{\circ}\text{C} \leq T_A \leq +85^{\circ}\text{C}$
Program FLASH Memory							
D130	EP	Cell Endurance	10K	100K	—	E/W	$-40^{\circ}\text{C} \leq T_A \leq +85^{\circ}\text{C}$
D130A	ED	Cell Endurance	1K	10K	—	E/W	$+85^{\circ}\text{C} \leq T_A \leq +125^{\circ}\text{C}$
D131	VPR	VDD for Read	V _{MIN}	—	5.5	V	V _{MIN} = Minimum operating voltage
D132	VPEW	VDD for Erase/Write	4.5	—	5.5	V	
D133	TPEW	Erase/Write cycle time	—	2	2.5	ms	
D134	TRETD	Characteristic Retention	40	—	—	Year	Provided no other specifications are violated
RF Transmitter⁽²⁾							
D150	RON	FSK Switch On resistance	—	20	60	Ω	DATA _{FSK} =0, RFEN=1
D151	ROFF	FSK Switch Off resistance	1	—	—	M Ω	DATA _{FSK} =1, RFEN=1
D152A	VPS	RF Power Select Voltage	V _{SSRF}	—	0.1	V	Power Level Step 0
D152B			0.14	—	0.24	V	Power Level Step 1
D152C			0.28	—	0.51	V	Power Level Step 2
D152D			0.57	—	1.18	V	Power Level Step 3
D152E			1.23	—	V _{DDRF}	V	Power Level Step 4
D153			IPS	Power Select Current	6	8	11

* These parameters are characterized but not tested.

† Data in 'Typ' column is at 5.0V, 25°C unless otherwise stated. These parameters are for design guidance only and are not tested.

Note 1: See Section 8.5.1 for additional information.

2: These limits are tested at room temperature.

rfPIC12F675

13.11 TIMING PARAMETER SYMBOLOGY

The timing parameter symbols have been created with one of the following formats:

1. TppS2ppS
2. TppS

T			
F	Frequency	T	Time

Lowercase letters (pp) and their meanings:

pp			
cc	CCP1	osc	OSC1
ck	CLKOUT	rd	\overline{RD}
cs	\overline{CS}	rw	\overline{RD} or \overline{WR}
di	SDI	sc	SCK
do	SDO	ss	\overline{SS}
dt	Data in	t0	T0CKI
io	I/O port	t1	T1CKI
mc	\overline{MCLR}	wr	\overline{WR}

Uppercase letters and their meanings:

S			
F	Fall	P	Period
H	High	R	Rise
I	Invalid (Hi-impedance)	V	Valid
L	Low	Z	Hi-impedance

FIGURE 13-4: LOAD CONDITIONS

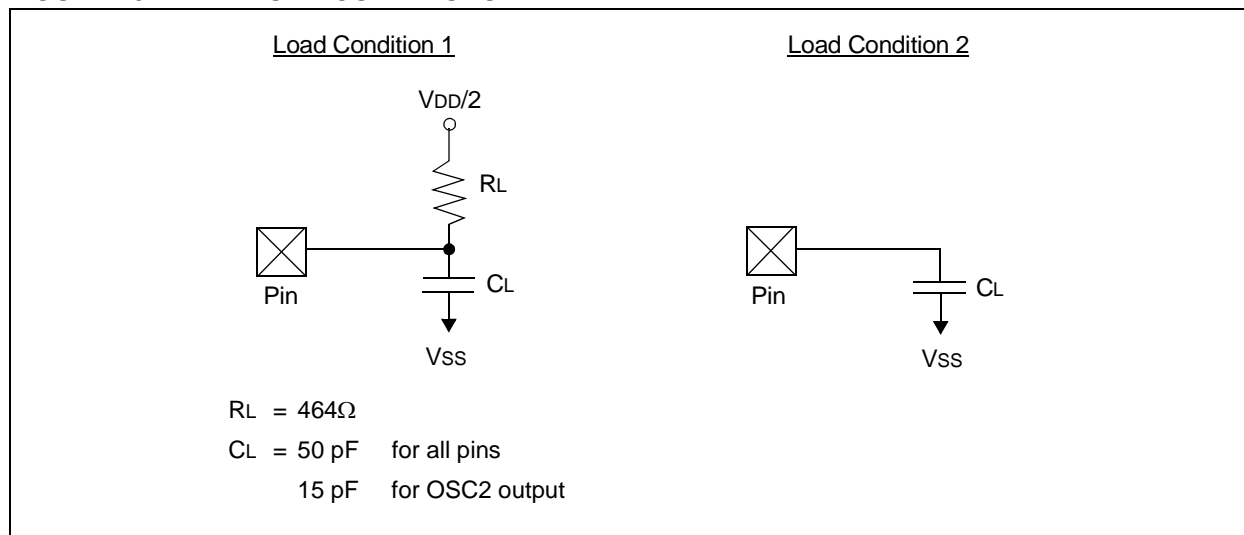

13.12 AC CHARACTERISTICS: rfPIC12F675 (INDUSTRIAL, EXTENDED)

FIGURE 13-5: EXTERNAL CLOCK TIMING

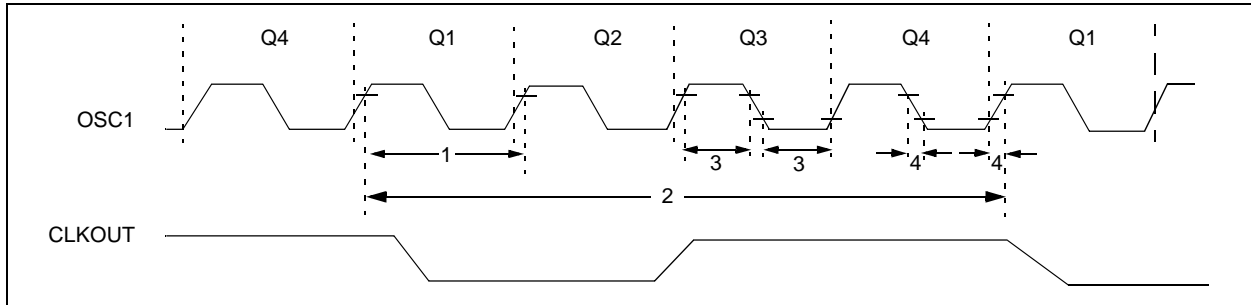

TABLE 13-1: EXTERNAL CLOCK TIMING REQUIREMENTS

Param No.	Sym	Characteristic	Min	Typ†	Max	Units	Conditions
	Fosc	External CLKIN Frequency ⁽¹⁾	DC	—	37	kHz	LP Osc mode
			DC	—	4	MHz	XT mode
			DC	—	20	MHz	HS mode
			DC	—	20	MHz	EC mode
	Oscillator Frequency ⁽¹⁾	5	—	37	kHz	LP Osc mode	
		—	4	—	MHz	INTOSC mode	
		DC	—	4	MHz	RC Osc mode	
		0.1	—	4	MHz	XT Osc mode	
1	Tosc	External CLKIN Period ⁽¹⁾	27	—	∞	μs	LP Osc mode
			50	—	∞	ns	HS Osc mode
			50	—	∞	ns	EC Osc mode
			250	—	∞	ns	XT Osc mode
	Oscillator Period ⁽¹⁾	27	—	200	μs	LP Osc mode	
—	250	—	—	ns	INTOSC mode		
250	—	—	—	ns	RC Osc mode		
250	—	10,000	ns	XT Osc mode			
50	—	1,000	ns	HS Osc mode			
2	Tcy	Instruction Cycle Time ⁽¹⁾	200	Tcy	DC	ns	Tcy = 4/Fosc
3	TosL, TosH	External CLKIN (OSC1) High External CLKIN Low	2*	—	—	μs	LP oscillator, TOSC L/H duty cycle
			20*	—	—	ns	HS oscillator, TOSC L/H duty cycle
			100*	—	—	ns	XT oscillator, TOSC L/H duty cycle
4	TosR, TosF	External CLKIN Rise External CLKIN Fall	—	—	50*	ns	LP oscillator
			—	—	25*	ns	XT oscillator
			—	—	15*	ns	HS oscillator

* These parameters are characterized but not tested.

† Data in 'Typ' column is at 5V, 25°C unless otherwise stated. These parameters are for design guidance only and are not tested.

Note 1: Instruction cycle period (Tcy) equals four times the input oscillator time-base period. All specified values are based on characterization data for that particular oscillator type under standard operating conditions with the device executing code. Exceeding these specified limits may result in an unstable oscillator operation and/or higher than expected current consumption. All devices are tested to operate at 'min' values with an external clock applied to OSC1 pin. When an external clock input is used, the 'max' cycle time limit is 'DC' (no clock) for all devices.

rfPIC12F675

TABLE 13-2: PRECISION INTERNAL OSCILLATOR PARAMETERS

Param No.	Sym	Characteristic	Freq Tolerance	Min	Typ†	Max	Units	Conditions
F10	Fosc	Internal Calibrated INTOSC Frequency	±1	3.96	4.00	4.04	MHz	VDD = 3.5V, 25°C
			±2	3.92	4.00	4.08	MHz	2.5V ≤ VDD ≤ 5.5V 0°C ≤ TA ≤ +85°C
			±5	3.80	4.00	4.20	MHz	2.0V ≤ VDD ≤ 5.5V -40°C ≤ TA ≤ +85°C (IND) -40°C ≤ TA ≤ +125°C (EXT)
F14	TOSC ST	Oscillator Wake-up from SLEEP start-up time*	—	—	6	8	μs	VDD = 2.0V, -40°C to +85°C
			—	—	4	6	μs	VDD = 3.0V, -40°C to +85°C
			—	—	3	5	μs	VDD = 5.0V, -40°C to +85°C

* These parameters are characterized but not tested.

† Data in 'Typ' column is at 5.0V, 25°C unless otherwise stated. These parameters are for design guidance only and are not tested.

FIGURE 13-6: CLKOUT AND I/O TIMING

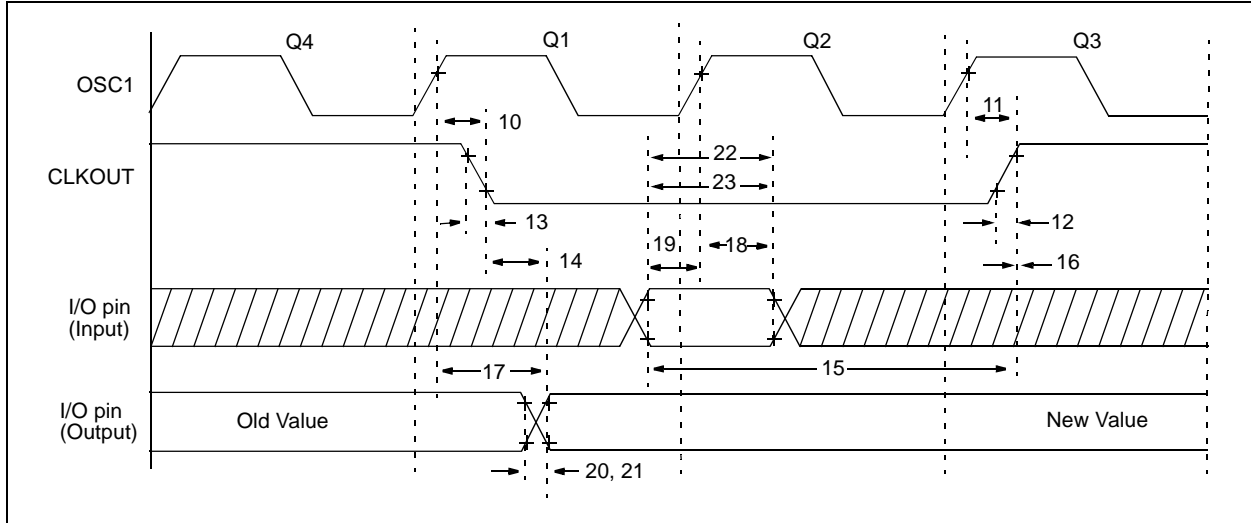

TABLE 13-3: CLKOUT AND I/O TIMING REQUIREMENTS

Param No.	Sym	Characteristic	Min	Typ†	Max	Units	Conditions
10	TosH2ckL	OSC1↑ to CLK-OUT↓	—	75	200	ns	(Note 1)
11	TosH2ckH	OSC1↑ to CLK-OUT↑	—	75	200	ns	(Note 1)
12	TckR	CLKOUT rise time	—	35	100	ns	(Note 1)
13	TckF	CLKOUT fall time	—	35	100	ns	(Note 1)
14	TckL2ioV	CLKOUT↓ to Port out valid	—	—	20	ns	(Note 1)
15	TioV2ckH	Port in valid before CLKOUT↑	Tosc + 200 ns	—	—	ns	(Note 1)
16	TckH2ioI	Port in hold after CLKOUT↑	0	—	—	ns	(Note 1)
17	TosH2ioV	OSC1↑ (Q1 cycle) to Port out valid	—	50	150 *	ns	
			—	—	300	ns	
18	TosH2ioI	OSC1↑ (Q2 cycle) to Port input invalid (I/O in hold time)	100	—	—	ns	
19	TioV2osH	Port input valid to OSC1↑ (I/O in setup time)	0	—	—	ns	
20	TioR	Port output rise time	—	10	40	ns	
21	TioF	Port output fall time	—	10	40	ns	
22	Tinp	INT pin high or low time	25	—	—	ns	
23	Trbp	GPIO change INT high or low time	TcY	—	—	ns	

* These parameters are characterized but not tested.

† Data in 'Typ' column is at 5.0V, 25°C unless otherwise stated.

Note 1: Measurements are taken in RC mode where CLKOUT output is 4xTosc.

rfPIC12F675

FIGURE 13-7: RESET, WATCHDOG TIMER, OSCILLATOR START-UP TIMER AND POWER-UP TIMER TIMING

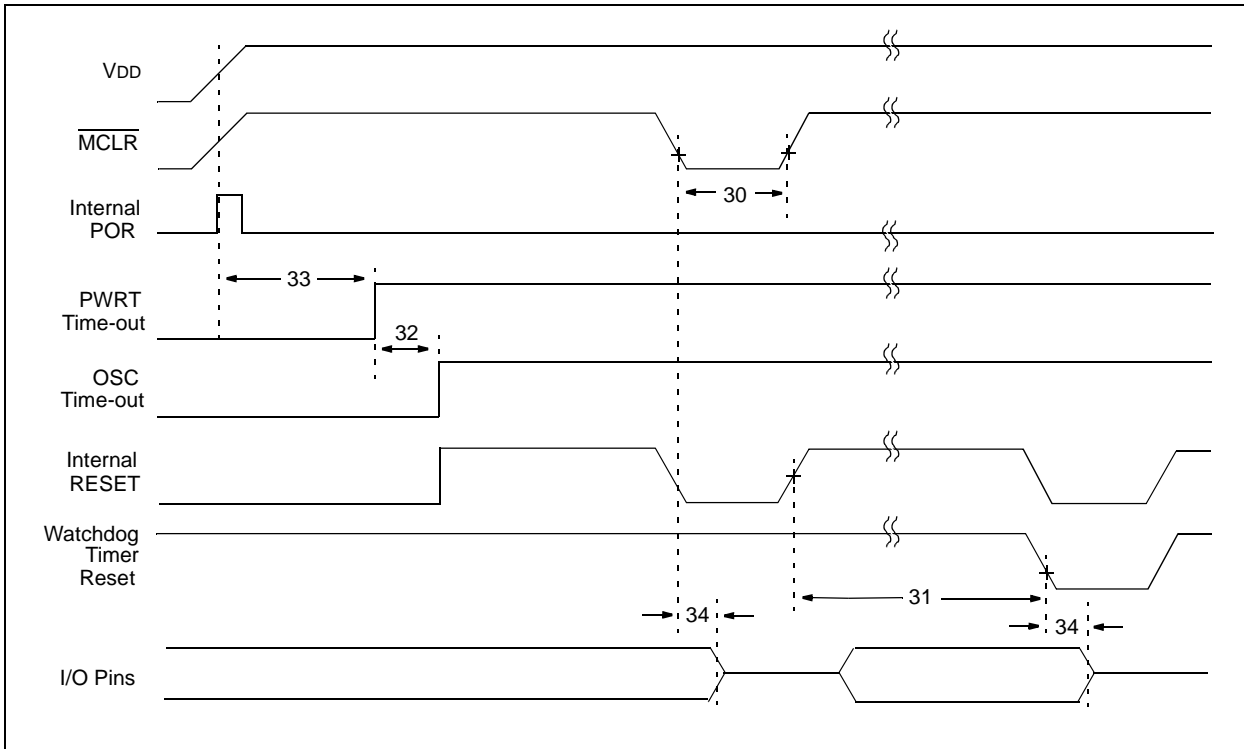

FIGURE 13-8: BROWN-OUT DETECT TIMING AND CHARACTERISTICS

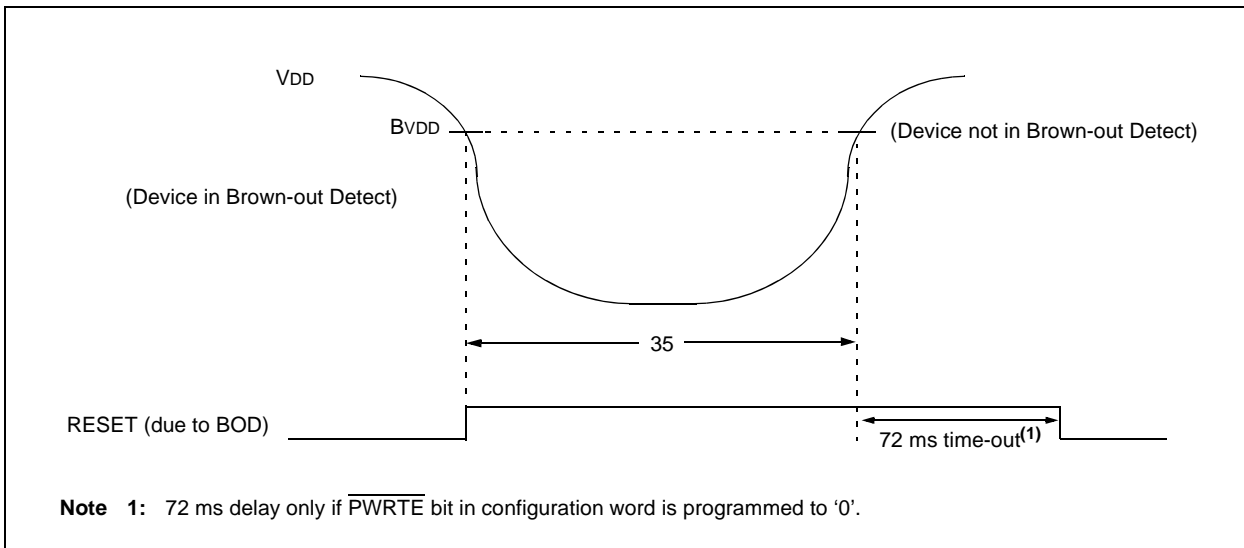

TABLE 13-4: RESET, WATCHDOG TIMER, OSCILLATOR START-UP TIMER, POWER-UP TIMER, AND BROWN-OUT DETECT REQUIREMENTS

Param No.	Sym	Characteristic	Min	Typ†	Max	Units	Conditions
30	TMCL	MCLR Pulse Width (low)	2 TBD	— TBD	— TBD	μs ms	VDD = 5V, -40°C to +85°C Extended temperature
31	TWDT	Watchdog Timer Time-out Period (No Prescaler)	10 10	17 17	25 30	ms ms	VDD = 5V, -40°C to +85°C Extended temperature
32	TOST	Oscillation Start-up Timer Period	—	1024Tosc	—	—	Tosc = OSC1 period
33*	TPWRT	Power-up Timer Period	28* TBD	72 TBD	132* TBD	ms ms	VDD = 5V, -40°C to +85°C Extended Temperature
34	TIOZ	I/O Hi-impedance from MCLR Low or Watchdog Timer Reset	—	—	2.0	μs	
	BVDD	Brown-out Detect Voltage	2.025	—	2.175	V	
		Brown-out Hysteresis	TBD	—	—	—	
35	TBOD	Brown-out Detect Pulse Width	100*	—	—	μs	VDD ≤ BVDD (D005)

* These parameters are characterized but not tested.

† Data in 'Typ' column is at 5V, 25°C unless otherwise stated. These parameters are for design guidance only and are not tested.

rfPIC12F675

FIGURE 13-9: TIMER0 AND TIMER1 EXTERNAL CLOCK TIMINGS

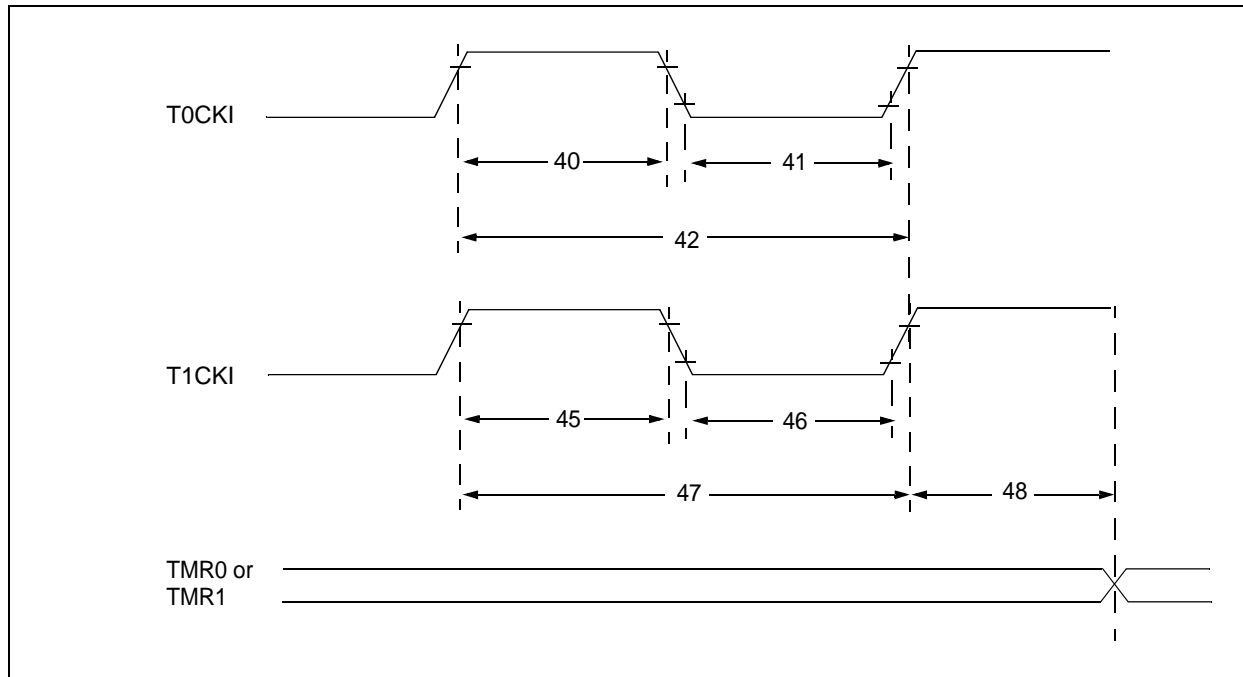

TABLE 13-5: TIMER0 AND TIMER1 EXTERNAL CLOCK REQUIREMENTS

Param No.	Sym	Characteristic		Min	Typ†	Max	Units	Conditions
40*	Tt0H	T0CKI High Pulse Width	No Prescaler	$0.5 T_{CY} + 20$	—	—	ns	
			With Prescaler	10	—	—	ns	
41*	Tt0L	T0CKI Low Pulse Width	No Prescaler	$0.5 T_{CY} + 20$	—	—	ns	
			With Prescaler	10	—	—	ns	
42*	Tt0P	T0CKI Period		Greater of: 20 or $\frac{T_{CY} + 40}{N}$	—	—	ns	N = prescale value (2, 4, ..., 256)
45*	Tt1H	T1CKI High Time	Synchronous, No Prescaler	$0.5 T_{CY} + 20$	—	—	ns	
			Synchronous, with Prescaler	15	—	—	ns	
			Asynchronous	30	—	—	ns	
46*	Tt1L	T1CKI Low Time	Synchronous, No Prescaler	$0.5 T_{CY} + 20$	—	—	ns	
			Synchronous, with Prescaler	15	—	—	ns	
			Asynchronous	30	—	—	ns	
47*	Tt1P	T1CKI Input Period	Synchronous	Greater of: 30 or $\frac{T_{CY} + 40}{N}$	—	—	ns	N = prescale value (1, 2, 4, 8)
			Asynchronous	60	—	—	ns	
	Ft1	Timer1 oscillator input frequency range (oscillator enabled by setting bit T1OSCEN)		DC	—	200*	kHz	
48	TCKEZtmr1	Delay from external clock edge to timer increment		$2 T_{osc}^*$	—	7 T_{osc}^*	—	

* These parameters are characterized but not tested.

† Data in 'Typ' column is at 5V, 25°C unless otherwise stated. These parameters are for design guidance only and are not tested.

TABLE 13-6: COMPARATOR SPECIFICATIONS

Comparator Specifications		Standard Operating Conditions -40°C to +125°C (unless otherwise stated)				
Sym	Characteristics	Min	Typ	Max	Units	Comments
VOS	Input Offset Voltage	—	± 5.0	± 10	mV	
VCM	Input Common Mode Voltage	0	—	VDD - 1.5	V	
CMRR	Common Mode Rejection Ratio	+55*	—	—	db	
TRT	Response Time ⁽¹⁾	—	150	400*	ns	
TMC2COV	Comparator Mode Change to Output Valid	—	—	10*	µs	

* These parameters are characterized but not tested.

Note 1: Response time measured with one comparator input at (VDD - 1.5)/2 while the other input transitions from VSS to VDD - 1.5V.

TABLE 13-7: COMPARATOR VOLTAGE REFERENCE SPECIFICATIONS

Voltage Reference Specifications		Standard Operating Conditions -40°C to +125°C (unless otherwise stated)				
Sym	Characteristics	Min	Typ	Max	Units	Comments
	Resolution	—	VDD/24*	—	LSb	Low Range (VRR = 1)
		—	VDD/32	—	LSb	High Range (VRR = 0)
	Absolute Accuracy	—	—	± 1/2	LSb	Low Range (VRR = 1)
		—	—	± 1/2*	LSb	High Range (VRR = 0)
	Unit Resistor Value (R)	—	2k*	—	Ω	
	Settling Time ⁽¹⁾	—	—	10*	µs	

* These parameters are characterized but not tested.

Note 1: Settling time measured while VRR = 1 and VR<3:0> transitions from 0000 to 1111.

rfPIC12F675

TABLE 13-8: rfPIC12F675 A/D CONVERTER CHARACTERISTICS:

Param No.	Sym	Characteristic	Min	Typ†	Max	Units	Conditions
A01	NR	Resolution	—	—	10 bits	bit	
A02	EABS	Total Absolute Error*	—	—	±1	LSb	VREF = 5.0V
A03	EIL	Integral Error	—	—	±1	LSb	VREF = 5.0V
A04	EDL	Differential Error	—	—	±1	LSb	No missing codes to 10 bits VREF = 5.0V
A05	EFS	Full Scale Range	2.2*	—	5.5*	V	
A06	E0FF	Offset Error	—	—	±1	LSb	VREF = 5.0V
A07	EGN	Gain Error	—	—	±1	LSb	VREF = 5.0V
A10	—	Monotonicity	—	guaranteed ⁽³⁾	—	—	VSS ≤ VAIN ≤ VREF+
A20 A20A	VREF	Reference Voltage	2.0 2.5	—	— VDD + 0.3	V	Absolute minimum to ensure 10-bit accuracy
A21	VREF	Reference V High (VDD or VREF)	VSS	—	VDD	V	
A25	VAIN	Analog Input Voltage	VSS	—	VREF	V	
A30	ZAIN	Recommended Impedance of Analog Voltage Source	—	—	10	kΩ	
A50	IREF	VREF Input Current ⁽²⁾	10 —	— —	1000 10	μA μA	During VAIN acquisition. Based on differential of VHOLD to VAIN. During A/D conversion cycle.

* These parameters are characterized but not tested.

† Data in 'Typ' column is at 5.0V, 25°C unless otherwise stated. These parameters are for design guidance only and are not tested.

Note 1: When A/D is off, it will not consume any current other than leakage current. The power-down current spec includes any such leakage from the A/D module.

2: VREF current is from External VREF or VDD pin, whichever is selected as reference input.

3: The A/D conversion result never decreases with an increase in the input voltage and has no missing codes.

FIGURE 13-10: rfPIC12F675 A/D CONVERSION TIMING (NORMAL MODE)

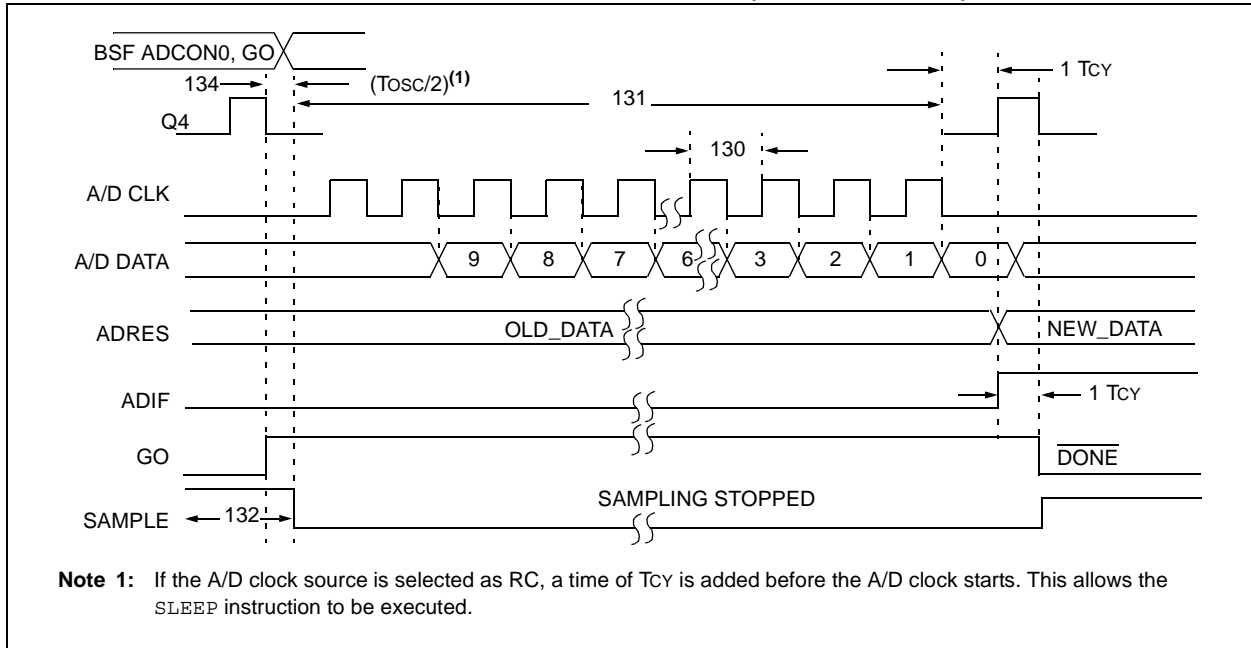

TABLE 13-9: rfPIC12F675 A/D CONVERSION REQUIREMENTS

Param No.	Sym	Characteristic	Min	Typ†	Max	Units	Conditions
130	TAD	A/D Clock Period	1.6	—	—	μs	TOSC based, $V_{REF} \geq 3.0\text{V}$
130	TAD	A/D Internal RC Oscillator Period	3.0*	—	—	μs	TOSC based, V_{REF} full range
			3.0*	6.0	9.0*	μs	ADCS<1:0> = 11 (RC mode) At $V_{DD} = 2.5\text{V}$
			2.0*	4.0	6.0*	μs	At $V_{DD} = 5.0\text{V}$
131	TCNV	Conversion Time (not including Acquisition Time) ⁽¹⁾	—	11	—	TAD	Set GO bit to new data in A/D result register
132	TACQ	Acquisition Time	(Note 2)	11.5	—	μs	The minimum time is the amplifier settling time. This may be used if the "new" input voltage has not changed by more than 1 LSB (i.e., 4.1 mV @ 4.096V) from the last sampled voltage (as stored on CHOLD).
			5*	—	—	μs	
134	TGO	Q4 to A/D Clock Start	—	Tosc/2	—	—	If the A/D clock source is selected as RC, a time of T_{CY} is added before the A/D clock starts. This allows the SLEEP instruction to be executed.

* These parameters are characterized but not tested.

† Data in 'Typ' column is at 5.0V, 25°C unless otherwise stated. These parameters are for design guidance only and are not tested.

Note 1: ADRES register may be read on the following T_{CY} cycle.

Note 2: See Section 7.1 for minimum conditions.

rfPIC12F675

FIGURE 13-11: rfPIC12F675 A/D CONVERSION TIMING (SLEEP MODE)

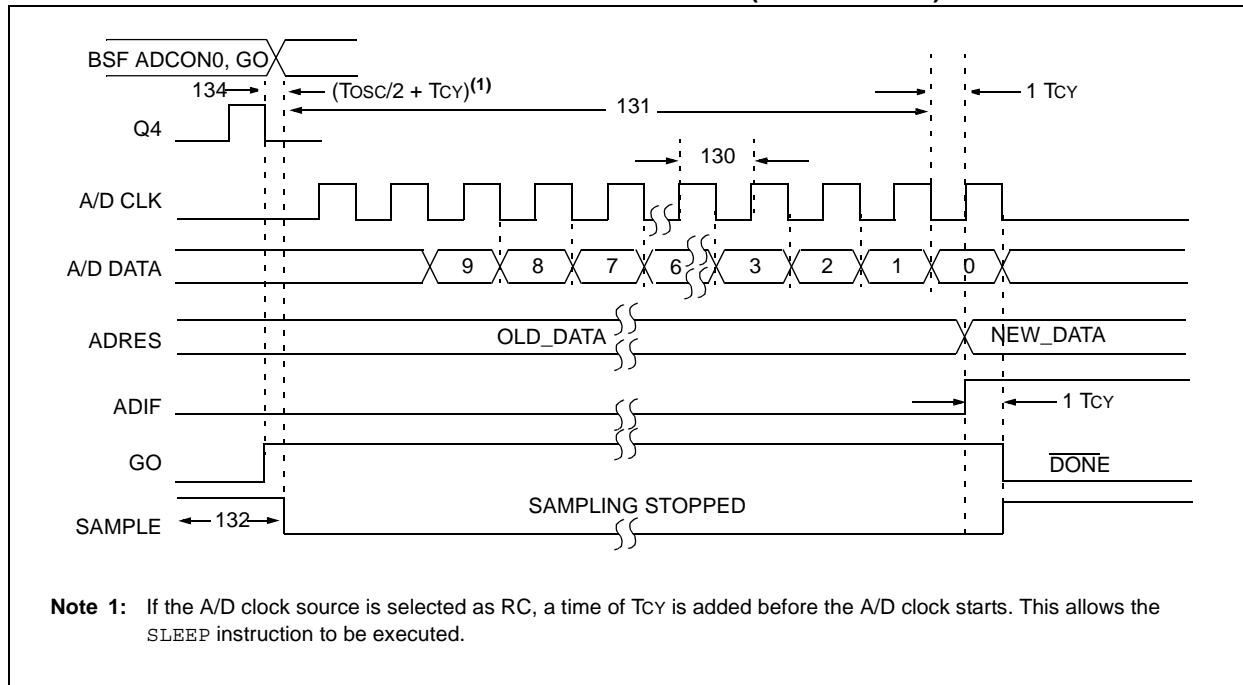

TABLE 13-10: rfPIC12F675 A/D CONVERSION REQUIREMENTS (SLEEP MODE)

Param No.	Sym	Characteristic	Min	Typ†	Max	Units	Conditions
130	TAD	A/D Clock Period	1.6	—	—	μs	$V_{REF} \geq 3.0\text{V}$
130	TAD	A/D Internal RC Oscillator Period	3.0*	—	—	μs	V_{REF} full range
			3.0*	6.0	9.0*	μs	ADCS<1:0> = 11 (RC mode)
			2.0*	4.0	6.0*	μs	At $V_{DD} = 2.5\text{V}$
							At $V_{DD} = 5.0\text{V}$
131	T _{CV}	Conversion Time (not including Acquisition Time) ⁽¹⁾	—	11	—	TAD	
132	T _{ACQ}	Acquisition Time	(Note 2)	11.5	—	μs	The minimum time is the amplifier settling time. This may be used if the “new” input voltage has not changed by more than 1 LSb (i.e., 4.1 mV @ 4.096V) from the last sampled voltage (as stored on CHOLD).
			5*	—	—	μs	
134	T _{GO}	Q4 to A/D Clock Start	—	$T_{OSC}/2 + T_{CY}$	—	—	If the A/D clock source is selected as RC, a time of T_{CY} is added before the A/D clock starts. This allows the <code>SLEEP</code> instruction to be executed.

* These parameters are characterized but not tested.

† Data in ‘Typ’ column is at 5.0V, 25°C unless otherwise stated. These parameters are for design guidance only and are not tested.

Note 1: ADRES register may be read on the following T_{CY} cycle.

Note 2: See Section 7.1 for minimum conditions.

TABLE 13-11: rfPIC12F675K RF TRANSMITTER SPECIFICATIONS (315 MHz)

RF Transmitter Specifications		Standard Operating Conditions TA = +23°C (unless otherwise stated) VDDRF = 3.0V (unless otherwise stated) FC = 315 MHz (unless otherwise stated)				
Sym	Characteristics	Min	Typ	Max	Units	Comments
FC	VCO Frequency	290	—	350	MHz	32 x FRFXTAL
FXTAL	Crystal Frequency	9.06	—	10.94	MHz	Fundamental mode
FREF	Reference Frequency	2.265	—	2.735	MHz	FRFXTAL / 4
CL	Load Capacitance	10	—	15	pF	
CO	Static Capacitance	—	—	7	pF	
RS	Series Resistance	—	—	70	Ω	
ASPUR	Spurious response	—	—	-10	dB	For FSK operation
ΔFVDD	Frequency Stability vs VDDRF	—	—	±3	ppm	
ΔFTA	Frequency Stability vs Temp	—	—	±10	ppm	Crystal temp constant
ΔF	FSK Deviation	±5	—	±80	kHz	Depends on crystal parameters
RFSK	FSK Data Rate	—	—	40	Kbit/s	NRZ
RASK	ASK Data Rate	—	—	40	Kbit/s	NRZ
TON	RFEN High to Transmit	—	1.2	1.5	ms	
POFF	RF Output Power in Step 0	—	—	-70	dBm	RFEN=1
P1	RF Output Power in Step 1	—	-12	—	dBm	RFEN=1
P2	RF Output Power in Step 2	—	-4	—	dBm	RFEN=1
P3	RF Output Power in Step 3	—	2	—	dBm	RFEN=1
P4	RF Output Power in Step 4	—	4	—	dBm	RFEN=1, VDDRF=2.0V
		—	7.5	—	dBm	RFEN=1, VDDRF=3.0V
		—	8.5	9.5	dBm	RFEN=1, VDDRF=4.0V
		—	9.0	10.5	dBm	RFEN=1, VDDRF=5.0V
L(FM)	Phase Noise	—	-86	—	dBc/Hz	200 kHz offset
PSPUR	Spurious Emissions	—	—	-54	dBm	47 MHz < f < 74 MHz 87.5 MHz < f < 118 MHz 174 MHz < f < 230 MHz 470 MHz < f < 862 MHz RBW = 100 kHz
		—	—	-36	dBm	f < 1 GHz RBW = 100 kHz
		—	—	-30	dBm	f > 1 GHz RBW = 1 MHz

rfPIC12F675

TABLE 13-12: rfPIC12F675F RF TRANSMITTER SPECIFICATIONS (434 MHz)

RF Transmitter Specifications		Standard Operating Conditions TA = +23°C (unless otherwise stated) VDDRF = 3.0V (unless otherwise stated) FC = 433.92 MHz (unless otherwise stated)				
Sym	Characteristics	Min	Typ	Max	Units	Comments
FC	VCO Frequency	380	—	450	MHz	32 x FRFXTAL
FXTAL	Crystal Frequency	11.88	—	14.06	MHz	Fundamental mode
FREF	Reference Frequency	2.97	—	3.515	MHz	FRFXTAL / 4
CL	Load Capacitance	10	—	15	pF	
CO	Static Capacitance	—	—	7	pF	
RS	Series Resistance	—	—	70	Ω	
ASPUR	Spurious response	—	—	-10	dB	For FSK operation
ΔFVDD	Frequency Stability vs VDDRF	—	—	±3	ppm	
ΔFTA	Frequency Stability vs Temp	—	—	±10	ppm	Crystal temp constant
ΔF	FSK Deviation	±5	—	±80	kHz	Depends on crystal parameters
RFSK	FSK Data Rate	—	—	40	Kbit/s	NRZ
RASK	ASK Data Rate	—	—	40	Kbit/s	NRZ
TON	RFEN High to Transmit	—	0.8	1.2	ms	
POFF	RF Output Power in Step 0	—	—	-70	dBm	RFEN=1
P1	RF Output Power in Step 1	—	-12	—	dBm	RFEN=1
P2	RF Output Power in Step 2	—	-4	—	dBm	RFEN=1
P3	RF Output Power in Step 3	—	2	—	dBm	RFEN=1
P4	RF Output Power in Step 4	—	4	—	dBm	RFEN=1, VDDRF=2.0V
		—	7.5	—	dBm	RFEN=1, VDDRF=3.0V
		—	8.5	9.5	dBm	RFEN=1, VDDRF=4.0V
		—	9.0	10.5	dBm	RFEN=1, VDDRF=5.0V
L(FM)	Phase Noise	—	-86	—	dBc/Hz	200 kHz offset
PSPUR	Spurious Emissions	—	—	-54	dBm	47 MHz < f < 74 MHz 87.5 MHz < f < 118 MHz 174 MHz < f < 230 MHz 470 MHz < f < 862 MHz RBW = 100 kHz
		—	—	-36	dBm	f < 1 GHz RBW = 100 kHz
		—	—	-30	dBm	f > 1 GHz RBW = 1 MHz

TABLE 13-13: rfPIC12F675H RF TRANSMITTER SPECIFICATIONS (868/915 MHz)

RF Transmitter Specifications		Standard Operating Conditions				
		TA = +23°C (unless otherwise stated) VDDRF = 3.0V (unless otherwise stated) FC = 868.3 MHz (unless otherwise stated)				
Sym	Characteristics	Min	Typ	Max	Units	Comments
FC	VCO Frequency	850	—	930	MHz	32 x FRFXTAL
FXTAL	Crystal Frequency	26.56	—	29.06	MHz	Fundamental mode
FREF	Reference Frequency	3.32	—	3.63	MHz	FRFXTAL / 8
CL	Load Capacitance	10	—	15	pF	
CO	Static Capacitance	—	—	7	pF	
RS	Series Resistance	—	—	50	Ω	
ASPUR	Spurious response	—	—	-10	dB	For FSK operation
ΔFVDD	Frequency Stability vs VDDRF	—	—	±3	ppm	
ΔFTA	Frequency Stability vs Temp	—	—	±10	ppm	Crystal temp constant
ΔF	FSK Deviation	±5	—	±80	kHz	Depends on crystal parameters
RFSK	FSK Data Rate	—	—	40	Kbit/s	NRZ
RASK	ASK Data Rate	—	—	40	Kbit/s	NRZ
TON	RFEN High to Transmit	—	0.6	1.0	ms	
POFF	RF Output Power in Step 0	—	—	-70	dBm	RFEN=1
P1	RF Output Power in Step 1	—	-12	—	dBm	RFEN=1
P2	RF Output Power in Step 2	—	-4	—	dBm	RFEN=1
P3	RF Output Power in Step 3	—	2	—	dBm	RFEN=1
P4	RF Output Power in Step 4	—	4	—	dBm	RFEN=1, VDDRF=2.0V
		—	7.5	—	dBm	RFEN=1, VDDRF=3.0V
		—	8.5	9.5	dBm	RFEN=1, VDDRF=4.0V
		—	9.0	10.5	dBm	RFEN=1, VDDRF=5.0V
L(FM)	Phase Noise	—	-82	—	dBc/Hz	200 kHz offset
PSPUR	Spurious Emissions	—	—	-54	dBm	47 MHz < f < 74 MHz 87.5 MHz < f < 118 MHz 174 MHz < f < 230 MHz 470 MHz < f < 862 MHz RBW = 100 kHz
		—	—	-36	dBm	f < 1 GHz RBW = 100 kHz
		—	—	-30	dBm	f > 1 GHz RBW = 1 MHz

rfPIC12F675

NOTES:

14.0 DC AND AC CHARACTERISTICS GRAPHS AND TABLES

The graphs and tables provided in this section are for **design guidance** and are **not tested**.

In some graphs or tables, the data presented are **outside specified operating range** (i.e., outside specified V_{DD} range). This is for **information only** and devices are ensured to operate properly only within the specified range.

The data presented in this section is a **statistical summary** of data collected on units from different lots over a period of time and matrix samples. 'Typical' represents the mean of the distribution at 25°C. 'Max' or 'min' represents (mean + 3σ) or (mean - 3σ) respectively, where σ is standard deviation, over the whole temperature range.

FIGURE 14-1: TYPICAL IPD vs. V_{DD} OVER TEMP (-40°C TO +25°C)

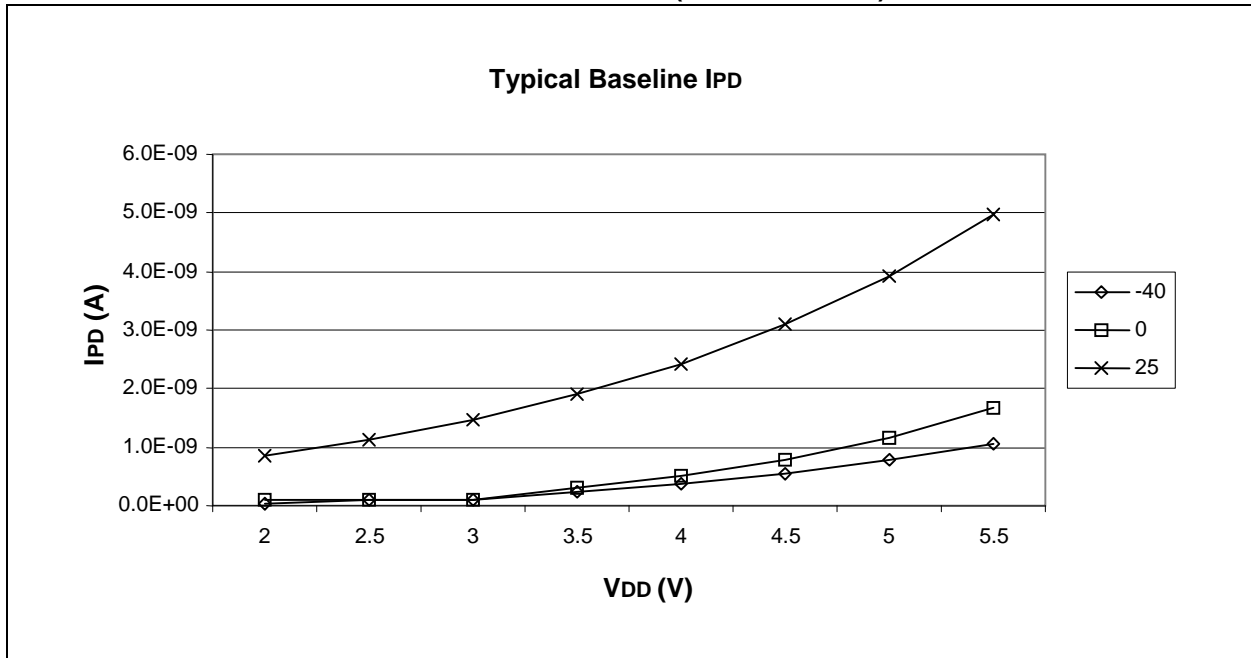
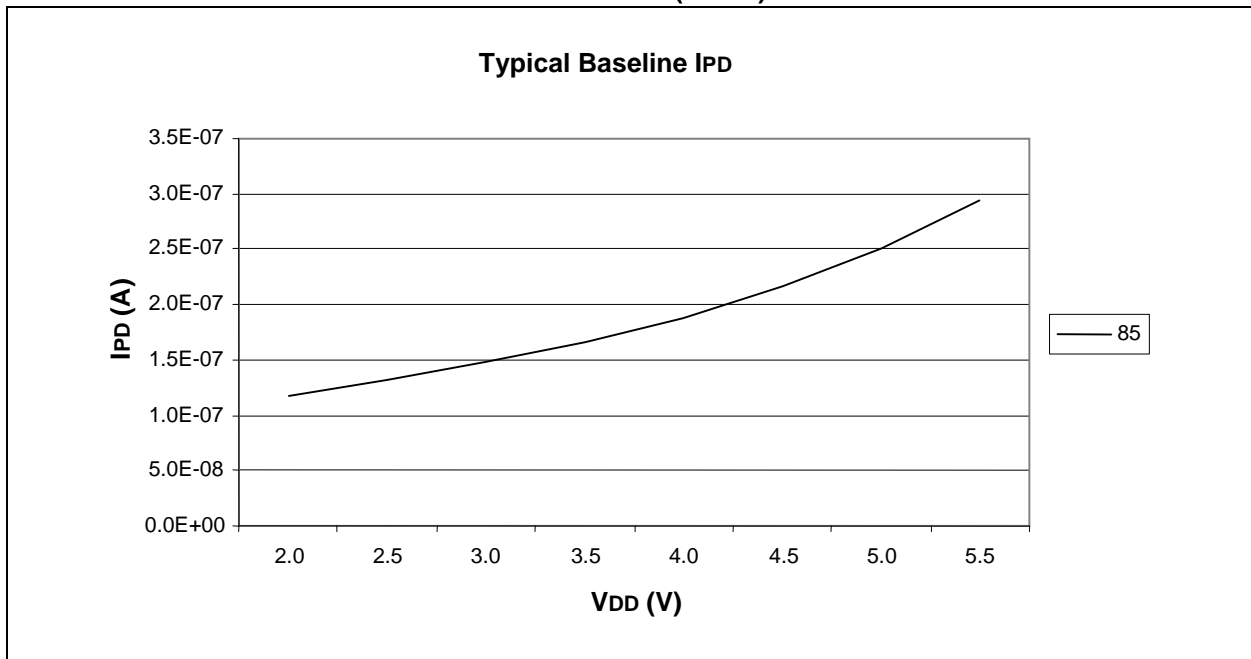

FIGURE 14-2: TYPICAL IPD vs. V_{DD} OVER TEMP (+85°C)



rfPIC12F675

FIGURE 14-3: TYPICAL IPD vs. VDD OVER TEMP (+125°C)

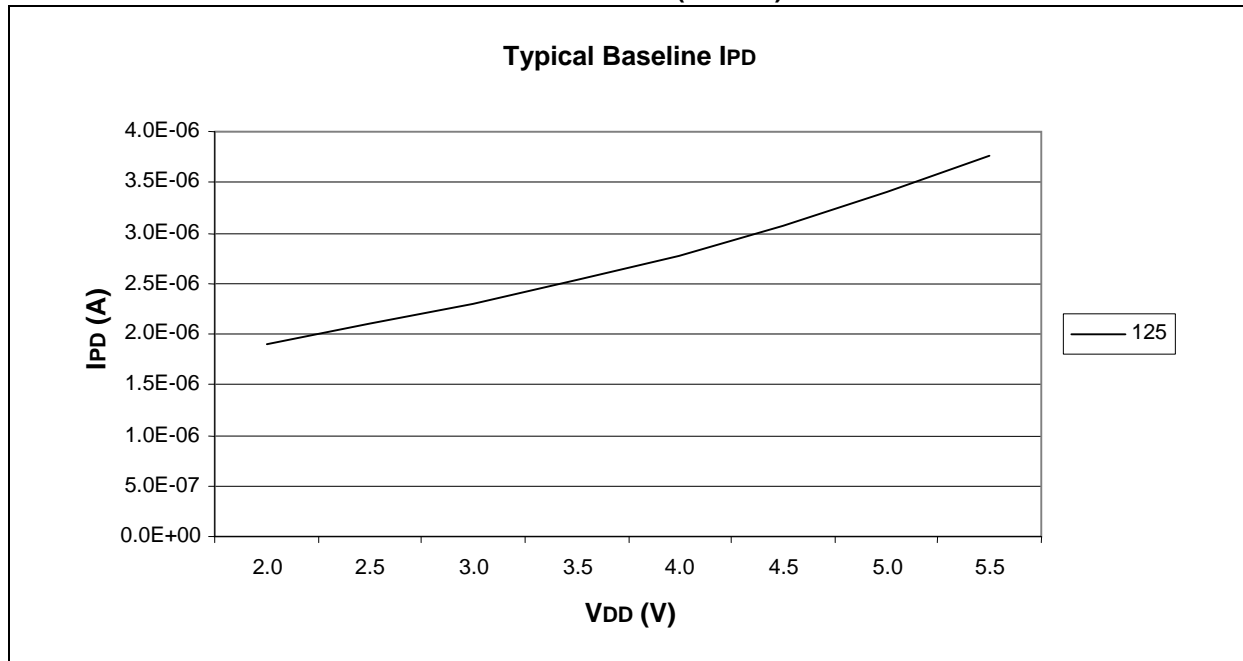

FIGURE 14-4: MAXIMUM IPD vs. VDD OVER TEMP (-40°C TO +25°C)

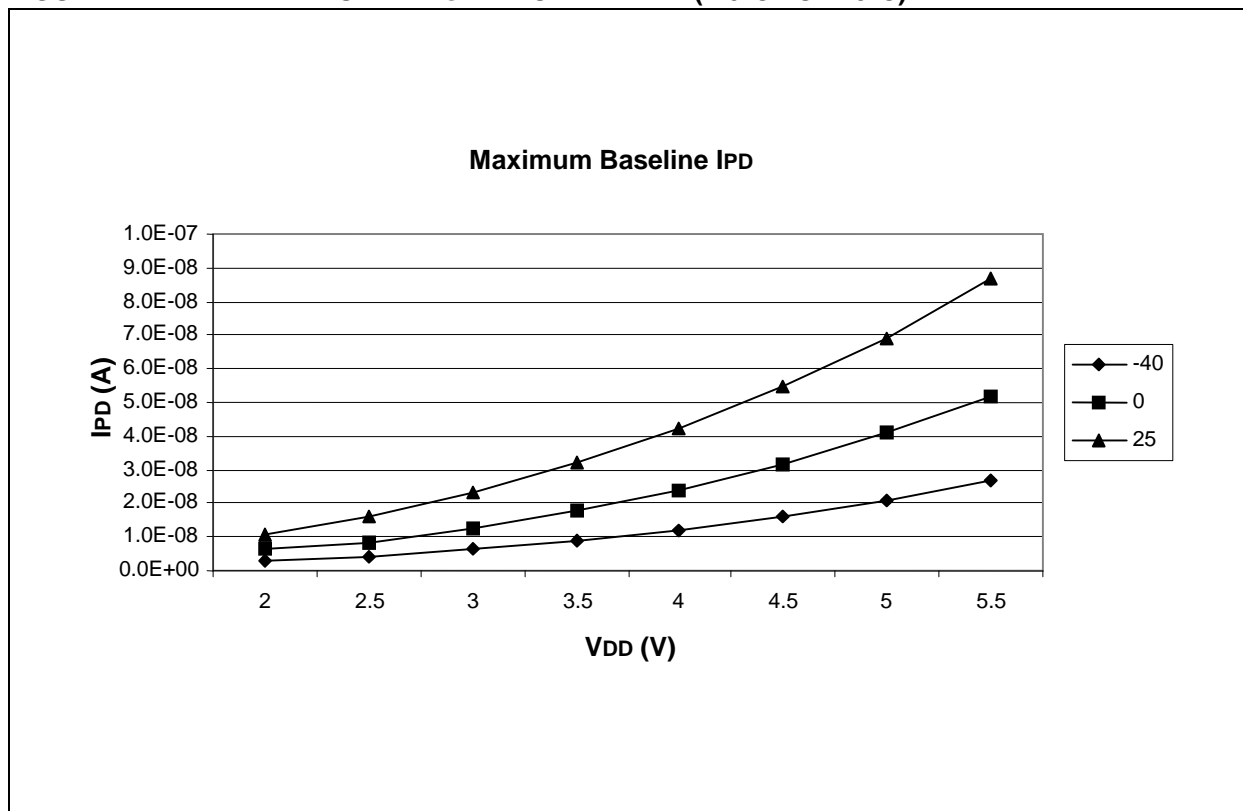

FIGURE 14-5: MAXIMUM IPD vs. VDD OVER TEMP (+85°C)

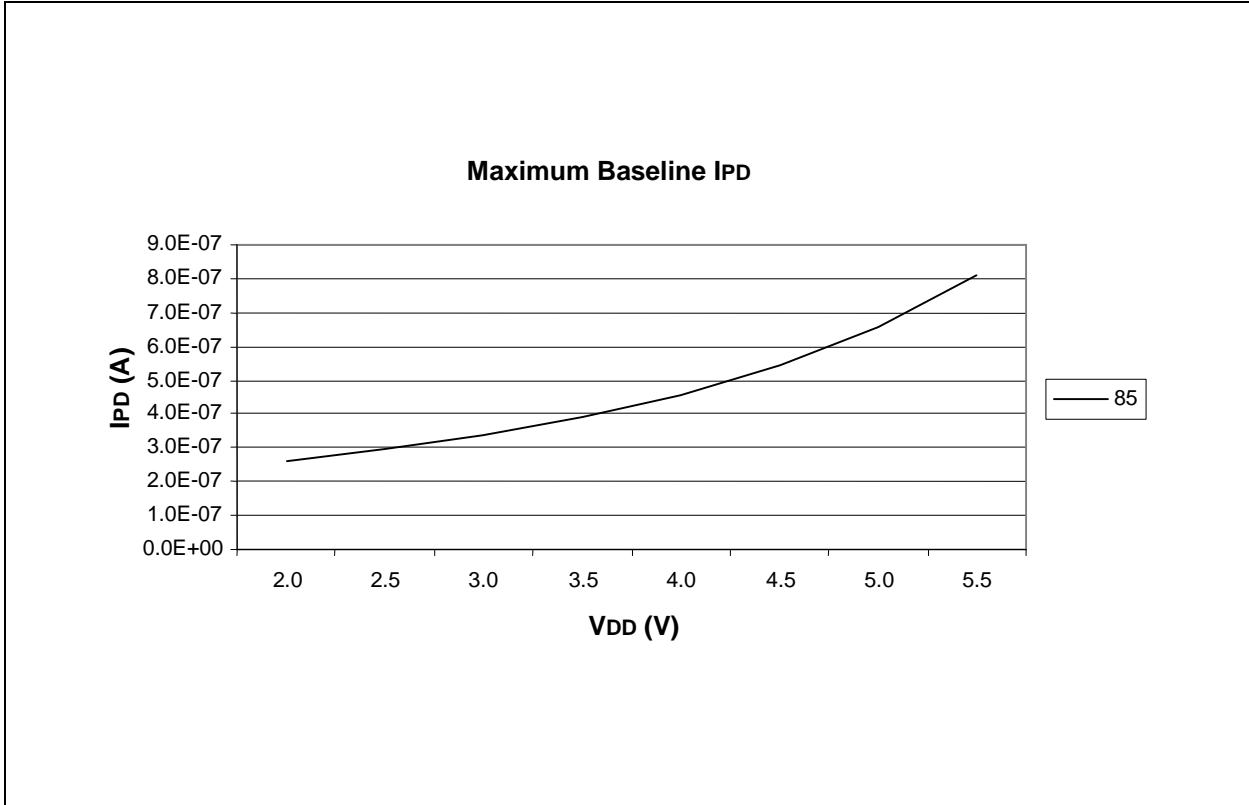
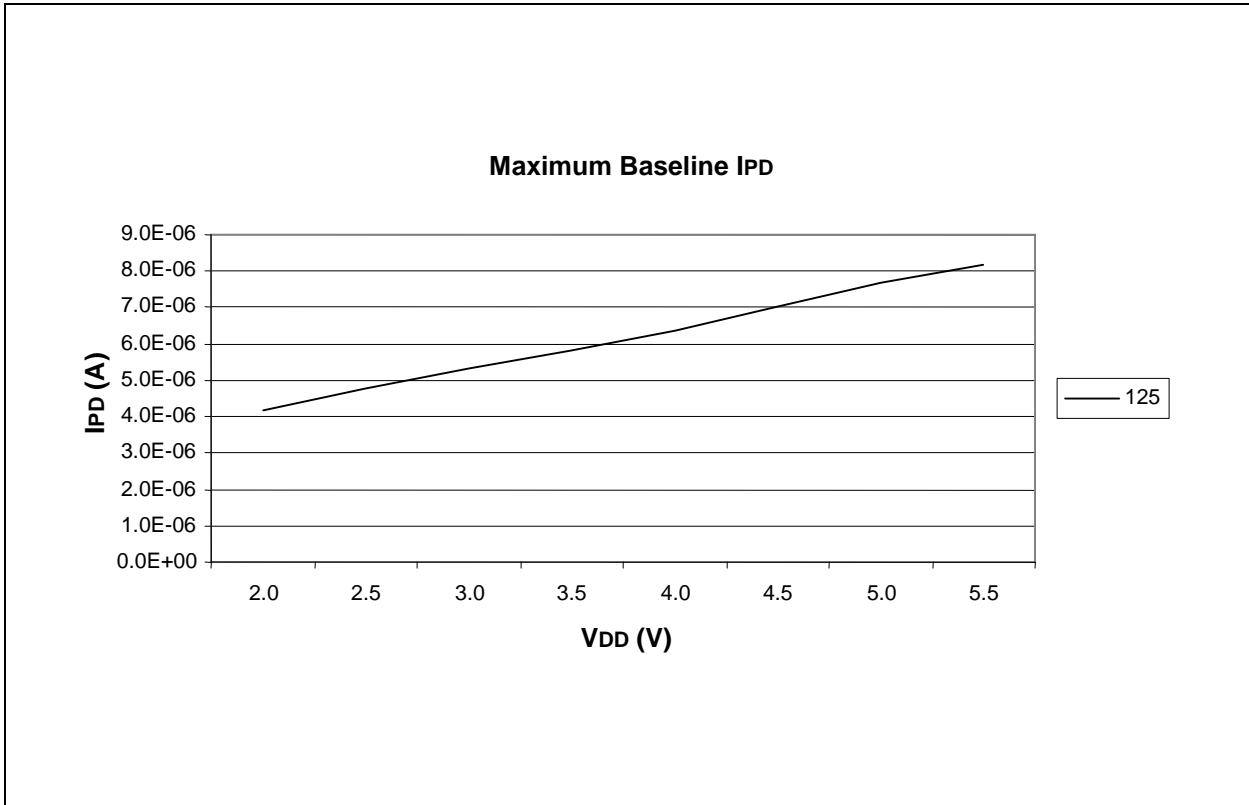

FIGURE 14-6: MAXIMUM IPD vs. VDD OVER TEMP (+125°C)



rfPIC12F675

FIGURE 14-7: TYPICAL IPD WITH BOD ENABLED vs. VDD OVER TEMP (-40°C TO +125°C)

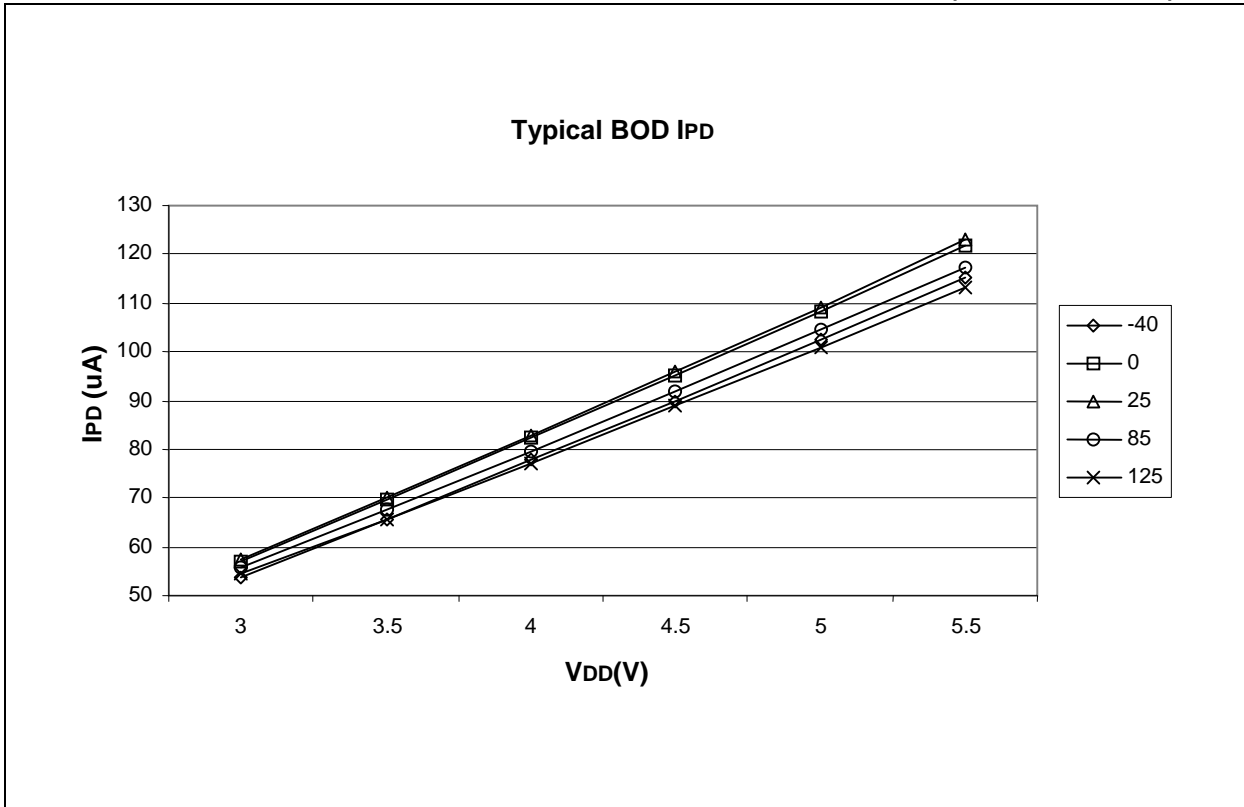

FIGURE 14-8: TYPICAL IPD WITH CMP ENABLED vs. VDD OVER TEMP (-40°C TO +125°C)

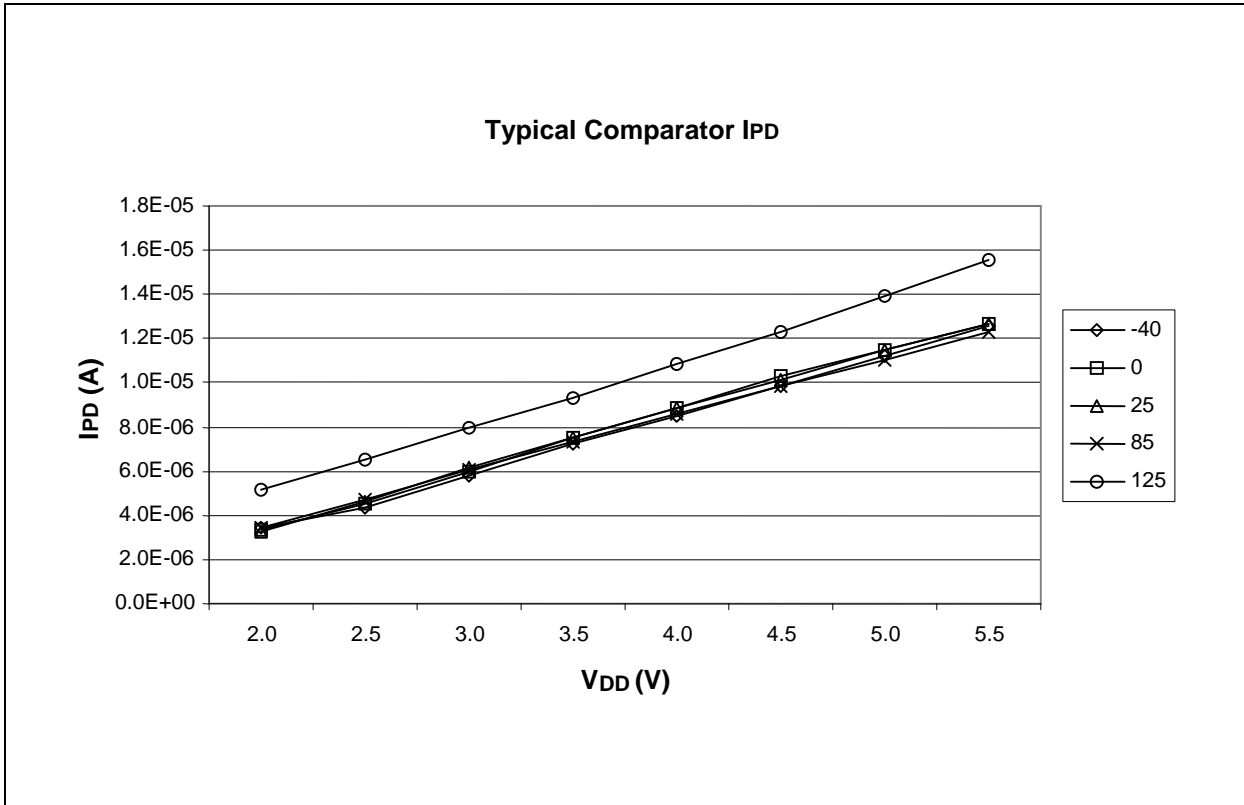

FIGURE 14-9: TYPICAL IPD WITH A/D ENABLED vs. VDD OVER TEMP (-40°C TO +25°C)

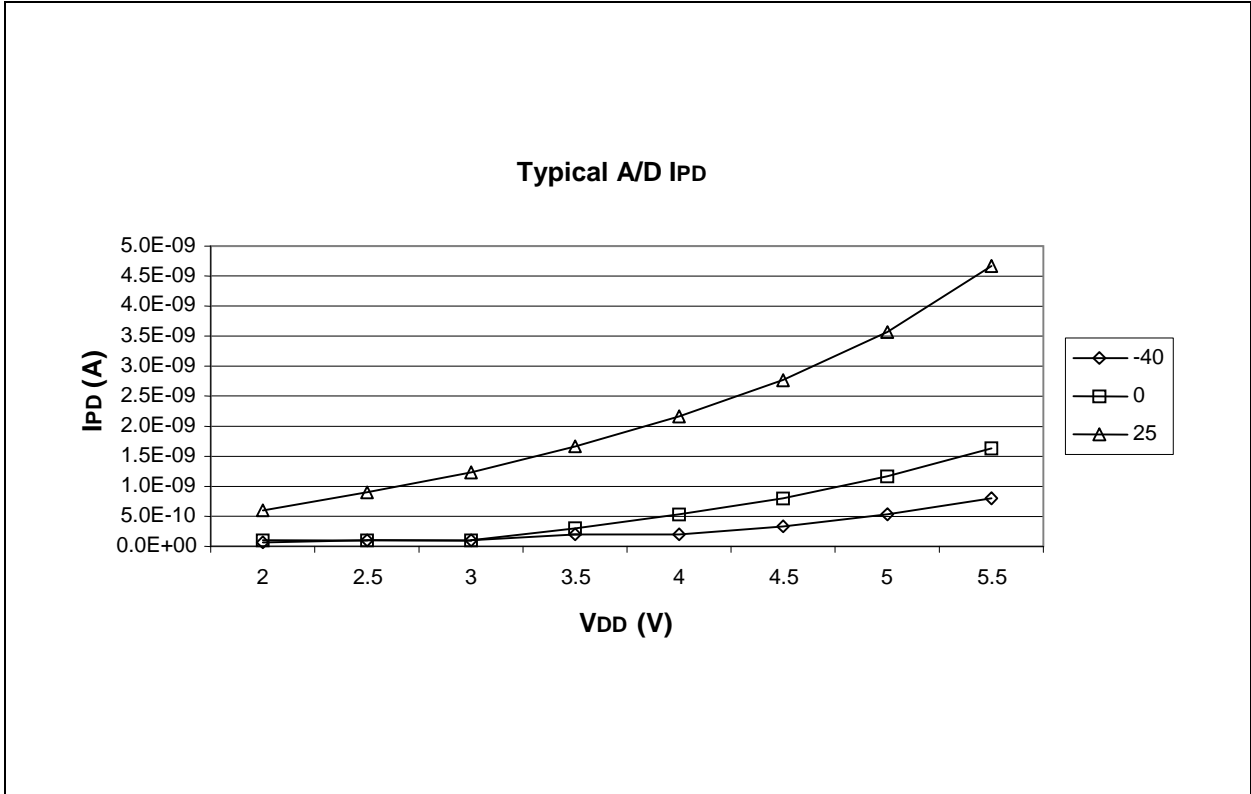
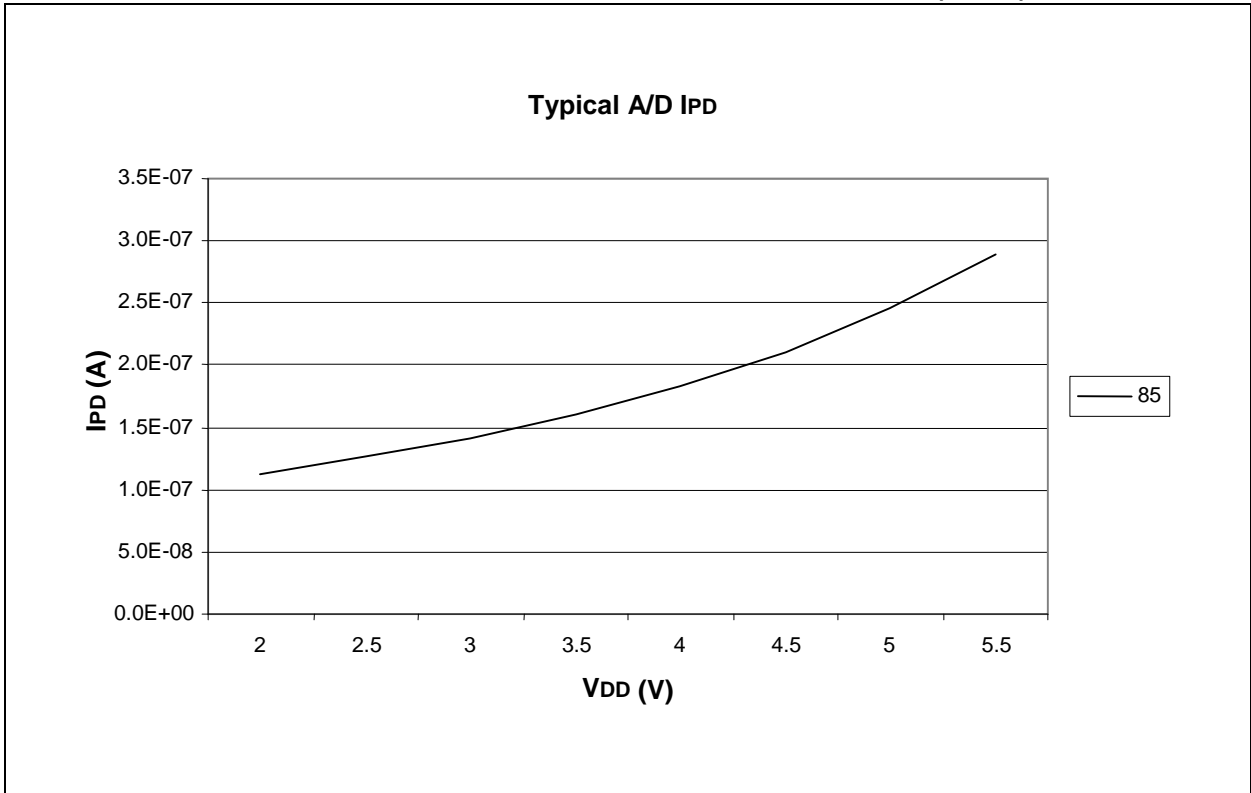

FIGURE 14-10: TYPICAL IPD WITH A/D ENABLED vs. VDD OVER TEMP (+85°C)



rfPIC12F675

FIGURE 14-11: TYPICAL IPD WITH A/D ENABLED vs. VDD OVER TEMP (+125°C)

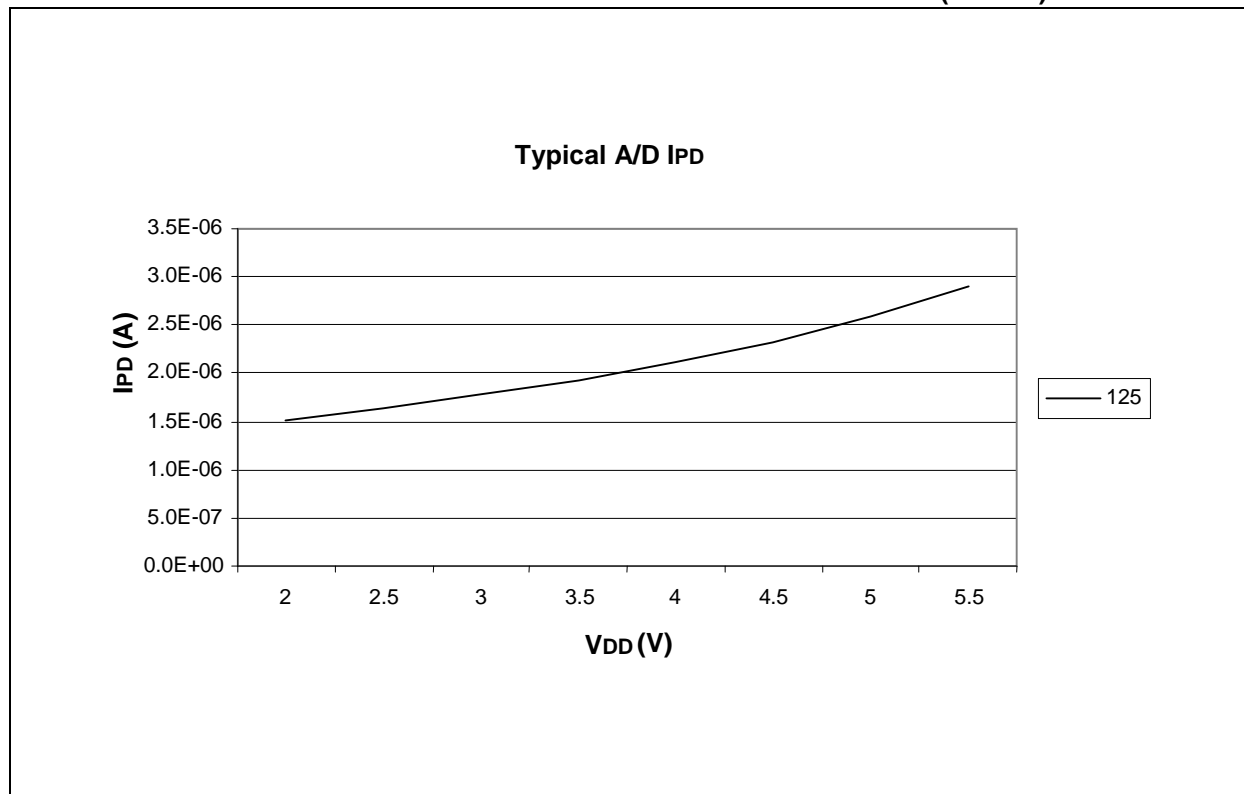

FIGURE 14-12: TYPICAL IPD WITH T1 OSC ENABLED vs. VDD OVER TEMP (-40°C TO +125°C), 32 KHZ, C1 AND C2=50 pF)

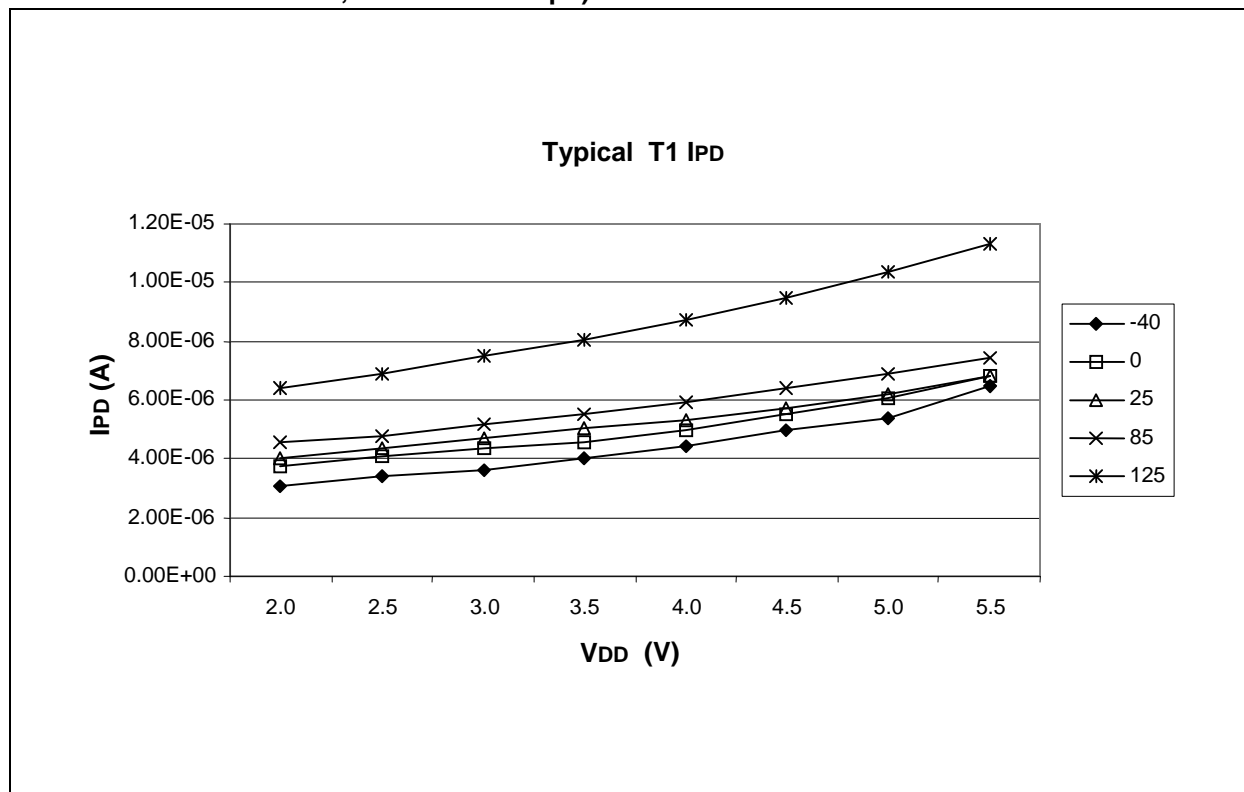

FIGURE 14-13: TYPICAL IPD WITH CVREF ENABLED vs. VDD OVER TEMP (-40°C TO +125°C)

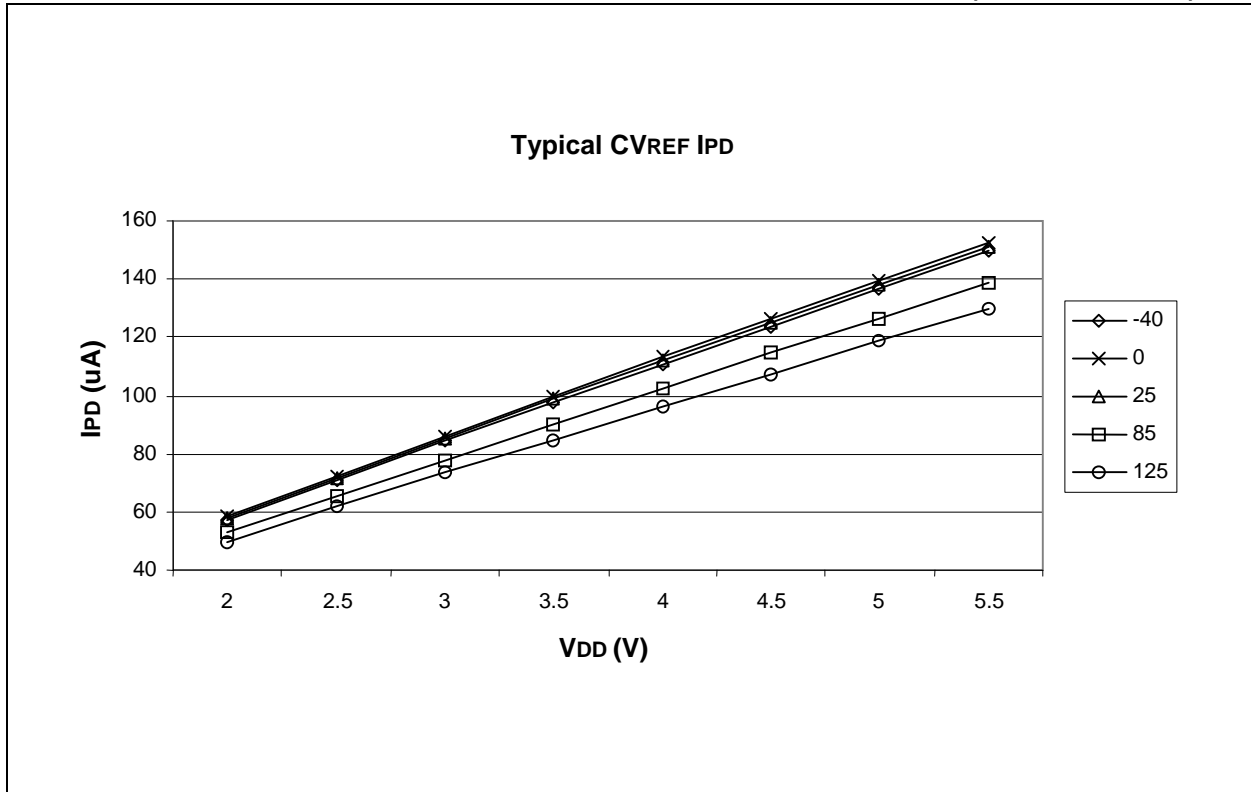
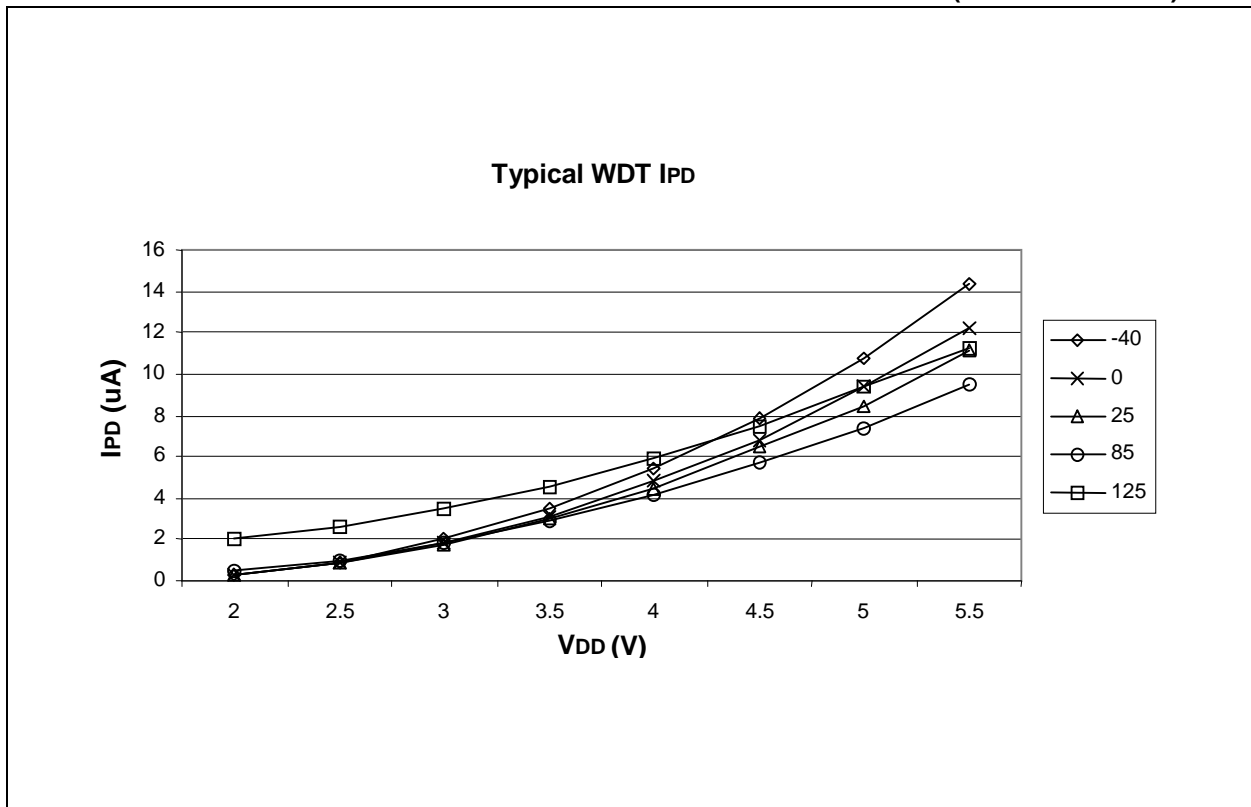

FIGURE 14-14: TYPICAL IPD WITH WDT ENABLED vs. VDD OVER TEMP (-40°C TO +125°C)



rfPIC12F675

FIGURE 14-15: MAXIMUM AND MINIMUM INTOSC FREQ vs. TEMPERATURE WITH 0.1 μ F AND 0.01 μ F DECOUPLING ($V_{DD} = 3.5V$)

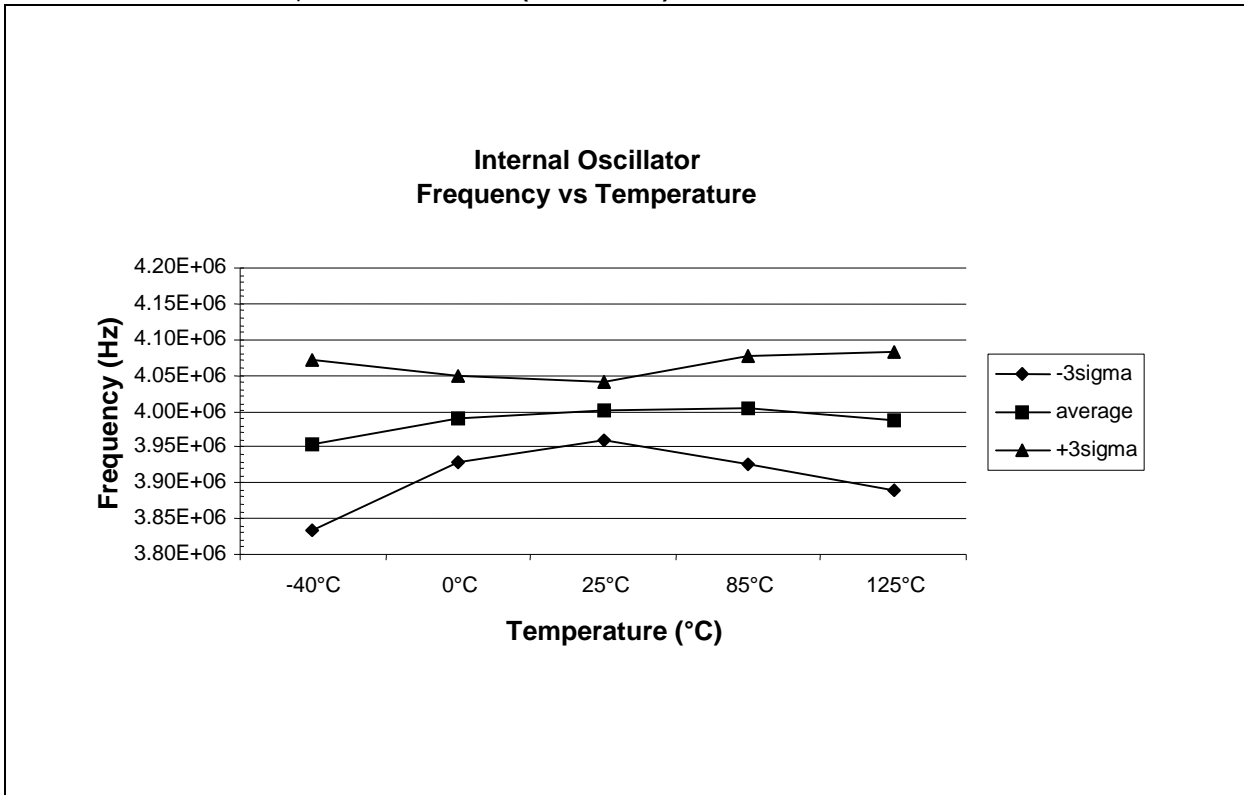

FIGURE 14-16: MAXIMUM AND MINIMUM INTOSC FREQ vs. V_{DD} WITH 0.1 μ F AND 0.01 μ F DECOUPLING (+25°C)

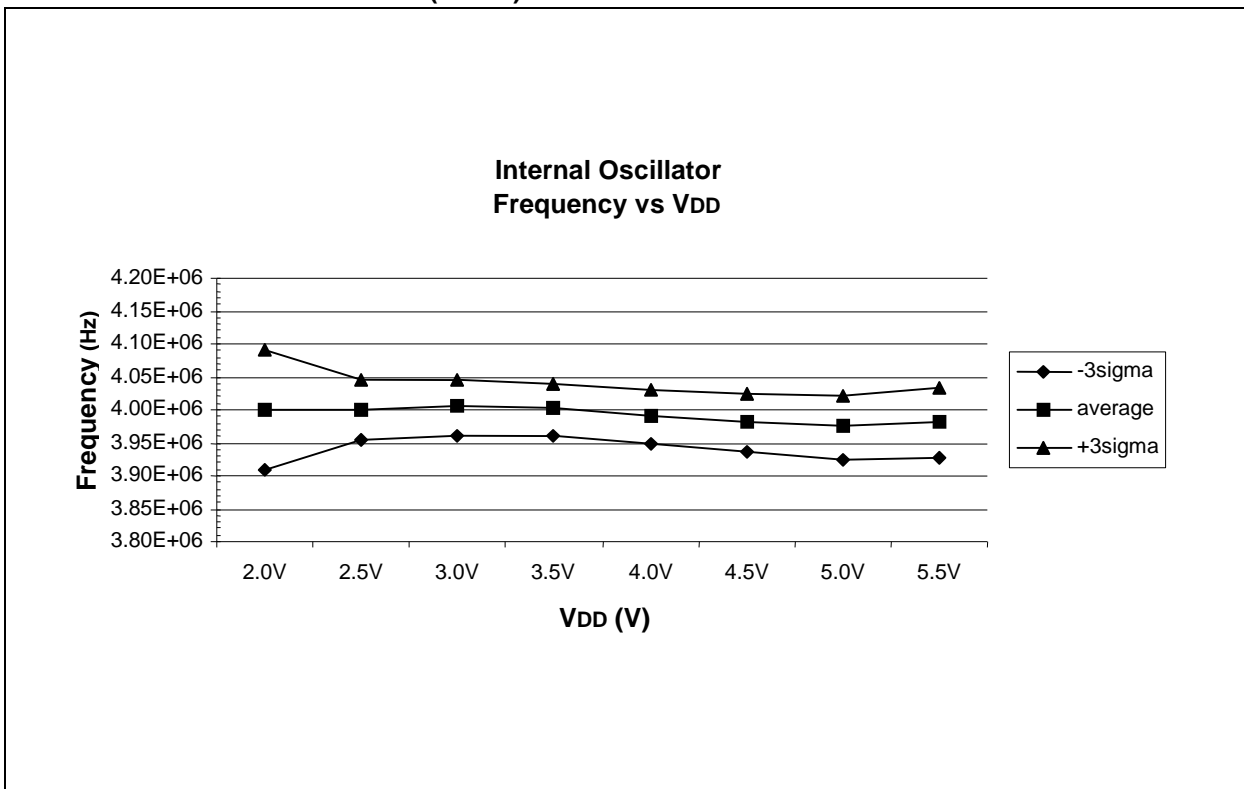
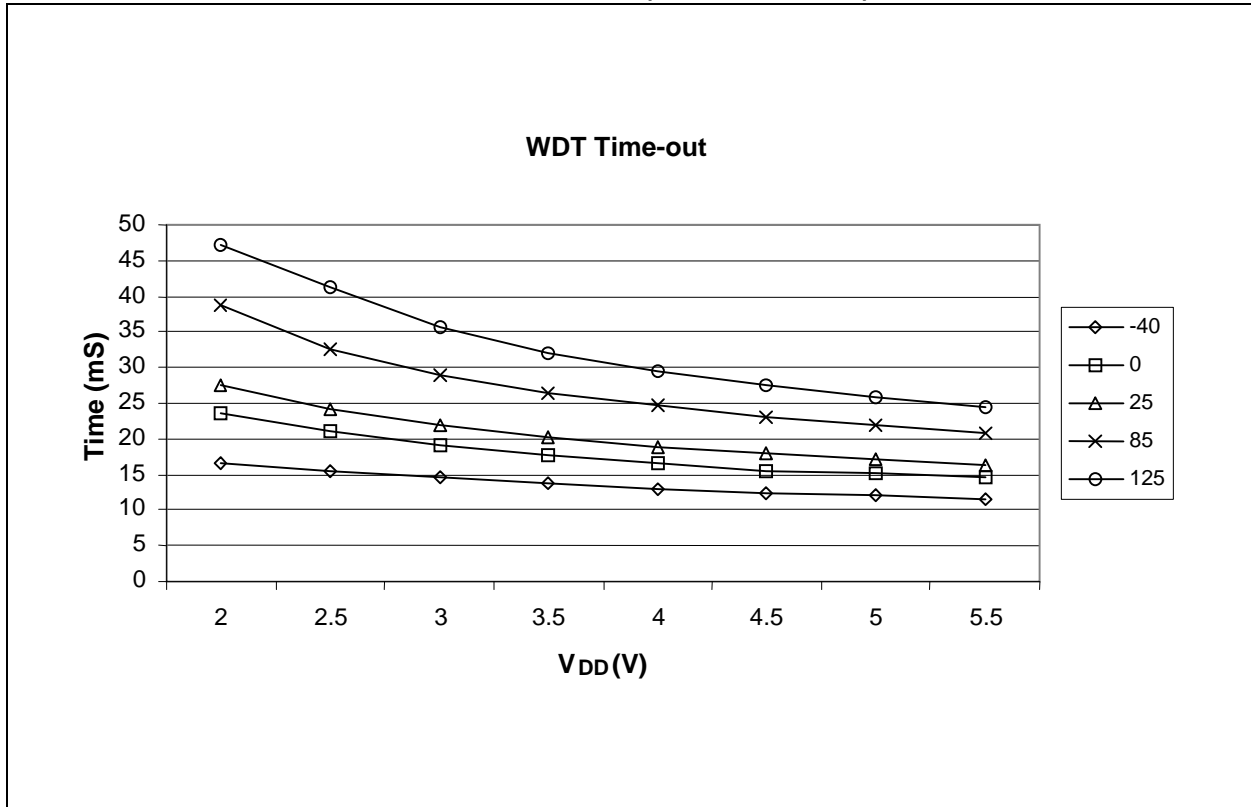

FIGURE 14-17: TYPICAL WDT PERIOD vs. V_{DD} (-40°C TO +125°C)



rfPIC12F675

NOTES:

15.0 PACKAGING INFORMATION

15.1 Package Marking Information

20-Lead SSOP

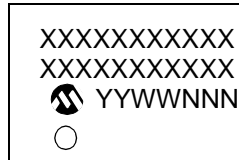

Example

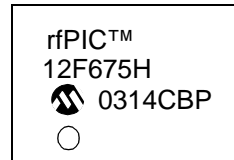

Legend:	XX...X	Customer-specific information
	Y	Year code (last digit of calendar year)
	YY	Year code (last 2 digits of calendar year)
	WW	Week code (week of January 1 is week '01')
	NNN	Alphanumeric traceability code
	(e3)	Pb-free JEDEC designator for Matte Tin (Sn)
	*	This package is Pb-free. The Pb-free JEDEC designator (e3) can be found on the outer packaging for this package.

Note: In the event the full Microchip part number cannot be marked on one line, it will be carried over to the next line, thus limiting the number of available characters for customer-specific information.

rfPIC12F675

Package Type: 20-Lead SSOP

20-Lead Plastic Shrink Small Outline (SS) - 209 mil, 5.30 mm (SSOP)

Note: For the most current package drawings, please see the Microchip Packaging Specification located at <http://www.microchip.com/packaging>

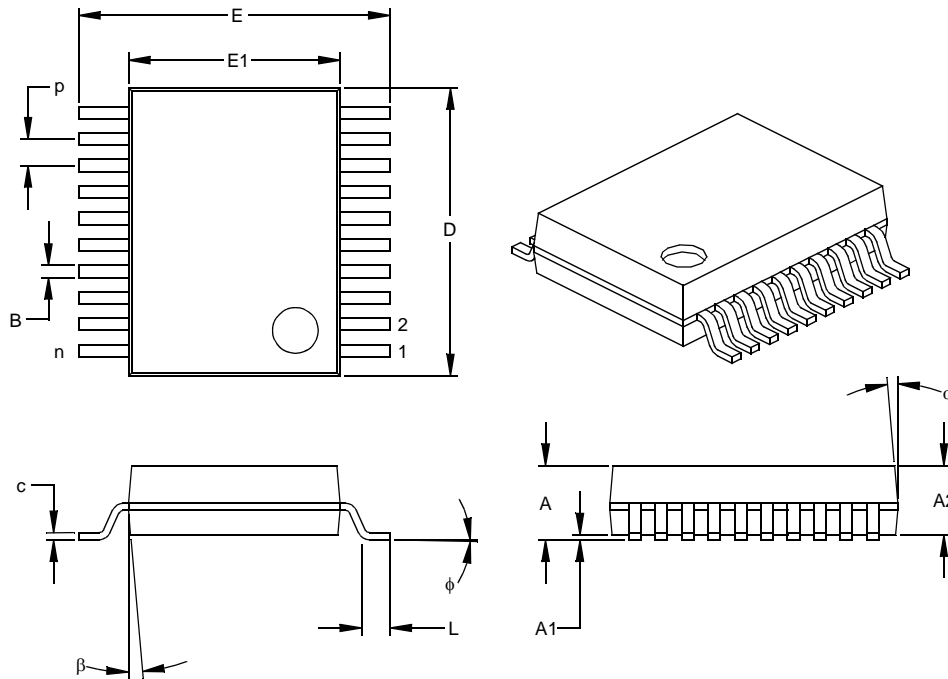

Dimension Limits	Units	INCHES*			MILLIMETERS		
		MIN	NOM	MAX	MIN	NOM	MAX
Number of Pins	n		20			20	
Pitch	p		.026			0.65	
Overall Height	A	.068	.073	.078	1.73	1.85	1.98
Molded Package Thickness	A2	.064	.068	.072	1.63	1.73	1.83
Standoff §	A1	.002	.006	.010	0.05	0.15	0.25
Overall Width	E	.299	.309	.322	7.59	7.85	8.18
Molded Package Width	E1	.201	.207	.212	5.11	5.25	5.38
Overall Length	D	.278	.284	.289	7.06	7.20	7.34
Foot Length	L	.022	.030	.037	0.56	0.75	0.94
Lead Thickness	c	.004	.007	.010	0.10	0.18	0.25
Foot Angle	φ	0	4	8	0.00	101.60	203.20
Lead Width	B	.010	.013	.015	0.25	0.32	0.38
Mold Draft Angle Top	α	0	5	10	0	5	10
Mold Draft Angle Bottom	β	0	5	10	0	5	10

* Controlling Parameter

§ Significant Characteristic

Notes:

Dimensions D and E1 do not include mold flash or protrusions. Mold flash or protrusions shall not exceed

.010" (0.254mm) per side.

JEDEC Equivalent: MO-150

Drawing No. C04-072

APPENDIX A: DATA SHEET REVISION HISTORY

Revision A

This is a new data sheet.

Revision B

Added a note to each package outline drawing.

rfPIC12F675

NOTES:

INDEX

A

A/D	39
Acquisition Requirements	43
Block Diagram	39
Calculating Acquisition Time	43
Configuration and Operation	39
Effects of a RESET	44
Internal Sampling Switch (Rss) Impedance	43
Operation During SLEEP	44
PIC12F675 Converter Characteristics	106
Source Impedance	43
Summary of Registers	44
Absolute Maximum Ratings	87
AC Characteristics	
Industrial and Extended	99
Additional Pin Functions	17
Interrupt-on-Change	19
Weak Pull-up	17
Analog Input Connection Considerations	36
Analog-to-Digital Converter. <i>See</i> A/D	
Assembler	
MPASM Assembler	81

B

Block Diagram	
TMR0/WDT Prescaler	25
Block Diagrams	
Analog Input Mode	36
Analog Input Model	43
Comparator Output	36
Comparator Voltage Reference	37
GP0 and GP1 Pins	20
GP2	21
GP3	21
GP4	22
GP5	22
On-Chip Reset Circuit	59
RC Oscillator Mode	58
Timer1	28
Watchdog Timer	69
Brown-out	
Associated Registers	62
Brown-out Detect (BOD)	61
Brown-out Detect Timing and Characteristics	102

C

C Compilers	
MPLAB C17	82
MPLAB C18	82
MPLAB C30	82
Calibrated Internal RC Frequencies	100
CLKOUT	58
Code Examples	
Changing Prescaler	27
Data EEPROM Read	47
Data EEPROM Write	47
Initializing GPIO	17
Saving STATUS and W Registers in RAM	68
Write Verify	47
Code Protection	69
Comparator	33
Associated Registers	38
Configuration	35
Effects of a RESET	37
I/O Operating Modes	35
Interrupts	38

Operation	34
Operation During SLEEP	37
Output	36
Reference	37
Response Time	37
Comparator Specifications	105, 108, 109, 110, 111
Comparator Voltage Reference Specifications	105
Configuration Bits	56
Configuring the Voltage Reference	37
Crystal Operation	57
Crystal Oscillator	50

D

Data EEPROM Memory	
Associated Registers/Bits	48
Code Protection	48
EEADR Register	45
EECON1 Register	45
EECON2 Register	45
EEDATA Register	45
Data Memory Organization	5
DC Characteristics	
Extended and Industrial	96
Industrial	90
Demonstration Boards	
PICDEM 1	84
PICDEM 17	84
PICDEM 18R PIC18C601/801	85
PICDEM 2 Plus	84
PICDEM 3 PIC16C92X	84
PICDEM 4	84
PICDEM LIN PIC16C43X	85
PICDEM USB PIC16C7X5	85
PICDEM.net Internet/Ethernet	84
Development Support	81
Device Overview	3

E

EEPROM Data Memory	
Reading	47
Spurious Write	47
Write Verify	47
Writing	47
Electrical Specifications	87
Errata	2
Evaluation and Programming Tools	85

F

Firmware Instructions	73
-----------------------------	----

G

General Purpose Register File	5
GPIO	
Associated Registers	23
GPIO Port	17
GPIO, TRISIO Registers	17

I

ID Locations	69
In-Circuit Debugger	71
In-Circuit Serial Programming	71
Indirect Addressing, INDF and FSR Registers	16
Instruction Format	73
Instruction Set	73
ADDLW	75
ADDWF	75
ANDLW	75
ANDWF	75
BCF	75

BSF	75	Phase-Locked Loop (PLL)	53
BTFSC	75	PICkit 1 FLASH Starter Kit	85
BTFSS	75	PICSTART Plus Development Programmer	83
CALL	76	Pin Descriptions and Diagrams	20
CLRF	76	Power Amplifier	53
CLRWF	76	Power Control/Status Register (PCON)	61
CLRWDT	76	Power Select (Table)	53
COMF	76	Power-Down Mode (SLEEP)	70
DECF	76	Power-on Reset (POR)	60
DECFSZ	77	Power-up Timer (PWRT)	60
GOTO	77	Prescaler	27
INCF	77	Switching Prescaler Assignment	27
INCFSZ	77	PRO MATE II Universal Device Programmer	83
IORLW	77	Program Memory Organization	5
IORWF	77	Programming, Device Instructions	73
MOVF	78	R	
MOVLW	78	RC Oscillator	58
MOVWF	78	READ-MODIFY-WRITE OPERATIONS	73
NOP	78	Registers	
RETFIE	78	ADCON0 (A/D Control)	41
RETLW	78	ANSEL (Analog Select)	42
RETURN	79	CMCON (Comparator Control)	33
RLF	79	CONFIG (Configuration Word)	56
RRF	79	EEADR (EEPROM Address)	45
SLEEP	79	ECON1 (EEPROM Control)	46
SUBLW	79	EEDAT (EEPROM Data)	45
SUBWF	79	INTCON (Interrupt Control)	11
SWAPF	80	IOCB (Interrupt-on-Change GPIO)	19
XORLW	80	Maps	
XORWF	80	PIC12F629	6
Summary Table	74	PIC12F675	6
Internal 4 MHz Oscillator	58	OPTION_REG (Option)	10, 26
Internal Sampling Switch (R _{ss}) Impedance	43	OSCCAL (Oscillator Calibration)	14
Interrupts	65	PCON (Power Control)	14
A/D Converter	67	PIE1 (Peripheral Interrupt Enable 1)	12
Comparator	67	PIR1 (Peripheral Interrupt 1)	13
Context Saving	68	STATUS	9
GP2/INT	67	T1CON (Timer1 Control)	30
GPIO	67	VRCON (Voltage Reference Control)	38
Summary of Registers	68	WPU (Weak Pull-up)	18
TMR0	67	RESET	59
M		Revision History	125
MCLR	60	S	
Memory Organization		Software Simulator (MPLAB SIM)	82
Data EEPROM Memory	45	Software Simulator (MPLAB SIM30)	82
Mode Control Logic	54	Special Features of the CPU	55
MPLAB ASM30 Assembler, Linker, Librarian	82	Special Function Registers	6
MPLAB ICD 2 In-Circuit Debugger	83	Special Functions Registers Summary	7
MPLAB ICE 2000 High Performance Universal		T	
In-Circuit Emulator	83	Time-out Sequence	61
MPLAB ICE 4000 High Performance Universal		Timer0	25
In-Circuit Emulator	83	Associated Registers	27
MPLAB Integrated Development Environment		External Clock	26
Software	81	Interrupt	25
MPLINK Object Linker/MPLIB Object Librarian	82	Operation	25
O		T0CKI	26
OPCODE Field Descriptions	73	Timer1	
Oscillator Configurations	57	Associated Registers	31
Oscillator Start-up Timer (OST)	60	Asynchronous Counter Mode	31
P		Reading and Writing	31
Package Marking Information	123	Interrupt	29
Packaging Information	123	Modes of Operations	29
PCL and PCLATH	15	Operation During SLEEP	31
Computed GOTO	15	Oscillator	31
Stack	15	Prescaler	29

Timer1 Module with Gate Control	28
Timing Diagrams	
CLKOUT and I/O.....	101
External Clock.....	99
INT Pin Interrupt.....	67
PIC12F675 A/D Conversion (Normal Mode).....	107
PIC12F675 A/D Conversion Timing (SLEEP Mode).....	108
RESET, Watchdog Timer, Oscillator Start-up	
Timer and Power-up Timer	102
Time-out Sequence on Power-up (MCLR not Tied to VDD)/	
Case 1	64
Case 2	64
Time-out Sequence on Power-up (MCLR Tied to VDD)	64
Timer0 and Timer1 External Clock	104
Timer1 Incrementing Edge.....	29
Timing Parameter Symbology.....	98
U	
UHF ASK/FSK Transmitter	
CEPT	49
FCC.....	49
Radio Frequency.....	49
Transmitter.....	49
V	
Voltage Reference Accuracy/Error	37
W	
Watchdog Timer	
Summary of Registers	69
Watchdog Timer (WDT)	68
WWW, On-Line Support	2

rfPIC12F675

NOTES:

THE MICROCHIP WEB SITE

Microchip provides online support via our WWW site at www.microchip.com. This web site is used as a means to make files and information easily available to customers. Accessible by using your favorite Internet browser, the web site contains the following information:

- **Product Support** – Data sheets and errata, application notes and sample programs, design resources, user's guides and hardware support documents, latest software releases and archived software
- **General Technical Support** – Frequently Asked Questions (FAQ), technical support requests, online discussion groups, Microchip consultant program member listing
- **Business of Microchip** – Product selector and ordering guides, latest Microchip press releases, listing of seminars and events, listings of Microchip sales offices, distributors and factory representatives

CUSTOMER CHANGE NOTIFICATION SERVICE

Microchip's customer notification service helps keep customers current on Microchip products. Subscribers will receive e-mail notification whenever there are changes, updates, revisions or errata related to a specified product family or development tool of interest.

To register, access the Microchip web site at www.microchip.com. Under "Support", click on "Customer Change Notification" and follow the registration instructions.

CUSTOMER SUPPORT

Users of Microchip products can receive assistance through several channels:

- Distributor or Representative
- Local Sales Office
- Field Application Engineer (FAE)
- Technical Support

Customers should contact their distributor, representative or field application engineer (FAE) for support. Local sales offices are also available to help customers. A listing of sales offices and locations is included in the back of this document.

Technical support is available through the web site at: <http://microchip.com/support>

READER RESPONSE

It is our intention to provide you with the best documentation possible to ensure successful use of your Microchip product. If you wish to provide your comments on organization, clarity, subject matter, and ways in which our documentation can better serve you, please FAX your comments to the Technical Publications Manager at (480) 792-4150.

Please list the following information, and use this outline to provide us with your comments about this document.

TO: Technical Publications Manager Total Pages Sent _____

RE: Reader Response

From: Name _____

Company _____

Address _____

City / State / ZIP / Country _____

Telephone: (_____) _____ - _____ FAX: (_____) _____ - _____

Application (optional):

Would you like a reply? Y N

Device:

Literature Number: DS70091B

Questions:

1. What are the best features of this document?

2. How does this document meet your hardware and software development needs?

3. Do you find the organization of this document easy to follow? If not, why?

4. What additions to the document do you think would enhance the structure and subject?

5. What deletions from the document could be made without affecting the overall usefulness?

6. Is there any incorrect or misleading information (what and where)?

7. How would you improve this document?

PRODUCT IDENTIFICATION SYSTEM

To order or obtain information, e.g., on pricing or delivery, refer to the factory or the listed sales office.

<u>PART NO.</u>	<u>X</u>	<u>/XX</u>	<u>XXX</u>
Device	Temperature Range	Package	Pattern
Device	: Standard VDD range T: (Tape and Reel)		
Temperature Range	I = -40°C to +85°C E = -40°C to +125°C		
Package	SS = SSOP		
Pattern	3-Digit Pattern Code for QTP (blank otherwise)		

Examples:

a) rfPIC12F675F – E/SS 301 = Extended Temp., SSOP package, 434 MHz, QTP pattern #301

b) rfPIC12F675FHT – I/SS = Industrial Temp., SSOP package, 868 MHz, Tape and Reel

* JW Devices are UV erasable and can be programmed to any device configuration. JW Devices meet the electrical requirement of each oscillator type.

Sales and Support

Data Sheets

Products supported by a preliminary Data Sheet may have an errata sheet describing minor operational differences and recommended workarounds. To determine if an errata sheet exists for a particular device, please contact one of the following:

1. Your local Microchip sales office
2. The Microchip Worldwide Site (www.microchip.com)

Note the following details of the code protection feature on Microchip devices:

- Microchip products meet the specification contained in their particular Microchip Data Sheet.
- Microchip believes that its family of products is one of the most secure families of its kind on the market today, when used in the intended manner and under normal conditions.
- There are dishonest and possibly illegal methods used to breach the code protection feature. All of these methods, to our knowledge, require using the Microchip products in a manner outside the operating specifications contained in Microchip's Data Sheets. Most likely, the person doing so is engaged in theft of intellectual property.
- Microchip is willing to work with the customer who is concerned about the integrity of their code.
- Neither Microchip nor any other semiconductor manufacturer can guarantee the security of their code. Code protection does not mean that we are guaranteeing the product as “unbreakable.”

Code protection is constantly evolving. We at Microchip are committed to continuously improving the code protection features of our products. Attempts to break Microchip's code protection feature may be a violation of the Digital Millennium Copyright Act. If such acts allow unauthorized access to your software or other copyrighted work, you may have a right to sue for relief under that Act.

Information contained in this publication regarding device applications and the like is provided only for your convenience and may be superseded by updates. It is your responsibility to ensure that your application meets with your specifications. MICROCHIP MAKES NO REPRESENTATIONS OR WARRANTIES OF ANY KIND WHETHER EXPRESS OR IMPLIED, WRITTEN OR ORAL, STATUTORY OR OTHERWISE, RELATED TO THE INFORMATION, INCLUDING BUT NOT LIMITED TO ITS CONDITION, QUALITY, PERFORMANCE, MERCHANTABILITY OR FITNESS FOR PURPOSE. Microchip disclaims all liability arising from this information and its use. Use of Microchip devices in life support and/or safety applications is entirely at the buyer's risk, and the buyer agrees to defend, indemnify and hold harmless Microchip from any and all damages, claims, suits, or expenses resulting from such use. No licenses are conveyed, implicitly or otherwise, under any Microchip intellectual property rights.

Trademarks

The Microchip name and logo, the Microchip logo, dsPIC, FlashFlex, KEELOQ, KEELOQ logo, MPLAB, PIC, PICmicro, PICSTART, PIC³² logo, rPIC, SST, SST Logo, SuperFlash and UNI/O are registered trademarks of Microchip Technology Incorporated in the U.S.A. and other countries.

FilterLab, Hampshire, HI-TECH C, Linear Active Thermistor, MTP, SEEVAL and The Embedded Control Solutions Company are registered trademarks of Microchip Technology Incorporated in the U.S.A.

Silicon Storage Technology is a registered trademark of Microchip Technology Inc. in other countries.

Analog-for-the-Digital Age, Application Maestro, BodyCom, chipKIT, chipKIT logo, CodeGuard, dsPICDEM, dsPICDEM.net, dsPICworks, dsSPEAK, ECAN, ECONOMONITOR, FanSense, HI-TIDE, In-Circuit Serial Programming, ICSP, Mindi, MiWi, MPASM, MPF, MPLAB Certified logo, MPLIB, MPLINK, mTouch, Omniclient Code Generation, PICC, PICC-18, PICDEM, PICDEM.net, PICkit, PICTail, REAL ICE, rLAB, Select Mode, SQI, Serial Quad I/O, Total Endurance, TSHARC, UniWinDriver, WiperLock, ZENA and Z-Scale are trademarks of Microchip Technology Incorporated in the U.S.A. and other countries.

SQTP is a service mark of Microchip Technology Incorporated in the U.S.A.

GestIC and ULPP are registered trademarks of Microchip Technology Germany II GmbH & Co. & KG, a subsidiary of Microchip Technology Inc., in other countries.

All other trademarks mentioned herein are property of their respective companies.

© 2003-2013, Microchip Technology Incorporated, Printed in the U.S.A., All Rights Reserved.

 Printed on recycled paper.

ISBN: 9781620769683

QUALITY MANAGEMENT SYSTEM
CERTIFIED BY DNV
== ISO/TS 16949 ==

Microchip received ISO/TS-16949:2009 certification for its worldwide headquarters, design and wafer fabrication facilities in Chandler and Tempe, Arizona; Gresham, Oregon and design centers in California and India. The Company's quality system processes and procedures are for its PIC[®] MCUs and dsPIC[®] DSCs, KEELOQ[®] code hopping devices, Serial EEPROMs, microperipherals, nonvolatile memory and analog products. In addition, Microchip's quality system for the design and manufacture of development systems is ISO 9001:2000 certified.



MICROCHIP

Worldwide Sales and Service

AMERICAS

Corporate Office
2355 West Chandler Blvd.
Chandler, AZ 85224-6199
Tel: 480-792-7200
Fax: 480-792-7277
Technical Support:
<http://www.microchip.com/support>
Web Address:
www.microchip.com

Atlanta
Duluth, GA
Tel: 678-957-9614
Fax: 678-957-1455

Boston
Westborough, MA
Tel: 774-760-0087
Fax: 774-760-0088

Chicago
Itasca, IL
Tel: 630-285-0071
Fax: 630-285-0075

Cleveland
Independence, OH
Tel: 216-447-0464
Fax: 216-447-0643

Dallas
Addison, TX
Tel: 972-818-7423
Fax: 972-818-2924

Detroit
Farmington Hills, MI
Tel: 248-538-2250
Fax: 248-538-2260

Indianapolis
Noblesville, IN
Tel: 317-773-8323
Fax: 317-773-5453

Los Angeles
Mission Viejo, CA
Tel: 949-462-9523
Fax: 949-462-9608

Santa Clara
Santa Clara, CA
Tel: 408-961-6444
Fax: 408-961-6445

Toronto
Mississauga, Ontario,
Canada
Tel: 905-673-0699
Fax: 905-673-6509

ASIA/PACIFIC

Asia Pacific Office
Suites 3707-14, 37th Floor
Tower 6, The Gateway
Harbour City, Kowloon
Hong Kong
Tel: 852-2401-1200
Fax: 852-2401-3431

Australia - Sydney
Tel: 61-2-9868-6733
Fax: 61-2-9868-6755

China - Beijing
Tel: 86-10-8569-7000
Fax: 86-10-8528-2104

China - Chengdu
Tel: 86-28-8665-5511
Fax: 86-28-8665-7889

China - Chongqing
Tel: 86-23-8980-9588
Fax: 86-23-8980-9500

China - Hangzhou
Tel: 86-571-2819-3187
Fax: 86-571-2819-3189

China - Hong Kong SAR
Tel: 852-2943-5100
Fax: 852-2401-3431

China - Nanjing
Tel: 86-25-8473-2460
Fax: 86-25-8473-2470

China - Qingdao
Tel: 86-532-8502-7355
Fax: 86-532-8502-7205

China - Shanghai
Tel: 86-21-5407-5533
Fax: 86-21-5407-5066

China - Shenyang
Tel: 86-24-2334-2829
Fax: 86-24-2334-2393

China - Shenzhen
Tel: 86-755-8864-2200
Fax: 86-755-8203-1760

China - Wuhan
Tel: 86-27-5980-5300
Fax: 86-27-5980-5118

China - Xian
Tel: 86-29-8833-7252
Fax: 86-29-8833-7256

China - Xiamen
Tel: 86-592-2388138
Fax: 86-592-2388130

China - Zhuhai
Tel: 86-756-3210040
Fax: 86-756-3210049

ASIA/PACIFIC

India - Bangalore
Tel: 91-80-3090-4444
Fax: 91-80-3090-4123

India - New Delhi
Tel: 91-11-4160-8631
Fax: 91-11-4160-8632

India - Pune
Tel: 91-20-2566-1512
Fax: 91-20-2566-1513

Japan - Osaka
Tel: 81-6-6152-7160
Fax: 81-6-6152-9310

Japan - Tokyo
Tel: 81-3-6880-3770
Fax: 81-3-6880-3771

Korea - Daegu
Tel: 82-53-744-4301
Fax: 82-53-744-4302

Korea - Seoul
Tel: 82-2-554-7200
Fax: 82-2-558-5932 or
82-2-558-5934

Malaysia - Kuala Lumpur
Tel: 60-3-6201-9857
Fax: 60-3-6201-9859

Malaysia - Penang
Tel: 60-4-227-8870
Fax: 60-4-227-4068

Philippines - Manila
Tel: 63-2-634-9065
Fax: 63-2-634-9069

Singapore
Tel: 65-6334-8870
Fax: 65-6334-8850

Taiwan - Hsin Chu
Tel: 886-3-5778-366
Fax: 886-3-5770-955

Taiwan - Kaohsiung
Tel: 886-7-213-7828
Fax: 886-7-330-9305

Taiwan - Taipei
Tel: 886-2-2508-8600
Fax: 886-2-2508-0102

Thailand - Bangkok
Tel: 66-2-694-1351
Fax: 66-2-694-1350

EUROPE

Austria - Wels
Tel: 43-7242-2244-39
Fax: 43-7242-2244-393

Denmark - Copenhagen
Tel: 45-4450-2828
Fax: 45-4485-2829

France - Paris
Tel: 33-1-69-53-63-20
Fax: 33-1-69-30-90-79

Germany - Munich
Tel: 49-89-627-144-0
Fax: 49-89-627-144-44

Italy - Milan
Tel: 39-0331-742611
Fax: 39-0331-466781

Netherlands - Drunen
Tel: 31-416-690399
Fax: 31-416-690340

Spain - Madrid
Tel: 34-91-708-08-90
Fax: 34-91-708-08-91

UK - Wokingham
Tel: 44-118-921-5869
Fax: 44-118-921-5820

11/29/12

Компания «Life Electronics» занимается поставками электронных компонентов импортного и отечественного производства от производителей и со складов крупных дистрибьюторов Европы, Америки и Азии.

С конца 2013 года компания активно расширяет линейку поставок компонентов по направлению коаксиальный кабель, кварцевые генераторы и конденсаторы (керамические, пленочные, электролитические), за счёт заключения дистрибьюторских договоров

Мы предлагаем:

- Конкурентоспособные цены и скидки постоянным клиентам.
- Специальные условия для постоянных клиентов.
- Подбор аналогов.
- Поставку компонентов в любых объемах, удовлетворяющих вашим потребностям.
- Приемлемые сроки поставки, возможна ускоренная поставка.
- Доставку товара в любую точку России и стран СНГ.
- Комплексную поставку.
- Работу по проектам и поставку образцов.
- Формирование склада под заказчика.
- Сертификаты соответствия на поставляемую продукцию (по желанию клиента).
- Тестирование поставляемой продукции.
- Поставку компонентов, требующих военную и космическую приемку.
- Входной контроль качества.
- Наличие сертификата ISO.

В составе нашей компании организован Конструкторский отдел, призванный помогать разработчикам, и инженерам.

Конструкторский отдел помогает осуществить:

- Регистрацию проекта у производителя компонентов.
- Техническую поддержку проекта.
- Защиту от снятия компонента с производства.
- Оценку стоимости проекта по компонентам.
- Изготовление тестовой платы монтаж и пусконаладочные работы.



Тел: +7 (812) 336 43 04 (многоканальный)

Email: org@lifeelectronics.ru