

# HDSP-815E/816E/815G/816G

## 20 mm (0.8 inch) General Purpose Seven Segment Displays

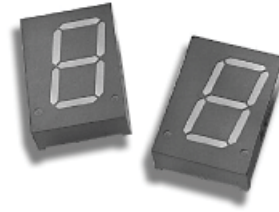

## Data Sheet



### Description

These 20 mm (0.8 inch) displays use industry standard size and pin-out. The devices are available as either common anode or common cathode. Available in either red or green colors, these gray-faced displays are suitable for indoor use.

No color binning is offered for these parts.

These parts are subjected to Outgoing Quality Assurance (OQA) inspection with AQL of 0.065% for functional and visual/cosmetic rejects.

### Devices

HER HDSP-	Green HDSP-	Description
815E	815G	Common Anode Right Hand Decimal
816E	816G	Common Cathode Right Hand Decimal

### Features

- Industry standard size
- Industry standard pin-out  
15.24 mm (0.6 in.) DIP leads on 2.54 mm (0.1 in.) centers
- Choice of colors  
Red, Green
- Mitered font  
Mitered corners on segments
- Gray face paint  
Gray package gives optimum contrast
- $\pm 50^\circ$  Viewing angle
- Design flexibility  
Common anode or common cathode
- Categorized for luminous intensity

### Applications

- Suitable for indoor use
- Not recommended for industrial applications, i.e., operating temperature requirements exceeding  $85^\circ\text{C}$  or below  $-25^\circ\text{C}$  [1]
- Extreme temperature cycling not recommended [2]

#### Notes:

1. For industrial applications, it is recommended to use HDSP-3901/3903/8601/8603.
2. For details, please contact your local Avago Technologies sales office or an authorized distributor.

## Part Numbering System

5082 - X XX X - X X X XX  
HDSP - X XX X - X X X XX

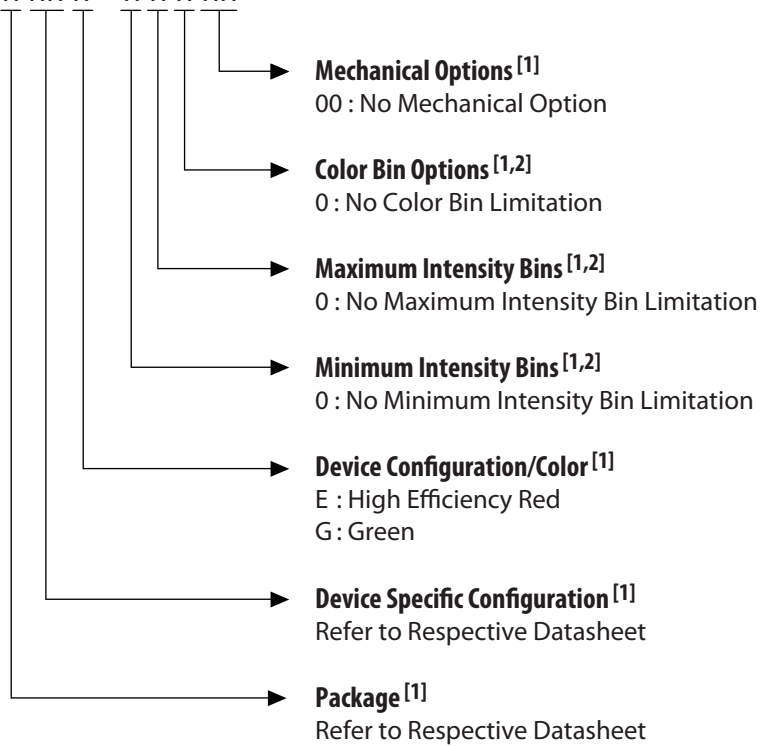

### Notes:

1. For codes not listed in the figure above, please refer to the respective datasheet or contact your nearest Avago representative for details.
2. Bin options refer to shippable bins for a part number. Color and Intensity Bins are typically restricted to 1 bin per tube (exceptions may apply). Please refer to respective datasheet for specific bin limit information.

## Package Dimensions

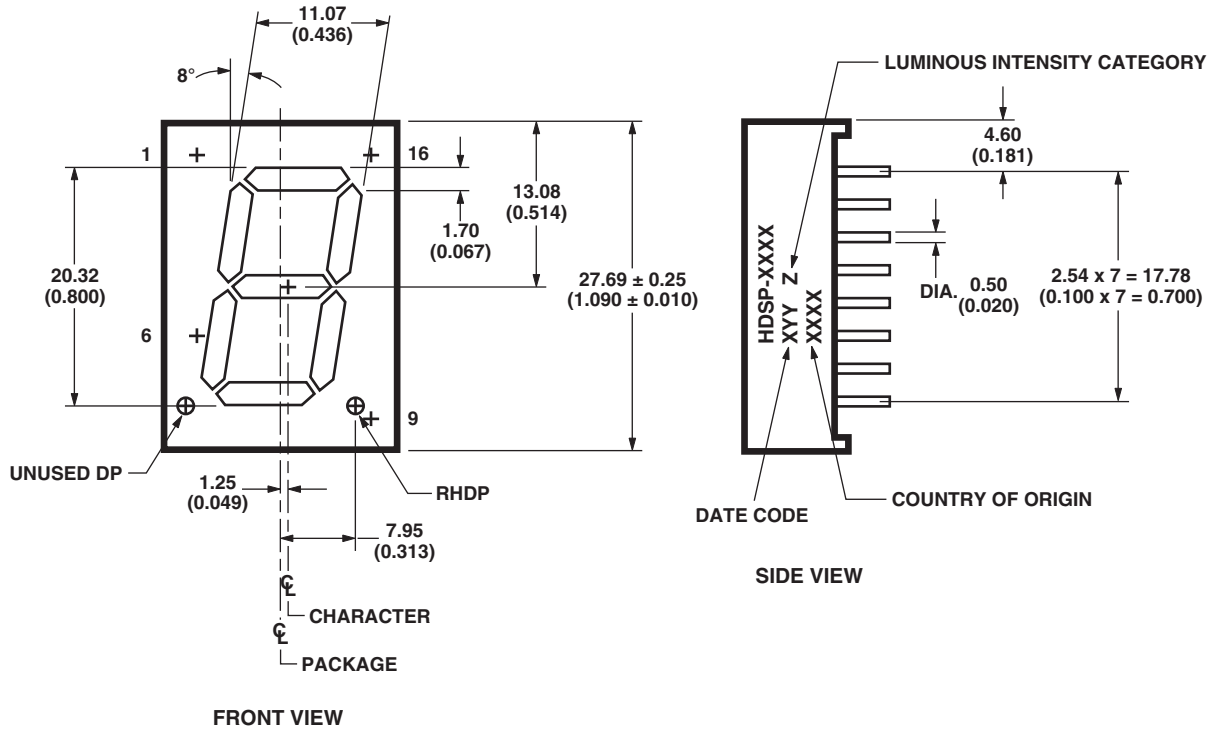

### NOTES:

1. DIMENSIONS IN MILLIMETERS AND (INCHES).
2. TOLERANCE IS 0.25 mm (0.010 INCH) UNLESS OTHERWISE STATED.

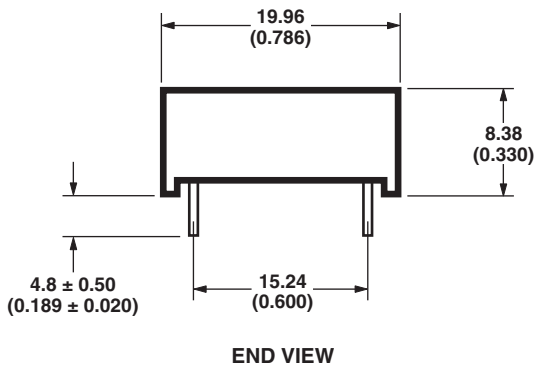

## Internal Circuit Diagram

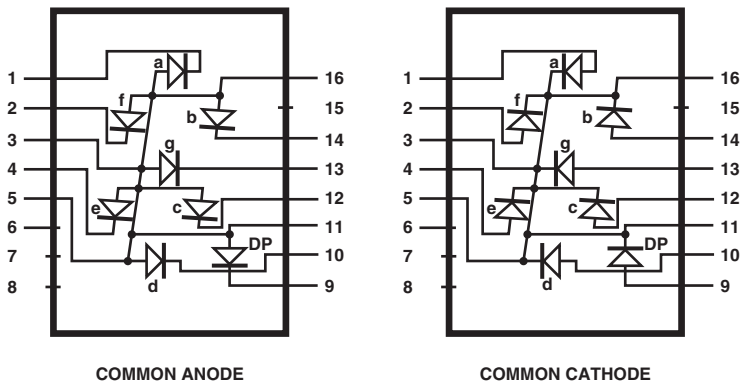

COMMON ANODE		COMMON CATHODE	
PIN	FUNCTION	PIN	FUNCTION
1	CATHODE A	1	ANODE A
2	CATHODE F	2	ANODE F
3	COMMON ANODE	3	COMMON CATHODE
4	CATHODE E	4	ANODE E
5	COMMON ANODE	5	COMMON CATHODE
6	NO CONNECTION	6	NO CONNECTION
7	NO PIN	7	NO PIN
8	NO PIN	8	NO PIN
9	CATHODE RHDP	9	ANODE RHDP
10	CATHODE D	10	ANODE D
11	COMMON ANODE	11	COMMON CATHODE
12	CATHODE C	12	ANODE C
13	CATHODE G	13	ANODE G
14	CATHODE B	14	ANODE B
15	NO PIN	15	NO PIN
16	COMMON ANODE	16	COMMON CATHODE

## Absolute Maximum Ratings at $T_A = 25^\circ\text{C}$

Parameter	High Efficiency Red	Green	Units
	HDSP-815E HDSP-816E	HDSP-815G HDSP-816G	
Average Power per Segment or DP	62.5	65	mW
Peak Forward Current per Segment or DP (1/10 Duty Cycle, 0.1 ms Pulse Width)	100	90	mA
DC Forward Current per Segment or DP <sup>[1]</sup>	25	25	mA
Reverse Voltage per Segment or DP	3	3	V
Operating Temperature	-25 to +85	-25 to +85	$^\circ\text{C}$
Storage Temperature	-25 to +85	-25 to +85	$^\circ\text{C}$
Wave Soldering Temperature for 3 Seconds <sup>[2]</sup> (1.6 mm [0.063 in.] below Body)	250	250	$^\circ\text{C}$

Notes:

- Derate above  $25^\circ\text{C}$  at  $0.33\text{ mA}/^\circ\text{C}$ .
- Not recommended to be soldered more than 2 times. Minimum interval between solderings is 15 minutes. Total soldering time not to exceed 5 seconds.

## Optical/Electrical Characteristics at $T_A = 25^\circ\text{C}$

### High Efficiency Red

Devices HDSP-	Parameter	Symbol	Min.	Typ.	Max.	Units	Test Conditions
815E 816E	Luminous Intensity/Segment (Segment Average) <sup>[1,2]</sup>	$I_V$	2.3	4.8		mcd	$I_F = 20\text{ mA}$
	Forward Voltage/Segment or DP	$V_F$		2.1	3.0	V	$I_F = 20\text{ mA}$
	Peak Wavelength	$\lambda_{\text{PEAK}}$		635		nm	
	Dominant Wavelength <sup>[3]</sup>	$\lambda_d$		626		nm	
	Reverse Voltage/Segment or DP <sup>[4]</sup>	$V_R$	3.0	25		V	$I_R = 100\ \mu\text{A}$
	Temperature Coefficient of $V_F$ / Segment or DP	$\Delta V_F/^\circ\text{C}$		-2		$\text{mV}/^\circ\text{C}$	

### Green

Devices HDSP-	Parameter	Symbol	Min.	Typ.	Max.	Units	Test Conditions
815G 816G	Luminous Intensity/Segment (Segment Average) <sup>[1,2]</sup>	$I_V$	1.5	3.3		mcd	$I_F = 20\text{ mA}$
	Forward Voltage/Segment or DP	$V_F$		2.1	2.6	V	$I_F = 20\text{ mA}$
	Peak Wavelength	$\lambda_{\text{PEAK}}$		566		nm	
	Dominant Wavelength <sup>[3]</sup>	$\lambda_d$		571		nm	
	Reverse Voltage/Segment or DP <sup>[4]</sup>	$V_R$	3.0	50		V	$I_R = 100\ \mu\text{A}$
	Temperature Coefficient of $V_F$ / Segment or DP	$\Delta V_F/^\circ\text{C}$		-2		$\text{mV}/^\circ\text{C}$	

Notes:

- Case temperature of the device immediately prior to the intensity measurement is  $25^\circ\text{C}$ .
- The digits are categorized for luminous intensity. The intensity category is designated by a letter on the side of the package.
- The dominant wavelength,  $\lambda_d$ , is derived from the CIE chromaticity diagram and represents the single wavelength which defines the color of the device.
- Typical specification for reference only. Do not exceed absolute maximum ratings.

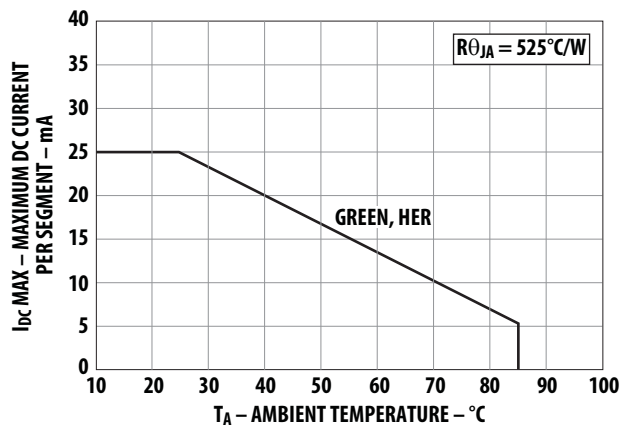

Figure 1. Maximum allowable DC current vs. ambient temperature.

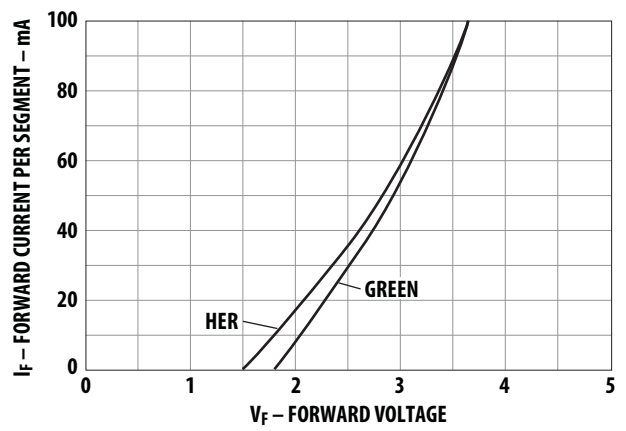

Figure 2. Forward current vs. forward voltage.

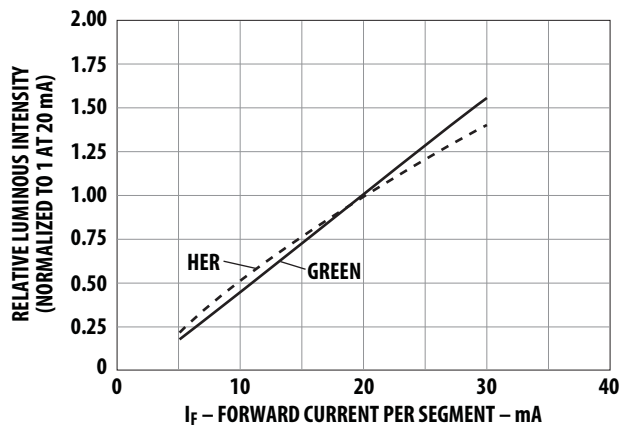

Figure 3. Relative luminous intensity vs. DC forward current.

## Intensity Bin Limits (mcd at 20 mA)

### HER/Green

Bin Name	Green		HER	
	Min. <sup>[1]</sup>	Max. <sup>[1]</sup>	Min. <sup>[1]</sup>	Max. <sup>[1]</sup>
N	NA	NA	5.31	7.57
P	7.57	10.78	7.57	10.78
Q	10.78	15.10	10.78	15.10
R	15.10	21.58	NA	NA

Note:

1. All categories are established for classification of products. Products may not be available in all categories. Please contact your Avago representative for further clarification/information.

### Color Categories

Color	Bin	Dominant Wavelength (nm)	
		Min.	Max.
Green	1	569.00	572.00
	2	572.00	575.00

## Contrast Enhancement

For information on contrast enhancement, please see Application Note 1015.

## Soldering/Cleaning

Cleaning agents from the ketone family (acetone, methyl ethyl ketone, etc.) and from the chlorinated hydrocarbon family (methylene chloride, trichloroethylene, carbon tetrachloride, etc.) are not recommended for cleaning LED parts. All of these various solvents attack or dissolve the encapsulating epoxies used to form the package of plastic LED parts.

For information on soldering LEDs please refer to Application Note 1027.

## Device Reliability

For reliability information, please see the reliability data sheet 20 mm (0.8 inch) General Purpose Seven Segment Display.

For product information and a complete list of distributors, please go to our web site: [www.avagotech.com](http://www.avagotech.com)

Avago, Avago Technologies, and the A logo are trademarks of Avago Technologies in the United States and other countries. Data subject to change. Copyright © 2005-2012 Avago Technologies. All rights reserved. Obsoletes 5988-7999EN AV02-3639EN - June 20, 2012

**Avago**  
TECHNOLOGIES

Компания «Life Electronics» занимается поставками электронных компонентов импортного и отечественного производства от производителей и со складов крупных дистрибьюторов Европы, Америки и Азии.

С конца 2013 года компания активно расширяет линейку поставок компонентов по направлению коаксиальный кабель, кварцевые генераторы и конденсаторы (керамические, пленочные, электролитические), за счёт заключения дистрибьюторских договоров

Мы предлагаем:

- Конкурентоспособные цены и скидки постоянным клиентам.
- Специальные условия для постоянных клиентов.
- Подбор аналогов.
- Поставку компонентов в любых объемах, удовлетворяющих вашим потребностям.
- Приемлемые сроки поставки, возможна ускоренная поставка.
- Доставку товара в любую точку России и стран СНГ.
- Комплексную поставку.
- Работу по проектам и поставку образцов.
- Формирование склада под заказчика.
- Сертификаты соответствия на поставляемую продукцию (по желанию клиента).
- Тестирование поставляемой продукции.
- Поставку компонентов, требующих военную и космическую приемку.
- Входной контроль качества.
- Наличие сертификата ISO.

В составе нашей компании организован Конструкторский отдел, призванный помогать разработчикам, и инженерам.

Конструкторский отдел помогает осуществить:

- Регистрацию проекта у производителя компонентов.
- Техническую поддержку проекта.
- Защиту от снятия компонента с производства.
- Оценку стоимости проекта по компонентам.
- Изготовление тестовой платы монтаж и пусконаладочные работы.



Тел: +7 (812) 336 43 04 (многоканальный)  
Email: [org@lifeelectronics.ru](mailto:org@lifeelectronics.ru)