

Surge Protection Made Simple™ for IEC Applications

IEC Class I Combined Lightning, Current and Surge Arresters for 230/400 Volt, 4-Pole TNS & TT Systems



Description

The Cooper Bussmann® IEC Class I 230 volt, four-pole, modular combined lightning, current and surge arresters feature local, *easyID™* visual indication and optional remote contact signaling. The unique module locking system fixes the protection module to the base part. Modules can be easily replaced without tools by simply depressing the release buttons. Integrated mechanical coding between the base and protection module ensures against installing an incorrect replacement module.

230 Volt models are offered with MCOV ratings of 255 volts.

TNS System Arresters

The features of these four-pole devices are for use in TNS 230/400 volt systems ("4-0" circuit) against surges.

TT System Arrester

Provides a current arresting means between neutral conductor and protective conductor in TT 230/400 volt systems ("3+1" circuit) against surges.

Remote Signaling Contact

The three-pole terminal remote signaling contact versions have a floating changeover contact for use as a break or make contact, according to circuit concept.



BSPS4255TNS(R)
BSPS4255TT(R)



Dimensions - mm

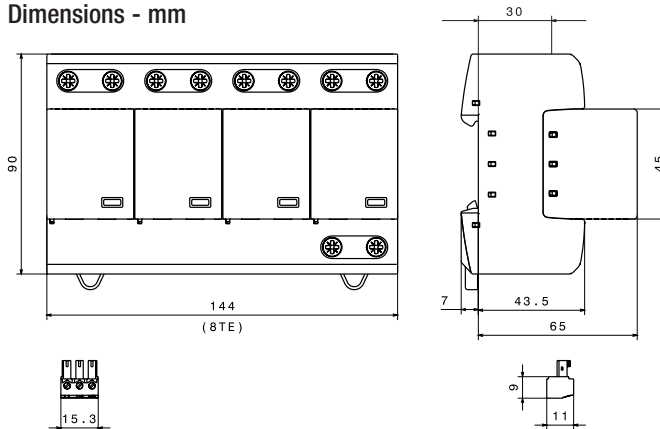

Shown with optional remote contact signaling

Circuit Diagrams

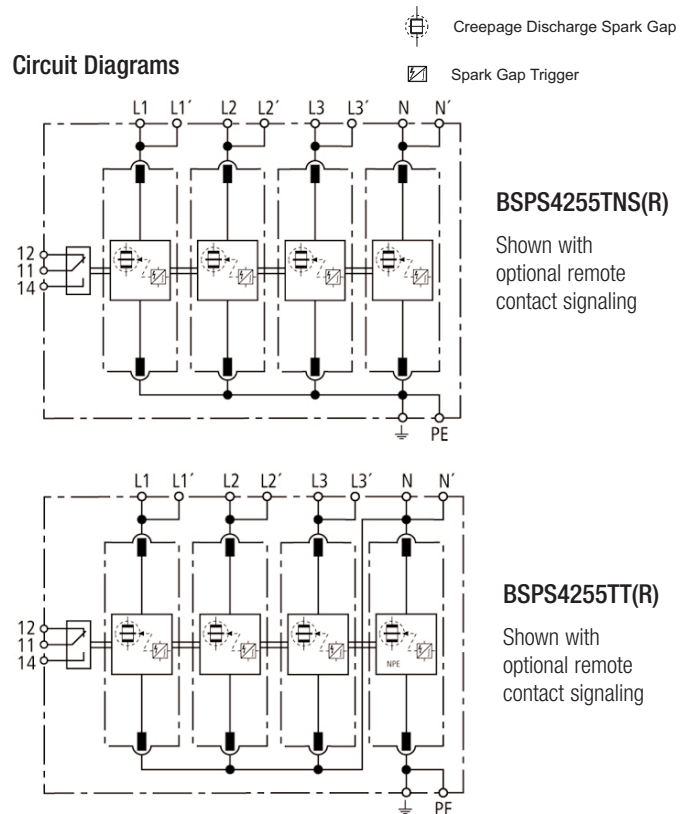

Ordering Information		
System Voltage/Poles	230/400V/4	230/400V/4
Max. Continuous operating AC voltage (MCOV) [U _C]	255V	255V
Catalog Numbers:	Without Remote Signaling	BSPS4255TNS
	With Remote Signaling	BSPS4255TNSR
Replacement Modules (Spark Gap technology):	BPS255IEC	BPS255IEC
	- -	BPS100NPEIEC*
Specifications		
SPD according to EN 61643-11/... IEC 61643-1	Type 1/Class I	
Energy-coordinated protection effect with regard to the terminal equipment	Type 1 + Type 2	
Energy-coordinated protection effect with regard to the terminal equipment (≤ 5m)	Type 1 + Type 2 + Type 3	
Nominal AC voltage [U _N]	230/400V	
Lightning impulse current (10/350 μs) [L1+L2+L3+N-PE] [I _{total}]	100kA	
Specific energy [L1+L2+L3+N-PE] [W/R]	2.50MJ/ohms	
Lightning impulse current (10/350 μs) [L, N-PE] [I _{imp}]	25kA	
TNS system specific energy [L,N-PE] [W/R]	156.25kJ/ohms	
TT system specific energy [L-N]/[N-PE] [W/R]	156.25kJ/ohms/2.50kJ/ohms	
Nominal discharge current (8/20 μs) [I _n]	25/100kA	
Voltage protection level [L-PE]/[N-PE] [U _p]	≤ 1.5kV/≤ 1.5kV	
TNS system follow current extinguishing capability AC [I _{ff}]	50kA rms	
TT system follow current extinguishing capability AC [I _{ff}]	50kA rms/100A rms	
Follow current limitation/Selectivity	No tripping of a 20A gL/gG fuse up to 50kA rms (prosp.)	
Response time [t _A]	≤ 100 ns	
Max. Backup fuse (L) up to I _k ≤ 50kA rms	315A gL/gG	
Max. Backup fuse (L) for I _k > 50kA rms	200A gL/gG	
Max. Backup fuse (L-L')	125A gL/gG	
Temporary overvoltage (TOV) [L-N] [U _T]	440V/5 sec.	
Temporary overvoltage (TOV) [N-PE] [U _T]	1200V/200mS	
TOV characteristics	Withstand	
Operating temperature range [parallel]/[continuity] [T _U]	-40°C to +80°C/-40°C to +60°C	
Operating state/fault indication	green (good)/red (replace)	
Number of ports	1	
Cross-sectional area (L1, L1', L2, L2', L3, L3', N, N', PE, $\frac{\perp}{\perp}$) [min.]	10mm ² solid/flexible	
Cross-sectional area (L1, L2, L3, N, PE) [max.]	50mm ² /1AWG stranded-35mm ² /2AWG flexible	
Cross-sectional area (L1', L2', L3', N', $\frac{\perp}{\perp}$) [max.]	35mm ² /2AWG stranded-25mm ² /4AWG flexible	
Mounting	35mm DIN Rail per EN 60715	
Enclosure material	Thermoplastic, UL 94V0	
Location category	Indoor	
Degree of protection	IP20	
Capacity	8 mods., DIN 43880	
Agency Information	KEMA	
Product Warranty	Five Years**	
Remote Contact Signaling		
Remote Contact Signaling Type	Changeover Contact	
AC Switching Capacity (Volts/Amps)	250V/0.1A	
DC Switching Capacity (Volts/Amps)	250V/0.1A; 125V/0.2A; 75V/0.5A	
Conductor Ratings and Cross-Sectional Area for Remote Contact Signal Terminals	60/75°C Max. 1.5mm ² /14AWG Solid/Flexible	
Ordering Information	Order from Catalog Numbers Above	

* N-PE Surge arrester for location between neutral conductor and protective conductor in TT systems.

** See Cooper Bussmann SPD Limited Warranty Statement (3A1502) for details at www.cooperbussmann.com/surge.

Recommended Cooper Bussmann NH DIN Size Back Up Fuses			
Size	NH Fuse Part Number	Size	NH Fuse Part Number
00	125NHG00B (max L-L)	02	125NHG02B (max L-L)
0	125NHG0B (max L-L)	02	200NHG02B (max L I _k >50kA)
01	125NHG01B (max L-L)	2	315NHG2B (max L ≤50kA)
1	200NHG1B (max L I _k >50kA)	03	315NHG03B (max L ≤50kA)

The only controlled copy of this Data Sheet is the electronic read-only version located on the Cooper Bussmann Network Drive. All other copies of this document are by definition uncontrolled. This bulletin is intended to clearly present comprehensive product data and provide technical information that will help the end user with design applications. Cooper Bussmann reserves the right, without notice, to change design or construction of any products and to discontinue or limit distribution of any products. Cooper Bussmann also reserves the right to change or update, without notice, any technical information contained in this bulletin. Once a product has been selected, it should be tested by the user in all possible applications.

Компания «Life Electronics» занимается поставками электронных компонентов импортного и отечественного производства от производителей и со складов крупных дистрибьюторов Европы, Америки и Азии.

С конца 2013 года компания активно расширяет линейку поставок компонентов по направлению коаксиальный кабель, кварцевые генераторы и конденсаторы (керамические, пленочные, электролитические), за счёт заключения дистрибьюторских договоров

Мы предлагаем:

- Конкурентоспособные цены и скидки постоянным клиентам.
- Специальные условия для постоянных клиентов.
- Подбор аналогов.
- Поставку компонентов в любых объемах, удовлетворяющих вашим потребностям.
- Приемлемые сроки поставки, возможна ускоренная поставка.
- Доставку товара в любую точку России и стран СНГ.
- Комплексную поставку.
- Работу по проектам и поставку образцов.
- Формирование склада под заказчика.
- Сертификаты соответствия на поставляемую продукцию (по желанию клиента).
- Тестирование поставляемой продукции.
- Поставку компонентов, требующих военную и космическую приемку.
- Входной контроль качества.
- Наличие сертификата ISO.

В составе нашей компании организован Конструкторский отдел, призванный помогать разработчикам, и инженерам.

Конструкторский отдел помогает осуществить:

- Регистрацию проекта у производителя компонентов.
- Техническую поддержку проекта.
- Защиту от снятия компонента с производства.
- Оценку стоимости проекта по компонентам.
- Изготовление тестовой платы монтаж и пусконаладочные работы.



Тел: +7 (812) 336 43 04 (многоканальный)

Email: org@lifeelectronics.ru