



MHR-T SERIES

Miniature High-Temperature AC LVDT

SPECIFICATIONS

- ◆ Operating temperature 392°F [200°C]
- ◆ Small size and low mass core
- ◆ High output signal
- ◆ Stroke ranges from ± 0.025 to ± 1 inch
- ◆ AC operation from 2kHz to 20kHz
- ◆ Stainless steel housing
- ◆ Imperial or metric threaded core

The **MHR-T** Series LVDTs are a variant of the legendary MHR Series. The MHR-T Series provide precision measurements in space restrictive applications at temperatures up to 392°F [200°C] continuous.

With a diameter of just 3/8 inch [9.5mm], and an extremely lightweight core, the MHR-T Series is ideal for applications where excessive core weight could influence the motion; with less inertia, accurate measurements at higher displacement speeds are easier to achieve. The lightweight core also reduces mechanical stresses and helps preserve the structural integrity of the core actuation assembly.

The high output sensitivity resulting from the close electrical coupling between the coil and core provides ample signal for interfacing with practically all signal conditioners and conditioning circuits. The magnetic stainless steel housing provides electromagnetic and electrostatic shielding.

Available in a variety of stroke ranges from ± 0.025 to ± 1 inch, the MHR-T is compatible with the full line of Measurement Specialties LVDT signal conditioners.

Like in most of our LVDTs, the MHR-T windings are vacuum impregnated with a specially formulated, high temperature, flexible resin, and the coil assembly is potted inside its housing with a two-component epoxy. This provides excellent protection against hostile environments such as high humidity, vibration and shock.

FEATURES

- ◆ Compact size
- ◆ 392°F [200°C] continuous operation
- ◆ Lightweight core
- ◆ Shock and vibration tolerant
- ◆ Calibration certificate supplied with each unit

APPLICATIONS

- ◆ High temperature applications
- ◆ Cylinder position feedback
- ◆ Materials testing machines
- ◆ Space restricted installations

PERFORMANCE SPECIFICATIONS

ELECTRICAL SPECIFICATIONS (common)						
Input voltage	3 VRMS sine wave					
Input frequency	2kHz to 20kHz					
Test frequency	2.5kHz (standard)					
ELECTRICAL SPECIFICATIONS @ 10kHz (recommended operation)						
Parameter	MHR-T 025	MHR-T 050	MHR-T 100	MHR-T 250	MHR-T 500	MHR-T 1000
Stroke range	±0.025 [±0.64]	±0.05 [±1.27]	±0.10 [±2.54]	±0.25 [±6.35]	±0.5 [±12.7]	±1 [±25.4]
Sensitivity, V/V/inch [mV/V/mm]	8.10 [319]	3.15 [124]	2.80 [110]	2.07 [81.5]	1.96 [77.2]	0.77 [30.3]
Output at stroke ends, mV/V (*)	202.5	157.5	280	517.5	980	770
Phase shift	+21°	+8°	+5°	+7°	+7°	-1°
Input impedance (PRIMARY)	238Ω	419Ω	400Ω	345Ω	264Ω	155Ω
Output impedance (SECONDARY)	485Ω	154Ω	200Ω	420Ω	810Ω	450Ω
Non-linearity	±% of FR					
@ 50% stroke	0.15	0.15	0.15	0.15	0.15	0.20
@100% stroke (maximum)	0.25	0.25	0.25	0.25	0.25	0.25
@125% stroke	0.25	0.35	0.25	0.35	0.30 (**)	0.50
@150% stroke	0.30	0.50	0.30	0.50 (**)	0.75 (**)	/
Null voltage (max.)	0.5% of FSO					

ELECTRICAL SPECIFICATIONS @ 2.5kHz (standard calibration)						
Parameter	MHR-T 025	MHR-T 050	MHR-T 100	MHR-T 250	MHR-T 500	MHR-T 1000
Stroke range	±0.025 [±0.64]	±0.05 [±1.27]	±0.10 [±2.54]	±0.25 [±6.35]	±0.5 [±12.7]	±1 [±25.4]
Sensitivity, V/V/in [mV/V/mm]	4.36 [172]	2.55 [100]	2.40 [94]	1.73 [68]	1.60 [63]	0.70 [27]
Output at 100% stroke, mV/V (*)	109	127.5	240	432.5	800	700
Phase shift	+58°	+36°	+30°	+33°	+23°	+6°
Input impedance (PRIMARY)	116Ω	141Ω	135Ω	147Ω	145Ω	100Ω
Output impedance (SECONDARY)	286Ω	90Ω	125Ω	268Ω	445Ω	370Ω
Non-linearity	±% of FR					
@ 50% stroke	0.15	0.15	0.15	0.15	0.15	0.20
@100% stroke (maximum)	0.25	0.25	0.25	0.25	0.25	0.25
@125% stroke	0.25	0.35	0.25	0.35	0.30 (**)	0.50
@150% stroke	0.30	0.50	0.30	0.50 (**)	0.75 (**)	/
Null voltage (max)	0.5% of FSO					

ENVIRONMENTAL SPECIFICATIONS & MATERIALS	
Operating temperature	-4°F to +392°F [-20°C to +200°C]
Shock survival	1,000 g (11ms half-sine)
Vibration tolerance	20 g up to 2KHz
Housing material	AISI 400 Series stainless steel
Electrical connection	Six lead-wires, 32 AWG stranded plated Copper, PTFE insulated, 3 foot [1 meter] long
IEC 60529 rating	IP61

Notes:

All values are nominal unless otherwise noted

Electrical specifications are for the test frequency indicated in the table

Dimensions are in inch [mm] unless otherwise noted

FR: Full Range is the stroke range, end to end; FR=2xS for ±S stroke range

FSO (Full Scale Output): Largest absolute value of the outputs measured at the ends of the range

(*) Unit for output at stroke ends is millivolt per volt of excitation (input voltage)

(**) Requires special reduced core length

MHR-T SERIES

Miniature High-Temperature AC LVDT

MECHANICAL SPECIFICATIONS

Parameter	MHR-T 025	MHR-T 050	MHR-T 100	MHR-T 250	MHR-T 500	MHR-T 1000
Body length "A"	0.660 [16.8]	0.815 [20.7]	0.990 [25.1]	1.850 [47.0]	3.300 [83.82]	5.600 [142.2]
Core length "B"	0.400 [10.2]	0.500 [12.7]	0.625 [15.9]	1.125 [28.6]	2.000 [50.8]	3.000 [76.2]
Body weight, oz [g]	0.18 [5]	0.21 [6]	0.21 [6]	0.32 [9]	0.60 [17]	0.92 [26]
Core weight, oz [g]	0.016 [0.5]	0.016 [0.5]	0.025 [0.7]	0.032 [0.9]	0.056 [1.6]	0.088 [2.5]

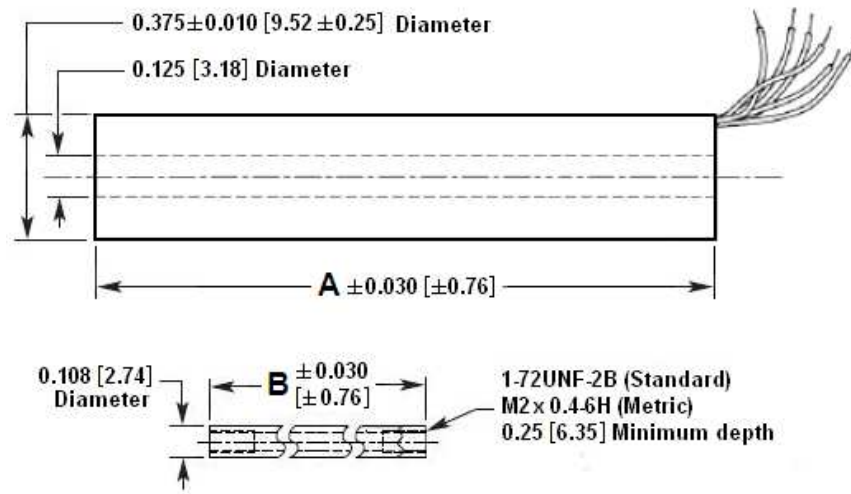

Dimensions are in inch [mm]

WIRING INFORMATION

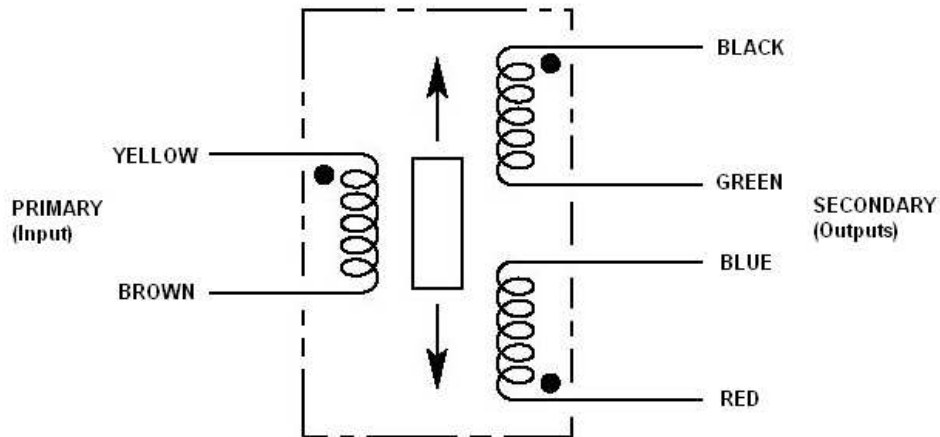

Connect Blue to Green for differential output

MHR-T SERIES

Miniature High-Temperature AC LVDT

ORDERING INFORMATION

Description	Model	Part Number
±0.025 inch LVDT	MHR-T 025	02562407-000
±0.05 inch LVDT	MHR-T 050	02562408-000
±0.10 inch LVDT	MHR-T 100	02562409-000

Description	Model	Part Number
±0.25 inch LVDT	MHR-T 250	02562410-000
±0.5 inch LVDT	MHR-T 500	02562411-000
±1 inch LVDT	MHR-T 1000	02562412-000

OPTIONS AND ACCESSORIES	
Metric threaded core option (use base part numbers from above)	XXXXXXXX-006
Core connecting rod, 6 inches long, 1-72 threads	05282945-006
Core connecting rod, 12 inches long, 1-72 threads	05282945-012
Core connecting rod, 24 inches long, 1-72 threads	05282945-024
Core connecting rod, 36 inches long, 1-72 threads	05282945-036
Core connecting rod, 6 inches long, M2x0.4 metric threads	05282976-006
Core connecting rod, 12 inches long, M2x0.4 metric threads	05282976-012

NORTH AMERICA

Measurement Specialties, Inc.,
a TE Connectivity company
Tel: 800-522-6752
Email: customercare.frm@te.com

EUROPE

Measurement Specialties (Europe), Ltd.,
a TE Connectivity Company
Tel: 800-440-5100
Email: customercare.bevx@te.com

ASIA

Measurement Specialties (China) Ltd.,
a TE Connectivity company
Tel: 0400-820-6015
Email: customercare.shzn@te.com

TE.com/sensorsolutions

Measurement Specialties, Inc., a TE Connectivity company.

Measurement Specialties, TE Connectivity, TE Connectivity (logo) and EVERY CONNECTION COUNTS are trademarks. All other logos, products and/or company names referred to herein might be trademarks of their respective owners.

The information given herein, including drawings, illustrations and schematics which are intended for illustration purposes only, is believed to be reliable. However, TE Connectivity makes no warranties as to its accuracy or completeness and disclaims any liability in connection with its use. TE Connectivity's obligations shall only be as set forth in TE Connectivity's Standard Terms and Conditions of Sale for this product and in no case will TE Connectivity be liable for any incidental, indirect or consequential damages arising out of the sale, resale, use or misuse of the product. Users of TE Connectivity products should make their own evaluation to determine the suitability of each such product for the specific application.

© 2015 TE Connectivity Ltd. family of companies All Rights Reserved.

Компания «Life Electronics» занимается поставками электронных компонентов импортного и отечественного производства от производителей и со складов крупных дистрибьюторов Европы, Америки и Азии.

С конца 2013 года компания активно расширяет линейку поставок компонентов по направлению коаксиальный кабель, кварцевые генераторы и конденсаторы (керамические, пленочные, электролитические), за счёт заключения дистрибьюторских договоров

Мы предлагаем:

- Конкурентоспособные цены и скидки постоянным клиентам.
- Специальные условия для постоянных клиентов.
- Подбор аналогов.
- Поставку компонентов в любых объемах, удовлетворяющих вашим потребностям.
- Приемлемые сроки поставки, возможна ускоренная поставка.
- Доставку товара в любую точку России и стран СНГ.
- Комплексную поставку.
- Работу по проектам и поставку образцов.
- Формирование склада под заказчика.
- Сертификаты соответствия на поставляемую продукцию (по желанию клиента).
- Тестирование поставляемой продукции.
- Поставку компонентов, требующих военную и космическую приемку.
- Входной контроль качества.
- Наличие сертификата ISO.

В составе нашей компании организован Конструкторский отдел, призванный помогать разработчикам, и инженерам.

Конструкторский отдел помогает осуществить:

- Регистрацию проекта у производителя компонентов.
- Техническую поддержку проекта.
- Защиту от снятия компонента с производства.
- Оценку стоимости проекта по компонентам.
- Изготовление тестовой платы монтаж и пусконаладочные работы.



Тел: +7 (812) 336 43 04 (многоканальный)

Email: org@lifeelectronics.ru