

LOC	DIST	REVISIONS					
GP	00	P	LTN	DESCRIPTION	DATE	DWN	APVD
		B		REVISED PER ECO-09-022874	9OCT2009	ZMR	MRS
		C		REVISED PER ECO-10-004036	01MAR2010	CJV	MRS
		D		REVISED PER ECO-11-024172	07DEC2011	TX	AC
		E		REVISED PER ECO-12-014021	05DEC2012	TD	AC

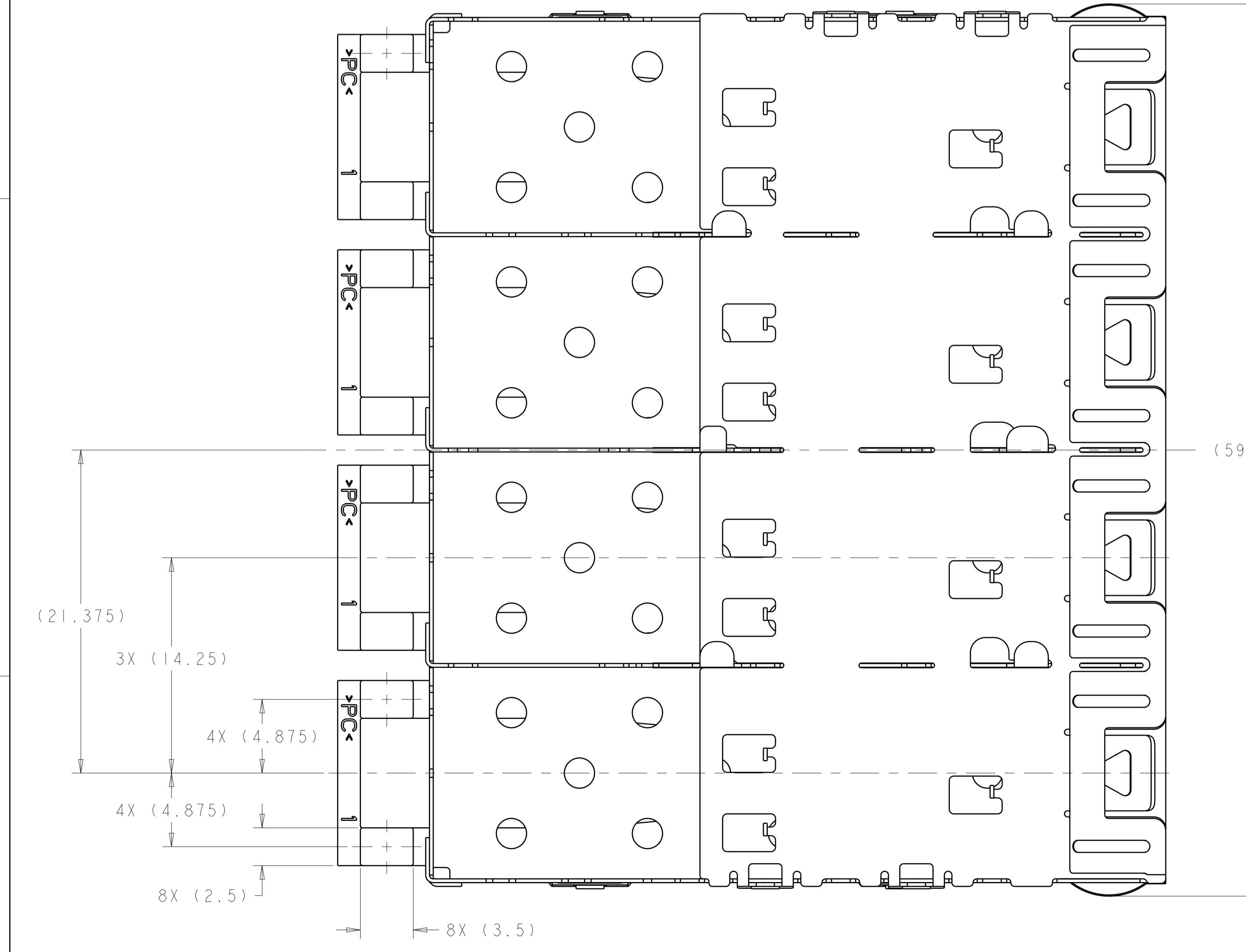

- 1. MATERIAL:
 CAGE ASSEMBLY: 0.25mm THICK NICKEL SILVER ALLOY
 LIGHT PIPE BRACKET: STAINLESS STEEL
 LIGHT PIPE: POLYCARBONATE, CLEAR
- 2. FINISH:
 SPRINGS: MINIMUM OF 0.8um TIN PLATE OVER A MINIMUM OF 0.8um NICKEL UNDERPLATE.
 NON-PLATED EDGES PERMISSIBLE.
- 3. PADS AND VIAS CHASSIS GROUND.
- 4. DATUM AND BASIC DIMENSION ESTABLISHED BY CUSTOMER.
- 5. MATES WITH SFP MSA COMPLIANT TRANSCEIVERS.
- 6. INTERPRETATION OF DATUM REFERENCE FRAME IN ACCORDANCE WITH SECT 4.4.1.1 OF ASME Y14.5M-1994.
- 7. REFERENCE APPLICATION SPEC. 114-13120, HOLE A, FOR RECOMMENDED DRILL HOLE DIAMETER AND PLATING THICKNESS.
- 8. REFERENCE APPLICATION SPEC. 114-13120, HOLE B, FOR RECOMMENDED DRILL HOLE DIAMETER AND PLATING THICKNESS.
- 9. HOLE PATTERN REPEATS FOR EACH PORT. SPACING BETWEEN PORTS IS 14.25mm.
- 10. MINIMUM PC BOARD THICKNESS:
 SINGLE SIDED = 1.50
 DOUBLE SIDED = 2.25
- 11. LIGHT PIPE ASSEMBLY SHIPPED UNASSEMBLED TO CAGE ASSEMBLY. CAGE ASSEMBLY TO BE PRESSED INTO THE PCB PRIOR TO ATTACHING THE LIGHT PIPE ASSEMBLY TO THE CAGE.
- 12. CERTAIN MATING TRANSCEIVERS MAY REQUIRE ADDITIONAL PCB THICKNESS THAT WOULD BE DETERMINED BY THE CUSTOMER.
- 13. PRODUCT COMPLIES WITH SPECIFICATION SFF-8433 IMPROVED PLUGGABLE FROM FACTOR FOR SFP+ GANGED CAGES.

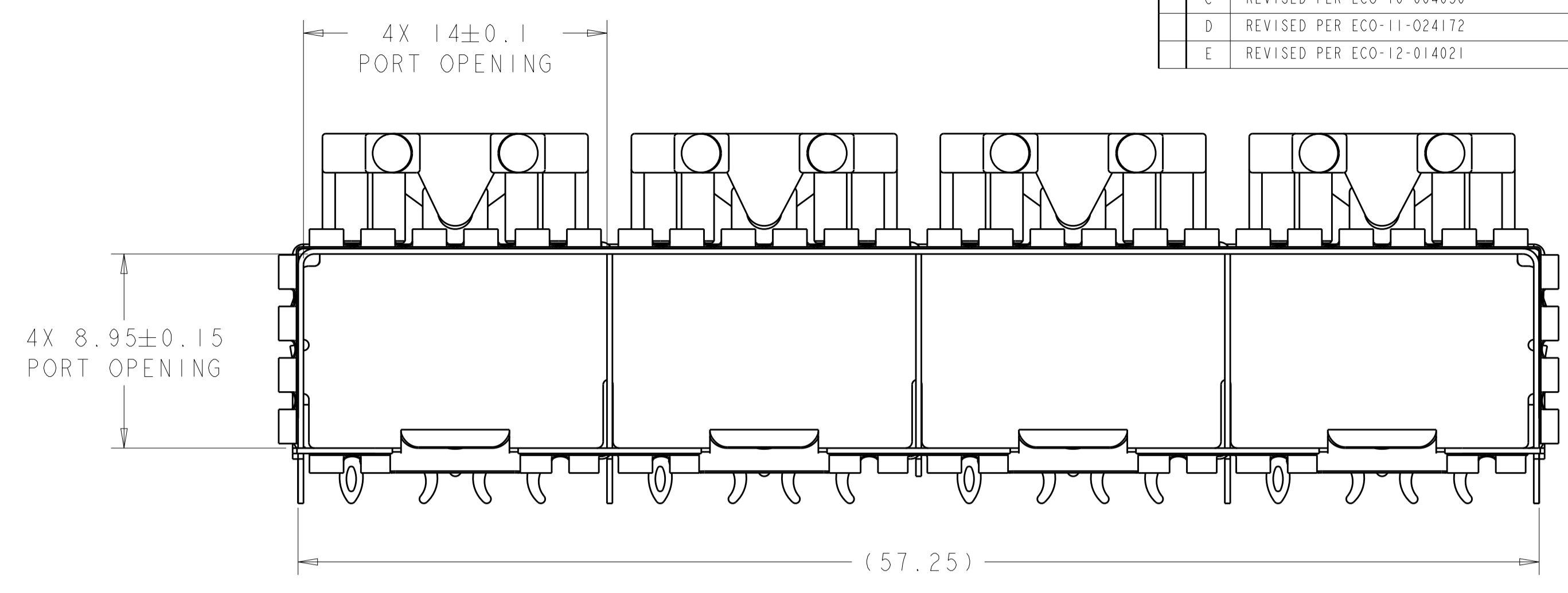
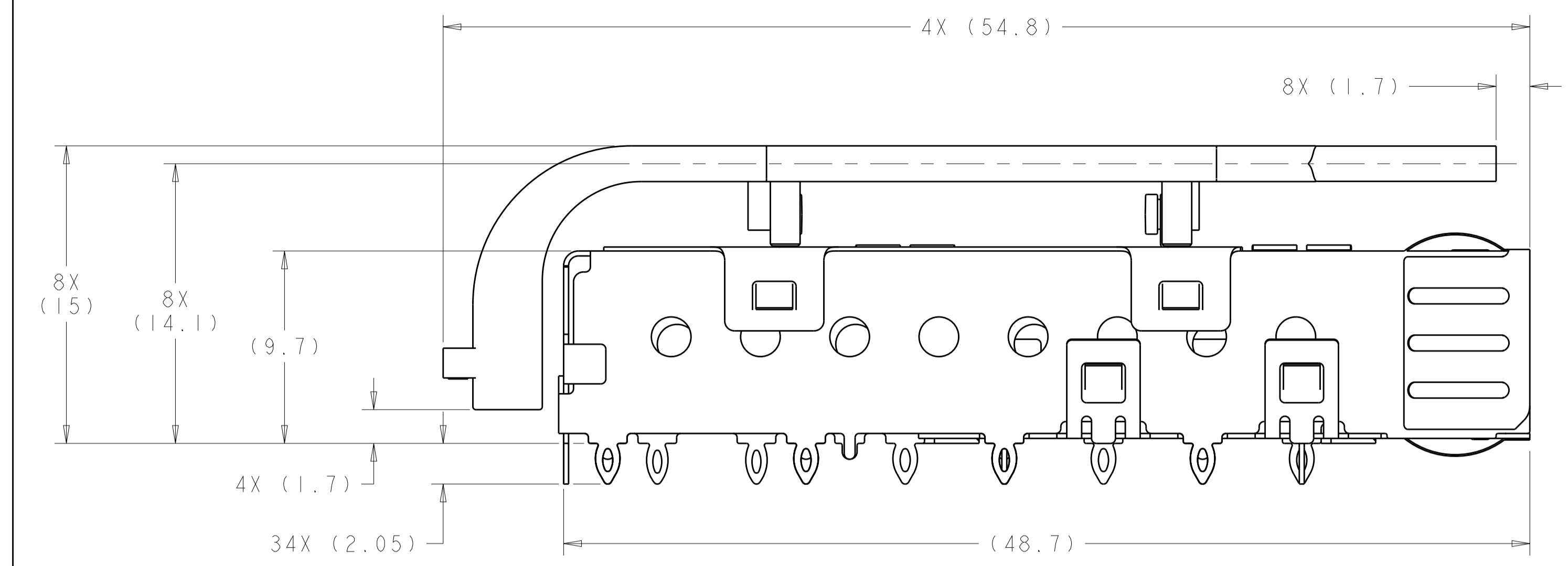
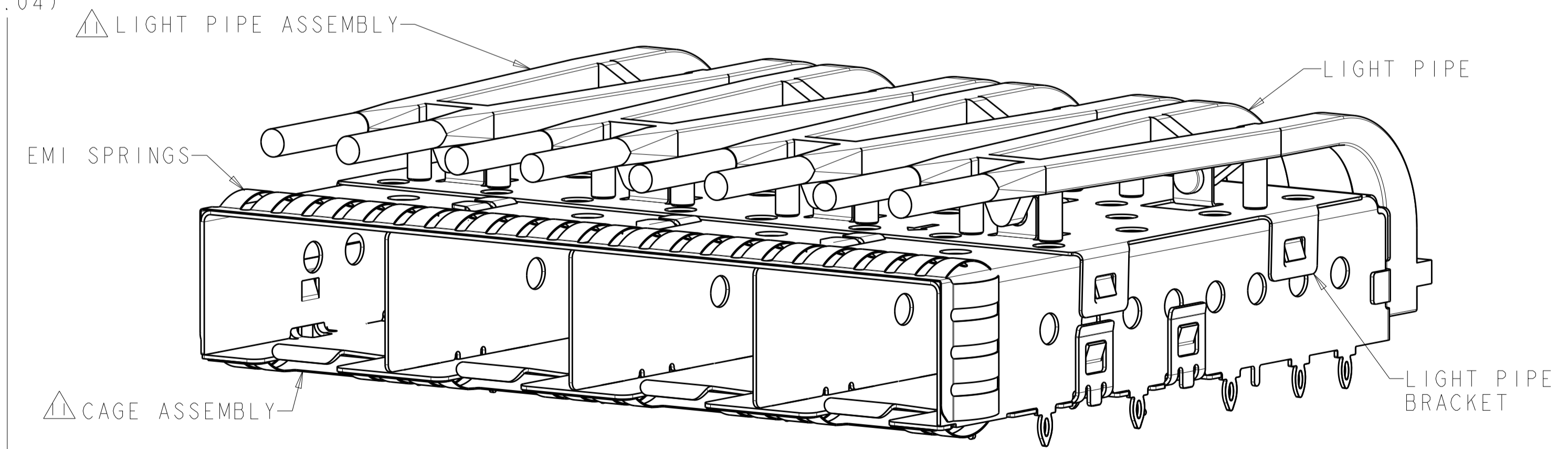

2007178-1
 FINISHED ASSEMBLY
 SCALE 4:1

2007178-1
 PART NUMBER

THIS DRAWING IS A CONTROLLED DOCUMENT.		DWN: M. SCHMITT 21JUN2007	TE Connectivity
DIMENSIONS: mm		CHK: M. SCHMITT 21JUN2007	
TOLERANCES UNLESS OTHERWISE SPECIFIED:		APVD: B. WERTZ 21JUN2007	NAME: SFP+ 1X4 CAGE ASSEMBLY
0 PLC ±0.1	1 PLC ±0.1	PRODUCT SPEC: 108-2364	PRESS FIT, EXTERNAL EMI SPRINGS
2 PLC ±0.1	3 PLC ±0.1	APPLICATION SPEC: 114-13120	WITH LIGHT PIPES
4 PLC ±0.1	ANGLES ±0.1	SIZE: A1	RESTRICTED TO
MATERIAL:	FINISH:	WEIGHT: -	Customer Drawing
		SCALE: 1:1	SHEET 1 OF 4
		REV: E	

LOC	DIST	REV	DATE	BY	APPV
GP	00				

REVISIONS		DATE	BY	APPV
1	SEE SHEET 1			

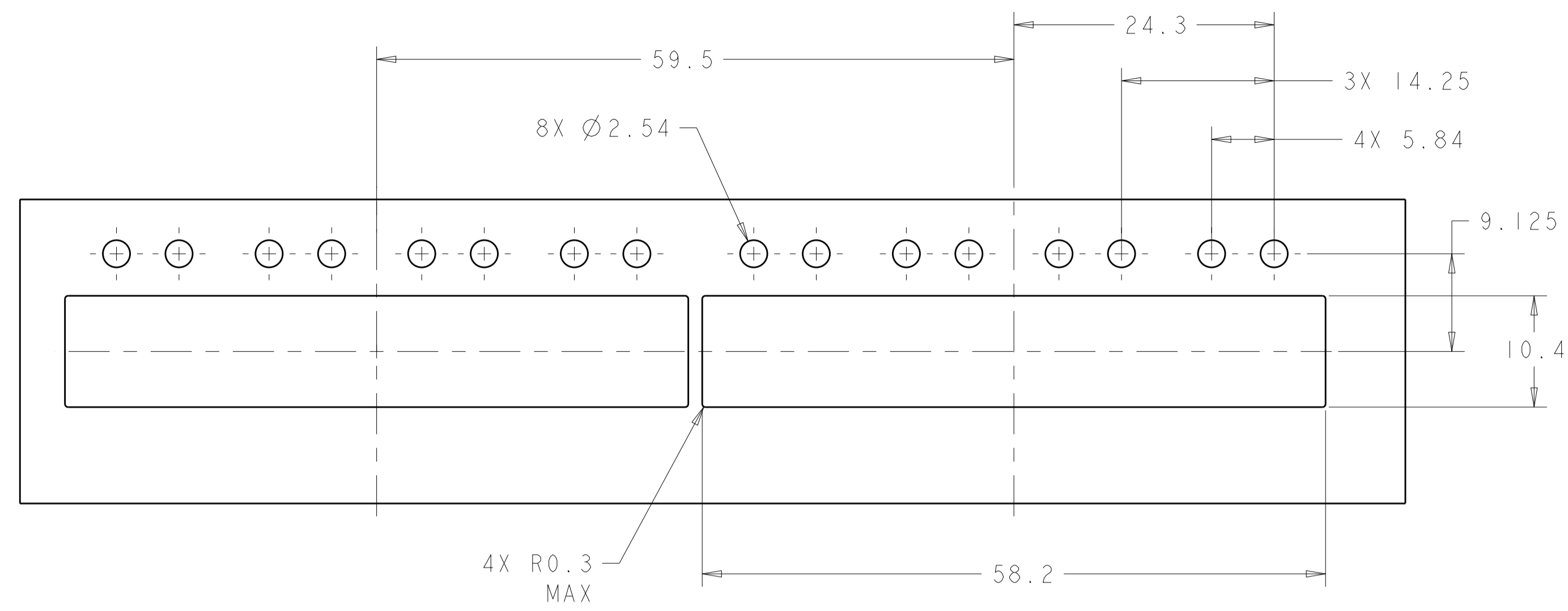

RECOMMENDED BEZEL CUT-OUT
 SINGLE SIDED APPLICATIONS
 SCALE 5:2

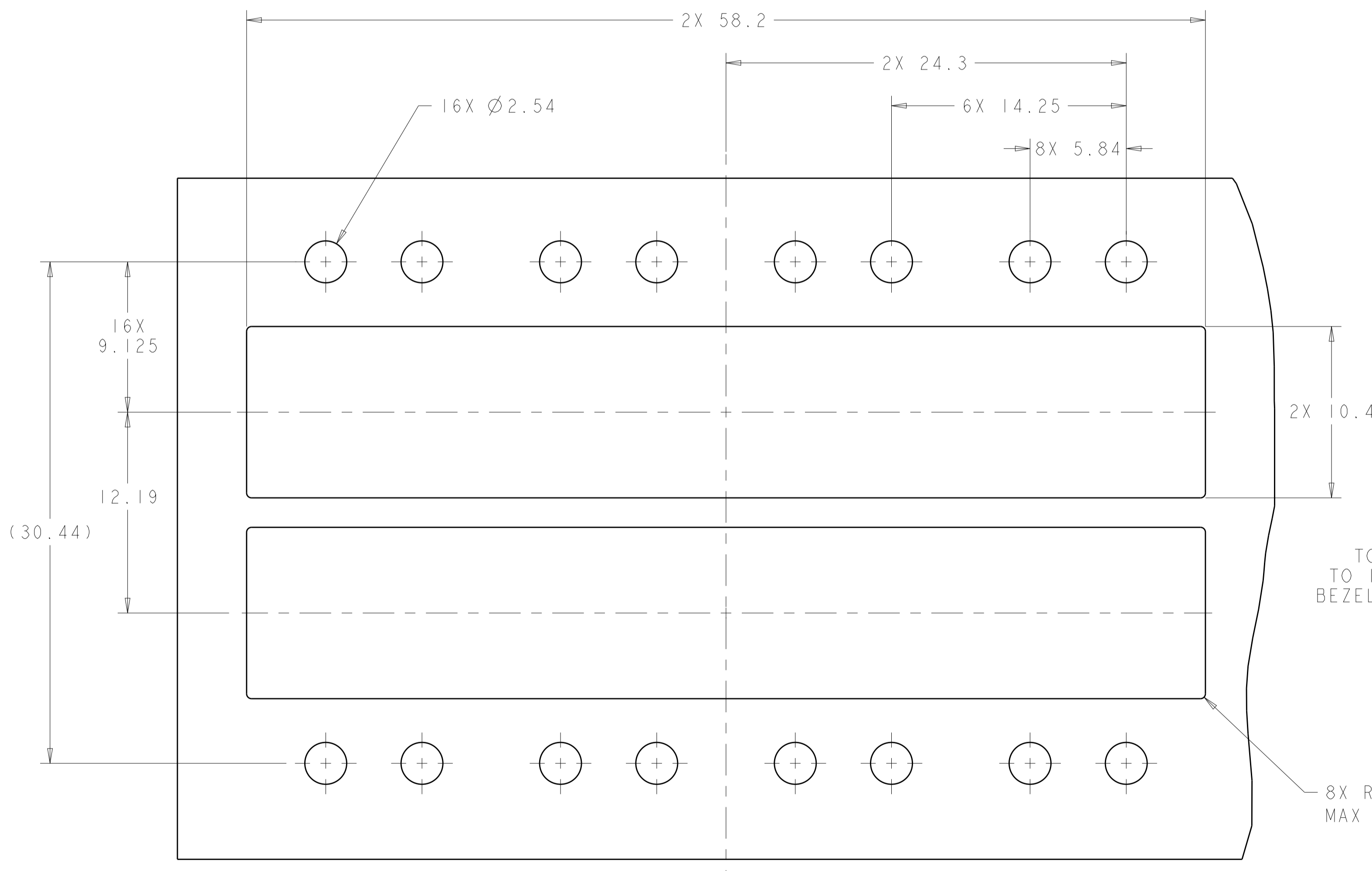

RECOMMENDED BEZEL CUT-OUT
 BELLY TO BELLY APPLICATIONS

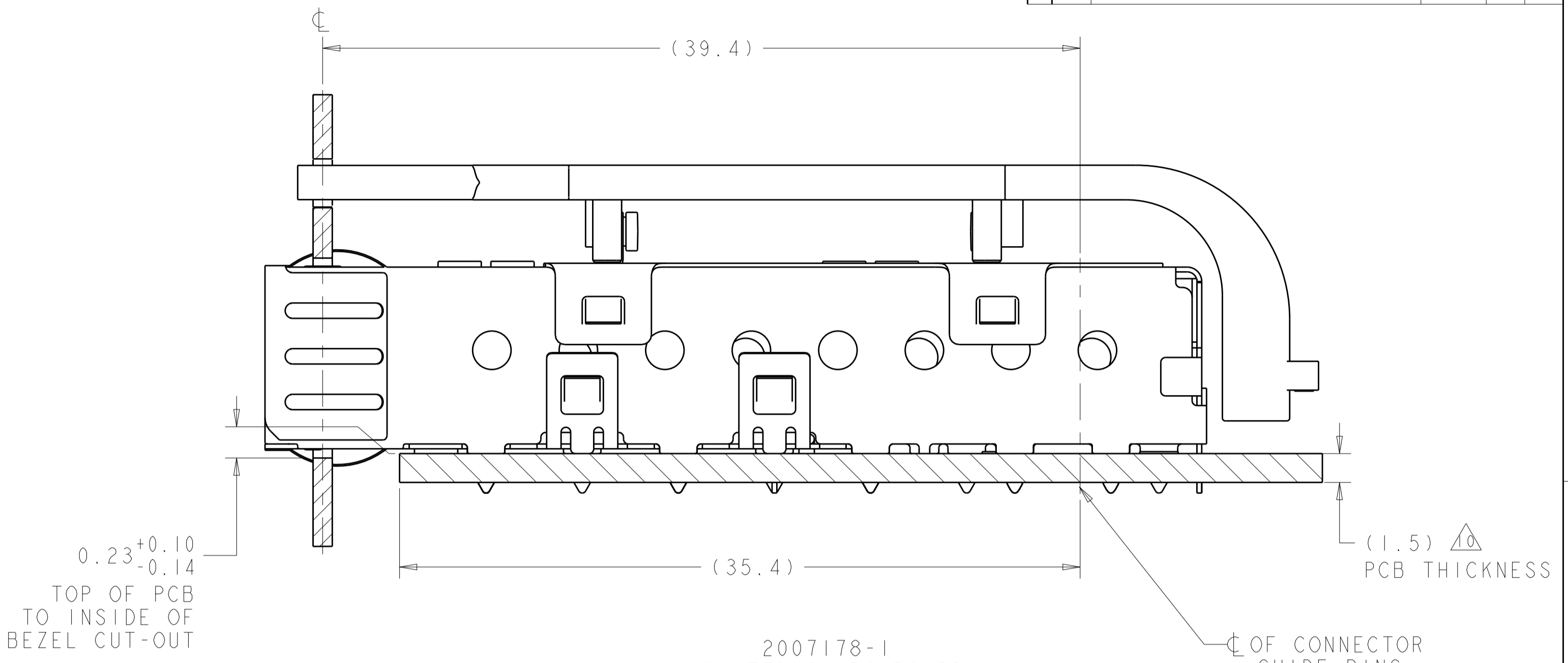

2007178-1
 MOUNTED ON PC BOARD
 SHOWN THRU RECOMMENDED BEZEL

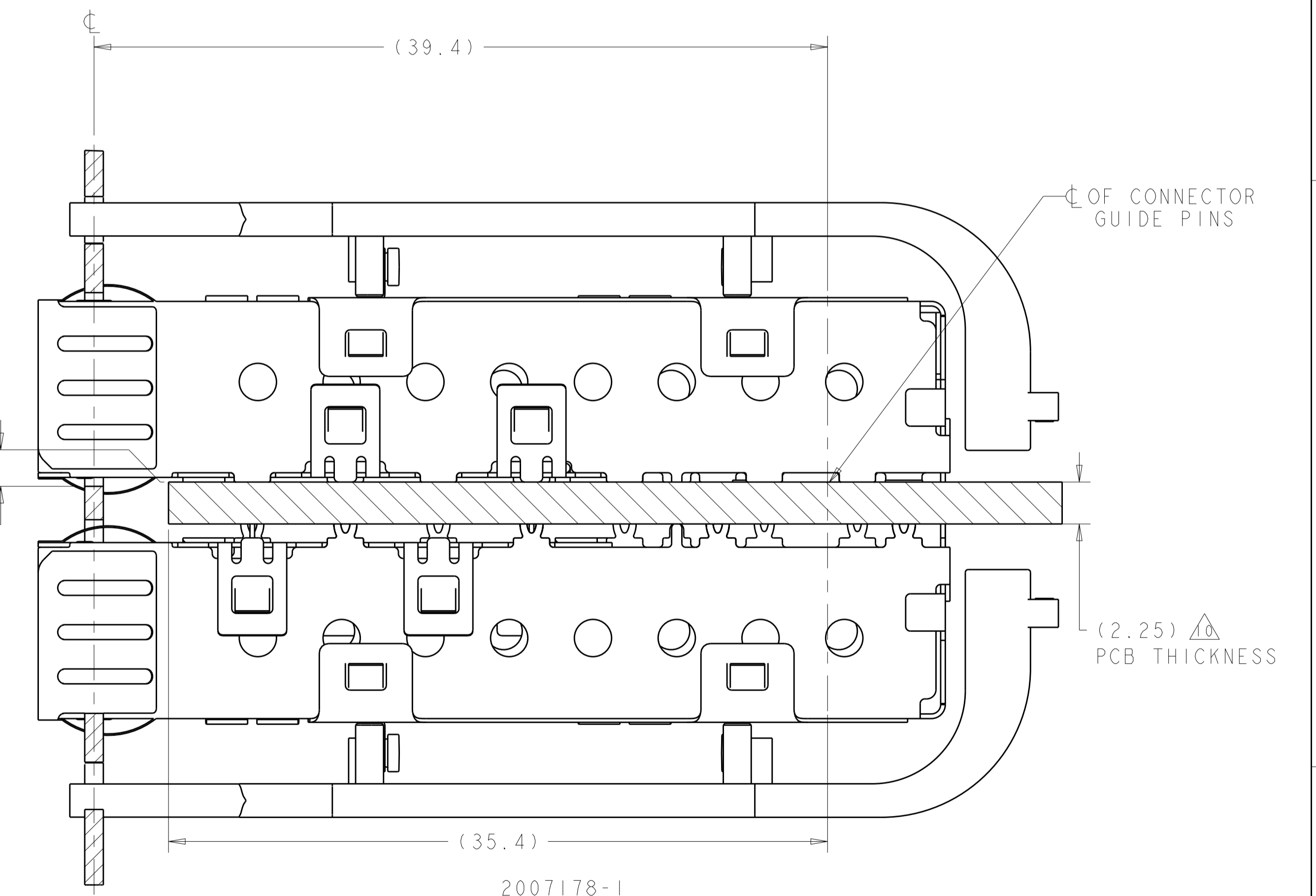

2007178-1
 MOUNTED BELLY TO BELLY ON PC BOARD
 SHOWN THRU RECOMMENDED BEZEL

THIS DRAWING IS A CONTROLLED DOCUMENT.		OWN: M. SCHMITT 21JUN2007	TE Connectivity
DIMENSIONS: mm		CHK: M. SCHMITT 21JUN2007	
TOLERANCES UNLESS OTHERWISE SPECIFIED:		APPV: B. WERTZ 21JUN2007	NAME: SFP+ 1X4 CAGE ASSEMBLY PRESS FIT, EXTERNAL EMI SPRINGS WITH LIGHT PIPES
0 PLC	±0.1	PRODUCT SPEC	SIZE: CAGE CODE DRAWING NO
1 PLC	±0.1	108-2364	RESTRICTED TO
2 PLC	±0.1	APPLICATION SPEC	A100779C=2007178
3 PLC	±0.1	114-13120	SCALE: 1:1 SHEET 2 OF 4 REV E
4 PLC	±0.1	WEIGHT	
ANGLES	±1°	Customer Drawing	
MATERIAL	FINISH		

LOC	DIST	REV	DATE	BY	APPV
GP	00				

REVISIONS			
REV	DATE	BY	APPV
1			

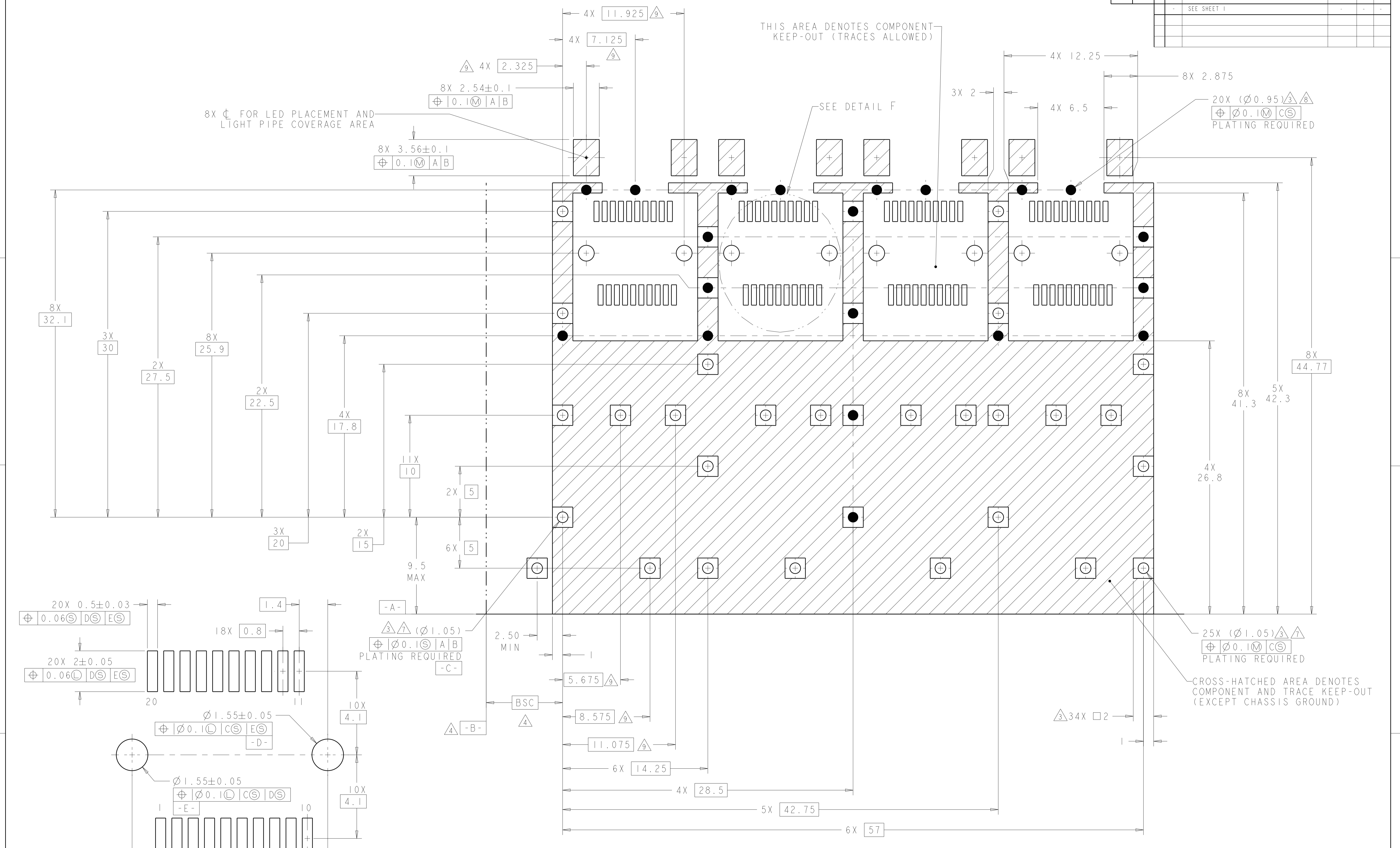

DETAIL F
 RECOMMENDED PT CONNECTOR LAYOUT
 4X INDIVIDUALLY
 SCALE 12:1

RECOMMENDED PCB CONFIGURATION
 WITH KEEP-OUT AREAS
 SINGLE SIDED APPLICATIONS
 SCALE 6:1

THIS DRAWING IS A CONTROLLED DOCUMENT.		OWN: M. SCHMITT 21JUN2007	TE Connectivity NAME: SFP+ 1X4 CAGE ASSEMBLY PRESS FIT, EXTERNAL EMI SPRINGS WITH LIGHT PIPES
DIMENSIONS: mm		CHK: M. SCHMITT 21JUN2007	
TOLERANCES UNLESS OTHERWISE SPECIFIED:		APPV: B. WERTZ 21JUN2007	
0 PLC ±0.1 1 PLC ±0.1 2 PLC ±0.1 3 PLC ±0.1 4 PLC ±0.1 ANGLES ±1°		PRODUCT SPEC: 108-2364 APPLICATION SPEC: 114-13120 WEIGHT: - Customer Drawing	
MATERIAL: -		FINISH: -	SIZE: A1 CAGE CODE: 100779 DRAWING NO: C=2007178 RESTRICTED TO: - SCALE: 1:1 SHEET 3 OF 4 REV E

LOC	DIST	REVISIONS			
GP	00	REV	DATE	BY	APPD
		1	SEE SHEET 1		

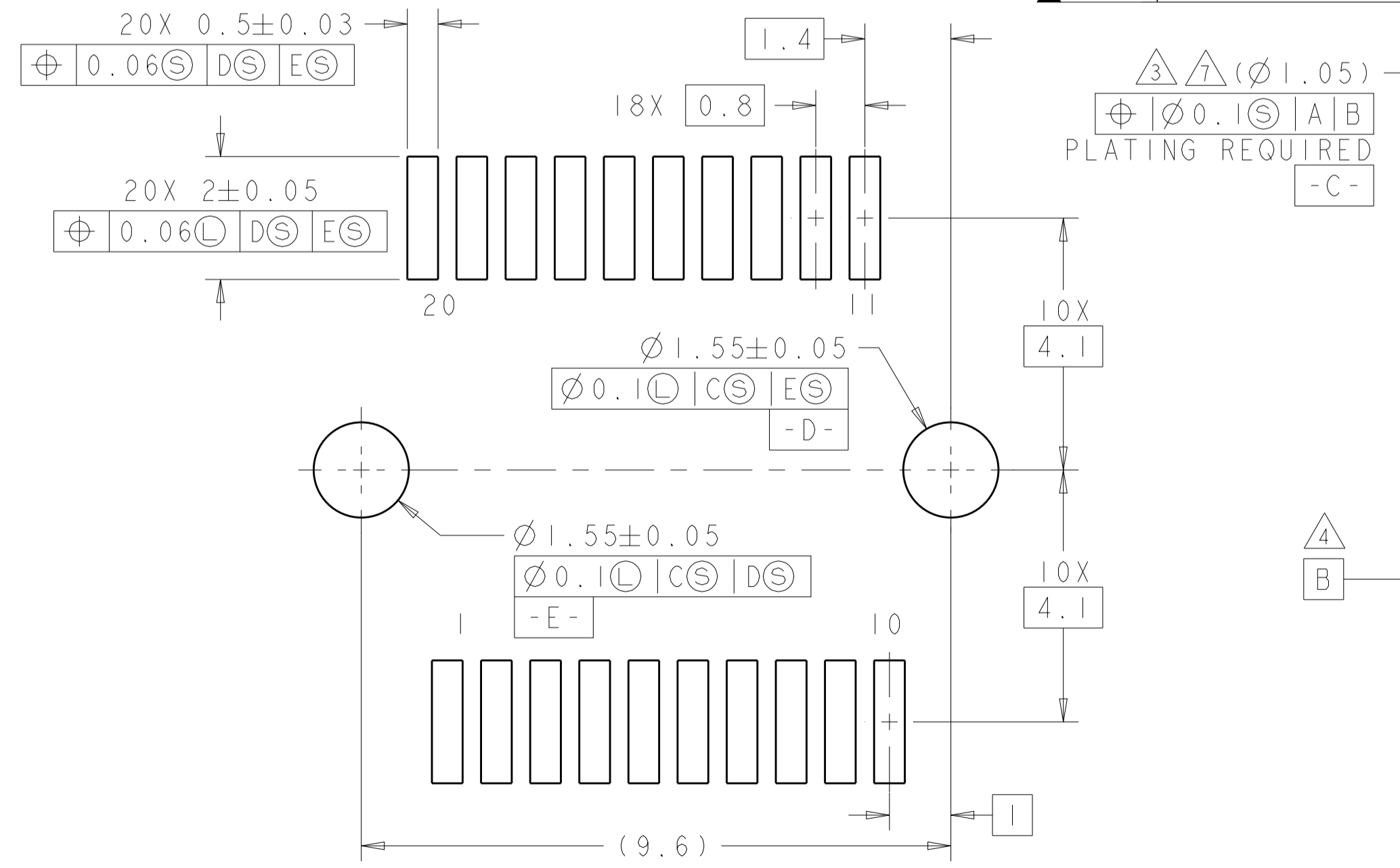
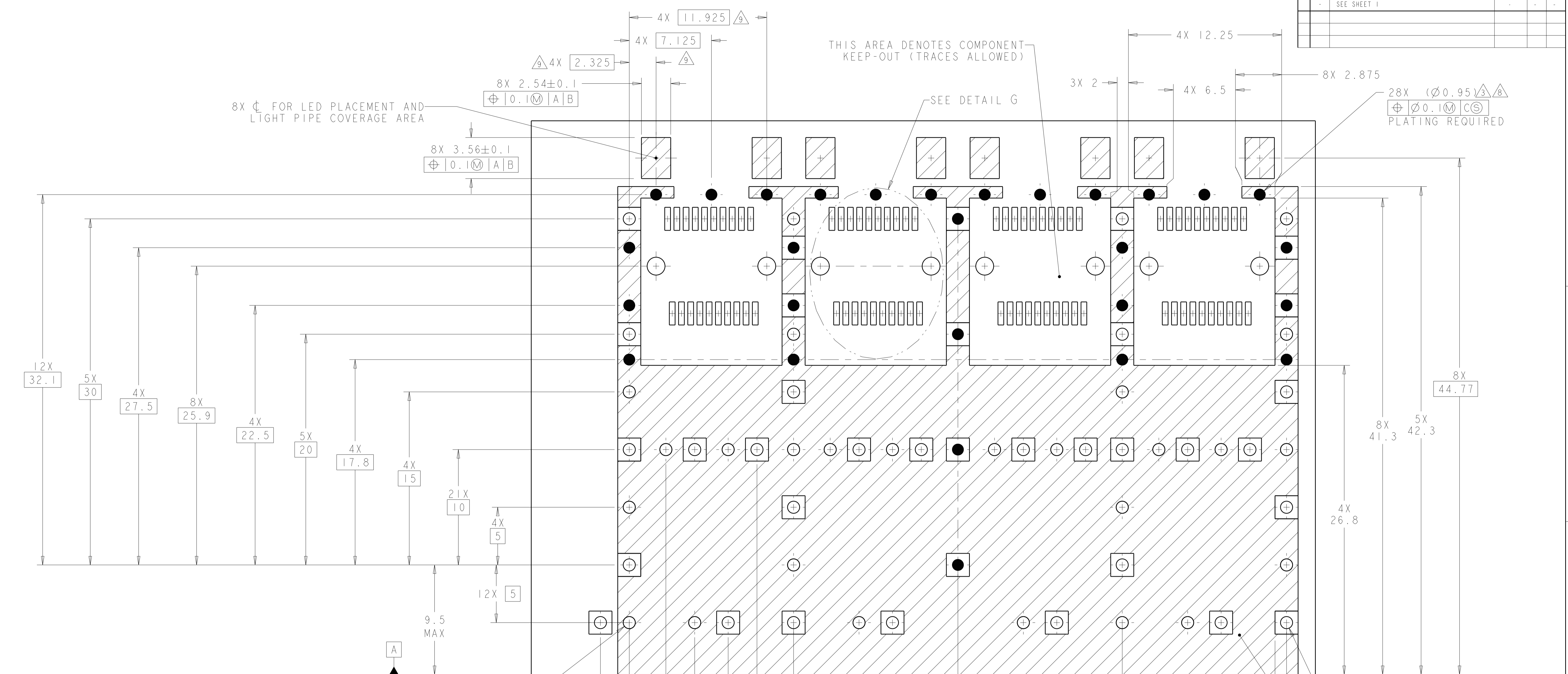

DETAIL G
RECOMMENDED PT CONNECTOR LAYOUT
8X INDIVIDUALLY
SCALE 12:1

THIS AREA DENOTES COMPONENT
KEEP-OUT (TRACES ALLOWED)

SEE DETAIL G

28X (∅0.95) 3/8
∅0.10 C/S
PLATING REQUIRED

51X (∅1.05) 3/8
∅0.10 C/S
PLATING REQUIRED

CROSS-HATCHED AREA DENOTES
COMPONENT AND TRACE KEEP-OUT
(EXCEPT CHASSIS GROUND)

RECOMMENDED PCB CONFIGURATION
WITH KEEP-OUT AREAS
BELLY TO BELLY APPLICATIONS
SCALE 6:1

THIS DRAWING IS A CONTROLLED DOCUMENT.		OWN: M. SCHMITT 21JUN2007	TE Connectivity
DIMENSIONS: mm		CHK: M. SCHMITT 21JUN2007	
TOLERANCES UNLESS OTHERWISE SPECIFIED:		APVD: B. WERTZ 21JUN2007	NAME: SFP+ 1X4 CAGE ASSEMBLY PRESS FIT, EXTERNAL EMI SPRINGS WITH LIGHT PIPES
0 PLC ±0.1		PRODUCT SPEC: 108-2364	
1 PLC ±0.1		APPLICATION SPEC: 114-13120	SIZE: A100779 SCALE: 1:1 SHEET 4 OF 4 REV E
2 PLC ±0.1		WEIGHT: -	
3 PLC ±0.1		Customer Drawing	
4 PLC ±0.1			
ANGLES ±1°			
FINISH: -			

Компания «Life Electronics» занимается поставками электронных компонентов импортного и отечественного производства от производителей и со складов крупных дистрибьюторов Европы, Америки и Азии.

С конца 2013 года компания активно расширяет линейку поставок компонентов по направлению коаксиальный кабель, кварцевые генераторы и конденсаторы (керамические, пленочные, электролитические), за счёт заключения дистрибьюторских договоров

Мы предлагаем:

- Конкурентоспособные цены и скидки постоянным клиентам.
- Специальные условия для постоянных клиентов.
- Подбор аналогов.
- Поставку компонентов в любых объемах, удовлетворяющих вашим потребностям.
- Приемлемые сроки поставки, возможна ускоренная поставка.
- Доставку товара в любую точку России и стран СНГ.
- Комплексную поставку.
- Работу по проектам и поставку образцов.
- Формирование склада под заказчика.
- Сертификаты соответствия на поставляемую продукцию (по желанию клиента).
- Тестирование поставляемой продукции.
- Поставку компонентов, требующих военную и космическую приемку.
- Входной контроль качества.
- Наличие сертификата ISO.

В составе нашей компании организован Конструкторский отдел, призванный помогать разработчикам, и инженерам.

Конструкторский отдел помогает осуществить:

- Регистрацию проекта у производителя компонентов.
- Техническую поддержку проекта.
- Защиту от снятия компонента с производства.
- Оценку стоимости проекта по компонентам.
- Изготовление тестовой платы монтаж и пусконаладочные работы.



Тел: +7 (812) 336 43 04 (многоканальный)

Email: org@lifeelectronics.ru