



Features

- Bidirectional EMI/RFI filtering and line termination with integrated ESD protection
- Provides ESD protection to IEC61000-4-2:
 - $\pm 15\text{kV}$ contact discharge
- TVS working voltage: 5V
- Termination resistors: 40Ω
- Pull-up resistors: $25\text{k}\Omega$
- Typical capacitance per line: 12pF ($V_{IN} = 2.5\text{V}$)
- Protection and termination for six lines + Vcc
- Solid-state technology

Applications

- T-Flash / MicroSD interfaces
- MMC interfaces
- CDMA, GSM, 3G cell phones

Mechanical Characteristics

- 0.40mm, uDFN 16-pin package
- RoHS/WEEE compliance, lead-free finish
- Nominal dimensions: $3.30 \times 1.35 \times 0.50\text{mm}$
- Pitch: 0.4mm
- Pin-lead finish: NiPd

Electrical Schematic

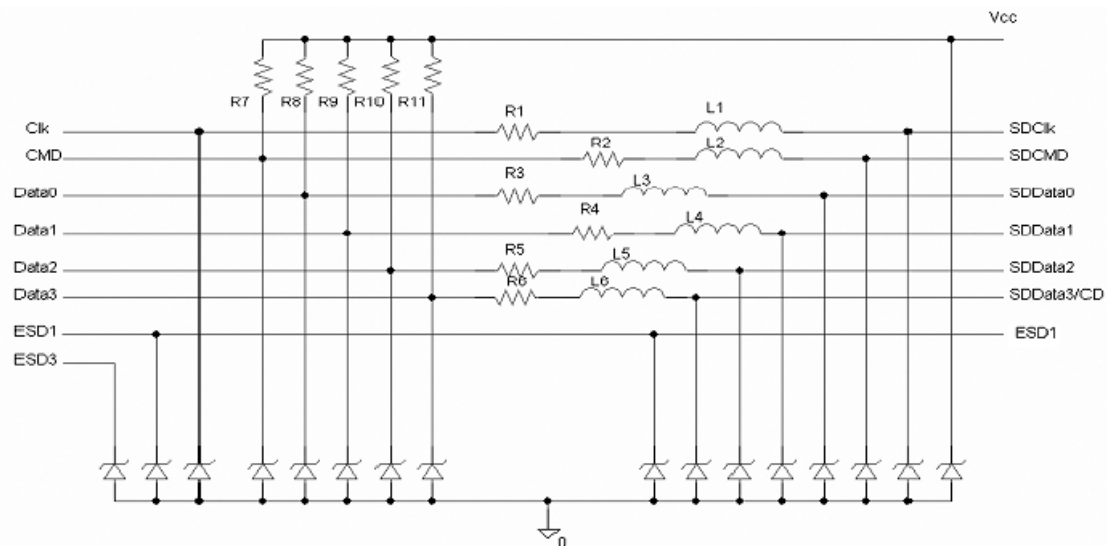

Description

The CM1624 is a combination EMI filter and line termination device with integrated TVS diodes for use on Multimedia Card interfaces. This state-of-the-art device utilizes solid-state, silicon-avalanche technology for superior clamping performance and DC electrical characteristics. The CM1624 has been optimized for protection of T-Flash/MicroSD interfaces in cellular phones and other portable electronics.

The CM1624 consists of six circuits that includes series impedance matching resistors and pull-up resistors as required by the SD specification. TVS diodes are included on each line for ESD protection. An additional TVS diode connection is included for protection of the voltage (Vcc) bus. Termination resistor value of 40Ω is provided on the SDData0, SDData1, SDData2, SDData3, CMD, and CLK lines.

Pull-up resistors of 25kΩ are included on the SDData0, SDData1, SDData2, SDData3 and CMD lines, as well. These may be configured for devices operating in SD or SPI mode. The TVS diodes provide effective suppression of ESD voltages in excess of ±15kV (contact discharge) per IEC 61000-4-2, level 4. The CM1624 is in a 16-pin, RoHS/WEEE compliant, UDFN 16-pin package. It measures 3.30 x 1.35 x 0.50mm. The leads are spaced at a pitch of 0.4mm and are finished with lead-free NiPd.

Package/Pin Information

PACKAGE / PINOUT DIAGRAMS

Top View

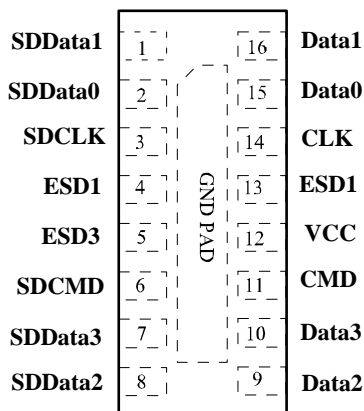

Note:

1) This drawing is not to scale.

CM1624

PIN DESCRIPTIONS

Pin	Name	Description
1	SDData1	Data line #1 input/output with pull-up resistor
2	SDData0	Data line #0 input/output with pull-up resistor
3	SDCLK	Clock line Input/Output
4	ESD1	Single ESD
5	ESD3	Single ESD
6	SDCMD	Command Line Input/Output
7	SDData3	Data line #3 input/output with pull-up resistor
8	SDData2	Data line #2 input/output with pull-up resistor
9	Data2	Data line #2 input/output with pull-up resistor
10	Data3	Data line #3 input/output with pull-up resistor
11	CMD	Command Line Input/Output
12	VCC	Power Supply ESD Protection
13	ESD1	Single ESD
14	CLK	Clock line Input/Output
15	Data0	Data line #0 input/output with pull-up resistor
16	Data1	Data line #1 input/output with pull-up resistor
GND PAD	GND	Ground return to shield

Ordering Information

PART NUMBERING INFORMATION (Note 1)

PIN	PACKAGE	LEAD-FREE FINISH	Part Marking
16	uDFN-16 (0.40mm)	CM1624 -08DE	1624(x) (Note 2)

Note 1: Parts are shipped in Tape and Reel form unless otherwise specified.

Note 2: (x) = single character date code.

Specifications

ABSOLUTE MAXIMUM RATINGS*

PARAMETER	RATING	UNITS
Operating Temperature Range	-40 to +85	°C
Storage Temperature Range	-55 to +150	°C

*Exposure to absolute maximum rating conditions for extended periods may affect device reliability.

ELECTRICAL OPERATING CHARACTERISTICS (SEE NOTE 1)

SYMBOL	PARAMETER	CONDITIONS	MIN	TYP	MAX	UNITS
R_{CH}	Channel Resistance (R1 to R6)		34	40	46	Ω
L_{CH}	Channel Inductance			20		nH
C	Capacitance per Channel	$V_{IN} = 0V; 1MHz; 30mV_{RMS}$	16	20	24	pF
		$V_{IN} = 2.5V; 1MHz; 30mV_{RMS};$		12		pF
R_{UP}	Pull-up Resistance (R7 to R11)		21	25	29	k Ω
I_{LEAK}	Diode Leakage Current per Channel	$V_{IN} = 3V$		0.1	0.5	μA
V_{SIG}	Signal Clamp Voltage Positive Clamp Negative Clamp	$I_{LOAD} = 10mA$ $I_{LOAD} = -10mA$	5.6	6.8	9.0	V
			-1.5	-0.8	-0.4	V
V_{ESD}	ESD Protection - Peak Discharge Voltage at any channel input, in system: a) Contact discharge per IEC 61000-4-2 Standard and b) Air discharge per IEC 61000-4-2 Standard		± 15			kV
			± 15			kV
f_C	Cut-off frequency $Z_{SOURCE} = 50\Omega, Z_{LOAD} = 50\Omega$			300		MHz

Note 1: All parameters specified at $T_A = 25^\circ C$ unless otherwise noted.

Performance Information

Typical Filter Performance (nominal conditions unless specified otherwise, 50Ω Environment)

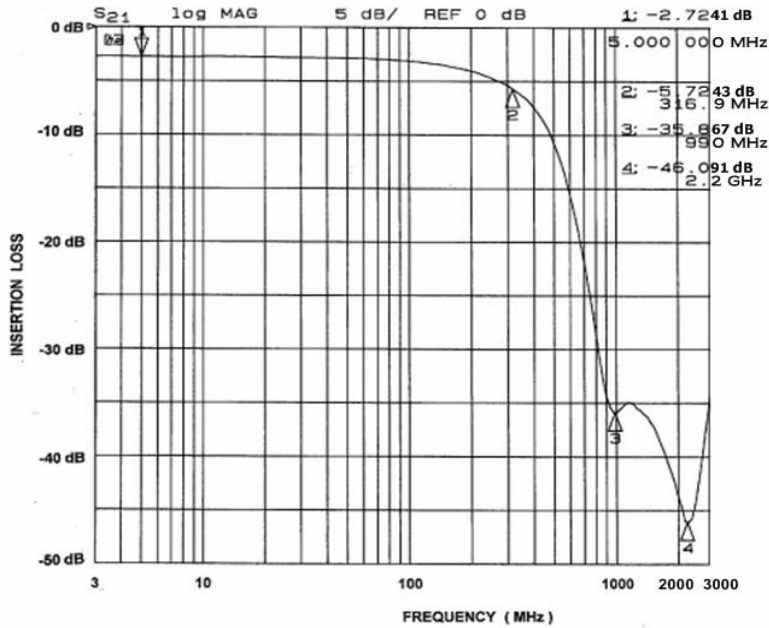

Figure 1. Insertion Loss VS. Frequency (Pins 1 and 16)

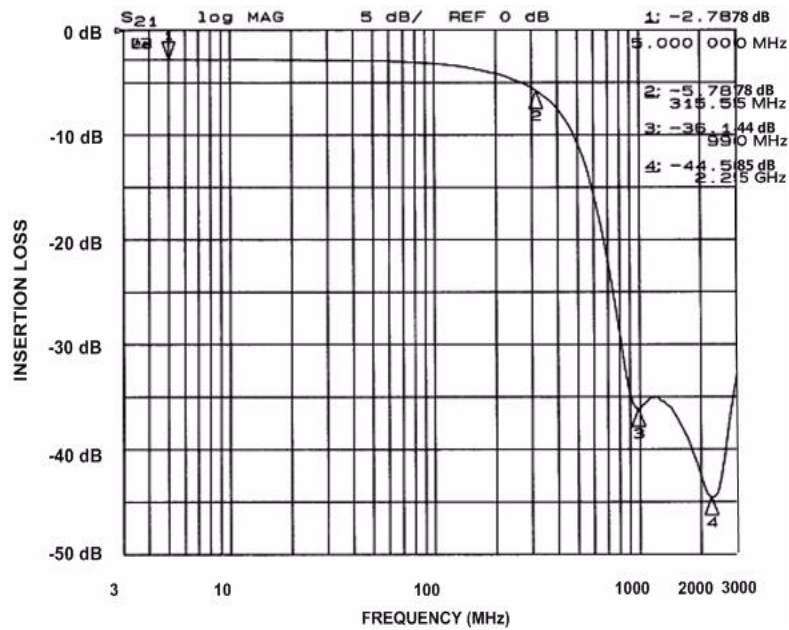

Figure 2. Insertion Loss VS. Frequency (Pins 2 and 15)

Performance Information (cont'd)

Typical Filter Performance (nominal conditions unless specified otherwise, 50Ω Environment)

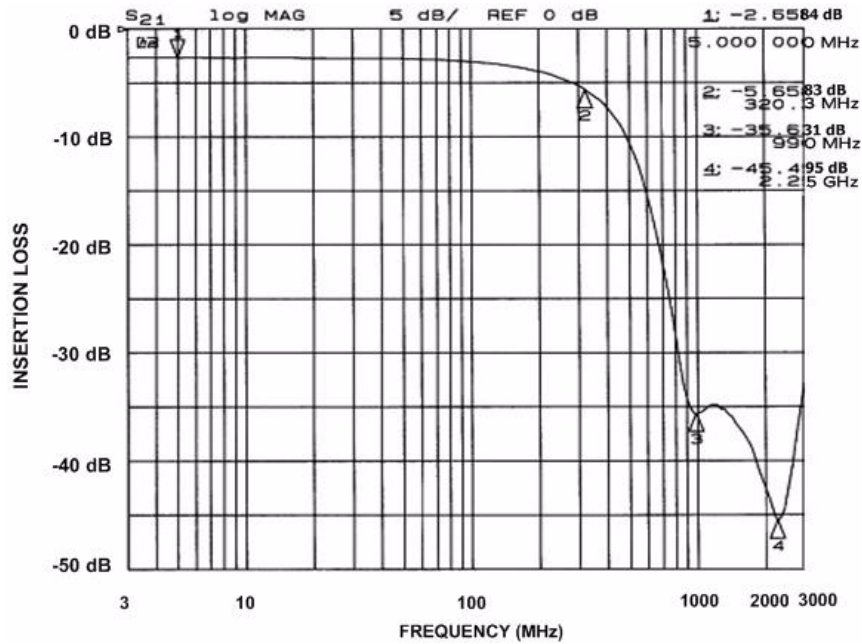

Figure 3. Insertion Loss VS. Frequency (Pins 3 and 14)

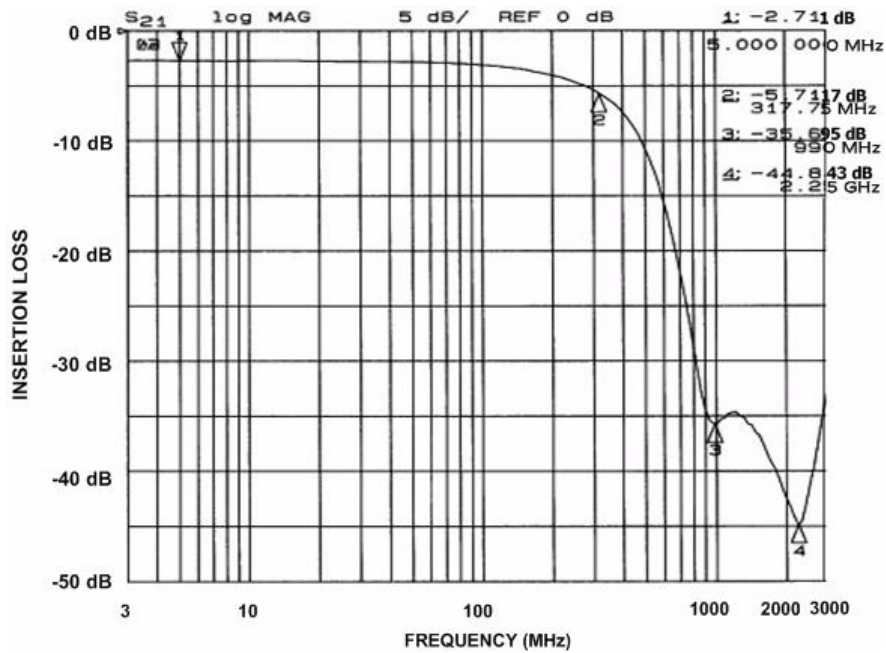

Figure 4. Insertion Loss VS. Frequency (Pins 6 and 11)

Performance Information (cont'd)

Typical Filter Performance (nominal conditions unless specified otherwise, 50Ω Environment)

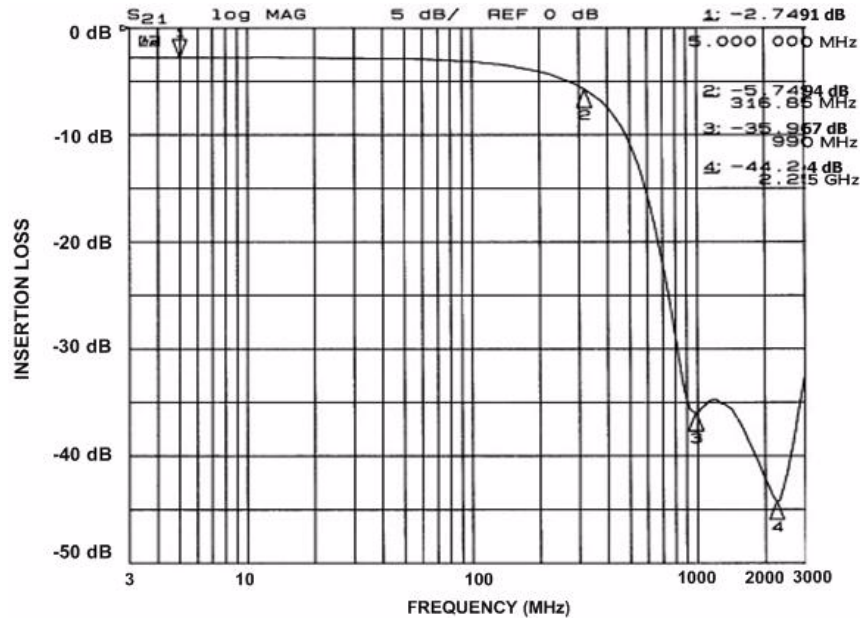

Figure 5. Insertion Loss VS. Frequency (Pins 7 and 10)

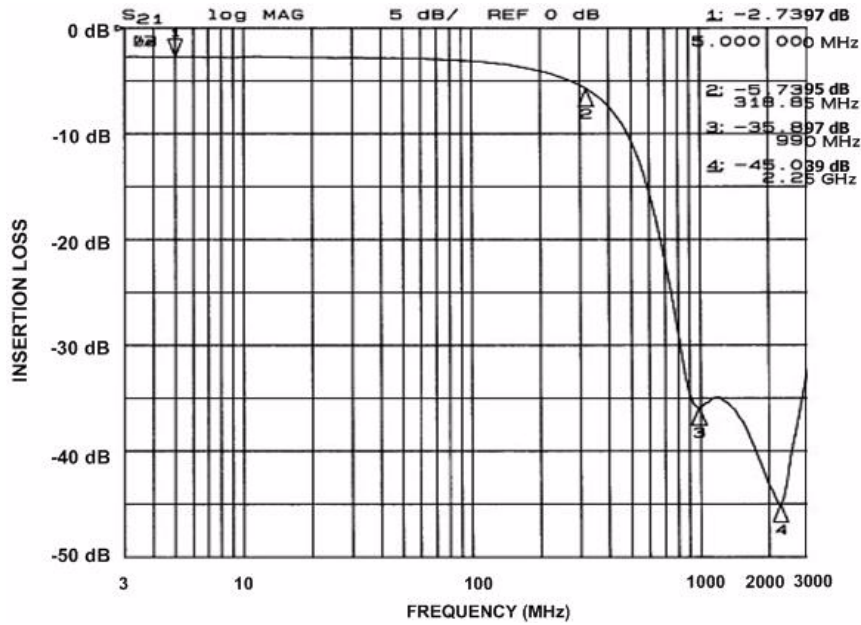

Figure 6. Insertion Loss VS. Frequency (Pins 8 and 9)

Mechanical Details

µDFN-16 Mechanical Specifications, 0.4mm

The 16-lead, 0.4mm pitch µDFN package dimensions are presented below.

PACKAGE DIMENSIONS						
Package	µDFN					
JEDEC No.	MO-229C*					
Leads	16					
Dim.	Millimeters			Inches		
	Min	Nom	Max	Min	Nom	Max
A	0.45	0.50	0.55	0.018	0.020	0.022
A1	0.00	0.02	0.05	0.000	0.001	0.002
A3	0.127 REF			0.005 REF		
b	0.15	0.20	0.25	0.006	0.008	0.010
D	3.20	3.30	3.40	0.126	0.130	0.134
D2	2.70	2.80	2.90	0.106	0.110	0.114
E	1.25	1.35	1.45	0.049	0.053	0.057
E2	0.30	0.40	0.50	0.012	0.016	0.020
e	0.40 BSC			0.016 BSC		
K	0.22 REF			0.009 REF		
L	0.15	0.25	0.35	0.006	0.010	0.014
# per tape and reel	3000 pieces					
Controlling dimension: millimeters						

*This package is compliant with JEDEC standard MO-229C with the exception of the D, D2, E, E2, K and L dimensions as called out in the table above.

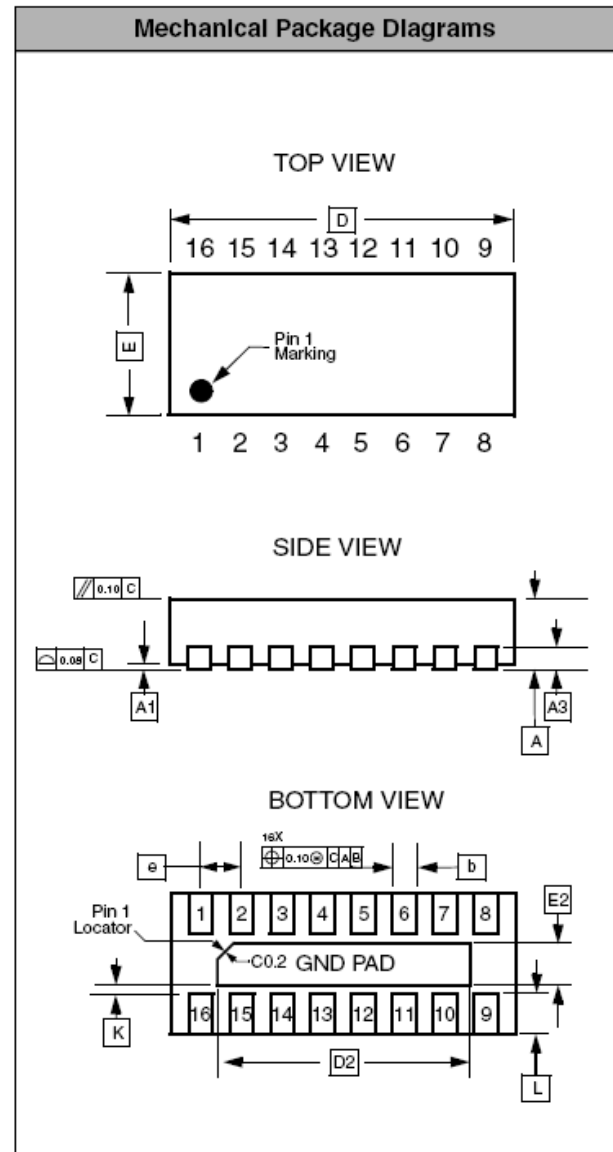



Dimensions for 16-Lead, 0.4mm pitch µDFN package

CM1624

Tape and Reel Specifications

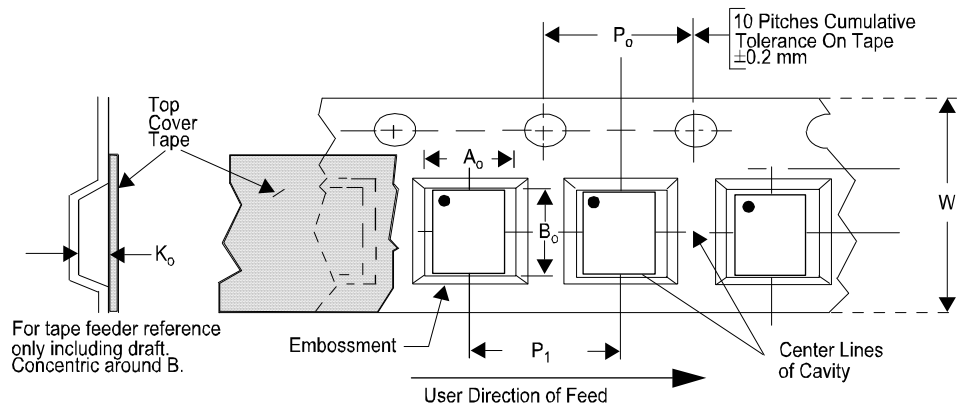
PART NUMBER	PACKAGE SIZE (mm)	POCKET SIZE (mm) $B_0 \times A_0 \times K_0$	TAPE WIDTH W	REEL DIAMETER	QTY PER REEL	P_0	P_1
CM1624 -08DE	3.30 X 1.35 X 0.50	3.50 X 1.55 X 0.70	12mm	178mm (7")	3000	4mm	4mm



ON Semiconductor and  are registered trademarks of Semiconductor Components Industries, LLC (SCILLC). SCILLC reserves the right to make changes without further notice to any products herein. SCILLC makes no warranty, representation or guarantee regarding the suitability of its products for any particular purpose, nor does SCILLC assume any liability arising out of the application or use of any product or circuit, and specifically disclaims any and all liability, including without limitation special, consequential or incidental damages. "Typical" parameters which may be provided in SCILLC data sheets and/or specifications can and do vary in different applications and actual performance may vary over time. All operating parameters, including "Typicals" must be validated for each customer application by customer's technical experts. SCILLC does not convey any license under its patent rights nor the rights of others. SCILLC products are not designed, intended, or authorized for use as components in systems intended for surgical implant into the body, or other applications intended to support or sustain life, or for any other application in which the failure of the SCILLC product could create a situation where personal injury or death may occur. Should Buyer purchase or use SCILLC products for any such unintended or unauthorized application, Buyer shall indemnify and hold SCILLC and its officers, employees, subsidiaries, affiliates, and distributors harmless against all claims, costs, damages, and expenses, and reasonable attorney fees arising out of, directly or indirectly, any claim of personal injury or death associated with such unintended or unauthorized use, even if such claim alleges that SCILLC was negligent regarding the design or manufacture of the part. SCILLC is an Equal Opportunity/Affirmative Action Employer. This literature is subject to all applicable copyright laws and is not for resale in any manner.

PUBLICATION ORDERING INFORMATION

LITERATURE FULFILLMENT:

Literature Distribution Center for ON Semiconductor
P.O. Box 5163, Denver, Colorado 80217 USA
Phone: 303-675-2175 or 800-344-3860 Toll Free USA/Canada
Fax: 303-675-2176 or 800-344-3867 Toll Free USA/Canada
Email: orderlit@onsemi.com

N. American Technical Support: 800-282-9855
Toll Free USA/Canada
Europe, Middle East and Africa Technical Support:
Phone: 421 33 790 2910
Japan Customer Focus Center
Phone: 81-3-5773-3850

ON Semiconductor Website: www.onsemi.com

Order Literature: <http://www.onsemi.com/orderlit>

For additional information, please contact your local
Sales Representative

Компания «Life Electronics» занимается поставками электронных компонентов импортного и отечественного производства от производителей и со складов крупных дистрибьюторов Европы, Америки и Азии.

С конца 2013 года компания активно расширяет линейку поставок компонентов по направлению коаксиальный кабель, кварцевые генераторы и конденсаторы (керамические, пленочные, электролитические), за счёт заключения дистрибьюторских договоров

Мы предлагаем:

- Конкурентоспособные цены и скидки постоянным клиентам.
- Специальные условия для постоянных клиентов.
- Подбор аналогов.
- Поставку компонентов в любых объемах, удовлетворяющих вашим потребностям.
- Приемлемые сроки поставки, возможна ускоренная поставка.
- Доставку товара в любую точку России и стран СНГ.
- Комплексную поставку.
- Работу по проектам и поставку образцов.
- Формирование склада под заказчика.
- Сертификаты соответствия на поставляемую продукцию (по желанию клиента).
- Тестирование поставляемой продукции.
- Поставку компонентов, требующих военную и космическую приемку.
- Входной контроль качества.
- Наличие сертификата ISO.

В составе нашей компании организован Конструкторский отдел, призванный помогать разработчикам, и инженерам.

Конструкторский отдел помогает осуществить:

- Регистрацию проекта у производителя компонентов.
- Техническую поддержку проекта.
- Защиту от снятия компонента с производства.
- Оценку стоимости проекта по компонентам.
- Изготовление тестовой платы монтаж и пусконаладочные работы.



Тел: +7 (812) 336 43 04 (многоканальный)

Email: org@lifeelectronics.ru