

THIS DRAWING IS UNPUBLISHED. RELEASED FOR PUBLICATION 2000
 © COPYRIGHT 2000 ALL RIGHTS RESERVED.

LOC	DIST	REVISIONS					
		P	LTR	DESCRIPTION	DATE	DWN	APVD
IR	-	AA		ECR-10-020218	28DEC2010	PS	RRP
		AA1		ECR-10-026537	08AUG11	KK	HMR
		AA2		ECR-13-013525	29AUG2013	CW	SH
		AA3		REVISE PER ECO-12-008315	11MAY2015	AD	SH

- SEE SHEET 2 FOR MODULAR JACK 6 POS./4 CONTACTS
- FOR APPLICATION INFORMATION SEE SPEC. 114-19019.
- FOR PERFORMANCE REQUIREMENTS SEE SPEC. 108-19064.
- TOLERANCES UNLESS OTHERWISE SPECIFIED: ± 0,15mm.

TRUE POSITIONING WILL NOT BE GUARANTEED USING THIS PACKAGING TYPE.

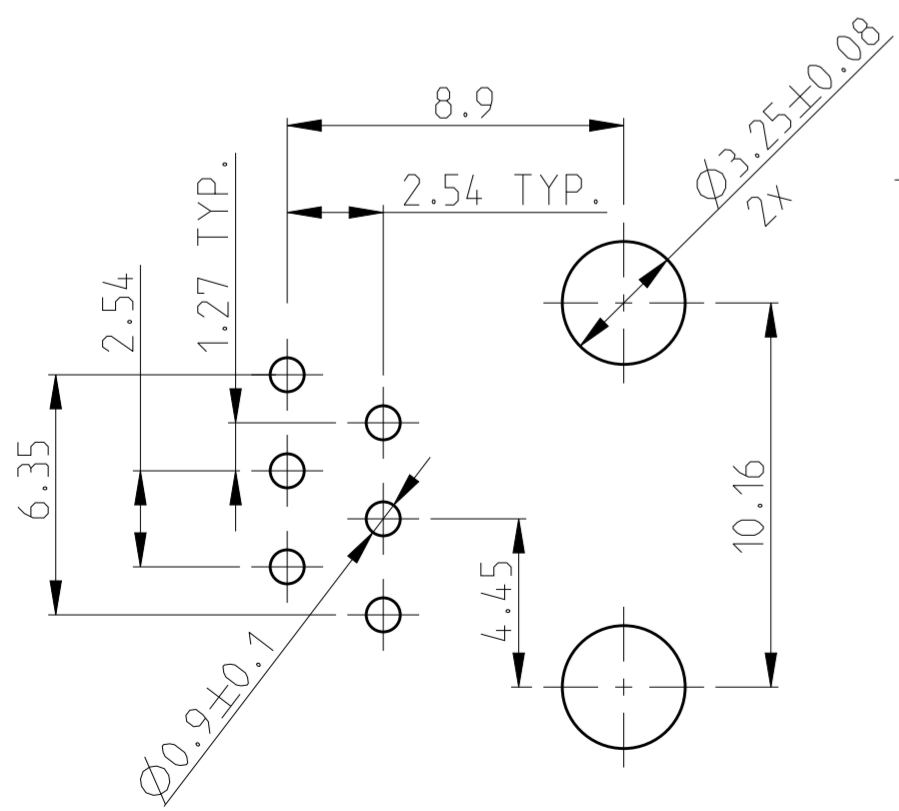
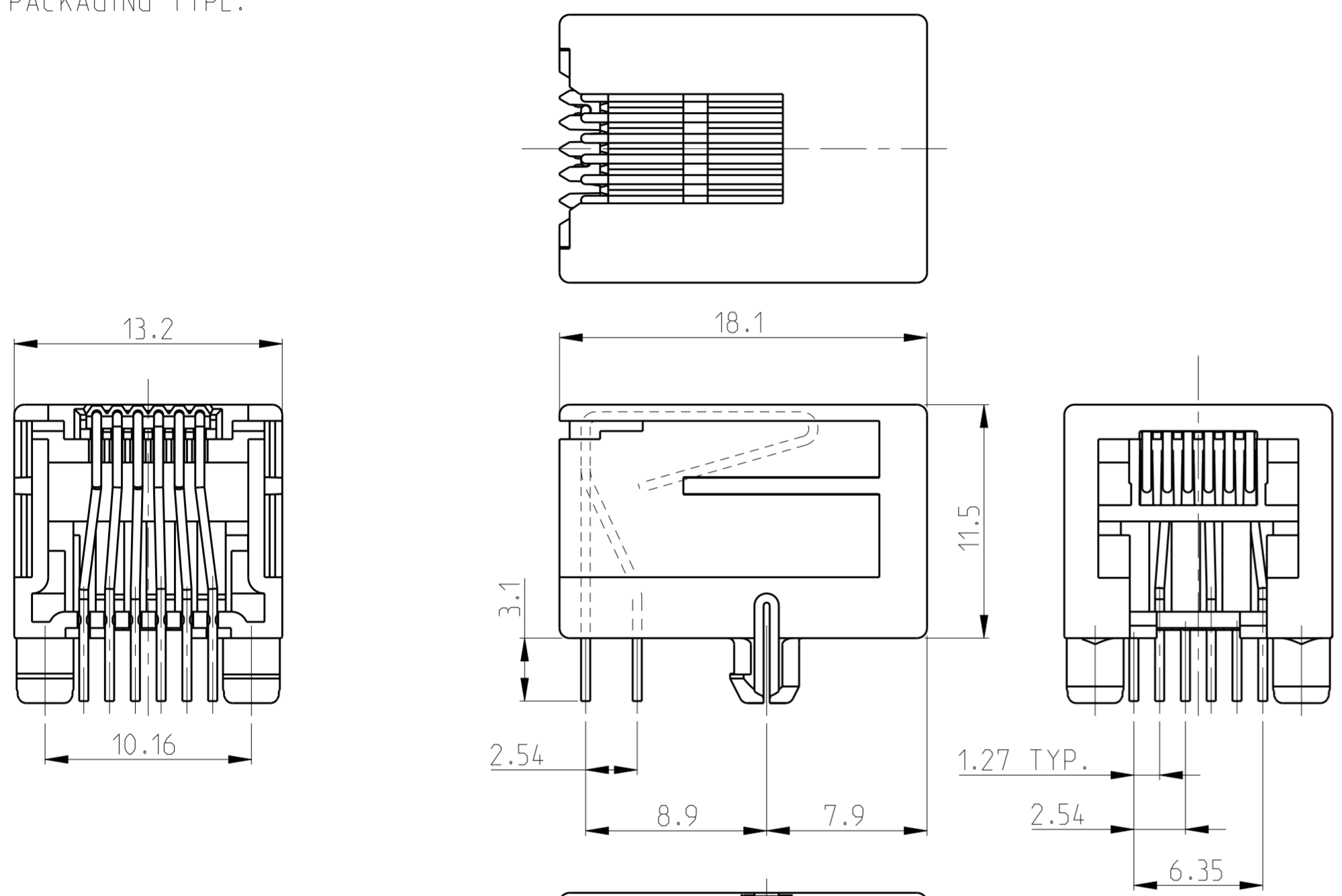
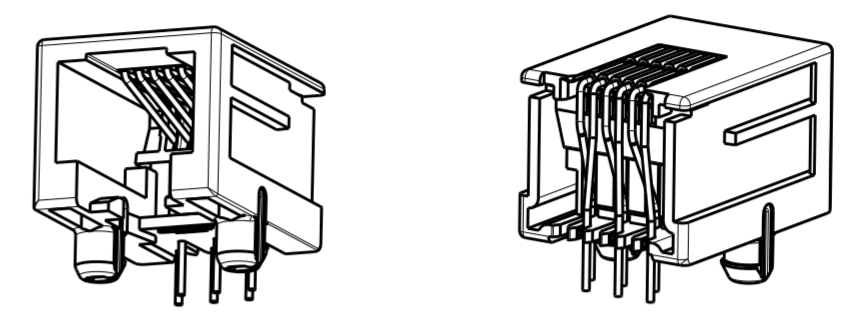

PRINTED CIRCUIT BOARD LAYOUT (6 POS./6 CONTACTS)
 [VIEW SHOWN IS CIRCUIT (NON-COMPONENT) SIDE OF BOARD]
 PRINTED CIRCUIT BOARD THICKNESS: 1,6mm NOMINAL.
 TOLERANCES UNLESS OTHERWISE SPECIFIED: ± 0,05

PACKAGING	REMARKS	FINISH	MATERIAL	P/N
TAPE MOUNTED 800 PCS/REEL	6 POS./ 6 CONTACTS		HOUSING COLOR BLACK	2-215876-3
BULK PACKED 1000 PCS IN A BOX	SUPERSEDED BY 215876-3		HOUSING AND CONTACT INSERT: UL 94-V0	2-215876-1
240 PIECES IN A TRAY	6 POS./ 6 CONTACTS	OVERALL: Ni 1.27 µm MIN. ALL OVER THE CONTACTS	HOUSING PA 4.6 CONTACT INSERT: PCT	OBSOLETE 2-215876-0
BULK PACKED 1000 PCS IN A BOX	SUPERSEDED BY 215876-1	SOLDER ZONE: Sn 2.5 µm MIN. ON THE SOLDER ZONE OF THE CONTACT	HOUSING COLOR BLACK PBT, UL 94 V-0	3-215876-1
240 PIECES IN A TRAY	6 POS./ 6 CONTACTS	MATING ZONE: PLATING CONFIRMS TO PRODUCT REQUIREMENTS AS PER SPECIFICATION 108-19064	CONTACT INSERT: PBT, UL 94 V-0	1-215876-3
108 PCS IN A MULTI-TUBE	SUPERSEDED BY 1-215876-3		CONTACTS: PH-BRONZE	1-215876-1
TAPE MOUNTED 800 PCS/REEL	6 POS./ 6 CONTACTS			215876-1

THIS DRAWING IS A CONTROLLED DOCUMENT.

DWN G.CONSTANT 24 SEP 96	TE Connectivity MODULAR JACK, SIDE ENTRY, 6/6 FOR PRINTED CIRCUIT BOARD
CHK G.CONSTANT 24 SEP 96	
APVD R.SMEETS	NAME
PRODUCT SPEC 108-19064	SIZE
APPLICATION SPEC 114-19019	CAGE CODE
WEIGHT	DRAWING NO C-215876
MATERIAL	RESTRICTED TO
	SCALE 4:1
	SHEET 1 OF 4
	REV AA3

CUSTOMER DRAWING

THIS DRAWING IS UNPUBLISHED. RELEASED FOR PUBLICATION 2000
 © COPYRIGHT 2000 ALL RIGHTS RESERVED.

LOC		DIST		REVISIONS			
P	LTR	DESCRIPTION	DATE	DWN	APVD		
-	-	SEE SHEET 1	-	-	-		

- 1 SEE SHEET 1 FOR MODULAR JACK 6 POS./6 CONTACTS.
- 2 FOR APPLICATION INFORMATION SEE SPEC. 114-19019.
- 3 FOR PERFORMANCE REQUIREMENT SEE SPEC. 108-19064.
- 4 TOLERANCES UNLESS OTHERWISE SPECIFIED: ±0.15.

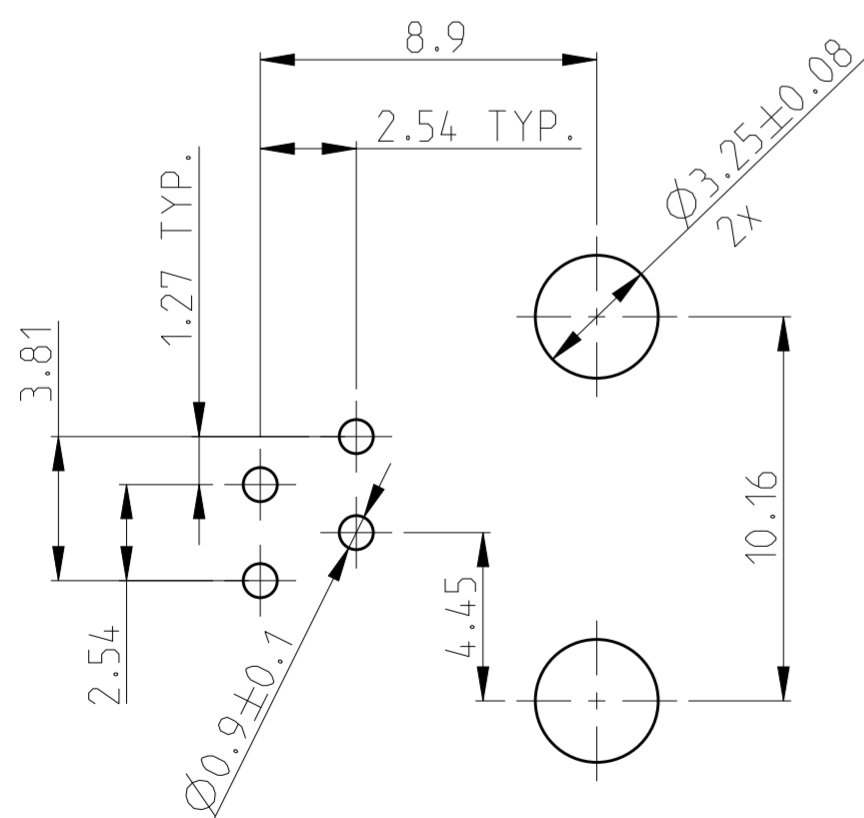
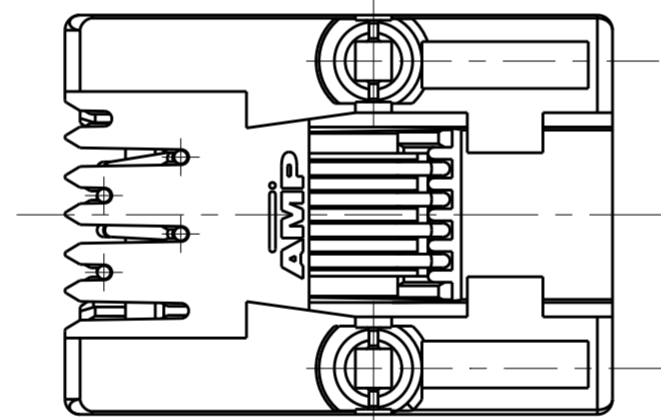
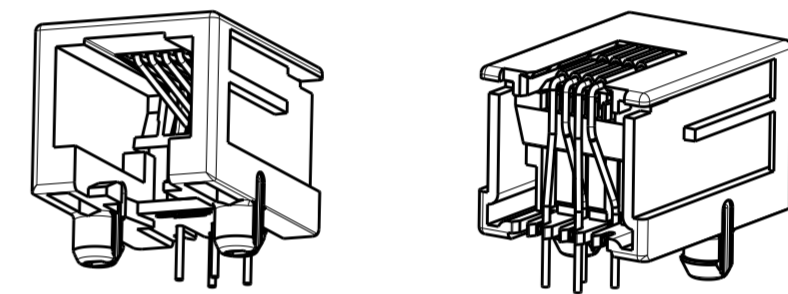
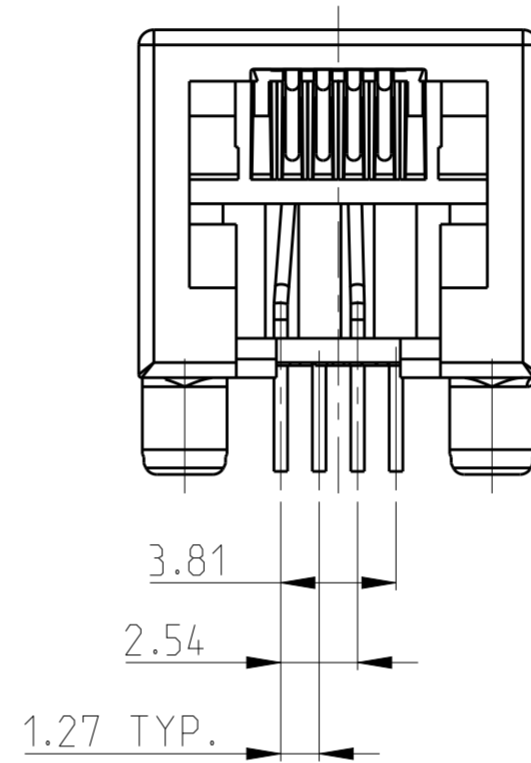
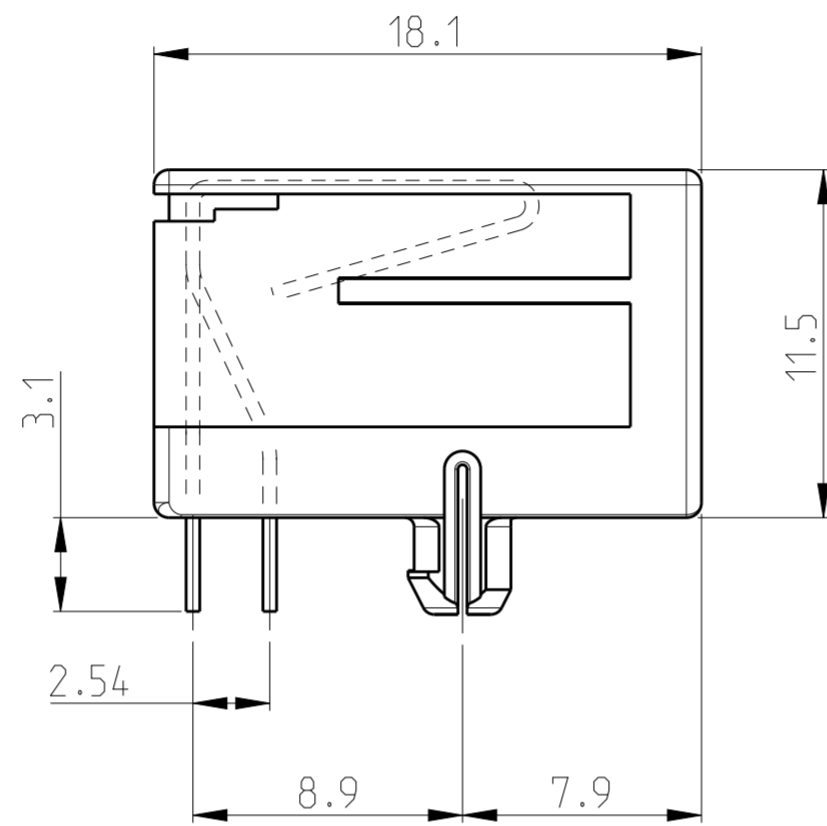
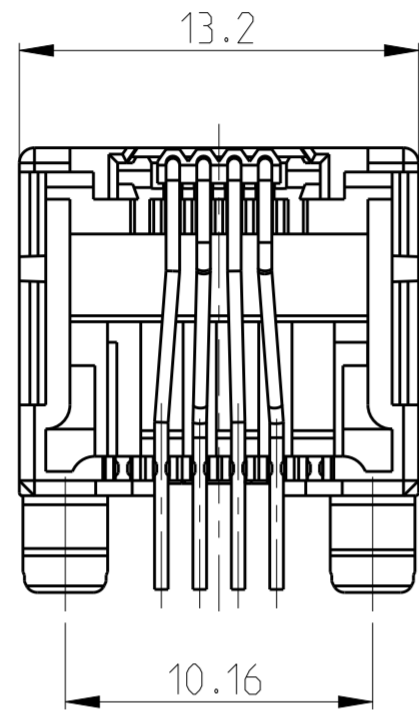

PRINTED CIRCUIT BOARD LAYOUT (6 POS./4 CONTACT)

[VIEW SHOWN IS CIRCUIT (NON-COMPONENT) SIDE OF BOARD]
 PRINTED CIRCUIT BOARD THICKNESS: 1.6mm NOMINAL.
 TOLERANCES UNLESS OTHERWISE SPECIFIED: ± 0.05.

240 PIECES IN A TRAY	6 POS./ 4 CONTACTS	SAME AS 215876-2	SAME AS 215876-2	3-215876-2
TAPE MOUNTED 800 PCS/REEL	6 POS./ 4 CONTACTS	OVERALL: Ni 1.27 µm MIN. ALL OVER THE CONTACTS SOLDER ZONE: Sn 2.5 µm MIN. ON THE SOLDER ZONE OF THE CONTACT MATING ZONE: PLATING CONFIRMS TO PRODUCT REQUIREMENTS AS PER SPECIFICATION 108-19064	HOUSING COLOR BLACK: PBT, UL 94 V-0 CONTACT INSERT: PBT, UL 94 V-0 CONTACTS: Ph-BRONZE	215876-2
PACKAGING	REMARKS	FINISH	MATERIAL	P/N
	SUPERSEDED BY 215876-2			1-215876-2

THIS DRAWING IS A CONTROLLED DOCUMENT.

DIMENSIONS: mm	TOLERANCES UNLESS OTHERWISE SPECIFIED:	DWN G.CONSTANT 24 SEP 96	CHK G.CONSTANT 24 SEP 96	APVD R.SMEETS	NAME
0 PLC ±	1 PLC ±	PRODUCT SPEC	108-19064	114-19019	MODULAR JACK, SIDE ENTRY, 6/4 FOR PRINTED CIRCUIT BOARD
2 PLC ±	3 PLC ±	APPLICATION SPEC	114-19019	WEIGHT	SIZE A2
4 PLC ±	ANGLES ±	CUSTOMER DRAWING	SCALE 4:1	SHEET 2 OF 4	RESTRICTED TO
MATERIAL	FINISH				REV AA3

STE TE Connectivity

THIS DRAWING IS UNPUBLISHED. RELEASED FOR PUBLICATION 2000
 © COPYRIGHT 2000 ALL RIGHTS RESERVED.

LOC	DIST	REVISIONS			
P	LTR	DESCRIPTION	DATE	DWN	APVD
IR	-	SEE SHEET 1	-	-	-
-	-	-	-	-	-

- SEE SHEET 4 FOR MODULAR JACK 6 POS./4 CONTACTS WITH CONTACT COVER.
- FOR APPLICATION INFORMATION SEE SPEC. 114-19019.
- FOR PERFORMANCE REQUIREMENTS SEE SPEC. 108-19064.
- TOLERANCES UNLESS OTHERWISE SPECIFIED: $\pm 0,15\text{mm}$.

TRUE POSITIONING WILL NOT BE GUARANTEED USING THIS PACKAGING TYPE.

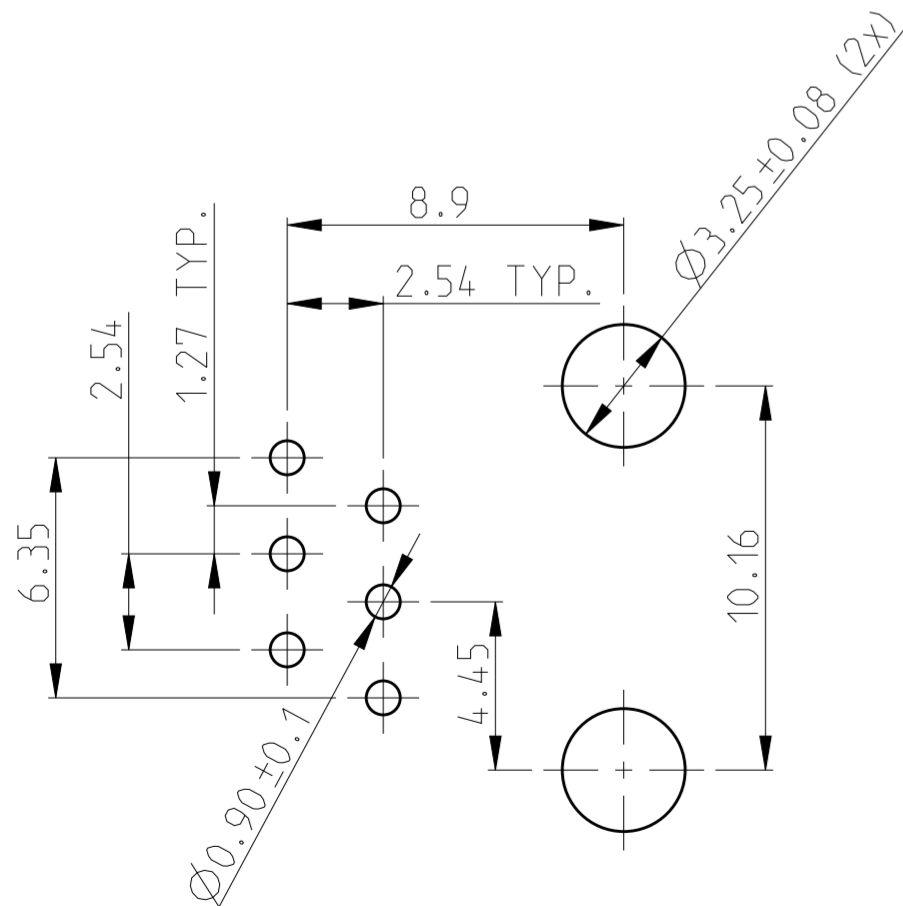
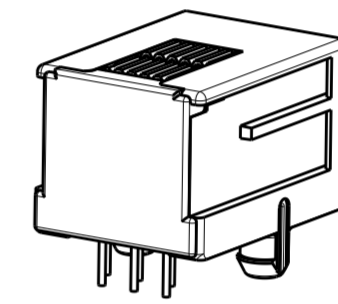
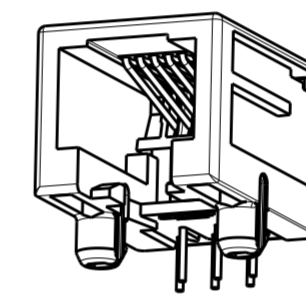
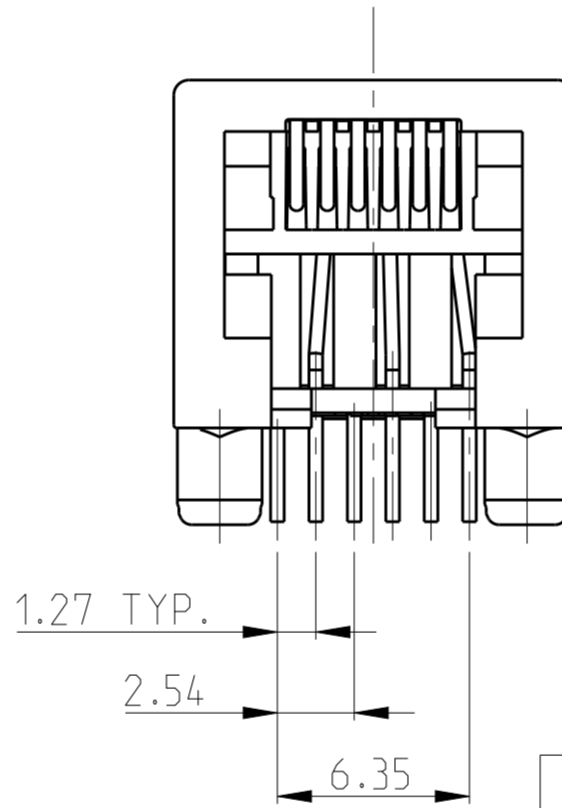
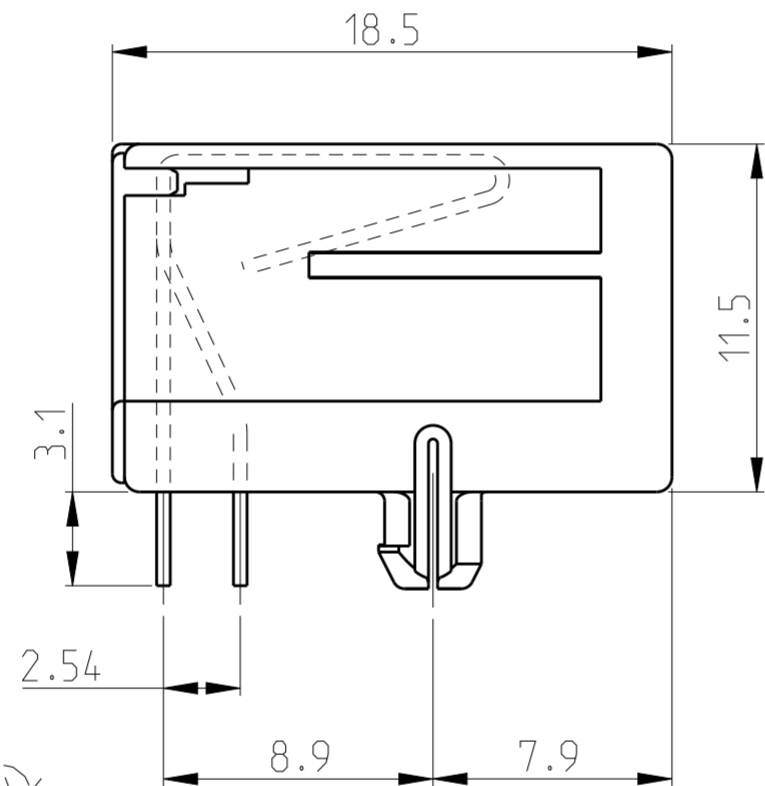
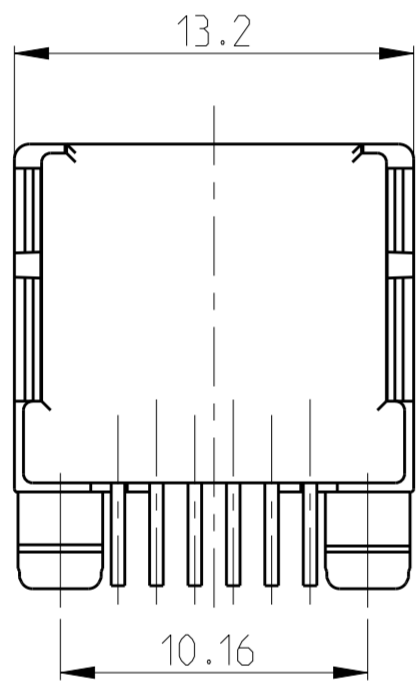
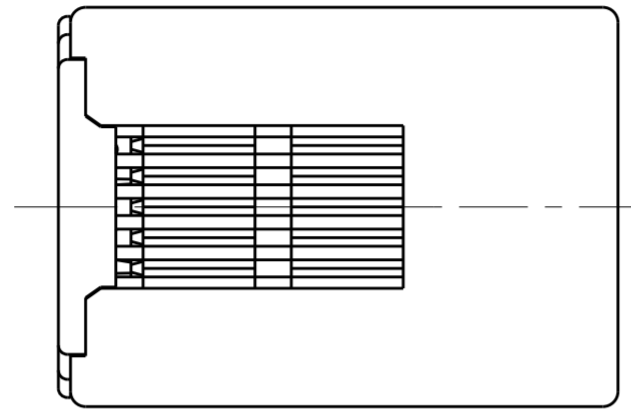

PRINTED CIRCUIT BOARD LAYOUT (6 POS./6 CONTACTS)

[VIEW SHOWN IS CIRCUIT (NON-COMPONENT) SIDE OF BOARD]
 PRINTED CIRCUIT BOARD THICKNESS: 1,6mm NOMINAL.
 TOLERANCES UNLESS OTHERWISE SPECIFIED: $\pm 0,05$

OBSOLETE

OBSOLETE

OBSOLETE

PACKAGING	REMARKS	FINISH	MATERIAL	P/N
BULK PACKED 1000 PCS IN A BOX			HOUSING COLOR BLACK PBT, UL94 V-0	5-215876-4
240 PIECES IN A TRAY	6 POS./ 6 CONTACTS	IN CONTACT AREA: 1,2 μm MIN. SEL. GOLD OVER 1,2 μm MIN. NICKEL	CONTACT INSERT: PBT, UL94 V-0	5-215876-3
TAPE MOUNTED 800 PCS/REEL		SOLDER TINES: 2,5 μm MIN. TIN OVER 1,2 μm MIN. NICKEL	CONTACT COVER: PBT, UL94 V-0	5-215876-1
			CONTACTS: PH-BRONZE	

THIS DRAWING IS A CONTROLLED DOCUMENT.

DIMENSIONS: mm	TOLERANCES UNLESS OTHERWISE SPECIFIED:	DWN P.Willems 10-OCT-05	TE Connectivity
	0 PLC \pm	CHK P.Willems 10-OCT-05	
	1 PLC \pm	APVD J.Broeksteeg 10-OCT-05	
	2 PLC \pm	PRODUCT SPEC 108-19064	
	3 PLC \pm	APPLICATION SPEC 114-19019	NAME MODULAR JACK, SIDE ENTRY, 6/6 FOR PRINTED CIRCUIT BOARD WITH CONTACT COVER
	4 PLC \pm	WEIGHT -	SIZE A2
MATERIAL -	FINISH -	CUSTOMER DRAWING	SCALE 4:1 SHEET 3 OF 4 REV AA3

THIS DRAWING IS UNPUBLISHED. RELEASED FOR PUBLICATION 2000
 © COPYRIGHT 2000 ALL RIGHTS RESERVED.

LOC	DIST	REVISIONS			
P	LTR	DESCRIPTION	DATE	DWN	APVD
-	-	SEE SHEET 1	-	-	-

- 1 SEE SHEET 3 FOR MODULAR JACK 6 POS./6 CONTACTS WITH CONTACT COVER.
- 2 FOR APPLICATION INFORMATION SEE SPEC. 114-19019.
- 3 FOR PERFORMANCE REQUIREMENT SEE SPEC. 108-19064.
- 4 TOLERANCES UNLESS OTHERWISE SPECIFIED: $\pm 0,15$.

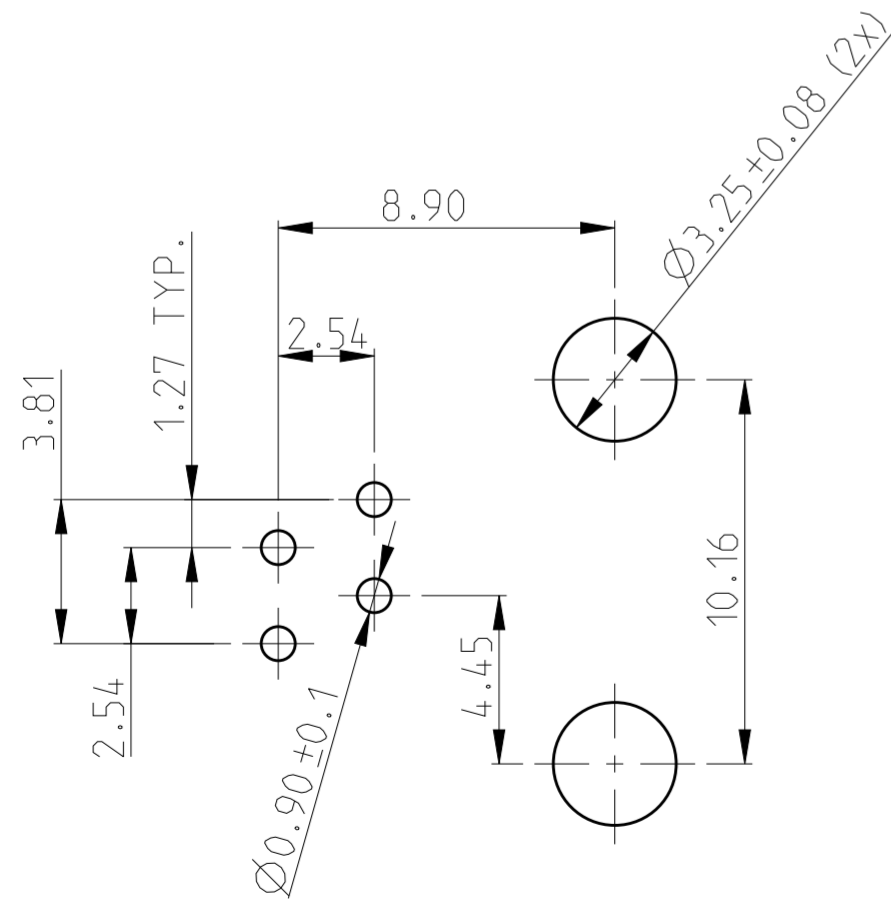
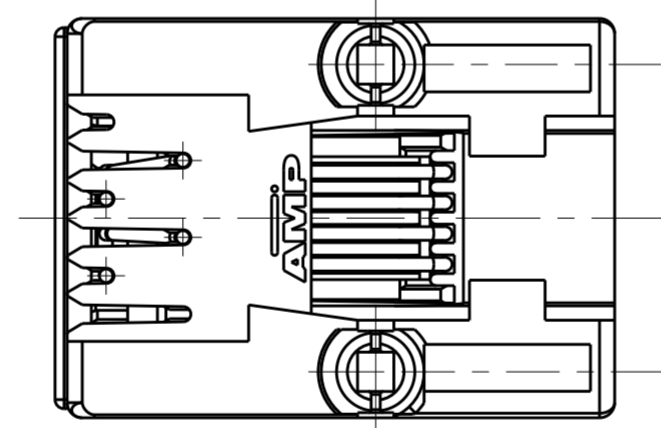
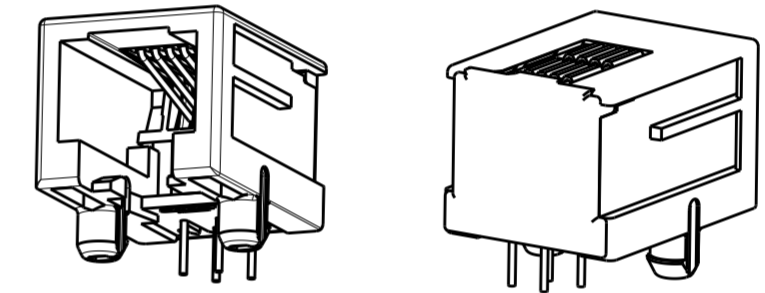
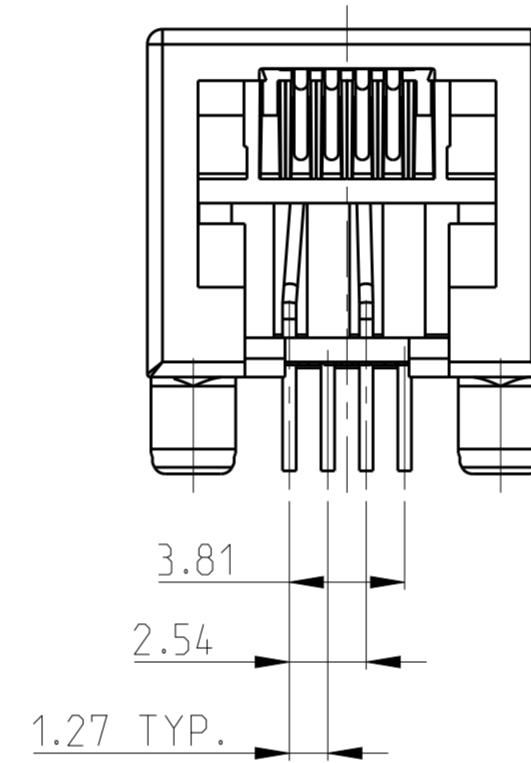
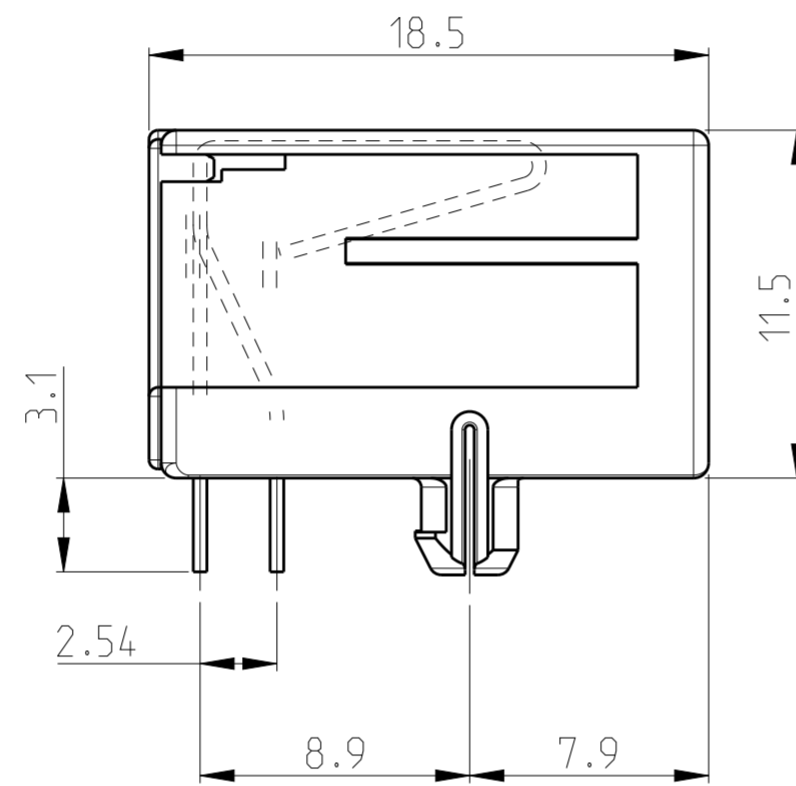
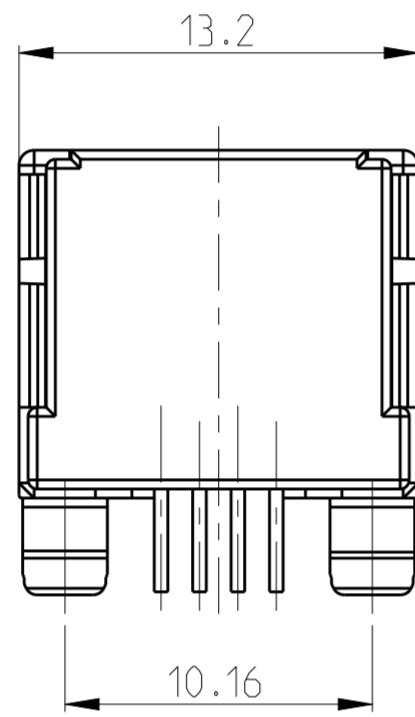

PRINTED CIRCUIT BOARD LAYOUT (6 POS./4 CONTACT)

[VIEW SHOWN IS CIRCUIT (NON-COMPONENT) SIDE OF BOARD]
 PRINTED CIRCUIT BOARD THICKNESS: 1,6mm NOMINAL.
 TOLERANCES UNLESS OTHERWISE SPECIFIED: $\pm 0,05$.

OBSOLETE

TAPE MOUNTED 800 PCS/REEL	6 POS./ 4 CONTACTS	IN CONTACT AREA: 1,2 μ m MIN. SEL. GOLD OVER 1,2 μ m MIN. NICKEL	HOUSING COLOR BLACK PBT, UL94 V-0	5-215876-2
		SOLDER TINES: 2,5 μ m MIN. TIN OVER 1,2 μ m MIN. NICKEL	CONTACT INSERT: PBT, UL94 V-0	
PACKAGING	REMARKS	FINISH	MATERIAL	P/N
			CONTACT COVER: PBT, UL94 V-0	
			CONTACTS: PH-BRONZE	

THIS DRAWING IS A CONTROLLED DOCUMENT.

DWN P.Willems 10-OCT-05	TE Connectivity MODULAR JACK, SIDE ENTRY, 6/4 FOR PRINTED CIRCUIT BOARD WITH CONTACT COVER
CHK P.Willems 10-OCT-05	
APVD J.Broeksteeg 10-OCT-05	
PRODUCT SPEC 108-19064	
APPLICATION SPEC 114-19019	NAME
WEIGHT	SIZE A2
CUSTOMER DRAWING	CAGE CODE C-215876
	DRAWING NO. C-215876
	RESTRICTED TO
	SCALE 4:1
	SHEET 4 OF 4
	REV AA3

Компания «Life Electronics» занимается поставками электронных компонентов импортного и отечественного производства от производителей и со складов крупных дистрибьюторов Европы, Америки и Азии.

С конца 2013 года компания активно расширяет линейку поставок компонентов по направлению коаксиальный кабель, кварцевые генераторы и конденсаторы (керамические, пленочные, электролитические), за счёт заключения дистрибьюторских договоров

Мы предлагаем:

- Конкурентоспособные цены и скидки постоянным клиентам.
- Специальные условия для постоянных клиентов.
- Подбор аналогов.
- Поставку компонентов в любых объемах, удовлетворяющих вашим потребностям.
- Приемлемые сроки поставки, возможна ускоренная поставка.
- Доставку товара в любую точку России и стран СНГ.
- Комплексную поставку.
- Работу по проектам и поставку образцов.
- Формирование склада под заказчика.
- Сертификаты соответствия на поставляемую продукцию (по желанию клиента).
- Тестирование поставляемой продукции.
- Поставку компонентов, требующих военную и космическую приемку.
- Входной контроль качества.
- Наличие сертификата ISO.

В составе нашей компании организован Конструкторский отдел, призванный помогать разработчикам, и инженерам.

Конструкторский отдел помогает осуществить:

- Регистрацию проекта у производителя компонентов.
- Техническую поддержку проекта.
- Защиту от снятия компонента с производства.
- Оценку стоимости проекта по компонентам.
- Изготовление тестовой платы монтаж и пусконаладочные работы.



Тел: +7 (812) 336 43 04 (многоканальный)
Email: org@lifeelectronics.ru