

General Description

The 885026 is a high-performance Bulk Acoustic Wave (BAW) filter designed to meet the strict LTE rejection requirements for use in B38.

885026 is specifically designed to meet the high-performance expectations of insertion loss and rejection for LTE transmit systems under all operating conditions.

The 885026 uses common module packaging techniques to achieve the industry standard 1.4 x 1.2 x 0.46 mm footprint.

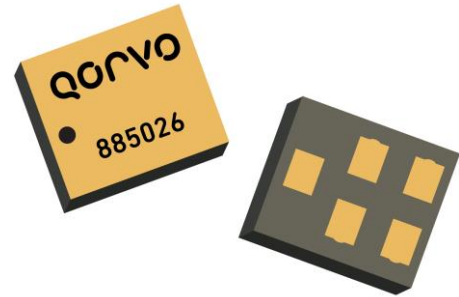

Functional Block Diagram

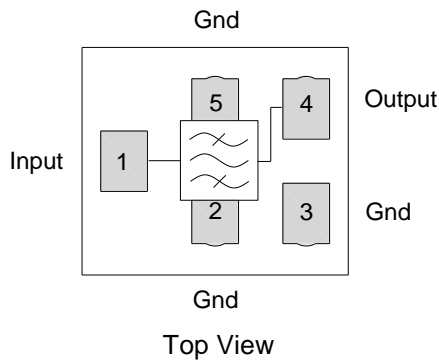

Pin Configuration – Single Ended

Pin No.	Label
1	Input
4	Output
2,3,5	Ground

Product Features

- Highly selective BAW filter achieving low insertion loss over full bandwidth and operating conditions
- Rejection in WLAN band of 40dB minimum
- Rejection in Band 7 Rx band of 10dB minimum
- Performance -20 to +90 °C
- Ceramic chip-scale Package (CSP)
- Small Size: 1.4 x 1.2 x 0.46 mm
- Hermetically Sealed
- RoHS compliant, Pb-free

Applications

- For Band 38 TD-LTE applications
- B7/B38/B40 LTE handset, data cards, mobile routers

Ordering Information

Part No.	Description
885026	Packaged part
885026-EVB	Evaluation board

Standard T/R size = 10,000 units/reel

Absolute Maximum Ratings

Parameter	Rating
Storage Temperature	-40 to +125 °C
Operable Temperature	-40 to +90 °C
RF Input Power, CW, 50Ω, T=25 °C	+29dBm

Note: Operation of this device outside the parameter ranges given may cause permanent damage.

MTTF

Parameter	Min
RF Input Power +29dBm, CW, in band at 55 °C	10,000 hrs.

Electrical Specifications ⁽¹⁾⁽²⁾

Conditions unless otherwise noted: ⁽³⁾ Device Temperature = 0°C to +70°C.

Parameter ⁽²⁾	Conditions	Min	Typ	Max	Units
Center Frequency		-	2595		dB
Insertion Loss	2570 – 2620 MHz	-	1.5	2.5	dB
	2570 – 2620 MHz		1.5	2.1 ⁽⁴⁾	dB
Attenuation ⁽⁵⁾	10 – 1574 MHz	30	33	-	dB
	1559 – 1606 MHz	33	34	-	
	1607 – 2300 MHz	32	34	-	
	2400 – 2500 MHz	39	41	-	
	2505 – 2535 MHz ⁽⁶⁾	20	37	-	
	2645 – 2670 MHz	10	16	-	
	5150 – 5230 MHz	30	39	-	
7725 – 7845 MHz	25	32	-		
Input VSWR	2570 – 2620 MHz	-	1.6 :1	2.0:1	-
Output VSWR	2570 – 2620 MHz	-	1.6 :1	2.0:1	-
Source/Load Impedance ⁽⁷⁾	Single-ended	-	50	-	Ω

Notes:

1. All specifications are based on the test circuit shown on page 3
2. Electrical margin has been built into the design to account for the variations due to manufacturing tolerances.
3. In production, devices will be tested at room temperature to a guard-banded specification to ensure electrical compliance over temperature
4. At 25 °C only
5. Measurement made relative to zero dB
6. Specified from 0°C to +55°C only.
7. This is the optimum impedance in order to achieve the performance shown.

Evaluation Board

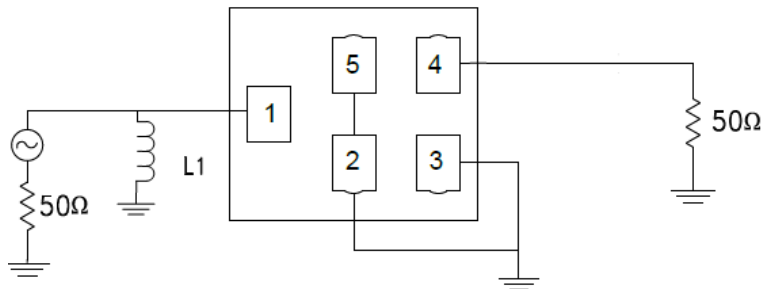
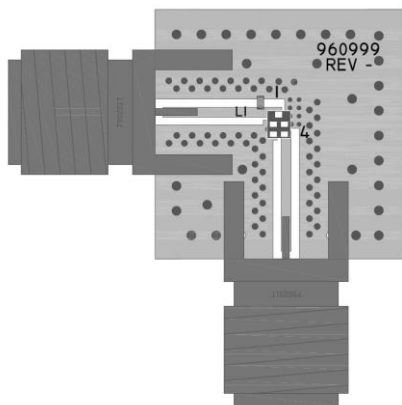

Notes:

1. Matching component values shown are for the specified TriQuint evaluation board. Value adjustment may be required in end user product circuits depending on component manufacturer and PCB material.
2. PCB: .500 x .500 x .062; Construction: ½ oz. Cu Top Layer; TLY-5A (.0075) ½ oz. Cu Middle Layer, FR4; ½ oz. Cu Bottom Layer. (dimensions are in inches)

Bill of Material

Reference Des.	Value	Description	Manuf.	Part Number
L1	20 nH	0201 chip inductors ±3%	MuRata	LQP03TN20NH02
SMA	N/A	SMA connector	Radiall USA	9602-1111-018
PCB	N/A	3-layer	Multiple	960999

PCB Mounting Pattern

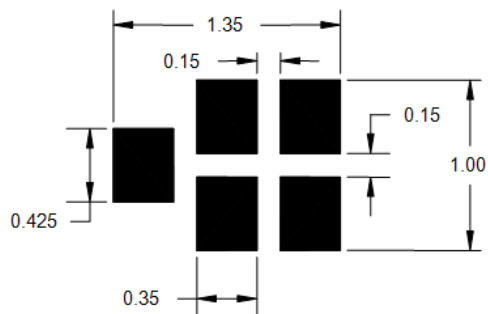

Notes:

1. All dimensions are in millimeters. Angles are in degrees.
2. This drawing specifies the mounting pattern used on the Qorvo evaluation board for this product. Some modification may be necessary to suit end user assembly materials and processes.

Performance Plots

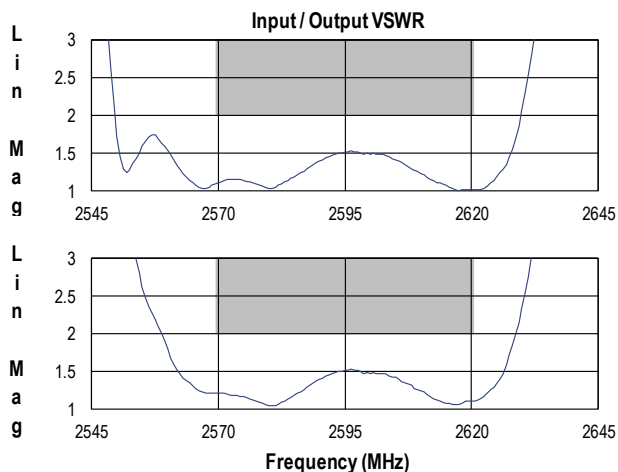
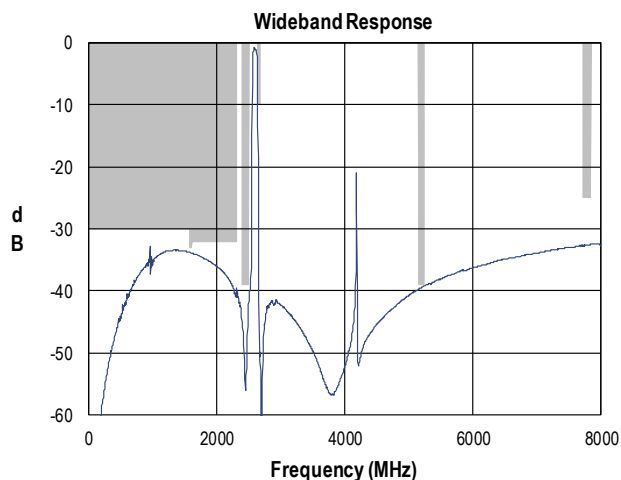
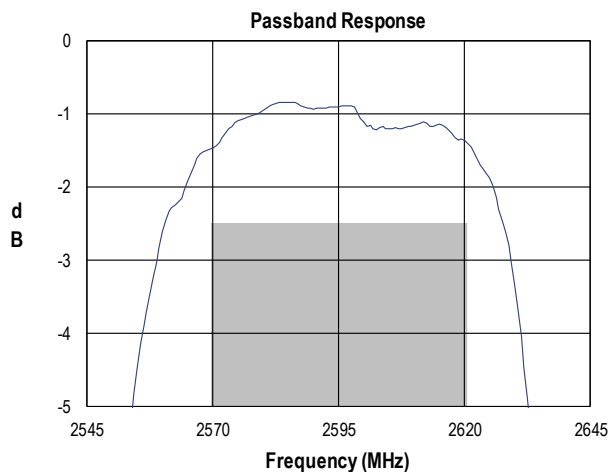
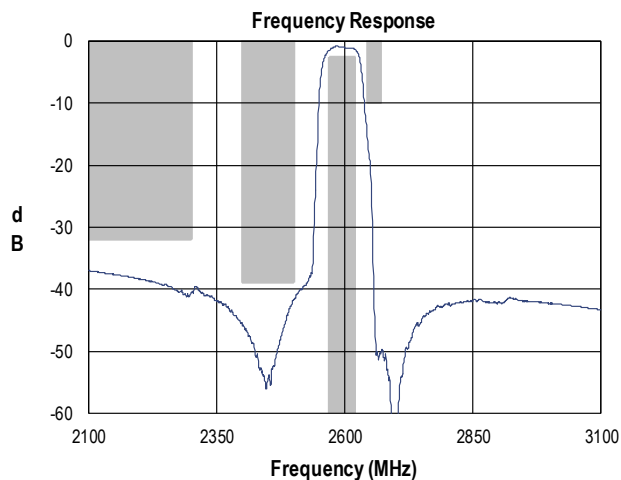

Input Smith Chart

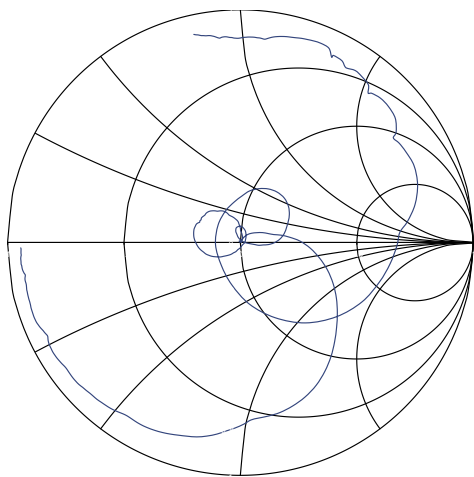

Output Smith Chart

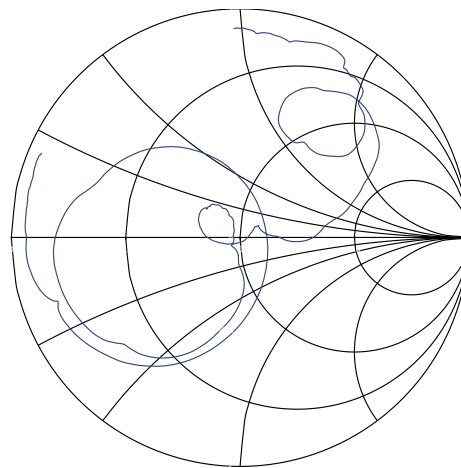

Package Information, Marking and Dimensions

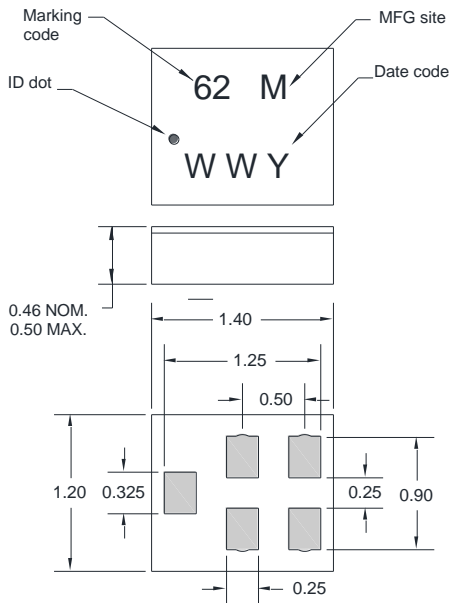

Package Style: CSP-5CT
 Dimensions: 1.4 x 1.2 x 0.46 mm

Body: Al_2O_3 ceramic
 Lid: Kovar or Alloy 42, Au over Ni plated
 Terminations: Au plating 0.5 - 1.0 μm , over a 2-6 μm Ni plating

The date code consists of: WW = 2 digit week,
 Y = last digit of year, M = manufacturing site code

Notes:

1. All dimensions shown are typical in millimeters.
2. Unless otherwise specified all tolerances are $\pm 0.05\text{mm}$ except length and width that are specified as $\pm 0.1\text{mm}$.
3. An asterisk (*) in front of the marking code indicates prototype.

Tape and Reel information

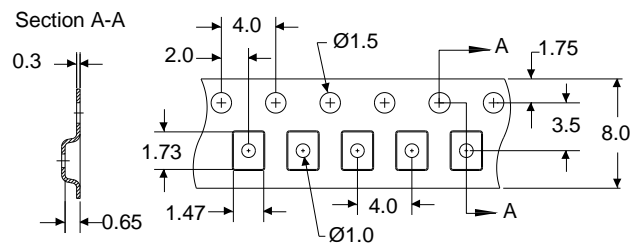
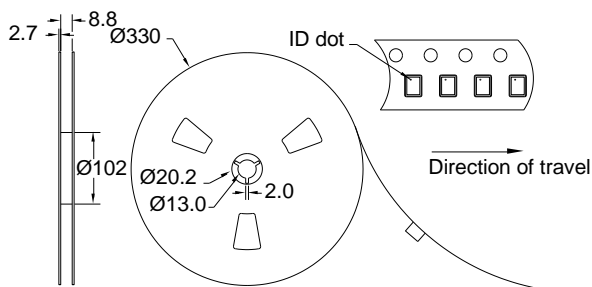

Standard T/R size=10,000 units/reel.
 All dimensions are in millimeters.

Handling Precautions

Parameter	Rating	Standard
ESD – Human Body Model (HBM)	Class 1C	ESDA / JEDEC JS-001
ESD – Charge Device Model (CDM)	Class C1	ESDA/JEDEC JS-002
MSL – Moisture Sensitivity Level	N/A *	Hermetic package

*Hermetically sealed ceramic package



Caution!
ESD-Sensitive Device

Solderability

Compatible with both lead-free (260°C max. reflow temp.) and tin/lead (245°C max. reflow temp.) soldering processes.
Solder profiles available upon request.

RoHS Compliance

This part is compliant with 2011/65/EU RoHS directive (Restrictions on the Use of Certain Hazardous Substances in Electrical and Electronic Equipment) as amended by Directive 2015/863/EU. This product also has the following attributes:

- Lead Free
- Halogen Free (Chlorine, Bromine)
- Antimony Free
- TBBP-A (C₁₅H₁₂Br₄O₂) Free
- PFOS Free
- SVHC Free



Contact Information

For the latest specifications, additional product information, worldwide sales and distribution locations:

Web: www.qorvo.com
Tel: 1-844-890-8163
Email: customer.support@qorvo.com

Important Notice

The information contained herein is believed to be reliable; however, Qorvo makes no warranties regarding the information contained herein and assumes no responsibility or liability whatsoever for the use of the information contained herein. All information contained herein is subject to change without notice. Customers should obtain and verify the latest relevant information before placing orders for Qorvo products. The information contained herein or any use of such information does not grant, explicitly or implicitly, to any party any patent rights, licenses, or any other intellectual property rights, whether with regard to such information itself or anything described by such information. **THIS INFORMATION DOES NOT CONSTITUTE A WARRANTY WITH RESPECT TO THE PRODUCTS DESCRIBED HEREIN, AND QORVO HEREBY DISCLAIMS ANY AND ALL WARRANTIES WITH RESPECT TO SUCH PRODUCTS WHETHER EXPRESS OR IMPLIED BY LAW, COURSE OF DEALING, COURSE OF PERFORMANCE, USAGE OF TRADE OR OTHERWISE, INCLUDING THE IMPLIED WARRANTIES OF MERCHANTABILITY AND FITNESS FOR A PARTICULAR PURPOSE.**

Without limiting the generality of the foregoing, Qorvo products are not warranted or authorized for use as critical components in medical, life-saving, or life-sustaining applications, or other applications where a failure would reasonably be expected to cause severe personal injury or death.

Copyright 2019 © Qorvo, Inc. | Qorvo is a registered trademark of Qorvo, Inc.

Компания «Life Electronics» занимается поставками электронных компонентов импортного и отечественного производства от производителей и со складов крупных дистрибьюторов Европы, Америки и Азии.

С конца 2013 года компания активно расширяет линейку поставок компонентов по направлению коаксиальный кабель, кварцевые генераторы и конденсаторы (керамические, пленочные, электролитические), за счёт заключения дистрибьюторских договоров

Мы предлагаем:

- Конкуренспособные цены и скидки постоянным клиентам.
- Специальные условия для постоянных клиентов.
- Подбор аналогов.
- Поставку компонентов в любых объемах, удовлетворяющих вашим потребностям.
- Приемлемые сроки поставки, возможна ускоренная поставка.
- Доставку товара в любую точку России и стран СНГ.
- Комплексную поставку.
- Работу по проектам и поставку образцов.
- Формирование склада под заказчика.
- Сертификаты соответствия на поставляемую продукцию (по желанию клиента).
- Тестирование поставляемой продукции.
- Поставку компонентов, требующих военную и космическую приемку.
- Входной контроль качества.
- Наличие сертификата ISO.

В составе нашей компании организован Конструкторский отдел, призванный помогать разработчикам, и инженерам.

Конструкторский отдел помогает осуществить:

- Регистрацию проекта у производителя компонентов.
- Техническую поддержку проекта.
- Защиту от снятия компонента с производства.
- Оценку стоимости проекта по компонентам.
- Изготовление тестовой платы монтаж и пусконаладочные работы.



Тел: +7 (812) 336 43 04 (многоканальный)
Email: org@lifeelectronics.ru